



Title	Dynamics of Tractor-implement Combinations on Slopes (Part) : State-of-the-art Review
Author(s)	Yisa, Mohammed G.; TERAO, Hideo
Citation	Journal of the Faculty of Agriculture, Hokkaido University, 66(2), 240-262
Issue Date	1995-03
Doc URL	http://hdl.handle.net/2115/13138
Type	bulletin (article)
File Information	66(2)_p240-262.pdf



[Instructions for use](#)

Dynamics of Tractor-implement Combinations on Slopes (Part I)

—State-of-the-art Review—

Mohammed G. YISA and Hideo TERAO

Agricultural Vehicle System Engineering, Faculty of Agriculture,
Hokkaido University, 060 Sapporo, Japan.

(Received October 14, 1994)

Introduction

Tractor use in Nigeria (the first author's home country) is on the increase due to deliberate government policies to boost food production. Even though there exists the problem of fragmented land holdings, Nigerian farmers are now forming cooperatives, joining their lands and making mechanization feasible. Presently holdings of 100–10,000 ha are common. Although, Nigeria imported different types of tractors and trailers in the past, with the establishment of two tractor assembling plants in the country, the most common tractors are the products of these plants, that is, Fiat and Steyr models.

Tractor, the most common self-propelled machine in agriculture, rough-terrain forklifts and all-terrain vehicles are increasingly used all over the world. Trailed machines such as manure-spreaders and slurry tankers are also common, and trailers are standard equipment. In forestry, most machines are self-propelled, including skidders, forwarders, harvesters and processors. The tractor is used in combination with the trailer to convey farm workers to and from the farms, farm produce from the farm to local markets and to stores. The tractor and implement, both trailed and mounted also have to move from farm to farm in some cases on unpaved hilly roads because the individual farms are small and the farmers do not own tractors individually. Operation of tractor-implement combinations under these conditions can be likened to operation on a compound slope along different slope angles and different heading angles. The behavior of the system under such conditions and their behaviour on slopes poses an interesting off-road vehicle dynamics problem which requires better understanding.

Although a lot of resources have been expended in the last six decades on research into tractor stability and dynamics in different countries, tractor accidents are still many. Research must therefore continue, especially in the area of tractor-implement combinations, since this area has received little attention and the tractor alone is relatively stable. Earlier reviews of the subject was presented by Masayuki¹⁾, Grecenko²⁾ and Kim and Rehkugler³⁾. Two major trends

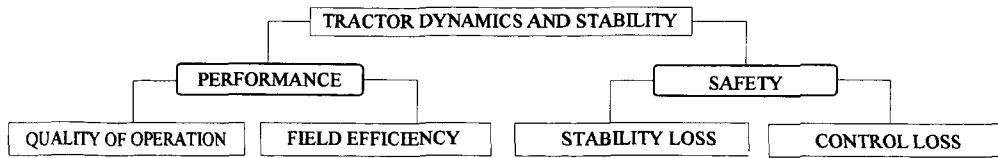

Fig. 1 Summary of the problem of tractordynamics and stability

(Figure 1) in the requirements of operators of tractors are dictating the directions of research and development. The first is the demand for higher levels of operator comfort and greater safety of operations. The second is the demand for better performance. This is not limited only to off-road operations but extends to travel on the road. This paper reviews the extent of research into tractor dynamics and tractor-implement combination dynamics combining the two trends. Emphasis will be laid on operation on slopes since critical situations are more likely to occur here.

Tyre forces play a central role in the behaviour of tractors, for this, they are discussed in the first part of this review. Other sections treat the problem of safety, performance respectively. Since the tractor is almost always operated in combination with implements, one section has been devoted to the discussion of research in to tractor-implement combinations.

Forces on Agricultural Tyres

Inasmuch as the performance of a tractor — the motions accomplished in accelerating, braking, cornering and ride is a response to forces imposed, much of the study of tractor dynamics must involve the study of how and why the forces are generated. The dominant forces acting on the tractor are produced from the ground. A knowledge of forces generated by agricultural tyres on hard and deformable surfaces is necessary in order to predict tractor handling and stability adequately. It is worth noting that the term "handling" is often used interchangeably with cornering, turning, or directional response, but there are nuances of difference between these terms. Cornering, turning, and directional response refer to objective properties of the vehicle when changing direction and sustaining lateral acceleration. On the other hand, handling adds to this the vehicle qualities that feed back to the driver affecting the ease of the driving task or affecting the drivers ability to maintain control.

To obtain optimum performance from an off-road vehicle, it is necessary to understand the interaction between the tyres and the medium on which it operates. The size and shape of the contact area depends on the structural properties of both the tyre and the soil. Tyre force is defined as an external force acting on a wheel. The tyre force has three mutually perpendicular components. The longitudinal force is the component of the force acting on the tyre by the ground

in the ground plane and parallel to the intersection of the wheel plane. Lateral force is the component of the force acting on the tyre by the ground in the ground plane and normal to the intersection of the wheel plane with the ground plane. The normal force (radial force) is the component of the force acting on the tyre by the ground which is normal to the plane of the ground. The normal force has a negative magnitude, it is equivalent to the negative of the vertical wheel load. The point of application of these tyre forces is the intersection of the wheel plane, the ground plane directly under the wheel center, and the plane passing through the wheel center, perpendicular to the ground and wheel planes (Fig. 2).

The tyre force normal to the ground is modeled by assuming the tyre could be represented by a spring plus a damper system, which has a point contact with the ground surface. The selection of a tyre model consisting of a spring plus damper with point contact with the ground surface necessitates that the surface specified be compatible with this model. In particular, the ability of the pneumatic tyre to envelope sharp obstacles must be considered. Thompson⁴⁾ has shown that irregular surfaces that are traversed by a pneumatic tyre can be considered smooth when this tyre model is used. Matthews and Talamo⁵⁾ and Pershing and Yoerger⁶⁾ measured agricultural tyre vertical spring and damping rates and found that in general tyre's dynamic vertical spring rate was higher than the spring rate obtained from a linearisation of tyre's static load-deflection relation. Schuring and Belsdorf⁷⁾ presented a review of the mathematical modeling of the tyre force in the vertical direction including the segmented wheel model of Lessem⁸⁾ which divides the tyre into a number of pie-shaped segments with each segment having its own radial spring. Contributions in modeling the spring properties of agricultural tyres in the vertical direction have also been

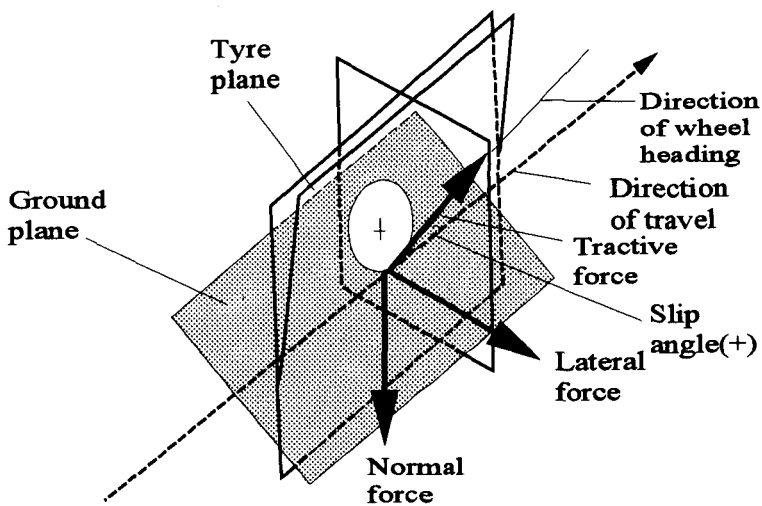

Fig. 2 Tyre forces

presented by Thompson et al.⁹⁾, Shaw et al.¹⁰⁾, Davis¹¹⁾, Laib¹²⁾ and Th. Barrelmeyer et al.¹³⁾.

From above discussion, radial force is given by:

$$N = c\dot{x} + kx \quad (1)$$

where,

N =radial force, [kN]

c =damping coefficient of the tyre, [kNs/m]

k =stiffness of the tyre, [kN/m]

x =radial deflection of the tyre, [m]

\dot{x} =deflection rate, [m/s]

Modeling of the circumferential force properties of tractor tyres has also received much attention due to their importance in the description of performance. The circumferential forces include: rolling resistance, traction and braking forces.

The motion resistance force on an unpowered wheel has commonly been predicted by the product of motion resistance ratio and the normal load on the wheel. The work by Wismer and Luth¹⁴⁾ presented a method of simulating the tractive performance of agricultural tyres through the use of a mathematical formulation to fit the form of many experimentally determined net tractive coefficient-drive wheel slip relations.

This relation takes the following form :

$$\mu = A(1 - e^{-Bs}) \quad (2)$$

where,

μ =the coefficient of net traction

A =the maximum obtainable value of tractive coefficient

B =determines the "shape" of the curve

s =drive wheel slip

$$s = 1 - \frac{v_f}{r\omega} \quad (3)$$

where,

v_f =component of the wheel center velocity parallel to the line-of intersection of the wheel and the ground plane, [m/s]

r =effective rolling radius of the tyre, [m]

ω =angular velocity about the axle, [1/s]

From above,

$$T = \mu_T N \quad (4)$$

where,

T =traction force, [kN]

μ_T =coefficient of traction

$$R = \mu_R N \quad (5)$$

where,

R = motion resistance force, [kN]

μ_R = motion rolling ratio

Both traction and motion resistance forces vary with ground conditions, wheel slip and wheel load.

The braking force properties of agricultural tyres have been the least investigated. The braking force coefficient as a function of wheel load, wheel slippage, and ground conditions similar to the traction or motion resistance ratios could be developed and applied to estimate the braking force that the ground can generate. This, although, has been used in the development of automatic skid controls for automotive braking systems, it has not been applied to the analysis of agricultural tyre braking.

It is a well established fact that the lateral force developed by agricultural tyres play a leading role in the simulation of the handling behavior of a tractor. It is the generation of these forces that cause the tractor to turn rather than the kinematics established by a given steering geometry. Lateral force is a function of the radial force, camber angle, inflation pressure, tyre construction, slip angle and ground conditions. For powered wheels, the lateral force varies with traction and braking forces (Krick, 1973)¹⁵. A number of efforts were made to express lateral force by linear, exponential or polynomial functions of the radial force, traction force, and slip angle for different tyre constructions and ground conditions (see review by Horton and Crolla, 1984)¹⁶.

As pointed out by earlier reviewers, due to variations in the results obtained by various researchers of forces on agricultural tyres, it is difficult to accept any of the formulae presented for general use in simulating tractor motion^{17,18}. The following general formulation is, however, common to most of the models:

$$L = C_1 N \quad (6)$$

where,

L = lateral force, [kN]

C_1 = lateral force coefficient which is a function of slip angle α

Slip angle α is defined as the angular difference between the direction the tyre is headed (as determined by the dynamic forces on the tractor) and the direction the tyre is steered (as determined by steering wheel movement). Hence,

$$\alpha = \tan^{-1} \frac{v}{u} - \delta \quad (7)$$

α = slip angle, [rad]

v = lateral velocity, [m/s]

u = longitudinal velocity, [m/s]

$\tan^{-1} \frac{v}{u} - \delta$ defines the direction of tyre heading

δ defines the direction in which the tyre is steered.

Safety

As the agricultural tractor originally evolved from its steam prototype, operating stability was largely taken for granted. Tractors of that time were ponderous and their low drive wheel lugs afforded little penetration in to the soil, the resulting traction was poor, and the ratio of drawbar pull to total weight was low. As long as field upsets were non-existent, stability characteristics posed no problems. Tractor stability became a matter of concern ever since the development of the relatively light weight tractor from the massive steam engines of the past. This concern is reflected as far as the 1920s with the now classic investigations of tractor static and dynamics by McKibben^{19),20)}.

Tractor overturning accidents on slopes, which always have serious consequences for the farmer, are of two categories. These are stability loss which is when the tractor overturns directly, and control loss which is when the tractor slides bodily downhill before overturning. These accidents arise in a wide variety of circumstances: tractor alone, tractors with mounted and trailed equipment, on steep slopes and on gentle slopes.

Hazards on a slope are present when a tractor is traveling; downhill, changing direction, crossing the slope or climbing uphill. Sliding downhill will occur if the ground is too slippery for the tractor to remain under control; this is common on grass fields, and is also likely on loss surfaces. Skidding or overturning on the other hand will occur when cornering at too high speed. Sideways overturning will occur on too steep slopes and on rough ground. Accelerating uphill will cause rearwards overturning or slipping, while with certain designs the machine will tip forwards when braking during a descent.

The use of rollover protective structures ROPS will no doubt reduce the number of fatalities and injuries, but avoidance of the overturns altogether would be the optimum situation. If the tractor is never unstable, yet is still used at maximum output over the wide range of terrain, then the operator and the equipment manufacturer would have performed their jobs.

1. Research Methods

The goal toward tractor safety will be achieved through the observation and analysis of the tractor dynamics under numerous field operating conditions. Research into tractor stability and dynamics could be experimental, computer simulation or computer simulation and experimentation. The use of experimental methods only, to study tractor stability and dynamics is limited. The limitations arise because in the first place, such experiments would be slow and, very

Table 1. General Assumptions in Modeling of Tractor Motion

Properties	Assumptions
Dynamic properties of the tractor	a) tractor is a right body b) tractor is symmetrical with respect to a plane perpendicular to the rear axle and passing through its mid-point c) dynamic properties are represented by the tractor mass, moments and products of inertia
Properties of terrain	a) terrain surface is non-deformable b) terrain surface is planar
Interactions between the tyres and the terrain	a) wheel ground reactions acts at a single ground contact point at each wheel b) the tyre can be replaced by a spring and a viscous damper

expensive and in some cases could be hazardous to both life and equipment. Secondly, it will be difficult to have such experiments repeated for numerous operating conditions. For these reasons computer simulation is considered one of the most powerful methods for the study of tractor stability and dynamics. It is able to predict the response of a tractor to external disturbances and given terrain conditions. Computer simulation models, however, require experimental validation either using scale-model or full size tractor. This leads to the third method i.e. computer simulation and experimentation. In the modeling of tractor motion, the following general assumptions are usually made. They are those related to the dynamic properties of the tractor, properties of the terrain over which the tractor operates, and interactions between tractor and terrain, Table 1.

These assumptions are extreme idealization as the tractors are not symmetrical nor is the terrain non-deformable. The deformability of the terrain depends on the relative strength of the terrain and the wheel. Soft soils beneath a highly pressurized pneumatic tyres are deformable. Attempts have also been made to describe terrain-wheel interaction by a contact patch which is a closer approximation of the actual situation. Modeling interactions with deformable surfaces is a subject still requiring much work. Another area requiring future work is the establishment of guidelines for selecting an optimum wheel to ground model for a given set of simulation conditions. The choice of an appropriate model depends on the wheel force to be simulated and the properties of the terrain surface. A number of arguments can be advanced to question these assumptions. Their validity, however, would be justified, if the model derived from the assumptions can generate acceptable predictions of vehicle motions.

Computer simulation models depending on the parameters considered are

either static, quasi-static or dynamic. Under static conditions a tractor will lose stability and start to overturn when the normal to ground component of a wheel load becomes zero. A modification of static models is the quasi-static models. They take into account constant speed turning, and constant acceleration or deceleration. Slope values at which zero wheel load is experienced is predicted just as in the case of static model.

Dynamic models attempt to predict the conditions necessary for overturning. This is considerably more complex than predicting zero wheel load because it is also necessary to predict the motion of the machine while it lifts off the ground and passes through the point of balance. There are two main problems in obtaining a good dynamic model. The first is simulating the interaction between the vehicle tyres and the ground, and the second is predicting the behaviour of the whole vehicle in response to random ground inputs.

2. Stability Measurement

Schwanghart²¹⁾ estimates the following values of operating limits of different machinery for different crops; sugar beet 7°, potatoes 11°, cereals 14°, forage 17°, and grazing 24°. These limits depend on the machinery used and relate only to traction limits for pulling harvesting equipment. There is a wide variation between the stability limits of different types and designs of machine. The two or four wheel drive tractor will tip at a side slope of 36° extending the track width by 210 mm can increase this value to 42°. Trailed machinery are generally less stable than the tractor, with most stability values in the range 20° to 30°.

In Czechoslovakia, tractors working on slopes were to be marked with a label indicating the rated operating slope ROS which has been determined as 1/3 of the minimum static stability in degrees. This resulted into problems because research results revealed that ROS is a function of velocity and should be determined by finding the smallest value of slope for a given speed by different criteria on condition that either the resistance to overturning or the resistance to sliding reach the defined limit²²⁾.

Static stability can be measured on a tilt table, yet so far as is known, this is not required under official procedures of any country except in Norway. The new test of static stability which requires only portable weighpad equipment and an inclinometer is probably the easiest and least expensive method of assessing static stability. It is based on measuring the weight transfer on a moderate slope and then predicting the slope angle where an uphill wheel will carry no load²³⁾. The dynamic effects of cornering, acceleration and deceleration can be calculated directly in terms of adjustments to the static stability limit, provided these effects remain constant.

Testing a machine leads to the concept of determining an index of stability for the machine. One proposal being made is that the index is a slope value, defined as the minimum slope on which a dynamic test causes the machine to tip

halfway towards overturning. A machine with a high stability index will be more stable than a machine with a low stability index. Thus the index will be a valuable indicator of machines which are safer to use on slopes and it can be used to propose maximum operating slopes for individual machines. However, the index will not in itself define a safe slope because it will always be possible to cause an overturn, even on level ground, by violent manoeuvres and harsh driving. A stability index will provide a standard measure with which to compare the stability of different machines²⁴⁾.

3. Types of Overturns

Overturning accidents arise from reaching the limit of static stability, reaching stability limit under dynamic conditions, or sliding out of control. An agricultural tractor may overturn in any of the following three directions: rearwards, sideways or forwards. Of the three types of overturning situations, sideways overturning have been discovered to occur most often resulting in about 70 % of the total overturning accidents. It has also understandably received most attention in terms of research efforts. Forward overturning accidents are very rare and their study has received little attention. Although rearwards overturning covers just about 30 % of reported tractor overturning cases, they are more likely to result in fatalities than sideways overturning accidents²⁵⁾. They have, therefore, received considerable attention.

3.1. Rearward overturning

Rearward stability has been a subject of considerable research since the development of the lightweight tractors from their massive steam tractor predecessors. Among the earlier works are those of Worthington²⁶⁾, and Sack²⁷⁾ which treated the resulting differential equations of motion as algebraic equations since then methods of solving the often non-linear equations were either few or not in existence at all. The advent of digital and analog computers encouraged the development of more complex and accurate mathematical models such as those by Raney et al.²⁸⁾, Goering and Buchele²⁹⁾, Pershing and Yoerger³⁰⁾, and Koch et al.³¹⁾. These works form the theoretical basis for the generally accepted principles of safe tractor hitching which include, never to hitch a drawbar load at or above the rear axle and the stability of a tractor will be increased by lowering the hitch point and/or moving it to the rear.

Smith and Liljedahl³²⁾ developed a two part model to simulate rearward overturning of agricultural tractors. The first part considers the tractor as rotating about its center of gravity when all wheels are in contact with the ground while the second part considers the tractor frame as rotating about the rear axle during the actual overturning. The parameters of the model were determined for a typical agricultural tractor. The tractor was instrumented to measure rear axle torque and angular acceleration. Additional instrumentation was also made to remotely engage the clutch and shut off the engine of the

tractor. The overturning situation studied was that of application of power to a tractor whose drive wheels were solidly lodged. A more recent work considering the influence of drawbar position on tractor rearward stability has been presented³³⁾. The analytical procedure provides a means of evaluating the effect of drawbar position on tractor static rearward stability that considers the limiting effects of traction conditions and available axle load. Static stability is improved by moving the centre of gravity forward and lowering the angle of draft.

3.2. Sideways overturning

A conventional tractor may tip sideways about two axes. The overturning motion first takes place about an axis connecting the hinge point of the front axle to the contact point of the rear tire remaining on the ground during the initial overturning motion. Eventually, the tipping part of the tractor strikes a stop on the front axle assembly with further tipping of the entire tractor taking place about the axis connecting the contact points of the front and rear tires on the side of the tractor about which the initial motion took place, Figure 3. Smith et al.³⁴⁾, based on the discussion above used vector analysis to describe three-dimensional motion of sideways overturning of a farm tractor. The tractor body consists of six degrees of freedom: 3 translational and 3 rotational (Fig. 3). The angular motion of the tractor motion is described by equations in terms of four Euler parameters rather than the three commonly used Euler angles. Whereas the Euler angles become undefined when certain angles of rotation are experienced, the Euler parameters remain stable while also providing normalized symmetric relationships for any orientation. This allows for simulation of large amplitude motions³⁵⁾.

Rehkugler³⁶⁾ simulated the motion of a 4WD articulated steer tractor over a sloping earth embankment for three steering alternatives of both a dual wheel

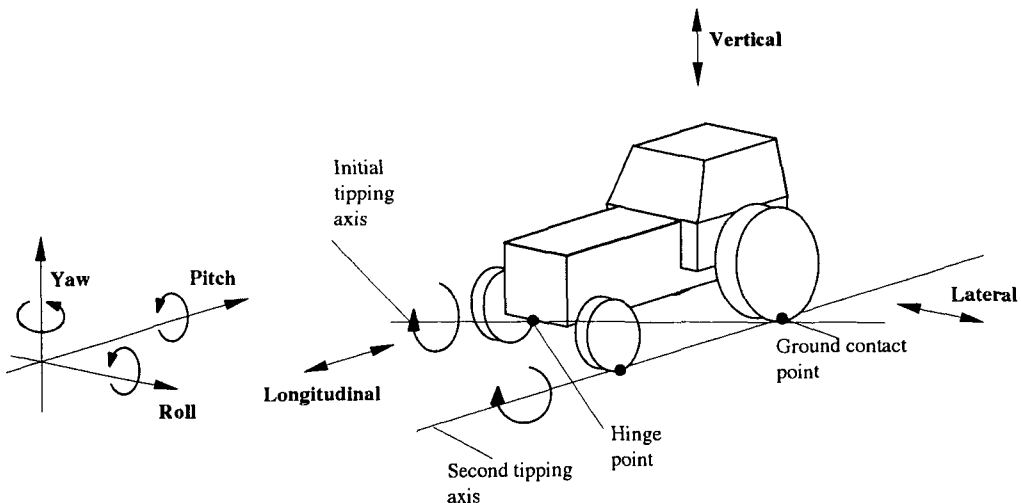

Fig. 3 Degrees of freedom of a tractor and tipping axes in a sideways overturn

and a single wheel tractor. Steering down the embankment was shown to be a possible maneuver to prevent an overturn. His simulation showed that steering straight ahead on a 50° slope soil embankment would likely result in a side overturn of both a dual and single wheeled articulated steer 4WD tractor.

Spencer and Gilfillan³⁷⁾ observe that field records obtained from a tractor moving at constant speed suggest that measurements of energy input to ground irregularities causing roll or pitch of the machine represent a random stationary Gaussian process, for which a first passage time can be calculated. This procedure enables the length of time from the start of use of the tractor within which the first occasion of overturning may occur be considered along with the probability of stability being lost. It also offers a method for estimating the stability of a tractor on slopes having different ground surfaces by the use of data obtained in safety on level land.

Chisholm³⁸⁾ developed a mathematical model based on the force and displacement equations of equilibrium at each point where the tractor or cab makes contact with the ground during overturning. The model covers overturning phase, in addition to impact, by including tyre side forces relationships and damping terms. Survey results show that the two types of accidents likely to result in high energy being absorbed in a roll over protective structure ROPS are: a tractor falling over the edge of a bank 2 to 4 meters high, with a slope of 0 to 40 to the vertical and accidents involving multiple rolls.

A two-dimensional mathematical model was developed to describe the dynamic behaviour of a body in multiple point contact with the ground, where the flexibility of the body and ground can be represented by non-linear forces deformation characteristics. The transverse ground forces was assumed to bear a Coulomb-type relationship with the normal force, where the friction coefficient varied continuously according to sliding velocity and other variables. The model was validated by full-scale experiments in which a tractor with an instrumented experimental safety frame was overturned down a simulated bank about 2 m high³⁹⁾. The model was also used to study the effect of parameters on energy absorbed in a ROPS during motion down a steep bank⁴⁰⁾.

Kelly and Rehkugler⁴¹⁾ showed in their research the velocity at which a critically steered tractor will overturn on a given bank slope. The permissible bank slope would approach the static angle of tip, as the velocity approaches zero. On a flat terrain there will be a minimum velocity which will cause overturn. Twenty one variables identified to influence tractor overturn are presented in Table 2. Given a particular slope angle, the minimum velocity at which a tractor will overturn was determined.

Rehkugler (1982)⁴²⁾ conducted a full-scale verification study to establish the level boundaries of confidence one may expect in the use of SIMTRAC(a computer simulation program) during high speed turns on level terrain. A small utility tractor was accelerated to maximum travel speed in a straight line and

Table 2. Parameters Affecting Stability⁴⁰⁾

Type	Parameter	Dimensions
Static	a) tractor mass	[kg]
	b) tread width	[m]
	c) wheelbase	[m]
	d) center of mass height	[m]
Dynamic	a) inertia	[Nms ²]
	b) tyre damping ratio	[Ns/m]
	c) tyre spring rate	[N/m]
Initial conditions	a) initial velocity of center of mass	[m/s]
	b) angular velocity	[rad/s]
	c) acceleration of center of mass	[m/s ²]
	d) angular acceleration	[rad/s ²]
Driver controlled	a) external forces	[N]
	b) steering forces	[N]
	c) braking forces	[N]
	d) engine torque	[Nm]
Terrain properties	a) gross coefficient of traction	—
	b) lateral tyre force coefficient	—
	c) tyre slip angle	[rad]
	d) rolling resistance	[N]
	e) terrain dimentions	[m]
	f) slope angle	[rad]

then steered as rapidly as possible in one direction in a free wheeling mode with no braking or engine power being applied. Tractor position as a function of time was recorded for duplicate runs for this test on a flat surface. The same tests were then simulated with SIMTRAC to compare with the field test. Reasonable agreement was achieved.

Highway Vehicle Object Simulation Model HVOSM was modified for simulation of agricultural tractor dynamics. A battery powered scale model tractor was used to perform experimental runs for the partial validation of the computer model. Satisfactory agreements were obtained on pavement⁴³⁾. However, since agricultural tractors are operated on soil, further refinements of the program and the parameters will be necessary before a completely satisfactory simulation is achieved. Song et. al⁴⁴⁾ recognized this necessity and further modified HVOSM and the associated computer programs to simulate the general dynamics of a tractor on soft ground by incorporating some soil parameters. The simulated results were verified for tractor overturns using a powered model tractor. The results showed that the modified HVOSM allowed close prediction of tractor

dynamics.

A mathematical model combining the three major factors (sloping grounds, bumps, and turns) responsible for tractor overturns was developed by Feng and Rehkugler⁴⁵⁾. Two cases were considered, the situation where the tractor has three degrees of freedom with respect to the ground; two for translation and one for rotation (three or four wheels contact the ground) and a situation where the tractor has four degrees of freedom; two for translation and two for rotation (only two wheels keep contact with the soil). Newtonian Mechanics was used in the first case, while Lagrange equation was applied to the second case. Spencer and Crolla⁴⁶⁾ presented a procedure for studying control of tractors on sloping ground. A remote controlled tractor was used to verify the developed model. To study sideslip phenomenon of agricultural tractors, Machida^{47),48)} used a single wheel sideslip analyzer and a model tyre on a plywood. Sideslip was found to be a function of slope angle and slip. Noh and Erbach⁴⁹⁾ recently used the variational vector approach that uses relative generalized coordinates in Cartesian space to develop a semi-recursive dynamic algorithm which was evaluated by modeling an agricultural tractor. Apart from this semi-recursive dynamic algorithm method, modeling of tractor dynamics has either been achieved through vectorial mechanics (Newtonian approach) or through variational approach to mechanics (Lagrangian dynamics).

Field Performance

The prediction of tractor-implement field performance has been attempted many times in the past. Simulation of tractors for predicting field performance using a graphical method was presented by Grecenko⁵⁰⁾. The parameters plotted were wheel slip, implement draft, engine power, field speed, combination of tractive and transmission efficiency and fuel consumption. To determine the fuel consumption for steady-state operation, the graph was entered at the appropriate draft, engine power, wheel slip and transmission efficiency. Sclegel and Morling⁵¹⁾ developed a simple calculator for estimating the forward speed required to maximize tractor work rate when ploughing. The mathematical model used to produce the calculator was, however, a very simple one and did not include the effects of, for example, tyre size and type and condition of soil. Zož⁵²⁾ developed a graphical solution technique for two-wheel drive tractor performance. Data needed were travel speed, axle load, engine power, type of hitch and soil condition. Using the graphical technique, the ratio of drawbar pull to rear axle load and tractive efficiency could be determined. This predictor was reported valid only for steady-state performance of 2WD tractors equipped with single wheel drive wheels.

Wismer and Luth⁵³⁾ produced a set of empirical equations which could be used to predict the field performance of field vehicles. The equations utilize the

mobility number developed by Freitag⁵⁴⁾ and further extended by Turnage⁵⁵⁾. A transmission torque balance was used by Kolozsi and McCarthy⁵⁶⁾ in developing a computer simulation of tractor performance. The torque prediction equation relied upon measuring the independent variables in one gear prediction. Smith and Yoerger⁵⁷⁾ developed a mathematical model for predicting variations in the forward motion of farm tractors due to varying drawbar loading. They then used the model to study the translational frequency response characteristics of a tractor subjected to a periodic drawbar load. Seven degrees of freedom were considered in developing the mathematical model. These were longitudinal and vertical translation of the tractor center of gravity, pitch of the tractor about its center of gravity, angular rotation of the inner and outer parts of the drive wheel, angular rotation of the engine, and angular motion of the engine governor flyweights. The equations of motion were developed using the principles of Lagrangian dynamics. The power train was assumed as storing potential energy due to torsional motion of the drive train. Drawbar pull was varied by a sinusoidal function.

The development of empirical equations for predicting the performance of a tractor-plough combination was presented by Gee-Clough et al.⁵⁸⁾. The empirical equations were considered accurate enough for the computational method presented to be used for a general parametric study of tractor-plough field performance. In another study, Yasuo et. al⁵⁹⁾ developed climbing tractive performance charts. More recently, mathematical models describing the performance of 2WD and 4WD tractors were developed by Summers et al.⁶⁰⁾. The simulation model was validated by simulating the lugging ability of the Nebraska Tractor Tests. Reasonable agreements were obtained. A method to obtain theoretical traction characteristics for a tractor as a function of its engine performance, total transmission gear ratio, dimensional parameters, and drawbar performance on concrete for two gears was proposed by Souza and Milanez⁶¹⁾.

In order to improve the performance and stability of agricultural tractors on slope, a conventional tractor was modified and tested^{62),63),64)}. A major modification was made to the rear axle on which the centres of the drive wheels were at different heights.

Tractor-implement Combinations

Although much research has been done on the dynamics and stability of an agricultural tractor alone in many countries (Table 3), the combination with a trailer or other implements has received less attention. Gilfilan^{65),66)} reported work on the effect of slopes on the forces and moments acting on tractor-implement combinations operating uphill or downhill.

Spencer⁶⁷⁾ examined conditions under which the overturning stability and directional control of two-wheeled drive tractors with mounted or towed imple-

Table 3. Major Institutions Conducting Tractor Dynamics Related Research

Continent	Institution	Major Research Areas
Africa	Federal University of Technology, Minna, Nigeria.	Dynamics of tractor-implement combinations on slope
	Federal University of Technology, Owerri, Nigeria.	Tractor-trailer combination performance
	Obofemi Awolowo University, Ife, Nigeria	Stability
Asia	Hokkaido University, Sapporo, Japan.	Vibration Dynamics of tractor-implement combinations on slope
	Seoul National University, Seoul, South Korea.	Stability and Dynamics
	Beijing Agricultural Engineering University, Beijing, China.	Stability and Handling
Europe	Technical University, Berlin, Germany.	Ride
	Technical University, Munchen, Germany.	Stability
	Scottish Centre of Agricultural Engineering, Penicuik, United Kingdom.	Vibration, Stability and Control
	AFRC Institute of Engineering Resaerch, Silsoe, Bedfordshire, United Kingdom.	Stability, Control and Vibration.
	University of Leads, United Kingdom	Vibration, Stability and Control
	Academy of Agriculture, Wroclaw, Poland.	Traction and Braking Performance of Tractor-implement Combinations on Slope
	Research Institute of Agricultural Machinery, Prague, Czechoslovakia	Stability and Performance
America	Cornell University, Ithaca, N.Y, U.S.A	Stability and Dynamics
	Purdue University, Purdue, U.S.A	Stability and Dynamics
	Kansas State University, Kansas, U.S.A	Dynamics
	Nebraska University, U.S.A	Performance and Stability

ments are lost on sloping ground. The problems examined were restricted to those arising in steady state straight line motion. Control loss is dependent on the ground conditions. In the absence of sufficient data to provide the general traction, side force and braking characteristics of tyres, his work was based on friction concepts. His work was to extend the polar diagrams earlier used by Daskalov⁶⁸⁾ and Reichman⁶⁹⁾ independently to show combinations of slope angle and heading angle at which instability sets in (which was confined to vehicles not acted on by external loads and to stability loss, which occurs when the normal to ground reaction of one of the machine's wheels becomes zero) to instability

Table 4. Loads on Steerable Axle⁷⁰⁾

Total instantaneous weight of a tractor (tractor with attached implements) [kg]	From the total instantaneous weight of a tractor (tractor with attached implements in %)
Up to 3200	20
From 3201 to 4500	19
From 4501 to 7500	18

resulting from external loading and also to take account of wheel-ground adhesion being inadequate to withstand braking, side or traction forces. The driver will also lose control when the wheel-ground adhesion is insufficient for equilibrium, in the ground plane, to be maintained. The computed stability boundaries did not however, take account of rough ground so it is to be expected that the actual boundaries will occur at smaller values of slope angle than are indicated in the diagrams. Other risks also identified with a two-wheel drive tractor are: the ability to ascend slopes it cannot safely descend, and the decrease in the safe descent slope with a fully mounted fertilizer spreader as emptying proceeds.

Another work on tractor-implement stability was presented by Habarta⁷⁰⁾. His study was predicated by a regulation which required any tractor while traveling on any ground to have at least 20 % of its total weight on its front axle. As at 1967 in Czechoslovakia, 42 % of the tractors surveyed did not quite meet this requirement. Manufacturers of agricultural machinery demanded justification of the required 20 %. Three groups of tractors were studied (Table 4). To secure longitudinal stability and manoeuvrability of a tractor, it was considered to be sufficient if the load on the steerable axle under static conditions on level plane is at least as shown in the table.

Hudson et al.⁷¹⁾ developed a model to study the dynamic behaviour of a particular tractor while pulling dynamic or static loads. Instability was found to be related to the combination of slope, timing and peak load of the forcing function and rebound effect of the front wheels. Forward and angular reactions of the tractor were observed to be similar with both static and dynamic loading because the inertia of the tractor suppressed the influence of dynamic loading as time proceeded. A dynamic load whose average if applied statically would not cause instability can cause instability. Crolla and Hales⁷²⁾ developed simple equations to study lateral stability of a tractor-trailer combination. To obtain the equations of motion, they equated the rate of change of linear and angular momenta to the external forces and moments and then eliminated the hitch forces. Interesting as their studies were, lack of data on the side force characteristics of agricultural tyres limited their wide application. The present configuration of tractor and trailer combinations used for farm transportation was observed to

have severe stability problems at speeds higher than 9 m/s and also during breaking. Locking the tractor rear wheels results in a major instability known as jack-knifing. Locking the rear axle results in a less severe, but potentially dangerous instability situation known as tractor swing. Locking the front axle has a stabilizing effect on the combination.

Static loss of stability due to driving a tractor onto a smooth slope so steep that the tractor overturns is rare. This is because a tractor is reasonably stable. A typical two-wheel drive tractor must be driven onto a slope of 33° before it reaches its stability limit, which is much steeper than the slopes on which most accidents occur; the reason is that very few accidents are caused by simple static overturning. A tractor with a front loader being used to lift a heavy tree trunk overturned as it was turned downhill on a slope of 8° due to a shift in the overall centre of gravity. Ground roughness which may also be the cause of dynamic stability loss if a tractor is driven at high speed and the tractor wheels start to bounce was found to be responsible for static stability loss as a result of the existence of a local steepness. Speed, acceleration and cornering are dynamic conditions which affect stability. Stability and control loss slopes are likely to coincide, not so much due to dynamic effects, but due to loads added to the tractor. For control loss calculations one parameter which is always difficult to assess is the braking force coefficient between the tyres and grass. The wide range of accident circumstances and the fluctuating grass grip are the two main reasons that it has been difficult to forestall accidents⁷³⁾.

Hunter and Owen⁷⁴⁾ reported on various types of accidents involving tractor-implement combinations on slopes. They described stability and control loss accidents to show the varied circumstances in which they occur and to demonstrate the wide range of equipment involved.

A stability-indicating system for use in minimizing the occurrence of front-end loader (FEL) roll over has been developed⁷⁵⁾. The following operator controlled factors contribute to the loss of stability of a FEL: weight of the load in the bucket, the bucket height, the yaw angle of articulation, its velocity, and the degree of braking. It is observed that while any of these factors could be a principal contributor, it is usually a combination of these parameters that produces an accident.

Hunter⁷⁶⁾ analyzed the stability of trailed tankers on slopes. Due to movement of the center of gravity the tanker is less stable when partly full than when completely full, with the result that the tanker becomes progressively less stable as its contents are discharged during work. Sakai et al.^{77),78)} developed a mathematical model to study the dynamic behaviour of a tractor-vibrating subsoiler system. The validation of their model showed a considerable agreement with simulation data obtained. The virtual hitch point VHP was observed to have a considerable effect on the vertical acceleration under the drivers seat.

To study the steering and control characteristics of a vehicle, the design of

tractive system and the automatic guidance system, steering stability of a tractor-trailer combination, evaluation of passing ability of a vehicle, the design of roads etc., the motion and the trajectories in the turning process are important. Zhen-an⁷⁹⁾ realized this importance and investigated the trajectories of wheels in a vehicle-trailer combination turning process. A study on the braking performance of tractor-trailer combination was done by Asoegwu⁸⁰⁾. Tractors with balanced and unbalanced trailers were studied. The deceleration rate of a tractor-implement combination depends on, the type of trailer (balanced or unbalanced), whether the trailer is equipped with brakes or not, load carried by the trailer and the surface on which the combination travels. Five analytical mechanics methods to formulate dynamic equations for tractor-trailer system handling model were presented recently by Xie et al.⁸¹⁾. General-purpose, large displacement computer simulation programs which utilize these methods have also been briefly discussed. Traction parameters of tractor-implement combinations on hills has been presented^{82),83)}. Motion resistance, acceleration and traction forces on slopes of up to 16° were measured.

Another attempt at establishing the performance of tractor-implement combination was done by Zhang and Terao⁸⁴⁾. They studied the performance of tractor-trailer combinations meant for farm use. Tractor-trailer performance was measured on both concrete and a harvested field. The necessity to equip trailers meant for farm transportation with brakes was stressed. They used optimal control theory to improve the performance of tractor-trailer combination.

Conclusions

Considerable research has been conducted on tractor overturning stability and dynamics on sloping ground, much of the work was connected to establishing safe operating slopes and the introduction of the roll over protective structures ROPS and their associated legislature. Many mathematical models for tractor dynamics and stability studies have been developed in the last 30 years. A lot of instrumentation has also been developed to validate most of the models either by using scale-models or full-size tractors⁸⁵⁻⁸⁷⁾. The static stability, which in itself has unexpected complexities depending on the design of the vehicle is, however, still better understood than the dynamic stability. In agriculture, over half the overturning accidents with machines are due to exceeding their slope capabilities, while only one quarter can be blamed on carelessness or misjudgment of the driver.

Computer models of tyres already exist, and they are standard elements in advanced commercial modeling packages such as, ADAMS, DAMS, DADS etc., but their use is still limited by the availability of field data for real tyres and real ground.

Little work has been done on steering control and directional stability characteristics of tractor-implement combinations TICs or their handling performance on slopes generally. When agricultural wheeled tractors are operated across a slope, they tend to slide down as a result of the component of the gravitational force acting on the tractor and directed down the slopes which results in lateral load transfer LLT. LLT is the vertical load transfer from one of the front tyres (or rear tyres) to the other that is due to acceleration, rotational or inertial effects in the lateral direction. The consequence of this, is that maintaining a straight-line motion or motion along a desired path becomes difficult and constant directional correction is necessitated. Other shortcomings resulting from this, are, extra power requirement, increased fuel consumption, uneven motion of operating parts in attached implements, irregular seed distribution by planters, insufficient depth of tillage and poor conditions for plant growth (Amelchenco et al., 1978) as reported by Lyasko et al.⁸⁸⁾. Current research into tractor stability and dynamics should, therefore, be directed towards:

- 1) Harnessing already available models and research results for the optimization of the tractor configuration in particular and tractor-implement outfit in general.
- 2) Modeling the lateral dynamics of tractor-implement combinations on slope not only for stability analysis, but also for performance analysis.
- 3) Establishment of agricultural tractor tyre parameters pertinent to modeling its dynamic behaviour.

References

- 1) Masayuki K.: Research in to Tractor Stability Abroad. Journal of the Japanese Society of Agricultural Machinery, 37(4): 626-629, 1975 (In Japanese).
- 2) Grecenko A.: Operation on Steep Slopes. State-of-the-Art Report. Journal of Terramechanics 21(2): 181-194, 1984b.
- 3) Kim Uk K. and Rehkugler G. E.: A Review of Tractor Dynamics and Stability. Transactions of ASAE. 30(3): 615-623, 1987.
- 4) Thompson, L. J., Liljedahl, J. B., and Quinn, B. E.: Dynamic motion Response of Agricultural Tyres. ASAE Paper 70-148, 1970.
- 5) Matthews, J. and Talamo, J. D. C.: Ride Comfort for Tractor Operators. III. Investigation of Tractor Dynamics by Analogue Computer. J. of Agricultural Engineering Research 10(2): 93-108, 1965.
- 6) Pershing R. L. and Yoerger R. R.: Simulation of Tractors for Transient Response. Transactions of the ASAE. 12(5): 715-719, 1969.
- 7) Schuring, D. and Belsdorf, M. R.: Analysis and Simulation of Vehicle-terrain Interaction. Cornell Aeronautical Lab. Technical Memorandum No. VJ-2330-G-56, 206p, 1969.
- 8) Lessem, A. S.: Dynamics of Wheeled Vehicles. Report I: A Mathematical Model for the Traversal of Rigid Obstacles by Pneumatic Tyres. U. S. Army Engineer Waterways Experiment Station, Vicksburg, MS, 1968.
- 9) Thompson, L. J., Liljedahl, J. B., and Quinn, B. E.: Dynamic motion Response of

- Agricultural Tyres. Transactions of ASAE 15(2): 206-210, 1972.
- 10) Shaw, L. N., Johnson W. H. and Hamdy M. Y.: Analysing Dynamic Response of a Semi-mounted Implement. Transactions of the ASAE 15(6): 1059-1063, 1972.
 - 11) Davis, D. C.: A Radial Spring Terrain Enveloping Tyre Model. Vehicle System Dynamics 4(1): 55-69, 1975.
 - 12) Laib, L.: On the Dynamic Behaviour of Agricultural Tyres. Journal of Terramechanics 16(2): 77-85, 1979.
 - 13) Barreilmeyer, Th., Armbruster, K., Langenbeck, B. and Kutzbach, H. D.: The Model for Vertical, Longitudinal and Lateral Forces on Driven Angled Tractor Wheels. Proceedings International Conference ISTVS, Vol. II, 1993
 - 14) Wismer, R. D. and Luth H. J.: Off-Road Traction Prediction for Wheeled Vehicles. Transactions of ASAE. 17(1): 8-10, 14, 1974.
 - 15) Krick G.: Behaviour of Tyres Driven in Soft Ground with Side Slip. J. of Terramechanics. 9(4): 9-30, 1973.
 - 16) Horton, D. H. L. and Crolla, D. A.: The Handling Behaviour of Off-road Vehicles. Int. J. of Vehicle Design 5(1/2): 197-218, 1984.
 - 17) Crolla D. A. and Hales F. D.: The Lateral Stability of Tractor and Trailer Combinations. Journal of Terramechanics 16(1): 1-22, 1979.
 - 18) Plackett C. W.: A Review of Force Prediction Methods for Off-Road Wheels, J. agric. Engng Res. 31: 1-29, 1985.
 - 19) Mckibben E. G.: The Kinematics and Dynamics of the Wheel Type Farm Tractor. Agricultural Engineering. 8(1-7) Inclusive, 1927.
 - 20) Mckibben E. G.: Effect of Pull Upon the Effective Weight on Front and Rear Wheels of Farm Tractors. Agricultural Engineering 9(8), 243-245, 1928.
 - 21) Schwanghart, H.: Tipping and Overturning Behaviour of Tractors. Landtechnik 11: 488-492, 1978.
 - 22) Grecenko A.: Study of the Motion of Agricultural Vehicles on Steep Grass-Covered Slopes. Proceedings 8th International Conference ISTVS, 1984a.
 - 23) Owen G. M., Hunter A. G. M. and Glasbey C. A.: Predicting Vehicle Stability Using Portable Measuring Equipment. Proceedings 5th European Conference ISTVS Vol.II, 1991
 - 24) Hunter A. G. M.: A Review of Research into Machine Stability on Slopes. Presented at AG ENG 92. Agricultural International Conference. Uppsala-Sweden, June 1-4, 1992.
 - 25) National Safety Council, Accident Facts, Chicago, Ill, 1968.
 - 26) Worthington H. W.: Evaluation of Factors Affecting the Operating Stability of Wheel Tractors. Agricultural Engineering 30(3):179-182, 1949.
 - 27) Sack H. W.: Longitudinal Stability of Tractors. Agricultural Engineering 37(5):328-333, 1956.
 - 28) Raney J. P., Liljedahl J. B. and Cone R.: The Dynamic Behaviour of Farm Tractors. Transactions of ASAE. 4(2):215-218, 221, 1961.
 - 29) Goering G. E. and Buchele W. F.: Computer Simulation of an Unsprung Vehicle Part I. and II. Transactions of ASAE 10(2): 272-280, 1967
 - 30) Same as 5).
 - 31) Koch, J. A., Buchele, W. F. and Marley, S. J.: Verification of a Mathematical Model to Predict tractor Tipping Behaviour. Transactions of ASAE 13(1): 67-72, 76, 1970.

- 32) Smith, D. W. and Liljedahl, J. B.: Simulation of Rearward Overturning of Farm Tractors. Transactions of the ASAE 15(5): 818-821, 1972.
- 33) Smith D. W.: The Influence of Drawbar Position on Tractor Rearward Stability. ASAE Paper No. 84-1560, 1984.
- 34) Smith, D. W., Perumral J. V. and Liljedahl J. B.: The Kinematics of Tractor Sideways Overturning. Transactions of the ASAE 17(1): 1-3, 1974.
- 35) Davis D. C. and Rehkugler G. E.: Agricultural Wheel Tractor Overturns Part I; Mathematical Model. Transactions of ASAE 17 (3): 477-483, 1974a.
- 36) Rehkugler G. E.: Simulation of Articulated Steer Four-Wheel Drive Agricultural Tractor Motion and Overturns. Transactions of ASAE 23(1): 2-13, 1980.
- 37) Spencer H. B. and Gilfillan G.: An Approach to the Assessment of Tractor Stability on Rough Sloping Ground. J. agric. Engng Res. 24: 375-394, 1976.
- 38) Chisholm C. J.: A Mathematical Model of Tractor Overturning and Impact Behaviour. J. agric. Engng Res 24(4): 375-394, 1979a.
- 39) Chisholm C. J.: Experimental Validation of a Tractor Overturning Simulation. J. agric. Engng Res 24(4): 395-415, 1979b.
- 40) Chisholm C. J.: The Effect of Parameter Variation on Tractor Overturning and Impact Behaviour. J. agric. Engng Res 24(4): 417-440, 1979c.
- 41) Kelly J. E. and Rehkugler G. E.: Stability Criteria for Tractor Operation on Side Slopes. ASAE Special Publication, Engineering A Safer Food Machine. 145-157, 1980.
- 42) Rehkugler G. E.: Tractor Steering Dynamics-Simulated and Measured. Transactions of ASAE. 25(6): 1512-1515, 1982.
- 43) Henry Ying-Ren Chen: Dynamic Simulation of Wheel-tractor Using a Powered Scale Model. (Validation of Highway-Vehicle-Object Simulation Model Program for Tractor Dynamics). Ph.D. thesis, North Carolina State University at Raleigh, 1980.
- 44) Song A., Huang B. K., Bowen H. D.: Simulating a Powered Wheel-Tractor on Soft Ground. Transactions of the ASAE 32(1): 2-11, 1989.
- 45) Feng Y. and Rehkugler G. E.: A Mathematical Model For Simulation of Tractor Sideways Overturns on Slopes. ASAE Paper No. 86-1063, 1986.
- 46) Spencer H. B. and Crolla D. A.: Control of Tractors on Sloping Ground. Proceedings 8th International Conference ISTVS, 1984.
- 47) Machida T.: The Fundamental Study of Hillside Tractor (1). The effect of the warming-up process and the friction characteristic of the rubber tyre under the sloped condition, Journal of the Japanese Society of Agricultural Machinery, 47(3): 285-292, 1985 (In Japanese).
- 48) Machida T.: The Fundamental Study of Hillside Tractor (2). Studies on the lateral drift of rubber tyres, Journal of the Japanese Society of Agricultural Machinery, 49(4): 329-337, 1987 (In Japanese).
- 49) Noh K. M. and Erback D. C.: A Semi-Recursive Dynamic Algorithm Using Variational Vector Approach. Transactions of ASAE. 34(4): 1566-1574, 1991.
- 50) Grecenko, A.: Predicting the Performance of Wheel Tractors in Combination with Implements. Journal of Agricultural Engineering Research 13(1): 49-63, 1968.
- 51) Schlegel J. E. and Morning R. W.: Optimum Travel Speed for Maximum Ploughing Acreage, Transactions of ASAE 12, 690, 1969.
- 52) Zoz, F. M.: Predicting Tractor Field Performance, Transactions of ASAE 15(2): 249-255, 1974.
- 53) Same as 13)

- 54) Freitag, D. R.: A Dimensional Analysis of the Performance of Pneumatic Tyres on Soft Soils. Technical Rept. 3-688. U. S. Army Engineer Waterways Experiment Station, 1965.
- 55) Turnage, G. W.: Tyre Selection and Performance Prediction for Off-road Wheeled Vehicle Operations. Proc. 4th Int. Conf. International Society for Terrain-Vehicle Systems, Stockholm, Sweden, 1972.
- 56) Kolozsi, Z. and MaCarthy, T. T.: The Prediction of Tractor Field Performance. *Journal of Agricultural Engineering Research* 19: 167-172, 1974.
- 57) Smith D. W. and Yoerger R. R.: Variations in the Forward Motion of Farm Tractors. *Transactions of ASAE*. 18(3): 401-403 and 408, 1975.
- 58) Gee-Clough D., McAllister M., Pearson G. and Everden D.: The Empirical Prediction of Tractor-Implement Field Performance. *Journal of Terramechanics* 15 (2): 81-94, 1978.
- 59) Yasuo Yoshimura, Tokuro Abe, Kanji Otsuka: Method of Drawing Climbing Tractive Performance Chart of a Wheel Tractor Based on Ground-to Tyre Coefficients, *Journal of the Japanese Society of Agricultural Machinery*, 43(2): 165-172 (In Japanese).
- 60) Summers, J. D., Ekstron, R. E. and Von Bargen, K.: Development of a Tractor Performance Simulation Model. *Transactions of ASAE* 29(3): 661-666, 1986.
- 61) de Souza, E. G., Milanez, L. F.: Prediction of Tractor Performance on Concrete. *Transactions of ASAE* 34(3): 727-732, 1991.
- 62) Isao Tajiri, Kunio Sato, Osamu Kitani: Research on Attitude Control of Tractors for Sloping ground (Part 1). A Machine Manufactured for Trial and its Behavior, *Journal of the Japanese Society of Agricultural Machinery*, 50(6): 35-44, 1988 (In Japanese).
- 63) Isao Tajiri, Kunio Sato: Research on Attitude Control of Tractors for Sloping ground (Part 2). Characteristics of Parallel Links for Front Wheels and Ground Load, *Journal of the Japanese Society of Agricultural Machinery*, 51(2): 57-65, 1989 (In Japanese).
- 64) Isao Tajiri, Kunio Sato: Research on Attitude Control of Tractors for Sloping ground (Part 1). Response Characteristics of Servo Valve Sensor with Acceleration Input, *Journal of the Japanese Society of Agricultural Machinery*, 54(5): 9-17, 1992 (In Japanese)
- 65) Gilfillan G.: Tractor Behaviour during Motion Uphill, I. Factors Affecting Behaviour, *Journal of Agricultural Engineering Research* 15(3): 221-235, 1970.
- 66) Gilfillan G.: Tractor Behaviour during Motion Uphill, II. Comparisons of Behaviour, *Journal of Agricultural Engineering Research* 15(3): 236-243, 1970.
- 67) Spencer H. B.: Stability and Control of Two-wheel Drive Tractors and Machinery on Sloping Ground. *J. agric. Engng Res.* (1978)23, 311-320.
- 68) Daskalov, A.: On the Dynamic Stability of Tractor Against Overturning. NIAE Translation No 330. National Institute of Agricultural Engineering. Silsoe, Bedfordshire, England, 1971.
- 69) Reichmann, E.: Hangstabilitat, landwirtschaftlicher Fahrzeuge, *Forschungsberichte der Bundesversuchs und Prufungsanstalt fur landwirtschaftliche Maschinen und Gerate*. Wieselburg, Austria, 1972.
- 70) Habarta F.: Determination in Relation to Safety of Operation of the Minimal Load on the Front Steering Axle of a Tractor with Implements Attached. *J. agric. Engng Res.* 16(2): 126-140, 1971.
- 71) Hudson T. C., Diener R. G. and Dubbe E. C.: Development of Simplified Equations for Simulation of Tractor Response to Dynamic Trailing Loads. *Transactions of ASAE*. 16(5): 862-866, 1973.
- 72) Same as 1)
- 73) Hunter A. G. M.: Some Stability and Control Problems with Trailed Farm Tankers on

- Slopes. Proceedings International Conference ISTVS, 1984
- 74) Hunter A. G. M. and Owen G. M.: Tractor Overturning Accidents on Slopes. *Journal of Occupational Accidents*. Elsevier Science Publishers B. V., Amsterdam, 5: 195-210, 1985.
 - 75) Wray G., Nazalewicz J. and Kwitowski A. J.: Stability Indicators for Front End Loaders. Proceedings of the 8th International Conference, International Society for Terrain Vehicle Systems. Cambridge, UK, 1984.
 - 76) Hunter A. G. M.: Stability Analysis of Trailed Tankers on Slopes. *J. agric Engng Res.* 32: 311-320, 1985.
 - 77) Sakai k., Terao H. and Nambu S.: The Dynamic Behavior of a Tractor-Vibrating Subsoiler System and the Effect of Virtual Hitch Point. Proceedings ISTVS Vol. II., 1987.
 - 78) Sakai K., Toyokawa Y., Nambu S., Mizushima S., Takai M. and Hata S.: Non-Linear Dynamics and Chaos in Agricultural Vehicle System. International Society for Terrain Vehicle Systems. Proceedings of the 4th Regional North American Meeting Sacramento, CA, March 25-27, 1992.
 - 79) Zhen-an L.: Investigations on the Trajectories of Wheels in a Vehicle-Trailer Combination in the Turning Process. Proceedings ISTVS. Vol.II., 1987.
 - 80) Asoegwu S. A.: Braking Performance For Different Weight Ratios of Agricultural Tractor-Trailer Systems. Proceedings 10th International Conference of ISTVS, Kobe, Japan August 20-24, 1990.
 - 81) Xie. L., Claar P. W. and Smith R. J.: Computer-Oriented Analytical Dynamics Methodologies for Vehicle Simulation. Proceedings 10th International Conference of the ISTVS, Kobe, Japan, 1990.
 - 82) Materek D. Włodzimierz B. and Sadlo J.: Analiza Wlasciwosci Trakcyjnych Ciagnikow Eksploatowanych na Gorskich Uzytkach Zielonych. *Zeszyty Naukowe Akademii Rolniczej we Wroclawiu. Mechanizacja Rolnicza I Nr 183*, 1990.
 - 83) Sadlo J., Bialczyk W. and Materek D.: Ocena Ukkladow Hamulcowych Agregatow Przeznaczonych do Pracy w Warunkach Gorskich. *Zeszyty Naukowe Akademii Rolniczej we Wroclawiu. Mechanizacja Rolnicza I Nr 183*, 1990.
 - 84) Zhang S. and Terao H.: Study of the Dynamic Performance of Tractor-Trailer Combinations for Farm Use. *Memoirs of the Faculty of Agriculture, Hokkaido University 17(4)*, Sapporo, Japan, 1991.
 - 85) Schwanghart H.: Tractor Overturning and Testing of Safety Devices Against Overturning. *Landtechnik Forschung*.19(1): 1-5, 1971.(Translated by E. Harris).
 - 86) Davis D. C. and Rehkugler G. E.: Agricultural Wheel Tractor Overturns PartII; Mathematical Model Verification by Scale-Model. *Transactions of ASAE 17(3)*: 484-488 and 492,1974b
 - 87) Chisholm C. J.: Research Note. Analysis of Rigid Body Motion From Cine Film Measurements. *J. agric. Engng Res 24(4)*: 441-446, 1979.
 - 88) Lyasko M. I., Terzian V. A.: Evaluation of the Compaction Effect and Directional Stability of a Wheeled Tractor Operating on Hillsides. *Soil and Tillage Research 28(1)*: 37-49, 1993.