

[REVIEW]

Further exploration into the adaptive design of the arthropod “microbrain”: I. Sensory and memory-processing systems

Makoto Mizunami^{1*}, Fumio Yokohari² and Masakazu Takahata³

¹Graduate School of Life Sciences, Tohoku University, Katahira 2-1-1, Aoba-ku, Sendai 980-8577, Japan

²Department of Biology, Faculty of Science, Fukuoka University, Fukuoka 814-0180, Japan

³Division of Biological Sciences, Graduate School of Science, Hokkaido University, Sapporo 060-0810, Japan

ABSTRACT—Arthropods have small but sophisticated brains that have enabled them to adapt their behavior to a diverse range of environments. In this review, we first discuss some of general characteristics of the arthropod “microbrain” in comparison with the mammalian “megalobrain”. Then we discuss about recent progress in the study of sensory and memory-processing systems of the arthropod “microbrain”. Results of recent studies have shown that (1) insects have excellent capability for elemental and context-dependent forms of olfactory learning, (2) mushroom bodies, higher olfactory and associative centers of arthropods, have much more elaborated internal structures than previously thought, (3) many genes involved in the formation of basic brain structures are common among arthropods and vertebrates, suggesting that common ancestors of arthropods and vertebrates already had organized head ganglia, and (4) the basic organization of sensori-motor pathways of the insect brain has features common to that of the mammalian brain. These findings provide a starting point for the study of brain mechanisms of elaborated behaviors of arthropods, many of which remain unexplored.

Key words: arthropod, antennal lobe, mushroom body, learning, brain evolution

INTRODUCTION

Arthropods are the most diverse and abundant animal group, representing about 80% of all known animal species (Brusca and Brusca, 1990), and they play a vital role in the Earth's ecosystem. These animals have successfully adapted themselves to virtually every habitat and have developed amazingly diverse forms of behavior. The enormous evolutionary success of arthropods in terms of species richness and diversity depends, at least in part, on the sophistication of their brains. We have suggested that many characteristic features of the arthropod “microbrain” compared with the mammalian “megalobrain” can be ascribed not only to the smaller number of its constituting neurons but also to the optimization to life with a smaller body (Mizunami *et al.*, 1999).

Recently, a research project aimed at revealing adaptive designs of the arthropod “microbrain” was performed in

Japan. The project focused on two subjects, sensory and memory-processing systems in the head ganglia, i.e., the “microbrain” proper, and the distributed processing in the whole central nervous system, including thoracic and abdominal ganglia. Here we review some of the recent progress in the understanding of sensory and memory-processing systems in the arthropod “microbrain”, focusing on the accomplishments of the “microbrain” research project. First, we briefly discuss functional characteristics of the arthropod “microbrain” in comparison with the mammalian “megalobrain”, and then we proceed to results of experimental studies.

Characteristic features of the arthropod “microbrain” in comparison with the mammalian “megalobrain”

Proposed functional characteristics of the arthropod “microbrain” in comparison with those of the mammalian “megalobrain” are shown in Table 1. These proposed functional characteristics are based mainly on the assumption that the arthropod “microbrain” is optimized to support life style and behavior of relatively small and short-lived animals

* Corresponding author: Tel. +81-22-217-5050;

Fax. +81-22-217-5050.

E-mail: makoto@biology.tohoku.ac.jp

Table 1. Some possible correlates of the microbrain and the megalobrain

	Microbrain	Megalobrain
<i>Animals</i>		
Representative animals	Arthropods	Mammals
Species diversity	Extremely high ($\sim 10^6$)	Moderate ($\sim 5 \times 10^4$)
Body size	Small (\sim mm, \sim cm)	Large (\sim m)
Length of life	Short (usually <1 year)	Long (usually > 1 year)
r - or K-selected ¹	K-selected	r-selected
<i>General features</i>		
Number of neurons	Small ($10^5 \sim 10^6$)	Large ($10^9 \sim 10^{11}$)
Functional units	Singly identifiable neuron ²	Neural population (layer, column)
Redundancy	Low	High
Priority in information processing	Speed, economy	Precision, flexibility
Degree of centralization	Less (more distributed)	More
Hierarchy in sensory or motor systems	Shallow	Deep
<i>Sensory systems</i>		
Function	Feature detection by a small number of "matched filters" ³	Formation of sensory map
Priority in vision	Motion vision	Form vision
Spatial resolution	Low (to perceive near objects) ⁴	High (to perceive remote objects)
<i>Memory systems</i>		
Importance of learning	Low ⁵	High
Information storage	Particular synapses in a particular sensori-motor pathway are modified	Neural circuits for general memory storage are equipped
Cognitive function	Elemental ⁶	Advanced
<i>Motor systems</i>		
Basic function	To control rapid movement of light-weight body	To control precise movement of heavy body
Motor signals	Specific commands by single neuron or a small number of neurons	Vectors formed by a population of neurons
Adaptive changes of motor programs	Switching among a small number of relatively stereotyped motor programs	Flexible changes of motor programs

¹ Pianka (1970).² An important exception is the mushroom body, where signals appear to be coded by an ensemble of neurons.³ Wehner (1987).⁴ Kirshfeld (1976).⁵ This differs in different behavioral tasks, as argued by Myer (1974).⁶ Some elemental cognitive capabilities of insects have been discussed by Giurfa (2003).

(relatively r-selected animals; Pianka, 1974), while the mammalian "megalobrain" is optimized for the life of large and long-lived animals (relatively K-selected animals), as discussed by Mizunami *et al.* (1999). For example, it is thought that (1) a singly identifiable neuron or a small number of neurons often serve as a functional unit for information processing in the arthropod "microbrain", while a large number of neurons that comprise a column or layer serve as a functional unit in the mammalian "megalobrain", (2) the hierarchies in sensory and motor systems are much shallower in the "microbrain" than in the "megalobrain", (3) a major objective of visual processing in arthropods is extraction of a rel-

atively small number of biologically significant features (Wehner 1987), while that in mammals is formation of map-like representations of the external sensory features, (4) motion vision is important for small and fast-moving animals, while discrimination of detailed features of targets by utilizing large number of neurons is achieved in large brains, (5) learning capability is less important for short-lived animals, including many arthropods, than for long-lived animals, including many mammals (Mayr, 1974), (6) information storage in small brains is often achieved by modifying particular synapses in particular sensorimotor pathways, while mammalian brains are equipped with neural circuits for general

memory storage, (7) priority in motor control for small and light-weight animals is the achievement of rapid movement, while that for large and heavy animals is the achievement of precise movement and (8) adaptive changes in motor programs in small brains may be achieved by switching among a small number of relatively stereotyped motor programs, while more flexible changes in motor programs are achieved in large brains. Although the validity of each item in Table 1 needs to be confirmed in future experimental studies, the proposed functional characteristics summarized in Table 1 should provide a starting point to elucidate adaptive design of the arthropod "microbrain".

On account of distinct features of the arthropod "micro-brain" from the mammalian "megalobrain" as shown in Table 1, it is becoming evident that many features of behavior and the brain are common among arthropods and mammals. For example, recent studies have shown that many short-lived arthropods exhibit excellent learning capability, especially in the context of foraging behavior, as is discussed in the next section. Mayr (1974) argued that social or communicative behavior (e.g., mating) of animals tends to be relatively inflexible so as to insure unambiguous communication, while resource-directed behavior (e.g., foraging) is more likely to be flexible because the environment is variable. This argument explains why even relatively short-lived animals exhibit well-developed learning capability in the context of resource-directed behavior.

Olfactory discrimination and learning

Most previous studies on olfactory learning and memory in arthropods were carried out on only two species, i.e., the honey bee (Menzel, 1999; Giurfa, 2003) and the fruitfly *Drosophila* (Dubnau and Tully, 2001; Heisenberg, 2003; Isabel *et al.*, 2004). Mizunami and colleagues examined whether cockroaches and crickets, known as excellent materials for electrophysiological studies of brain neurons (Staudacher and Schildberger, 1998; Mizunami *et al.*, 1998b; Okada *et al.*, 1999; Nishino *et al.*, 2003), are suitable for the study of olfactory learning and memory.

Olfactory learning capabilities of the cockroach *Periplaneta americana* and the cricket *Gryllus bimaculatus* were demonstrated in studies using operant (Matsumoto and Mizunami, 2000; Sakura and Mizunami, 2001) and classical (Matsumoto and Mizunami, 2002a; Watanabe *et al.*, 2003) conditioning paradigms. In both species, the preference for the odor associated with reward significantly increased after only one training session in both classical and operant conditioning paradigms. Memory formed by three training sessions lasted at least four weeks after training. In cockroaches, the classical conditioning procedure was effective even when they were harnessed in plastic tubes. Thus, this procedure may be useful for future electrophysiological studies of activity changes in brain neurons associated with olfactory learning.

By using an operant conditioning paradigm, Sakura *et al.* (2002) studied the capability of the cockroach to discrim-

inate (1) three normal aliphatic alcohols with different numbers of carbon (1-pentanol, 1-hexanol and 1-octanol), (2) three C6 aliphatic alcohols (1-hexanol, 2-hexanol and trans-2-hexen-1-ol), (3) binary mixtures of two of these three alcohols and their components and (4) 1-hexanol solution of three different concentrations. In all of these tests, cockroaches exhibited higher preferences for the odors associated with reward. It was concluded that cockroaches can discriminate odors of structurally similar alcohols nearly as well as humans, even though their olfactory system consists of a much smaller number of neurons than that in humans.

Matsumoto and Mizunami (2002a) studied temporal determinants of olfactory long-term memory retention in the cricket using a differential conditioning procedure in which one odor was associated with reward and another odor was associated with punishment. It was shown that (1) four conditioning trials are sufficient to lead to a saturated level of acquisition, (2) conditioning is successful when the conditioned stimulus is presented immediately or at 5 sec before the onset of presentation of the unconditioned stimulus and (3) the optimal interval between trials are 2–5 min. The formation of long-term olfactory memory (>5 hr) in crickets required *de novo* protein synthesis, while the formation of the short-term memory (<4 hr) did not (Matsumoto *et al.*, 2003).

Matsumoto and Mizunami (2002b) trained third- or

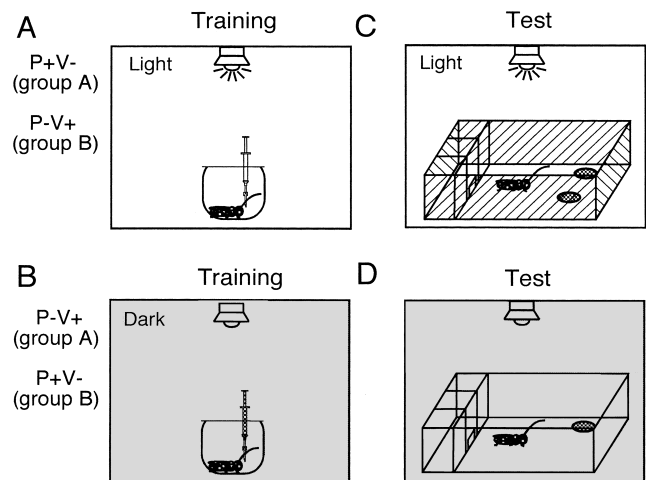

Fig. 1. Simplified diagrams of the experimental setup for context-dependent olfactory conditioning in crickets. Crickets were subjected to training or testing in the light or dark conditions. For training (A and B), each cricket was presented with peppermint or vanilla odor before the presentation of water (reward) or saline (non-reward) in a beaker. For the odor preference test (C and D), each cricket was allowed to freely choose between peppermint and vanilla sources in a box. For training or testing under illumination (A and C), a white fluorescent lamp on the ceiling was turned on. Group A crickets received training to associate peppermint odor with water and vanilla odor with saline solution (P+ and V- conditioning trials) under illumination and to associate vanilla odor with water and peppermint odor with saline solution (P- and V+ conditioning trials) in the dark. Group B crickets received training of the opposite stimulus arrangement. Modified from Matsumoto and Mizunami (2004).

fourth-instar nymph crickets to associate one odor with water and another odor with saline solution. At six and ten weeks after training, adult crickets exhibited significantly greater preferences for the odor associated with water over that associated with saline solution. It was therefore concluded that crickets are capable of retaining olfactory memory for practically their entire lifetime.

Matsumoto and Mizunami (2004) found that cricket had a capability for context-dependent olfactory learning. One group of crickets was trained to associate one of a pair of odors (conditioned stimulus, CS1) with water reward (appetitive unconditioned stimulus, US+) and another odor (CS2) with saline solution (aversive US, US-) under illumination and to associate CS1 with US- and CS2 with US+ in the dark (Fig. 1). Another group of crickets received training of the opposite stimulus arrangement. One day after the training for three days, the former group significantly preferred CS1 over CS2 under illumination but preferred CS2 over CS1 in the dark, and the latter group exhibited the opposite odor preference.

In honey bees, Ichikawa and Sasaki (2003) demonstrated the importance of social stimuli for the development of learning capability. Newly emerged and very young worker bees could not associate a given odor (CS) with a sucrose reward (US). When workers are reared individually in a confined condition and deprived of colony odor and other social stimuli, they do not develop the ability even after 9 days after emergence. The important period for acquiring the learning ability was found to be from day 2 to day 6 after emergence.

Information processing in the antennal lobe

In insects, olfactory information is relayed from olfactory receptor neurons in the antennae to the antennal lobe (AL) and then to two areas of the protocerebral neuropils, i.e., the lateral protocerebrum (the lateral horn) and the mushroom body (MB) (Hildebrand and Shepherd, 1997). In the AL, the receptor neurons make synaptic connections with postsynaptic neurons in specialized compartments called glomeruli. In many species, the AL of the male comprises a number of ordinary glomeruli and a sexually dimorphic glomerulus called the macroglomerular complex (MGC), the latter receiving axon terminals of receptor neurons of sex-pheromones.

Kanzaki and colleagues revealed some aspects of functional organization of the antennal lobe of the silkworm. The MGC of the male silkworm consists of three subdivisions: the cumulus, toroid and horseshoe. Intracellular recording and staining revealed that responses of MGC projection neurons to pheromonal stimulation correlate with their dendritic arborizations in the subdivisions of the MGC and that each subdivision-specific projection neuron transmits information to different regions in the calyces of the MB and the inferior lateral protocerebrum (Kanzaki *et al.*, 2003). Major pheromone component information is transferred to the medial part of the inferior lateral protocerebrum. Thus, this part may

be an important processing site for major pheromonal information.

Hill *et al.* (2002) found a serotonin-immunoreactive neuron in the brain of the male silkworm *Bombyx mori* that branched in many important brain neuropils such as the MB, central body, lateral accessory lobe and AL (Fig. 2). The neuron responded to mechanosensory stimuli to the antennae. In order to examine the possible modulatory effects of serotonin in the AL, Hill *et al.* (2003) utilized optical imaging with a voltage-sensitive dye combined with bath application of serotonin. Serotonin caused increases in the optical responses in both the MGC and the ordinary glomeruli evoked by electrical stimulation of the antennal nerve. Serotonin exerted a significantly greater enhancing effect in the toroid glomerulus of the MGC than in the cumulus or horseshoe, and the effects of serotonin were also non-homogeneously distributed in the ordinary glomeruli.

Ai and Kanzaki (2004) studied the functional synaptic

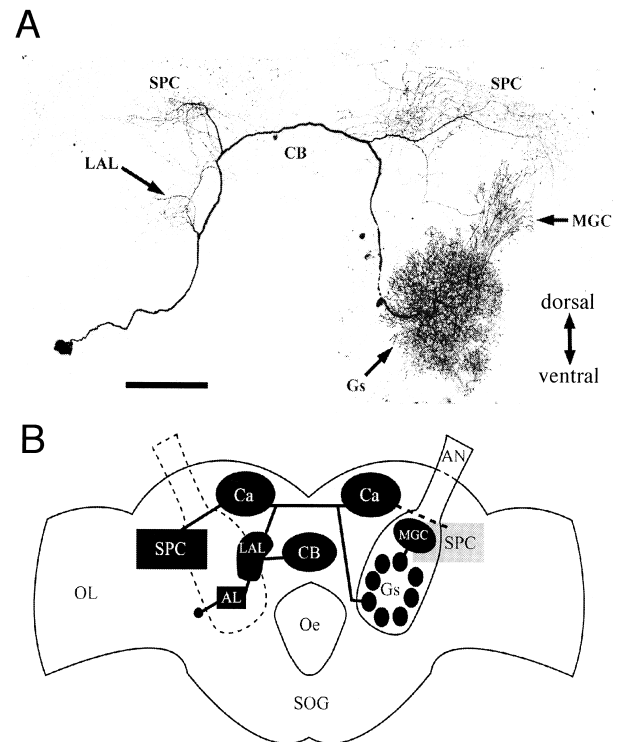

Fig. 2. Confocal image of the brain of the silkworm *Bombyx mori* (frontal view). (A) This neuron has its soma in the posterior portion of the lateral cell cluster of one AL. The primary neurite projects through the ipsilateral AL, where it has a few fine branches in the posterior coarse neuropil. Branches are present in the ipsilateral lateral accessory lobe (LAL) and in both ipsi- and contralateral parts of the protocerebrum (PC), including the calyces (Ca) of both MBs, and also in the central body (CB). More extensive branching is seen in the contralateral superior PC. In the contralateral AL, branches are present in every ordinary glomeruli (Gs) as well as in each compartment of the macroglomerular complex (MGC). Scale bar: 100 μ m. D: dorsal, V: ventral. (B) Schematic diagram of the brain regions innervated by this neuron. Oe: oesophagus, OL: optic lobe, SOG: suboesophageal ganglion, SPC: superior protocerebrum. Modified from Hill *et al.* (2002).

organization of the MGC of the male silkworm by optical recording with a voltage-sensitive dye. Sensory neurons in the antennae send their axons down either the medial nerve or lateral nerve, depending on whether they are located on the medial or lateral flagella. Pheromone-sensitive fibers in the medial nerve are biased towards the medial MGC, and those in the lateral nerve are biased towards the lateral MGC in the AL. When the medial nerve was stimulated, the amplitudes of the excitatory postsynaptic activities in the central toroid, the medial toroid and the medial cumulus were higher than those in the other areas. In contrast, when the lateral nerve was stimulated, excitatory postsynaptic activities were evoked in areas in both the lateral toroid and the lateral cumulus. It was concluded that information from the two main branches of the antenna is segregated to different sub-regions of the MGC glomeruli.

Odor-induced oscillatory signals have been observed in olfactory neural networks of vertebrates and invertebrates and implicated in olfactory processing (Stopfer *et al.*, 1997). Okada and Kanzaki (2001) examined the localization of oscillatory signals in the AL using an optical recording technique with a voltage-sensitive dye in the bumblebee, and they found that the oscillatory signals were usually localized to regions corresponding to a single or several glomerular structures.

In the fruitfly *Drosophila melanogaster*, mate choice during courtship depends on detection of sex pheromones, which are initially processed in the AL, but no sexually-dimorphic glomeruli have been found in the AL. Kondo *et al.* (2003) compared the brain anatomies of 37 species of Drosophilidae from the islands of the Hawaiian archipelago, uncovering a sexual dimorphism within the AL in which two out of the 51 identifiable glomeruli were markedly enlarged in males. A phylogeny indicated that the sexual dimorphism of the homologous glomeruli arose independently in two species groups of Hawaiian endemic Drosophilidae. The corresponding glomeruli in *D. melanogaster* were also found to be sexually dimorphic. The formation of glomeruli of male size is prevented by the ectopic expression of female-type *transformer (tra)* cDNA in males. A defined set of glomeruli in *Drosophila* may enlarge in response to sex-determination genetic signals, mutations of which may result in species differences in sexual dimorphism of the brain.

Much progress has been attained to identify olfactory receptor genes in *Drosophila* (Vosshall *et al.*, 2000) and to characterize odor coding in the primary olfactory center (the antennal lobe) in *Drosophila* (Keller and Vosshall, 2003; Wang *et al.*, 2003), honeybees (Sachse and Galizia, 2003), moths (Daly *et al.*, 2004) and locusts (Stopfer *et al.*, 2003). The results provide solid basis for future studies of odor processing at a more central level.

Structure, development and gene expression in the mushroom body

MBs are higher olfactory and multisensory centers of the arthropod brain (Strausfeld *et al.*, 1998) and implicated

in odor discrimination (Laurent, 2002) and in olfactory and other forms of associative learning (Erber *et al.*, 1980; Davis, 1996; Mizunami *et al.*, 1998c; Giurfa, 2003; Heisenberg, 2003).

Yasuyama *et al.* (2002) investigated the synaptic circuits of the calyx (a major input neuropil) of the MB in the fruitfly using immuno-electron microscopy. The calyx neuropil contained (1) extrinsic neurons with immunoreactivity to choline acetyltransferase that correspond to projection neurons from the AL, (2) extrinsic neurons with GABA-like immunoreactivity that arise from the protocerebrum, and (3) intrinsic neurons of the MB called Kenyon cells. It was shown that Kenyon cells may receive major excitatory input from cholinergic boutons and considerable postsynaptic inhibition from GABAergic terminals as well as, more rarely, presynaptic inhibitory signaling.

The pedunculus and lobes of the cockroach MB consist of 15 repetitive modular subunits, each consisting of a light slab and a dark slab (Mizunami *et al.* 1997, 1998). Iwasaki *et al.* (1999) compared the ultrastructures of the light and the dark slabs in the pedunculus of the cockroach. Quantitative analyses of transversely sectioned Kenyon cell axons showed that average diameters of Kenyon cell axons in the light slabs were 5–18% larger than those in adjacent dark slabs, the difference being statistically significant. The results suggest that diameter of Kenyon cell axons is one of major factors contributing to the varied density of slabs. Varied conduction velocity due to different axon diameter may be utilized for signal processing.

In mammals, the *Pax6* gene is expressed in various regions of the forebrain and is important for olfactory memory processing and emotional learning (Stoykova and Gruss, 1994). Kurusu *et al.* (2000) showed that *Pax6* homologs *eyeless (ey)*, *twinn of eyeless* and *dachshund (dac)* are expressed in the developing MBs of the fruitfly *Drosophila*. Mutations of *ey* completely disrupted the MB neuropils, and a null mutation of *dac* resulted in marked disruption and aberrant axonal projections. Genetic analyses demonstrated that, whereas *ey* and *dac* synergistically control the structural development of the MBs, the two genes are regulated independently in the course of MB development. These findings suggest conserved roles of *Pax6* homologs in the genetic programs of the olfactory learning centers.

Kurusu *et al.* (2002) also studied the embryonic development and post-embryonic development of the fruitfly MBs. In the mid to late embryonic stages, the pioneer MB tracts extend along Fasciclin II (FAS II)-expressing cells to form the primordia for the peduncle and the medial lobe. As development proceeds, the axonal projections of the larval MBs are organized in layers surrounding a characteristic core, which harbors bundles of actin filaments (Fig. 3). Mosaic analyses revealed sequential generation of the MB layers, in which newly produced Kenyon cells project into the core to shift to more distal layers as they undergo further differentiation. Whereas the initial extension of the embryonic MB tracts is intact, loss-of-function mutations of *fas II*

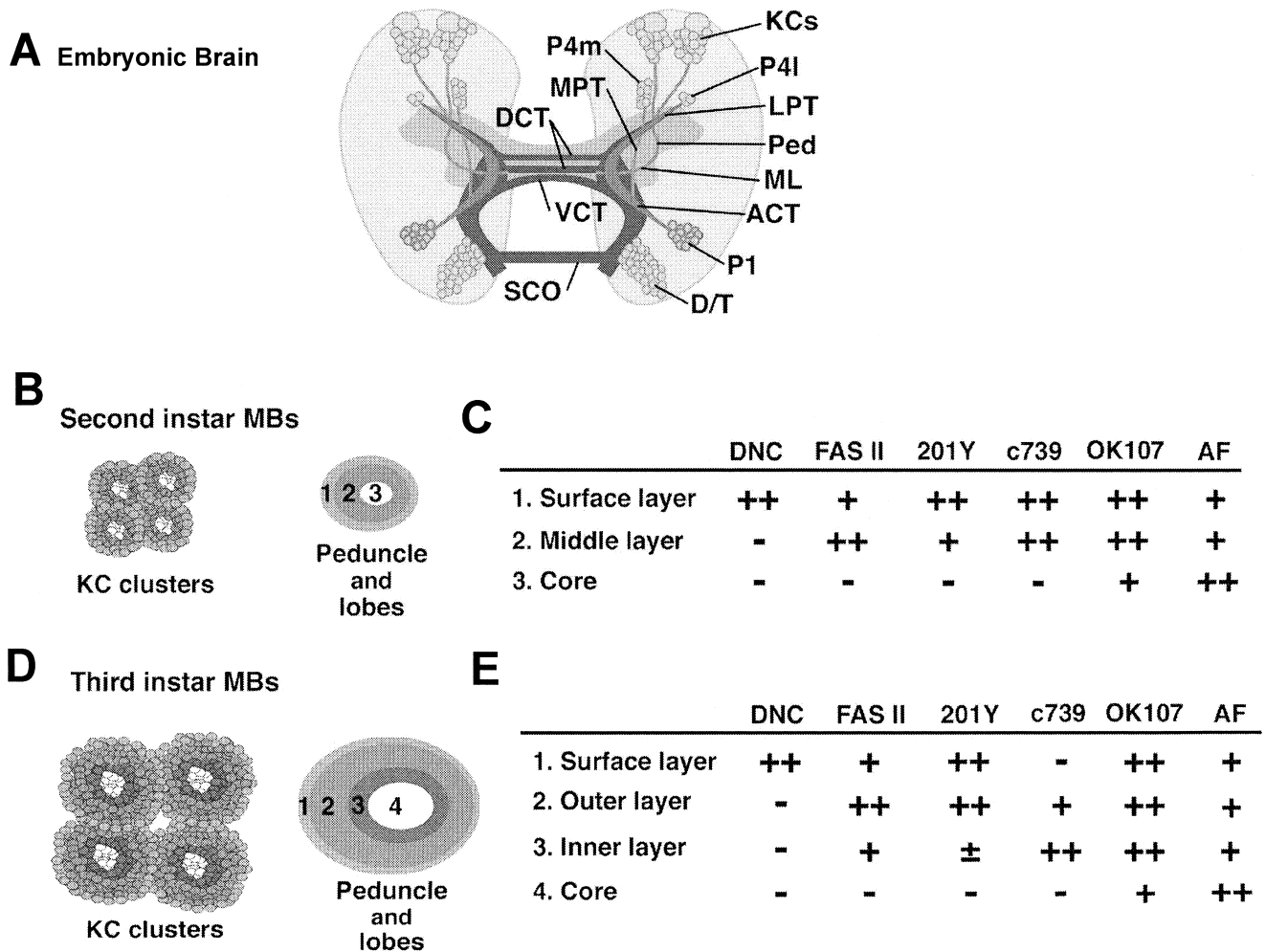

Fig. 3. (A) The MB primordia in the embryonic brain. Frontal view of the embryonic brain at late stage 16. (B,C) Layer organization of the second and third instar larval MBs. Dorsal images of Kenyon cell clusters and cross sections of the peduncle and lobes. Corresponding subdivisions are shown in the same lightness. Relative expression levels of various MB markers are summarized in the table. The second instar MBs can be concentrically subdivided in two layers surrounding the core. With increase in the numbers of Kenyon cells and their projections, the third instar MBs can be subdivided into three layers surrounding the core. Note that the distoproximal concentric subdivisions of each of the four Kenyon cell clusters topologically correspond to the unified concentric subdivisions in the lobes and the peduncle. The core consists of a bundle of newly formed axon fibers that contain densely packed actin filaments. AF, actin filaments; ACT, antennocerebral tract; DCT, dorsal commissural tract; DNC, *dnc-lacZ*; KCs, Kenyon cells; LPT, lateral protocerebral tract; MPT, medial protocerebral tract; P1, P4l, P4m, and D/T, fiber tract founder clusters; Ped, peduncle; VCT, ventral commissural tract. Modified from Kurusu *et al.* (2002).

cause abnormal formation of the larval lobes. Mosaic studies demonstrated that FAS II is intrinsically required for the formation of the coherent organization of the internal MB fascicles.

A detailed comparison of the development of the MB of cockroaches (Farris and Strausfeld, 2001), *Drosophila* (Strausfeld, *et al.*, 2003), and honeybees (Farris *et al.*, 2004) revealed unexpected similarities among species, including the emergence of class II (clawed) Kenyon cells in an early stage of development.

Several genes that are expressed in the MB of the honey bee have been characterized by Kubo and colleagues. One such gene is *Mblk-1*, which is expressed preferentially in large Kenyon cells of the MB, encodes a putative transcription factor with two DNA-binding motifs, and

might function downstream of the Ras/MAPK pathway (Takeuchi *et al.*, 2001; Park *et al.*, 2002, 2003).

Fujiyuki *et al.* (2004) identified a candidate gene involved in the aggressive behavior of worker honey bees. They used the differential display method to search for RNAs exclusively detected in the brains of aggressive workers that had attacked a hornet, and they identified a novel RNA, termed Kakugo RNA. It is a plus-strand RNA of a novel picorna-like virus, and the brains of aggressive workers were found to be infected by this novel virus. Kakugo RNA was detected in aggressive workers but not in nurse bees or foragers. In aggressive workers, Kakugo RNA was detected in the brain but not in the thorax or abdomen, suggesting a close relation between viral infection in the brain and aggressive worker behavior.

In order to explore how olfactory information is processed in the brain and finally converted into behavior, it is useful to establish an isolated whole brain preparation that includes both olfactory organs and motor output. This was accomplished using the terrestrial mollusk *Limax* by Inoue *et al.* (2004). They identified an *in vitro* index of odor-evoked behavior in the *Limax* and determined that shortening of the mantle muscles is one of the withdrawal responses selectively induced by aversive odors and that the shortening is mediated by a pair of parietal nerves. They also identified a motoneuron that innervates the mantle muscles. When they applied various odors to the nose in these isolated molluscan brains, only aversive odors induced discharges in this motoneuron. These results indicate that the discharges of the motoneuron can serve as an *in vitro* index of odor-induced aversive behavior.

Possible common origin of arthropod microbrain and vertebrate megalobrain

The molecular mechanisms of head development are a central question in vertebrate and invertebrate developmental biology. The anteriorly expressed homeobox gene *otd* in *Drosophila* and its homolog *Otx* in the mouse are required for early development of the most-anterior part of the body, suggesting that a fundamental genetic program of cephalic

development might be conserved between vertebrates and invertebrates (Hirth *et al.*, 1995). This hypothesis was examined by introducing human *Otx* genes into flies (Nagao *et al.*, 1998). By inducing expression of human *Otx* homologs with a heat shock promoter, they found that both *Otx1* and *Otx2* functionally complement the cephalic defects of a fly *otd* mutant through specific activation and inactivation of downstream genes. The results are consistent with the view that a common molecular ground plan of cephalization was invented before the diversification of the protostome (that includes arthropods) and the deuterostome (that includes vertebrates) in the course of metazoan evolution.

Another way to address the question of whether the central nervous system (CNS) was derived from a common ancestor of deuterostomes and protostomes is to identify genes in the CNS of the putative common ancestor and to trace the evolutionary divergence of genes expressed in the CNS. Mineta *et al.* (2003) took a comparative approach using different species, focusing on one of the lower bilateral animals, the planarian, which is known to possess a CNS. They determined the nucleotide sequence of ESTs from the head portion of planarians, and, as a result of homology searches, they found that 116 clones had significant similarity to known genes related to the nervous system. They

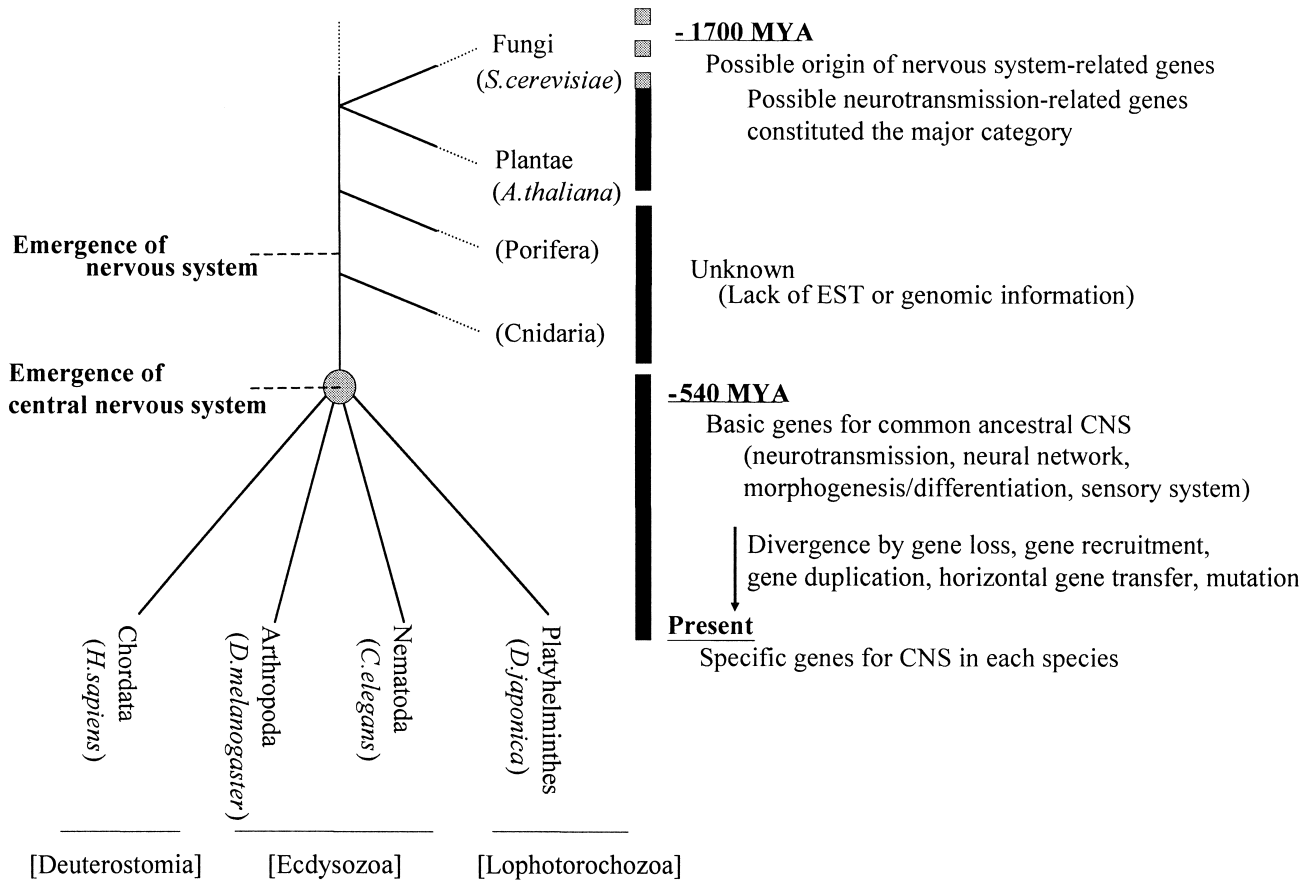

Fig. 4. A possible scenario of the process of evolution of the CNS. The phyla not analyzed are indicated in parenthesis. Possible events during evolution of the NS-related genes are noted. Modified from Mineta *et al.* (2003).

compared these 116 planarian EST clones with all open reading frames of the complete genome sequences of the human, fruitfly, and nematode and showed that >95% of these 116 nervous system-related genes, including genes involved in brain or neural morphogenesis, were commonly shared among these organisms, thus providing evidence at the molecular level for the existence of a common ancestral CNS (Fig. 4). This implies that the origin of nervous system-related genes greatly predated the emergence of the nervous system.

Basic organization of the arthropod microbrain

Elucidation of the basic organization of sensorimotor pathways in the arthropod brain was hampered by the lack of precise knowledge about the brain areas from which descending neurons originate to supply thoracic locomotory centers. Okada *et al.* (2003) examined the distribution of dendrites of descending neurons in the cockroach brain by retrogradely filling their axons from the cervical connective. The dendrites of descending neurons were found to be distributed in most brain areas, including lateral and medial

protocerebra, which are major termination areas of output neurons of the MB, but not in the optic lobe, the AL, the MB, the central complex, or the postero-ventral part of the lateral horn. The last area is the termination area of major types of olfactory projection neurons from the AL, i.e., uni- and macrogglomerular projection neurons, and, thus, these neurons have no direct connections with descending neurons. Based on these findings, Okada *et al.* have proposed that there are numerous parallel processing streams from cephalic sensory areas to thoracic locomotory centers, many of which are via premotor brain areas from which descending neurons originate. In addition, output from the MB, central complex and postero-ventral part of the lateral horn converge on some of the premotor areas presumably to modulate the activity of some sensori-motor pathways (Fig. 5). They proposed that many parallel processing streams function in various forms of reflexive and relatively stereotyped behaviors, while indirect pathways govern some forms of experience-dependent modification of behavior. Notably, this organization has fundamental similarities to basic organizations of the mammalian brain: Parallel and hierarchical features of

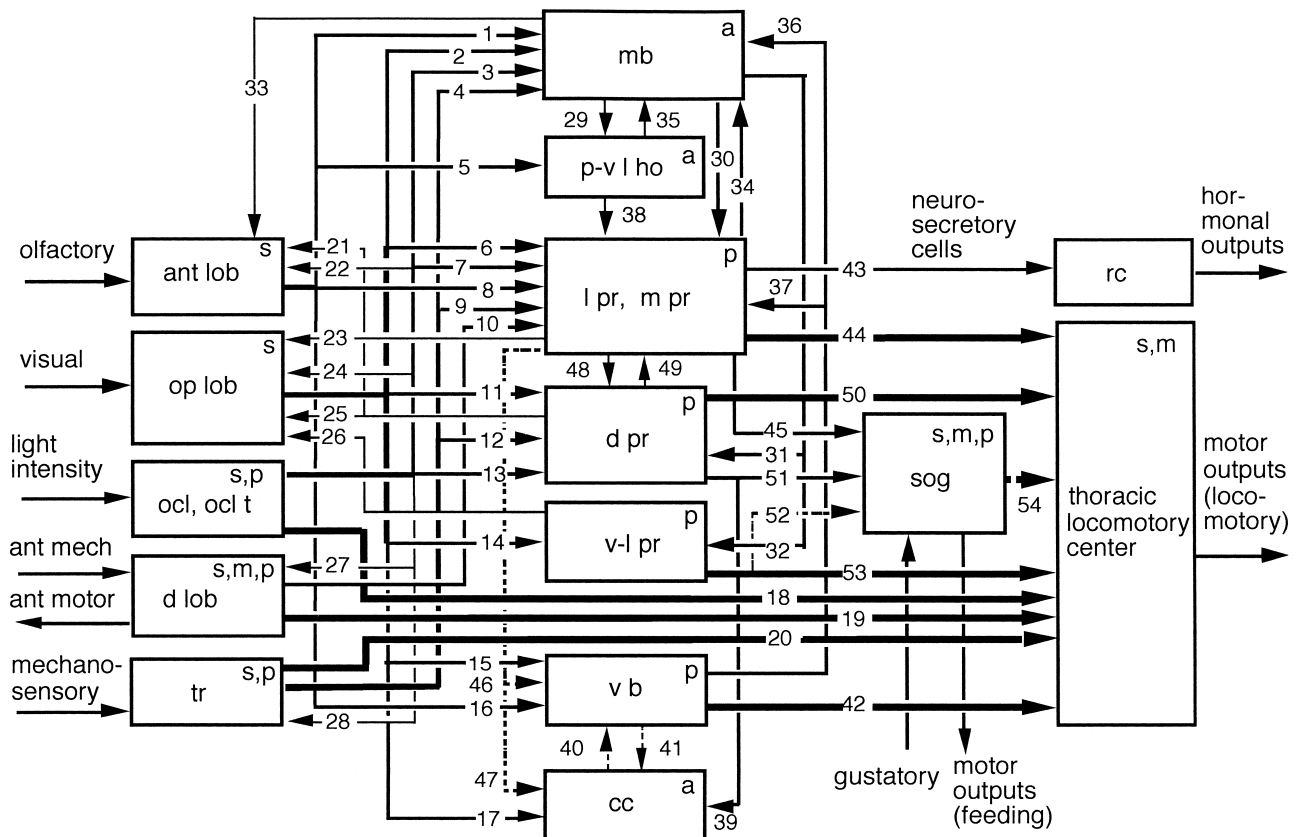

Fig. 5. A simplified diagram of neural pathways in the cockroach brain. Some neural pathways that have not yet been found in cockroaches but have been well established in other species of insects are also shown, by dashed lines, in order to better represent current knowledge on neural organizations of the insect brain. For simplification, descending pathways from the brain to the subesophageal ganglion (*sog*) and ascending pathways from the thoracic ganglia (*tg*) to the brain are not shown. Sensorimotor pathways in the *sog* and the *tg*, including proprioceptive sensory pathways, are also not shown. The *l pr* represents all of the *l pr* area except for the postero-ventral part of the lateral horn (*p-v l ho*). Brain neuropils are characterized as sensory (*s*), association (*a*), premotor (*p*) and motor (*m*) areas. The numbers indicate references described in Okada *et al.*, 2003. They are mostly confined to study using intracellular recording and staining techniques; dendritic and termination areas of the neurons are estimated from their morphology and from their neural activities. Modified from Okada *et al.* (2003).

sensorimotor pathways of the brains of vertebrates, including mammals, have been well documented (Romer and Persons, 1977; Brooks, 1986) and it has been suggested that the brains of mammals comprise amalgamating neural systems for reflexive behavior (brainstem), those for instinctive or emotional behavior (limbic system) and those for higher functions (neocortex) (MacLean, 1990). The similarities in the basic organization of the arthropod “microbrain” and mammalian “megalobrain” may reflect their common origin, if the suggestion from molecular and genetic studies that the common ancestors of vertebrates and invertebrates had more or less organized head ganglia is correct.

Other findings

Simple nervous systems of arthropods or other invertebrates are useful materials for the study of cellular and molecular mechanisms of basic brain functions. In studies using the fruitfly *Drosophila*, a sugar receptor gene was identified (Ueno *et al.*, 2001), receptor neurons of bitter tastes were characterized (Meunier *et al.*, 2003) and molecular mechanisms of synaptic growth during development were examined (Awasaki *et al.*, 2000; Ritzenthaler *et al.*, 2000; Sone *et al.*, 2000). In addition, in studies using the nematode *Caenorhabditis elegans*, the involvement of Ras/MAPK signaling in olfaction was demonstrated (Hirotsu *et al.*, 2000), and a secretory protein that regulates sensory integration and learning was identified (Ishihara *et al.*, 2002). Other notable findings from our research project include the first behavioral demonstration of color vision by spiders (Nakamura and Yamashita, 2000) and identification of a cerebral neuron that contributes to synaptic modulation during taste aversion learning in *Aplysia* (Narusuye and Nagahama, 2002).

Future perspectives

The finding that the basic organization of the arthropod “microbrain” has some fundamental similarities to that of the mammalian “megalobrain” suggests that the arthropod brain is a useful material for studying basic neural mechanisms of brain functions common among many phyla of animals, not only at the molecular and cellular levels but also at the level of neural circuits. Arthropod ‘microbrain’ consists of relatively small number of neurons and is advantageous for clarifying neural mechanisms of brain functions in terms of singly identifiable neurons.

Some species of arthropods exhibit unusually sophisticated behaviors and provide opportunities to elucidate neural basis of some of the most sophisticated functions of animal brains evolved through natural selection. Some of fascinating behavioral capabilities of arthropods include: dance communication (by honey bee foragers), skylight compass orientation, navigation on the basis of visual landmark memory, context-dependent olfactory learning and sophisticated communication by means of various kinds of pheromones. The accumulation of information on basic structure and functions of the arthropod brain as well as

newly emerging experimental techniques such as optical recording and RNA interference paves the way for proceeding into the study of elaborated brain functions of arthropods.

ACKNOWLEDGEMENTS

This work was supported by a Grant-in-Aid for Scientific Research on Priority Areas (#383) from the Ministry of Education, Science, Culture, Sports and Technology of Japan.

REFERENCES

- Ai H, Kanzaki R (2004) Modular organization of the silkworm antennal lobe macroglomerular complex revealed by voltage-sensitive dye imaging. *J Exp Biol* 207: 633–644
- Awasaki T, Saitoh M, Sone M, Suzuki E, Sakai R, Itoh K, Nabeshima Y-I, Hama C (2000) The *Drosophila* *TRIO* plays an essential role for patterning of axons by regulating their directional extension. *Neuron* 26: 119–132
- Brooks VB (1986) The neural basis of motor control. Oxford University Press, New York
- Brusca RC, Brusca GJ (1990) Invertebrates. Sinauer, Sunderland
- Daly KC, Christensen TA, Lei H, Smith B, Hildebrand JG (2004) Learning modulates the ensemble representations for odors in primary olfactory networks. *Proc Natl Acad Sci USA* 101: 10476–10481
- Davis RL (1996) Physiology and biochemistry of *Drosophila* learning mutants. *Physiol Rev* 76: 299–317
- Dubnau J, Tully T (2001) Functional anatomy: From molecule to memory. *Curr Biol* 11: R240–243
- Erber J, Masuhr T, Menzel R (1980) Localization of short-term memory in the brain of the bee, *Apis mellifera*. *Physiol Entomol* 5: 343–358
- Farris SM, Strausfeld NJ (2001) Development of laminar organization in the mushroom bodies of the cockroach: Kenyon cell proliferation, outgrowth, and maturation. *J Comp Neurol* 439: 331–351
- Farris SM, Abrams AI, Strausfeld NJ (2004) Development and morphology of class II Kenyon cells in the mushroom bodies of the honey bee, *Apis mellifera*. *J Comp Neurol* 474: 325–339
- Fujiyuki T, Takeuchi H, Ono M, Ohka S, Sasaki T, Nomoto A, Kubo T (2004) Novel insect picorna-like virus identified in the brains of aggressive worker honeybees. *J Virol* 78: 1093–1100
- Giurfa M (2003) Cognitive neuroethology: dissecting non-elemental learning in a honeybee brain. *Curr Opin Neurobiol* 13: 1–10
- Heisenberg M (2003) Mushroom body memoir: from maps to models. *Nat Rev Neurosci* 4: 266–275
- Hildebrand JG, Shepherd GM (1997) Mechanisms of olfactory discrimination: converging evidence for common principles across phyla. *Ann Rev Neurosci* 20: 595–631
- Hill ES, Iwano, Gatellier L, Kanzaki R (2002) Morphology and physiology of the serotonin-immunoreactive putative antennal lobe feedback neuron in the male silkworm *Bombyx mori*. *Chem Senses* 27: 475–483
- Hill ES, Okada K, Kanzaki R (2003) Visualization of modulatory effects of serotonin in the silkworm antennal lobe. *J Exp Biol* 206: 345–352
- Hirotsu T, Saeki S, Yamamoto M, Iino Y (2000) The Ras-MAPK pathway is important for olfaction in *C. elegans*. *Nature* 404: 289–293
- Hirth F, Therianos S, Loop T, Gehring W, Reichert H, Furukubo-Tokunaga K (1995) Developmental defects in brain segmentation caused by mutations of the homeobox gene *orthodenticle* and *empy spiracles* in *Drosophila*. *Neuron* 15: 769–778

- Ichikawa N, Sasaki M (2003) Importance of social stimuli for the development of learning capability in honeybees. *Appl Entomol Zool* 38: 203–209
- Inoue T, Inokuma Y, Watanabe S, Kirino Y (2004) In vitro study of odor-evoked behavior in a terrestrial mollusk. *J Neurophysiol* 91: 372–381
- Isabel G, Pascual A, Preat T (2004) Exclusive consolidated memory phases in *Drosophila*. *Science* 304: 1024–1027
- Ishihara T, Iino Y, Mohri A, Mori I, Gengyo-Ando K, Mitani S, Katsura I (2002) HEN-1, a secretory protein with an LDL receptor motif, regulates sensory integration and learning in *Caenorhabditis elegans*. *Cell* 109: 639–649
- Iwasaki M, Mizunami M, Nishikawa M, Itoh T, Tominaga Y (1999) Ultrastructural analysis of modular subunits in the mushroom bodies of the cockroach. *J Electron Microsc* 48: 55–62
- Kanzaki R, Soo K, Seki Y, Wada S (2003) Projections to higher olfactory centers from subdivisions of the antennal lobe macroglomerular complex of the male silkworm. *Chem Senses* 28: 113–130
- Keller A, Vosshall LB (2003) Decoding olfaction in *Drosophila*. *Curr Opin Neurobiol* 13: 103–110
- Kirshfeld K (1976) The resolution of lens and compound eye. In "Neural principles in vision" Ed by F Zettler, R Weiler, Springer, Berlin, pp 354–370
- Kondoh Y, Kaneshiro KY, Kimura K, Yamamoto D (2003) Evolution of sexual dimorphism in the olfactory brain of Hawaiian *Drosophila*. *Proc R Soc Lond B Biol Sci* 270: 1005–1013
- Kurusu M, Nagao T, Walldorf U, Flister S, Gehring WJ, Furukubo-Tokunaga K (2000) Genetic control of the development of the mushroom bodies, the associative learning centers in the *Drosophila* brain, by the *eyeless*, *twin of eyeless* and *dachshund* genes. *Proc Natl Acad Sci USA* 97: 2140–2144
- Kurusu M, Awasaki T, Masuda-Nakagawa LM, Kawauchi H, Ito K, Furukubo-Tokunaga K (2002) Embryonic and larval development of the *Drosophila* mushroom bodies: concentric layer subdivisions and the role of *fasciclin II*. *Development* 129: 409–419
- Laurent G (2002) Olfactory network dynamics and the coding of multidimensional signals. *Nature Neurosci* 3: 884–895
- MacLean P (1990) Triune brain in evolution. Plenum, New York
- Matsumoto Y, Mizunami M (2000) Olfactory learning in the cricket *Gryllus bimaculatus*. *J Exp Biol* 203: 2581–2588
- Matsumoto Y, Mizunami M (2002a) Temporal determinants of olfactory long-term retention in the cricket *Gryllus bimaculatus*. *J Exp Biol* 205: 1429–1437
- Matsumoto Y, Mizunami M (2002b) Lifetime olfactory memory in the cricket *Gryllus bimaculatus*. *J Comp Physiol A* 188: 295–299
- Matsumoto Y, Noji S, Mizunami M (2003) Time course of protein synthesis-dependent phase of olfactory memory in the cricket *Gryllus bimaculatus*. *Zool Sci* 20: 409–416
- Matsumoto Y, Mizunami M (2004) Context-dependent olfactory learning in an insect. *Learn Mem* 11: 288–293
- Mayr E (1974) Behavior programs and evolutionary strategies. *Am Sci* 62: 650–659
- Menzel R (1999) Memory dynamics in the honeybee. *J Comp Physiol A* 185: 323–340
- Mineta K, Nakazawa M, Cebria F, Ikeo K, Agata K, Gojobori T (2003) Origin and evolutionary process of the CNS elucidated by comparative genomics analysis of planarian ESTs. *Proc Natl Acad Sci USA* 100: 7666–7671
- Meunier N, Marion-Poll F, Rospars JP, Tanimura T (2003) Peripheral coding of bitter taste in *Drosophila*. *J Neurobiol* 56: 139–152
- Mizunami M, Iwasaki M, Nishikawa M, Okada R (1997) Modular structures in the mushroom body of the cockroach. *Neurosci Lett* 229: 153–156
- Mizunami M, Iwasaki M, Okada R, Nishikawa M (1998a) Topography of modular subunits in the mushroom bodies of the cockroach. *J Comp Neurol* 399: 153–161
- Mizunami M, Okada R, Li Y, Strausfeld NJ (1998b) Mushroom bodies of the cockroach: The activity and identities of neurons recorded in freely moving animals. *J Comp Neurol* 402: 501–519
- Mizunami M, Weibrecht JM, Strausfeld NJ (1998c) Mushroom bodies of the cockroach: their participation in place memory. *J Comp Neurol* 402: 520–537
- Mizunami M, Yokohari F, Takahata M (1999) Exploration into the adaptive design of the arthropod "microbrain." *Zool Sci* 16: 703–709
- Nagao T, Leuzinger S, Acampora D, Simeone A, Finkelstein R, Reichert H, Furukubo-Tokunaga K (1998) Developmental rescue of *Drosophila* cephalic defects by the human *Otx* genes. *Proc Natl Acad Sci USA* 95: 3737–3742
- Nakamura T, Yamashita S (2000) Learning and discrimination of colored papers in jumping spiders (Araneae, Salticidae). *J Comp Physiol A* 186: 897–901
- Narusuye K, Nagahama T (2002) Cerebral CBM1 neuron contributes to synaptic modulation appearing during rejection of seaweed in *Aplysia kurodai*. *J Neurophysiol* 88: 2778–2795
- Nishino H, Yamashita S, Yamazaki Y, Nishikawa M, Yokohari F, Mizunami M (2003) Projection neurons originating from thermo- and hygro-sensory glomeruli in the antennal lobe of the cockroach. *J Comp Neurol* 455: 40–55
- Okada K, Kanzaki R (2001) Localization of odor-induced oscillations in the bumblebee antennal lobe. *Neurosci Lett* 316: 133–136
- Okada R, Sakura M, Mizunami M (2003) Distribution of dendrites of descending neurons and its implications for the basic organization of the cockroach brain. *J Comp Neurol* 458: 158–174
- Okada R, Ikeda J, Mizunami M (1999) Sensory responses and movement-related activities in extrinsic neurons of the cockroach mushroom bodies. *J Comp Physiol A* 185: 115–129
- Park J-M, Kunieda T, Takeuchi H, Kubo T (2002) DNA-binding properties of Mblk-1, a putative transcription factor from the honeybee. *Biochem Biophys Res Commun* 291: 23–28
- Park J-M, Kunieda T, Kubo T (2003) The activity of Mblk-1, a mushroom body-selective transcription factor from the honeybee, is modulated by the ras/MAPK pathway. *J Biol Chem* 278: 18689–18694
- Pianka ER (1970) On r and K selection. *Am Nat* 104: 592–597
- Ritzenthaler S, Suzuki E, Chiba A (2000) Myopodia: Postsynaptic filopodia that interact with innervating motoneuron axons. *Nature Neurosci* 3: 1012–1017
- Romer AS, Persons TS (1977) The vertebrate body. W.B. Saunders, Philadelphia
- Sachse S, Galizia CG (2003) The coding of odour-intensity in the honeybee antennal lobe: local computation optimizes odour representation. *Eur J Neurosci* 18: 2119–2132
- Sakura M, Mizunami M (2001) Olfactory learning and memory in the cockroach *Periplaneta americana*. *Zool Sci* 18: 21–28
- Sakura M, Okada R, Mizunami M (2002) Olfactory discrimination of structurally similar alcohols by cockroaches. *J Comp Physiol A* 188: 787–797
- Sone M, Suzuki E, Hoshino M, Hou D, Kuromi HH, Fukuda M, Kuroda S, Kaibuchi K, Nabeshima Y-I, Hama C (2000) Synaptic development is controlled in the periaxonal zones of *Drosophila* synapses. *Development* 127: 4157–4168
- Staudacher E, Schildberger K (1998) Gating of sensory responses of descending brain neurones during walking in crickets. *J Exp Biol* 201: 559–572
- Stopfer M, Bhagavan S, Smith BH, Laurent G. (1997) Impaired odour discrimination on desynchronization of odour-encoding neural assemblies. *Nature* 390: 70–74
- Stopfer M, Jayaraman V, Laurent G (2003) Intensity versus identity coding in an olfactory system. *Neuron* 39: 991–1004
- Stoykova A, Gruss P (1994) Roles of Pax-genes in developing and

- adult brain as suggested by expression patterns. *J Neurosci* 14: 1395–1412
- Strausfeld NJ, Hansen L, Li Y, Gomez RS, Ito K (1998) Evolution, discovery, and interpretation of arthropod mushroom bodies. *Learn Mem*. 5: 11–37
- Strausfeld NJ, Sinakevitch I, Vilinsky I (2003) The mushroom bodies of *Drosophila melanogaster*: an immunocytochemical and Golgi study of Kenyon cell organization in the calyces and lobes. *Microsc Res Tech* 62: 151–169
- Takeuchi H, Kage E, Sawata M, Kamikouchi A, Ohashi K, Ohara M, Fujiyuki T, Kunieda T, Sekimizu K, Natori S, Kubo T (2001) Identification of a novel gene, *Mblk-1*, that encodes a putative transcription factor expressed preferentially in the large-type Kenyon cells of the honeybee brain. *Insect Mol Biol* 10: 487–494
- Ueno K, Ohta M, Morita H, Mikuni Y, Nakajima S, Yamamoto K, Isono K (2001) Trehalose sensitivity in *Drosophila* correlates with mutations in and expression of the gustatory receptor gene *Gr5a*. *Curr Biol* 11: 1451–1455
- Vosshall LB, Wong AM, Axel R (2000) An olfactory sensory map in the fly brain. *Cell* 102: 147–159
- Wang JW, Wong AM, Flores J, Vosshall LB, Axel R (2003) Two-photon calcium imaging reveals an odor-evoked map of activity in the fly brain. *Cell* 112: 271–282
- Watanabe H, Kobayashi Y, Sakura M, Matsumoto Y, Mizunami M (2003) Classical olfactory conditioning in the cockroach *Periplaneta americana*. *Zool Sci* 20: 1447–1454
- Wehner R (1987) 'Matched filters' - Neural models of the external world. *J Comp Physiol* 161: 511–531
- Yasuyama K, Meinertzhagen IA, Schürmann F-W (2002) Synaptic organization of the mushroom body calyx in *Drosophila melanogaster*. *J Comp Neurol* 445: 211–226

(Received August 9, 2004 / Invited Review)