



Title	STUDIES ON FISHING GROUND, FISHING GEARS AND FISHING TECHNIQUE IN ONE-BOAT MEDIUM TRAWL FISHERY
Author(s)	SAITO, ICHIRO
Citation	MEMOIRS OF THE FACULTY OF FISHERIES HOKKAIDO UNIVERSITY, 5(1), 1-90
Issue Date	1957-12
Doc URL	<a href="http://hdl.handle.net/2115/21823">http://hdl.handle.net/2115/21823</a>
Type	bulletin (article)
File Information	5(1)_P1-90.pdf



[Instructions for use](#)

# STUDIES ON FISHING GROUND, FISHING GEARS AND FISHING TECHNIQUE IN ONE-BOAT MEDIUM TRAWL FISHERY

ICHIRO SAITO

*Faculty of Fisheries, Hokkaido University*

## CONTENTS

I. Introduction .....	2
II. Investigation of fishing grounds for one-boat medium trawl fishery .....	4
1. Application of the echo-sounder in trawl fishery .....	4
(1) Echo-sounder .....	4
(2) The application of the echo-sounder for fishing .....	5
(3) Application of echo-sounder especially to the one-boat medium trawl fishery ..	11
2. Vertical distribution and density of the population of demersal or bottom living fish in the sea northwest of Hokkaido .....	14
3. On the value of fishing grounds for trawl fishery in Musashi Bank and its surro- unding waters .....	24
(1) Introductory remarks .....	24
(2) Research boat, fishing gears and instruments .....	26
(3) Research method .....	26
(4) Shape and materials of the bottom .....	27
(5) The position, shape and bottom material of the shallowest part .....	29
(6) The range of waters which can be exploited as a trawl fishery ground .....	31
(7) The distribution and the amount of catch of the marketable kinds of bottom fish .....	32
(8) Musashi Bank as a trawl fishing ground .....	45
III. Studies on the fishing gears of the trawl fishing .....	46
1. Improvement of the net .....	46
(1) Introductory remarks .....	46
(2) Manila twine net of a new style .....	47
(3) Discussion .....	53
2. The strength of glass ball floats used in deep-sea fishing .....	54
IV. Studies on the methods of the trawl fishery .....	55
1. Relation between the amount of catch and the different ways of casting net .....	55
2. Ideal length of towing warp in relation to the depth of the sea-bottom .....	60
3. On the sinking velocity of the towing warp and net .....	62
4. On the state of a fishing gear under operation as observed by means of the submarine observation chamber "Kuroshio" .....	66
5. On relative superiority of the port and starboard side of the fishing boat in relation to the operation of the trawl net .....	69
6. Ecological studies on the fish shoal by an echo-sounder and its applications to fishing (on the Alaska pollack shoal) .....	73
V. General conclusion .....	77
Literature Cited .....	88

## I. INTRODUCTION

There are three kinds of offshore trawl fishery in Japan, (1) otter trawl fishery, (2) two-boats large trawl fishery and (3) one-boat medium trawl fishery.

The otter trawl fishery technique was imported from England. This fishery is carried on by one steel vessel above 200 gross tons having trawl net with otter boards.

The two-boats large trawl fishery was originated in Japan. Two boats of this class range in size from 50 to 130 gross tons. Two boats in pairs of the same type and same size draw each end of the towing warps in order to open and to spread the mouth of the net in place of using otter boards.

The one-boat medium trawl fishery was also devised in Japan. One boat of 15~75 gross tons draws the trawl net. In the waters surrounding Japan fishing boats of this kind are the most numerous. This method of fishing is to make a catch by scooping up the bottom fish by enveloping a sea-bottom area with long towing warp (manila rope) and fishing net without employing any otter board attached to the fishing net. One end of the towing warp is tied to a buoy, and the fishing boat sails her course casting the warp 3200~6400 meters in total length and the attached net.

After the boat has returned to the buoy and the towing warp and net have reached to the bottom, the boat begins hauling the two ends of the warp, keeping the wind and sea current astern. The warp and the net sunken in the water to the bottom take a rhombus or isosceles triangle shape and scoop the sea-bottom. Thus the bottom fish are caught.

The trawl fishery mentioned in this paper means the one-boat medium trawl fishing. The fishing technique and gears have remained almost unchanged in Japan for many years in spite of the enlargement of vessels and the development of marine engines, the fishing having been conducted on the basis of fishermen's functional experiences. They can use the nets only in coastal areas within sight of mountains or capes in spite of the excellent capacities of their fishing boats which are able to navigate pelagic fishing grounds. The fishing net is made only of thin cotton twine as in days of old, and furthermore its form has remained unchanged in the irrational shape of old time which can be called the period of the typical old-style Japanese ship. The length of the towing warp made of manila rope has not been rationally determined. Fishermen simply consider that the longer the rope the better the operation. They are accustomed to reckon the time needed for a thrown rope to reach the sea-bottom only by experience. They operate the net always at the port of the fishing boat only clinging to an old custom of the days of oars without considering the action of propeller of the vessel. The best manner of casting net having not been rationally determined, fishermen cast the net in various ways. After selecting a fishing ground, they operate the net by sense and experience without determining the shape of the sea-bottom or the presence of fish shoals. Therefore, they sometimes

lose many items of fishing gear in an unfamiliar fishing ground.

In 1948, the author first used a recording echo-sounder in the investigation of the fishing ground on the sea-bottom off Aomori Prefecture to clarify the nature of bottom materials and the shape of the sea-bottom. He discussed the character of a suitable trawl fishing ground.

During the period from 1949 to 1954, as a member of a committee on the investigation of the northern Japan Sea at Otaru, Hokkaido, the author engaged in the study of the nature of the fishing ground on the Musashi Bank or Musashi-tai by using the echo-sounder. He also studied the vertical distribution and density of various kinds of fish in the sea northwestward from Hokkaido.

The results of his scientific observations on the operation of fishing gear and fishing technique thus obtained, were published in the report on the investigation of fishery resources in Aomori Prefecture (No. 1 and No. 3) and in the report on the investigation of deep fishing ground of the northern Japan Sea (No. 1~No. 4).

In the present paper are summarized general conclusions derived from those investigational results, which are believed to offer the first scientific data concerning the fishing ground, fishing gear and fishing technique of the one-boat medium trawl fishing in Japan. The exploitation of the fishing ground around Musashi Bank has been carried on by the Bureau of Exploitation of Hokkaido and by the Hokkaido Fisheries Experimental Station. As to the trawl fishing ground around the bank, the author's data are believed to be the most scientific among those reported since 1925 when the Musashi Bank was discovered by a warship, the "Musashi". Such data will be significant for establishing a policy to improve the decayed fishery in fishing villages of Hokkaido, and also for exploiting a new fishing ground.

These studies have been carried on under the programs of the investigation of the deep seafishing ground in the northern Japan Sea and the investigation of aquatic resources in Aomori Prefecture, as well as during the fishing experiments conducted by the training ship "Hokusei-maru" of the Faculty of Fisheries, Hokkaido University, from 1948 to 1954.

The author wishes to take this opportunity to acknowledge his great indebtedness to several persons for their support in pursuing his investigation and in publishing the results.

Gratitude is first offered to Dr. Tetsuo Inukai, Professor of Hokkaido University, for his kind suggestions and criticisms in regard to this project. Thanks are offered to the members of the Association of Otaru One-boat Medium Trawl Fishery ("Otaru Kisen-sokobiki-ami Gyogyō Kyodō Kumiai") and of the Fisheries Division of Aomori Prefecture for their help.

To Dr. Risuke Yakuwa ex-Prof. of Hokkaido University, grateful acknowledgement is due for his kindness in reading and correcting the manuscript.

Thanks are also due to Prof. Jun Tokida and Prof. Eiichi Tanikawa for their helpful suggestions given in the course of preparation of the manuscript, and to Assistant Professors Takeji Fujii and Seikichi Mishima, Captain of the training ship "Oshoro-maru" and "Hokusei-maru" respectively, and to staff members of the Pelagic Fisheries Laboratory, Motokazu Ueno and Tatsuaki Maeda, who cooperated in this investigation.

Finally the author wishes also to express his gratitude to Miss Kano Noguchi and Messrs. Einosuke Tanaka and Terushige Motohiro for their aid in preparing the manuscript for publication.

## II. INVESTIGATION OF FISHING GROUNDS FOR ONE-BOAT MEDIUM TRAWL FISHERY

### I. Application of the echo-sounder in trawl fishery

#### (1) Echo-sounder

For the navigation of ships, sounding is as important as a cane is for a blind man. It helps a ship to steer clear of dangers when she approaches the land in a dense fog, mist, falling snow, or heavy rain-storms. Continuous soundings can determine the position of the ship by checking the chart. Sounding is customarily carried out by sinking a lead fastened to a wire cable to the sea-bottom by hand or by winch. However, sounding by wire cable is neither an easy task nor an accurate and convenient measure since it requires much time and labour on a running ship, especially when the water is greater than 100 meters in depth. The old type echo-sounder was an instrument from which strong sound waves were emitted toward the sea-bottom and the return echo was received. The difference of the time of sending and receiving the sound was converted into the depth. In recent years an elaborate recording super-sonic wave sounder has become popular. By using this instrument one can get accurate records of the depth, bottom materials and the shape of the bottom in a short time. The sounding machine which applies the super-sonic technique by using high voltage system was invented by Prof. P. Langevin of France. In place of a high voltage system super-sonic echo-sounder, the British Admiralty magneto-striction system recording echo-sounder was invented by the Admiralty Research Department of England by using nickel. This instrument makes use of a sonic wave of the order of 16000 cycles per sec.

In 1931, merchant ships in England were first equipped with this magneto-striction system recording echo-sounder the "Marconi Echometer". Since then, such instruments have been installed one after another on all English merchant ships. In Japan, the just mentioned echo-sounder was first installed on some ships of the old Japanese Navy and on some merchant ships in 1936, for making the safety of navigation, for facilitating a hydrographical survey, and for making a finding sunken ships.

## (2) The application of the echo-sounder for fishing

1) The training ship of Hokkaido University, the "Oshoro-maru", was equipped with a recording super-sonic echo-sounder (14.5 KC) "Type-3" of the Hydrographic Division of the former Japanese Navy. The author first used this instrument for an exploration of deep fishing grounds in the investigation of marine resources of Aomori Prefecture in 1948. In Japan, the echo-sounder has been applied for fishing after World War II and it has perhaps begun to be used in earnest since 1949. Since then, the echo-sounders of sonic waves, 14.5 KC, 20 KC, 35 KC, and 50 KC, were studied for use as surveyors of fish shoal, and they have become familiar to the fishery industry.

2) The author used at first "Type-3" of echo-sounder of the former Japanese Navy in 1948. Since 1949, he has employed "Type-100" echo-sounder (14.2 KC) made by Nippon Denki Co. for the investigation of trawl fishing grounds and for the survey of fish shoals. In the latter type, the transmitting system of applying the effect of magneto-friction was employed. The principle is that if the propagating velocity of sound-waves in water is known, and if the time which the sound-waves require to travel between the surface of the sea and sea-bottom is estimated, the time can be converted to the depth of the sea. The capacity of "Type-100" of echo-sounder made by Nippon Denki Co. is summarized as follows (Fig.1, a~e).

This echo-sounder consists of oscillator, indicator M G, amplifier, vibrator, resistor and charger. The range of sounding: 0~1800 meters; frequency: 14.2 KC; system of transformer; capacitor discharge; oscillator repetition rate: 100/min; recording system: linear moist recorder; vibrator: magneto-striction (96×150×132 mm); supply voltage DC. 24

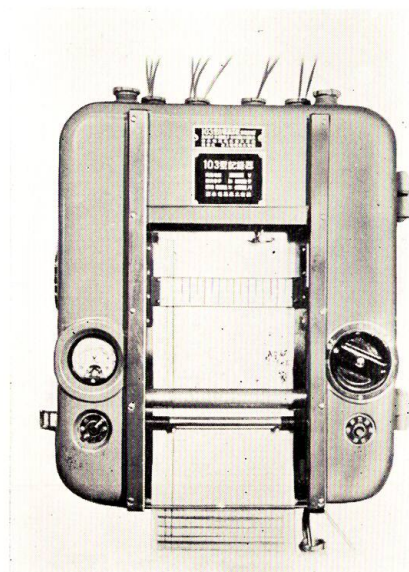

Fig. 1, a "Type-103" echo-sounder;  
indicator

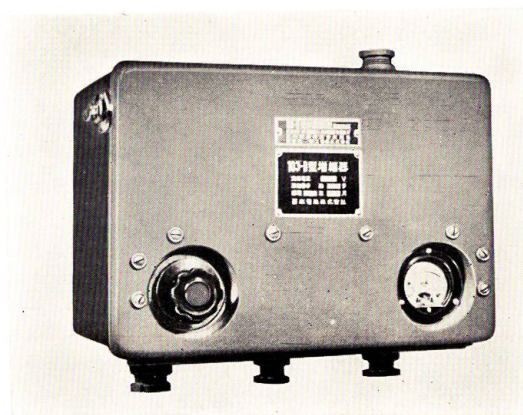

Fig. 1, b "Type-103" echo-sounder; amplifier

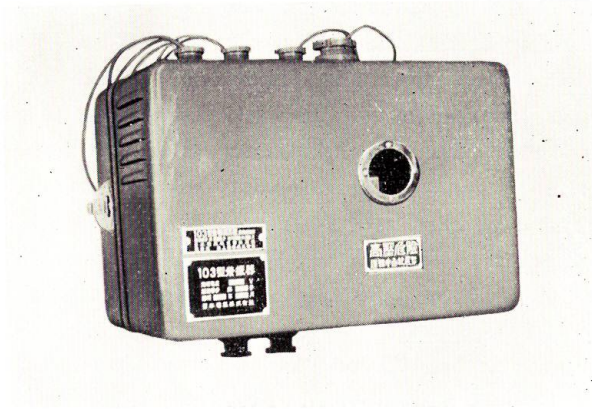

Fig. 1, c "Type-103 echo-sounder; oscillator

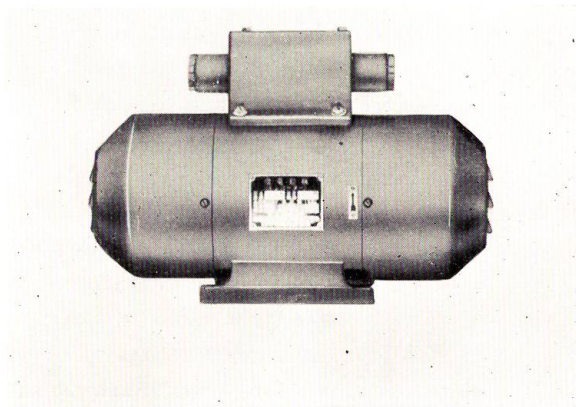

Fig. 1, d "Type-103 echo-sounder; inverter

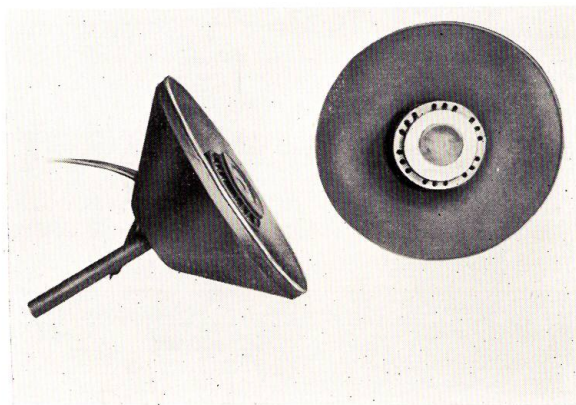

Fig. 1, e "Type-103" echo-sounder; vibrator

volt.

The echo-sounder is primarily a sounding instrument, so its sound-wave sender is not sharp in the direction at which the emitted sound-waves are pointed. It is desirable that the frequency of the sender would be small producing a small undiminishable wave and that the arrival distance of the wave would be large. If the frequency is larger, the pointing direction of sound-waves from a sender becomes sharp, but the arrival distance becomes short. Unlike the sea-bottom, a fish shoal is only slightly different in specific gravity from the sea water, so the effective reflection of sound is weak. Therefore, for the purpose of detecting a fish shoal, the weak echo must be amplified. An instrument has been devised which can record even a weak echo from fish shoal or plankton in the middle deep layer of the sea. Every effort has been made to realize a survey of fish shoal.

3) Fishing boats also apply the echo-sounder directly or indirectly to navigation and fishing. With regard to navigation, fishing boats, as well as merchant ships, can avoid the danger of stranding by continuously echo sounding the depth of the sea and the shape of the sea-bottom when the ship position is unknown or the visibility is poor. That is to say, the continuous records of sounding can yield important data for determining the position of the ship.

For instance, the author had an experience in 1951 in navigating a fishing boat in safety thanks to the echo-sounder which could check the irregular shape of the sea-bottom. In May and June, the fog is usually dense in the salmon fishing grounds off the eastern coast of Hokkaido, and fishing boats often find it difficult to enter Kushiro

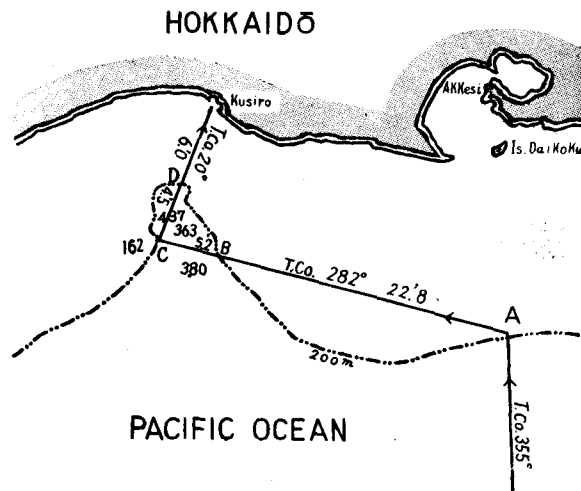

Fig. 2, An example of navigation when an echo-image of special sea-bottom was caught by the use of an echo-sounder



Harbor, the largest fishing and trading port on that coast. To the south of Kushiro, however, the continental shelf approaches the shore and has a narrow valley 380 meters deep. So a fishing boat from a southern fishing ground which seeks to enter Kushiro Harbor attempts first to discover the 200 meter line of the continental shelf by echo sounding and then sails to the west toward the valley keeping the echo-sounder in operation. When she catches a recorded image showing her arrival at the valley, she crosses the valley directly and takes a course to the north. If such a course is taken, the boat can come into Kushiro Harbor with safety even in a dense fog (Fig. 2).

4) Bonito is in the habit of gathering about a submerged huge rock. They gather mostly in the depth of 150 meters from the sea surface. Fishing boats can approach such a rock in ocean by celo-navigation and easily gain a good catch right above the rock located by the echo-sounder. Besides bonito, many other fishes are also found to live near the rock.

The reason why the fishes gather there can be explained by the accumulation of fish baits brought by the vertical disturbance of water owing to the upwelling of water which occurs near such a rock standing in the course of an under current.

The author once detected a crest of a submerged island at the depth of 207 meters, in the sea 800~2400 meters deep between two islets, Ōshima and Kojima by name, off the southwestern coast of Hokkaido, by means of an echo-sounder during the course of the investigation of sea-bottom of Aomori Prefecture. The outline of the shape and the size of the crest were learned by sounding as shown in Fig. 3, *a~b*. After the sounding was finished, a test fishing was done by angling the catch of Alaska pollack or "Suketodara" (*Theragra chalcogramma*). The catch proved larger at the crest than in the surrounding water.

For determining which is the best operating position in a fishing ground, the most important factor besides the water temperature is the quantity of natural food of fish especially when migratory fishes are concerned. Fish food in the form of young fish or plankton is easily gathered at a current-rip or "Shiome" under the influence of a water mass or sea current. Fish themselves are also gathered abundantly near the current-rip being driven by the ocean current and attracted by the specific water temperature.

These facts were already observed by Dr. Uda and Dr. Kimura and also by the present author (1953) occasionally during investigation of salmon and saury fishing grounds or of the squid angling fishing.

Further, it is advantageous for a good fishing to examine the nature of plankton organisms and seek after a current-rip at a fishing ground. The plankton can be taken by a plankton-net, and current-rip can easily be located by visual observation. However, it has become possible to detect a plankton accumulation in the sea by an echo-sounder or fish-finder, and to know the approach of a drifting boat to a current-rip by the echo-sounder even at night when the visibility is poor.

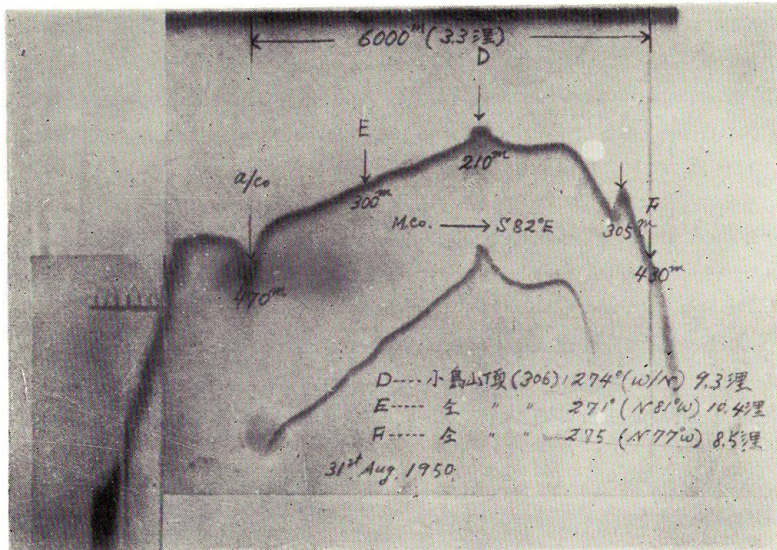

Fig. 3, a Echo-image of a ridge which was found by using "Type 3" echo-sounder off Kojima Is. in the sea southwestward from Hokkaido, in April 1948

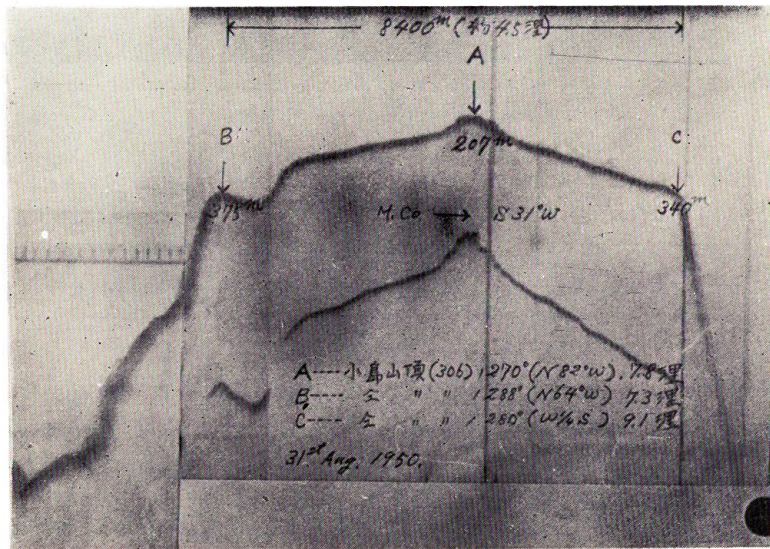

Fig. 3, b Echo-image of a ridge which was found by using "Type-3" echo-sounder off Kojima Is. in the sea southwestward from Hokkaido, in April 1948

Moore (1950) studied the relation between the movement of *Euphausiacea* and the deep scattering layer (D.S.L) which is impressed on the recording paper as an image by echo-sounder.

A number of studies concerning D.S.L. carried out in Europe and the U.S.A. are introduced to us by Uda (1952). The present author has obtained D.S.L.-like images off the eastern coast of Hokkaido by "Type-101" echo-sounder (14.2 KC. triple amplification system) made by Nippon Denki. Co. in the summers of 1950 and 1951. He also obtained by the echo-sounder an image of ascending *Euphausia pacifica* at sunset of a day in November 1952 off Esan Peninsula, Hokkaido. (cf. Bulletin of Hokkaido University Vol. 3, No. 4). In near future, in the fishery of salmon, saury and squid which are all migratory, the operating position at a fishing ground may be determined after learning the presence or absence of certain particular zoo-plankton species by an echo-sounder (Fig. 4).

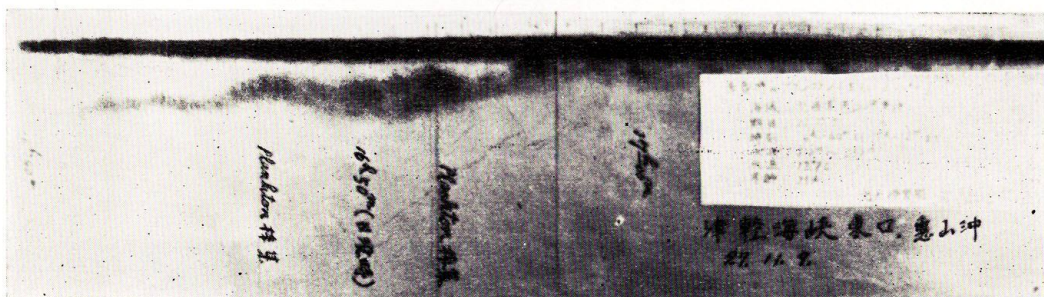

Fig. 4 Echo-image of *Euphausia pacifica* recorded by an echo-sounder, at sun set, off Cape Esan south coast of Hokkaido

5) It is important for fishing that it has become possible to locate a fishing ground by finding a crest of a submerged island or an accumulation of plankton; besides, the fishing may be done, of course, by watching directly the image of a fish shoal caught by an echo-sounder. Fishing can be said to have entered a new phase since the kinds of catchable fish and the presumptive amount of catch may be known in advance.

6) On the other hand, the echo-sounder has been applied to the ecological studies of fish shoals and to learning the habits of fish. Tester (1943~44) reports his observation on the vertical movement of a shoal of herring. In Japan, Kimura (1952) and others made a similar investigation on fish shoals of bonito, tuna, mackerel and sardine. The author (1952) observed the population of saury which gathered under a fish-alluring light in Tsugaru Strait. It was ascertained that a shoal of saury which gathered under the light formed, with the passing of the illuminating time, a deep layer around the light. From the recorded images of the echo-sounder, it was learned that the fish shoal which gathered at first to the light sank to a deeper level within

the attainable bounds of the light with the passing of time, and the fish shoal which gathered later swam near the surface of the sea (Fig. 5).

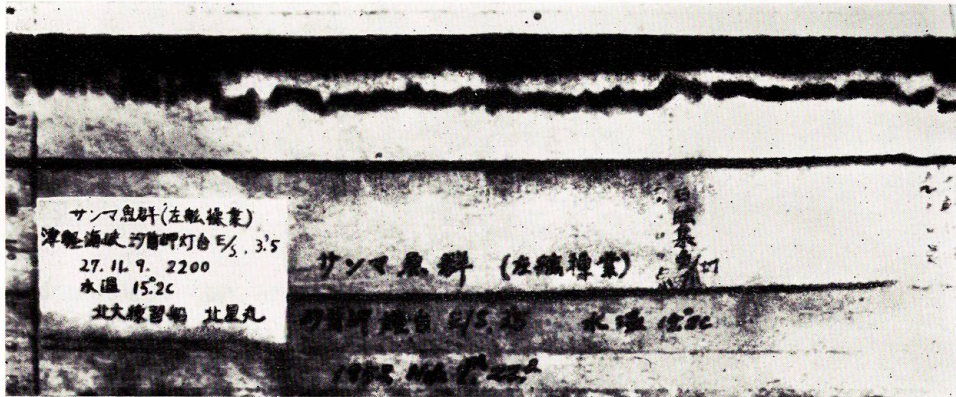

Fig. 5 Echo-image of the saury shoal gathering around a fish-alluring light in the Tsugaru Strait between Aomori Prefecture and Hokkaido.

### (3) Application of echo-sounder especially to the one-boat medium trawl fishery

1) The trawl fishing aims at the catch of fishes which live at or near the sea-bottom. So it is necessary to know the depth of the sea, the nature of bottom materials and the shape of the bottom for operating this fishery well. The depth of the sea is estimated, in conventional surveys, from a chart or by a hand sounding machine, and the bottom material is studied on the basis of samples gained by contact with the greased or soaped bottom of the lead connected to the sounding machine, or by bottom sampler. On the contrary, a survey by the echo-sounder enables the recording of the depth of the sea while sailing, from time to time, and the determination of the bottom material from the recorded image without using a bottom sampler. Hashimoto (1940, 1951) estimated the reflex index of ultrasonic sound waves and obtained 28% as the average value of the reflex of mud, 36% as that of sand, and 53% as that of rock. According to the strength of the reflected sound wave, the depth of the image on the recording paper shows variation. According to the change of the depth, the material of the sea-bottom can be assumed. For example, the index of reflection of rock is so strong that the corresponding image can be distinctly seen. The length of the image of echo is so characteristically short, that a second echo generates easily. The reflex of the echo of sand is weaker than that of rock, so that the second echo is not as distinct as that of rock. The image of the first echo returned by sand has a somewhat longer tail than that by rock, and the former is more distinct than the latter (Fig. 6).

The reflex index of mud is the least strong, so the echo becomes weak. The image

of the mud is characteristically light and has a long tail. For the sea-bottom in which the mud covers over the rock layer as in Aniwa Bay, Saghalien, the light image of the echo is recorded over the dense image (Fig. 7).

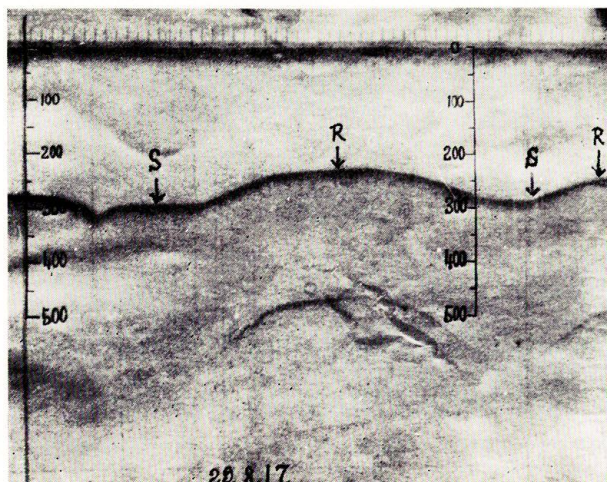

Fig. 6 Echo-image of rock and sand of sea-bottom  
R..... rock, S.....sand

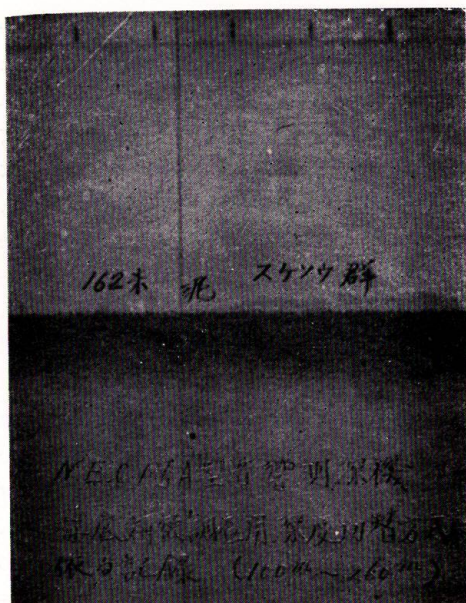

Fig. 7 Echo-image of the sandy mud bottom, depth 162 m, the trawl ground in waters to the south of Teuri Is.

To know the depth of the sea accurately is important not only to determine the length of the towing rope according to the depth of the sea, but also to keep the fishing efficiency during the operation. According to the results obtained by the author (1951) in the experiments carried out aboard the investigation boat "No. 5 Tenyū-maru", during the fishing of Atka mackerel (*Dleurogrammus azonus*) at night, a large amount of catch was made

at 93 meters depth. Similar amounts of catch could be continued by setting the net in position at the same depth over and over again. At that time many other fishing boats gathered in the same area, for fishing. However, no boat kept such a uniform catch as "No.5 Tenyū-maru" did. The amounts of catch of other boats were learned by wireless telephone. The cause of their failure in obtaining good catches was that they were unable to know not only their own position in the sea on account of the darkness of the night, but also they lacked any means to locate the sea area having a depth of 93 meters; they set their nets merely by guess-work.

2) In judging the shape of the sea-bottom, fishermen are used to determine the depth by chart or operating experiences. However, the condition of the sea-bottom

related to fishing cannot be known sufficiently from the depth described in the chart.

Even in trawl fishing grounds in the Eastern China Sea or Yellow Sea, which have wide areas of flat bottom, fish migrations take some fixed courses and fish are likely to gather to certain places. The fishing grounds for one-boat medium trawl fishing in the seas surrounding Honshu and Hokkaido are narrow and have many obstacles on the sea-bottom, and furthermore even the continental slope must be exploited ; there fish shoals are found to be present only at limited places and the loss of fishing gear due to obstacles on the sea-bottom is large. To surmount these difficulties some measures must be taken. As stated above, the author (1948) studied closely the undulating conditions of the sea-bottom and the nature of the bottom material by means of a recording system echo-sounder during the investigation of the trawl fishing ground of Aomori Prefecture. The attempted to judge the fitness of a bottom as a one-boat medium trawl fishing ground. These investigations using an echo-sounder were the first for one-boat medium trawl fishing. Since then the author has employed the echo-sounder in the investigation of sea-bottom fishing grounds in northern Japan Sea, in judging accurately and quickly the shape of the sea-bottom, depth of the sea and the nature of bottom material at unknown fishing grounds, and has succeeded in promoting effective fishing.

The extent of a prospective fishing ground is first determined by the size of area to be surrounded by the towing warp and net, and by the movable distance of the fishing gear on the very bottom of the sea, then a precise survey of the ground is done by echo-sounding prior to the cast of net in order to clarify the nature of the bottom material, the angle of the bottom slope, and the presence or absence of obstacles such as sharp angled rocks and under water reefs. To cast a net after finishing such a survey diminishes the loss of the gear due to the catch by a rock and prevents the damage of nets and towing ropes. Furthermore, even in a case where an echo-sounder of somewhat lower efficiency is used to detect obstacles on sea-bottom, it is seldom that the gears are caught by a rock which escaped detection, and thus there has been no incident of losing so large a part of the gears as sometimes happened to other fishing boats having no echo-sounder.

Considering the relation between the angle of the declination of the sea-bottom and towing warp, fishing on a flat sea-bottom must be easily performed. But sometimes it becomes necessary to operate fishing gears on a sloping ground according to the movement of a fish shoal. The angle of the slope can be determined from the sailing distance between two stations and the difference of their depths. The author (1950) once could tow the net over a slope  $12^{\circ}32'.7$  in angle without any difficulty. However, in such a place, the fishing efficiency is not high unless the fish shoal is large, owing to the slow movement of the gears and to the short time during which the net touches the sea-bottom before it rises from the bottom (Fig. 8).

If an echo-sounder is operated in the same sea area repeatedly during fishing or sailing, the characters and the shape of the sea-bottom will be well known by the

image impressed on the recording paper. Therefore, even when a ship's position cannot be determined by celo-navigation or by the azimuth of a cape, it may be determined by the image of the echo-sounder. Furthermore, it will become easy by the aid of the image to detect a fishing ground which is specially rich in fish shoals.

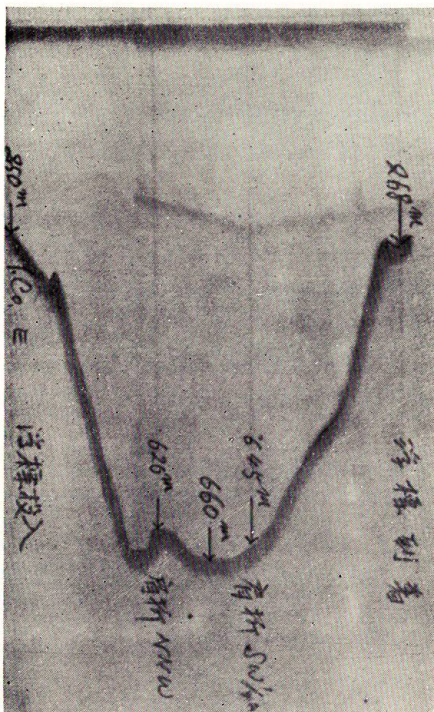

Fig. 8 Echo-image of the fishing operation on a bottom slope of  $12^{\circ}32.7'$  off Shakotan Peninsula

3) As mentioned above, the echo-sounder can be employed as a fish-finder. When the water is shallow, the images of a fish shoal and the sea-bottom are recorded together. The fish shoal may be found at the sea-bottom or near the upper margin of the trawl net; in the former case the image of fish cannot be distinguished from that of the sea-bottom. However, in the case of fish such as Alaska pollack, Atka mackerel and herring, which make a vertical movement from time to time, the fishing can be effectively operated, if their ecological characters are taken into consideration. The author once studied the action of Alaska pollack, especially its vertical movement at the spawning season, and could obtain good catches by adjusting the fishing method to accord with the results observed, as described in the latter part of this paper.

4) With the aid of an echo-sounder the sinking velocity of the fishing net was estimated by Hashimoto (1951) and that of

towing warp (manila rope) of the trawl net by the author (frequency 14.5 KC). (cf. IV-3)

The vertical width of the opened mouth of the trawl net towed by a fishing boat can be known from the echo-sounder images recorded by another ship that takes her position above the net mouth. Namely, the difference between the height of the sea-bottom's images and that of the net's images tells the vertical width of the net mouth. The net's images are due to the large reflex of the glass floats attached to the upper margin of the net mouth.

## 2. Vertical distribution and density of the population of demersal or bottom-living fish in the sea northwest of Hokkaido

(1) The continental shelf area of the sea has been considered a good fishing ground for surface migratory fish as well as for demersal ones.

Aikawa (1949) has divided the ocean from an ecological point of view into shallow area and medium depth bottom area with a boundary between the two at the mud line 200 meters deep. He has placed the lower limit of the medium depth area at about the line of 1000 meters deep. The water above the mud line at 200 meters depth is more or less remarkable in movement and is penetrated by sunlight which sustains the photosynthesis of marine plants.

On the contrary, in the water below this line as far down as the medium depth bottom area including the continental shelf slope, the sunlight hardly penetrates and movement of water mass, if it occurs, is very slight. Aikawa says further that the area below the depth of 800~1100 meters, or deep sea area, is dominated by darkness and stillness, and with the approach to that area the examples of the animal kingdom decrease. Each bottom area is inhabited by its characteristic fauna.

In the North Sea, it is said that the fishing of hake is occasionally operated at the sea bottom as deep as 300~630 meters. However, in Japan the otter trawl fishery as well as the large trawl fishery by two boats has developed as operations on the continental shelf at depths less than 200 meters; it was the same with the one-boat medium trawl fishery.

As stated by Aikawa (1949), the area of the sea bottom at less than 200 meters depth occupies only 17% of the whole ocean area on the globe, but this area is inhabited by a majority of the kinds and quantities of fish and other creatures to be found in all the oceans. However, even this continental shelf fishing ground is, in fact, approaching to devastation from the view point of trawl fishery.

The cause of that ruin may be considered attributable to over-fishing, or to changes in oceanographical factors, in shape of sea-bottom, or in bottom material. Such being the case, a new field of trawl fishery conceivably able to be developed is the continental shelf slope. The trawl net drawn by one-boat or by two-boats is considered to be suited for operating on the slope and especially the former is the most suitable as such operation has been learned by experience.

Investigations on fish and other creatures, experiments on fishing and research on fishery resources in the deep sea have been done by the Nagasaki Prefecture Fisheries Experimental Station and other fishery institutions.

Hazaki (1941) carried out fishing experiments by long line in the waters west of Koshiki Island of Kyūshū to depths of about 400 meters, and found that the bottom at 200 meters depth was most promising; Sakai and Uno (1943) used fixed long line and "Chikarazuna-type" bottom long line in the depths from 200 to 1000 meters in the area extending from the Kii Channel to the west of C. Shionomisaki. They reported that the fish that can be caught below 500 meter depths were deep sea shark (*Centrophorus acus*), "Birōdozame" (*Scymnodon squamulosus*), and "Sokodara" (*Coryphaenoides gramani*), and those caught above the 500 meter depths were red rock cod (*Sebastes matsubarae*), "Ara" (*Nippon spinosus*), dog fish (*Squalus suckleyi*) and rock fish (*Seba-*



*stiscus marmoratus*). Hanai (1943) caught cod (*Gadus macrocephalus*), Alaska pollack (*Theragra chalcogramma*) and arrow-toothed halibut (*Atheresthes evermanni*) at the depth of 200~300 meters, and arrow-toothed halibut, "Genge" (*Family Zoarcidae*) and whelk (*Babylonia japonica*) at the depths of 400~700 meters, by using a trawl net drawn by one-boat off Kitami, Hokkaido, as much as 260~520 kg per one fishing operation. The Faculty of Agriculture of Nagoya University and Aichi Prefecture Fisheries Experimental Station (1940~1953) made fishing experiments in the area from Cape Shionomisaki to Cape Muroto in the depths of 200~500 meters by using a trawl net; they caught "Nigisu" (*Argentina kagoshimae*), "Yumekasago" (*Helicolenus higendorfi*), "Sumikui" (*Synaagrops japonica*), "Ankō" (*Lophiomus setigerus*), "Same" (Shark sp.), "Ei" (*Family Rajidae*) and prawn in that area, which was reported to be promising as a fishing ground for deep sea trawl fishery. The Tōhoku Regional Fisheries Research Laboratory (1951) made fishing investigations in the depths of 500~1000 meters in northern waters along the Pacific coast of Aomori Prefecture from September to October by using trawl net drawn by two boats. According to the reports, a considerable amount of arrow-toothed halibut (*Atheresthes evermanni*), "Samegareii" (*Cliododerma asperrimum*) "Ōsaga" (*Sebastes iracundus*) and "Kichiji" (*Sebastolobus macrochir*) were caught in the depths up to 700 meters, but the catch became poor at 800~900 meters depth. Tabata (1953) of the Ishikawa Prefecture Fisheries Experimental Station did experimental fishing in the depths up to 500 meters off Noto Peninsula from September to January by using trawl net, and reported that the larvae of cod, "Hatsume" (*Sebastes owstoni*), and crab sp. could be caught at near the 200 meter line, sand fish (*Arctoscopus japonicus*), cod, and "Nametagareii" (*Microstomus kitaharae*) at 200~300 meters depth, and "Hatsume", cod, arrow-toothed halibut, prawn and crab sp. at 300~500 meters depth, and that the 250~370 meters depth was the most suitable fishing ground for trawl fishing in that sea area. The Wakkanai Branch of the Hokkaido Fisheries Experimental Station made fishing experiment using trawl net at 100~200 meters depth and at 300~600 meters depth in waters west of Rebun island. The catch of "Nametagareii", "Asabagareii" (*Lespidopsetta mochigarei*) at 100~200 meters depth was rather good, but the catch was very poor at 300 meters and deeper, where only a small amount of Alaska pollack, cod, "Urokomegareii" (*Acanthopsetta nadshnyi*), flat-head flounder (*Hippoglossoides dubius*), ray, "Genge" (*Family Zoarcidae*) and prawn was caught.

(2) The present writer did experimental fishing in the sea northwest of Hokkaido from 1949 to 1954, mainly in summer, by a trawl net drawn by one boat on the continental shelf which has been said most suitable as a fishing ground for trawl fishery and on the continental shelf slope which has been considered ranking next in the suitability to the former. He could learn in general the vertical distribution and population density of demersal fish. From this experiment, moreover, characteristics desirable in a trawl net fishing ground became known more accurately than ever.

So the writer proposes to report here the details of his research.

The boat employed for this research was a training ship of the Faculty of Fisheries, Hokkaido University, "Hokusei-maru" (104 Tons, 210 H.P.). The fishing gear employed was a trawl net without otter boards drawn by one boat. The towing rope or warp was 24 maru in Japanese units, or 4800 meters long, for depths less than 400 meters, and 32 maru, or 6400 meters long, for depths greater than 400 meters. The observational instruments were echo-sounder (Kaijo-Denki Co. Type "103"), electric sounding machine (Tsurumi Seiki Co., T. S. type "I", DC. 105 V, 2 H.P.), Kitahara's insulated water bottle, Nansen's reversing thermometer, Marukawa's bottom sampler and hand sounding machine, etc.

The investigated area covered the sea-bottom 300~850 meters in depth, in the sea northwest of Hokkaido, ranging from Cape Kamoi to Rishiri and Rebun islands through Ishikari Bay, Ofuyu Peninsula, off Rumoe and around Teuri Island (Fig. 9).

(3) The net towing for research was operated 181 times during the period from 1949 to 1954; the number of operations for each depth of water is shown in Table 1.

The catch of fish at each depth shown in Table 1 cannot be concluded, of course, to represent all the inhabitants at that depth.

That is to say, the quantity and quality of catch cannot be absolutely accurate because it varies according to the ratio of the length of towing rope to the depth of the fishing ground, the towing speed of the fishing boat, the annual change in the amount of the resources, the inaccuracy in determining the inhabiting depth of marine creatures owing to the separation of water depth with the differences ranging from 50 to 200 meters, diurnal change in vertical movement of fish and to mingling of upper layer

nektic fish in the catch during hauling of the net. However, a fishing experiment by trawl net can be expected to give more accurate data of fish distribution than that one done by means of angling which depends only upon the feeding habit of fish; the former is considered satisfactory as a means of surmising the general distribution of demersal fish and the profitable depths of water for fishing operations.

Fig. 10 shows the range of the depths at which various kinds of demersal fish were caught in this investigation and their density of population. Table 2 shows the unit amount of catch of the valuable demersal fish for each depth of the sea. The population of the demersal fish for each depth may be summarized as follows.

1) 30~50 meters deep bottom

This is most shallow depth studied in this investigation. The fish caught at this

Table 1. Number of experimental fishing operation for each depth of water in the research carried out during the period from 1949 to 1954

Depth (m)	No. of operations
30- 50	6
51-100	20
101-200	94
201-300	38
301-400	12
401-600	6
601-800	3
801-900	2
Total	181



The following is a list of fish which were caught during this investigation.

Japanese name (English name)	Scientific name
"Hirame" (Bastard halibut)	<i>Paralichthys olivaceus</i> (TEMMINCK et SCHLEGEL)
"Kurogashiragarei" (Flounder sp.)	<i>Limanda schrenki</i> (SCHMIDT)
"Sunagarei" (Flounder sp.)	<i>Limanda iridorum</i> (STEINDACHNER)
"Kanagashira" (Sea robin)	<i>Lepidotrigla microptera</i> GUNTHER
"Kitsunemebaru" (Rock cod sp.)	<i>Sebastichthys vulpes</i> (STEINDACHER et DÖDERLEIN)
"Asabagarei" (Flounder sp.)	<i>Lepidopsetta mochigarei</i> SNYDER
"Ohyō" (Halibut)	<i>Hippoglossus stenolepis</i> SCHMIDT
"Nishin" (Herring)	<i>Clupea pallasii</i> CUVIER et VALENCIENNES
"Tokubire"	<i>Podothecus sachi</i> (JORDAN et SNYDER)
"Aburazame" (Dog fish)	<i>Squalus suckeyi</i> (GIRARD)
"Yanaginomai" (Rock fish sp.)	<i>Sebastes steindachneri</i> (HILGENDORF)
"Hatsume" (Rock fish sp.)	<i>Sebastes owstoni</i> (JORDAN et THOMSON)
"Magarei" (Flat fish)	<i>Limanda angustirostris</i> KITAHARA
"Hokke" (Atka mackerel)	<i>Pleurogrammus azonus</i> JORDAN et MOTZ
"Suketōdara" (Alaska pollack)	<i>Theragra chalcogramma</i> (PALLAS)
"Nagazuka"	<i>Dinogunellus grigorjewi</i> (HERZENSTEIN)
"Nametagarei" (Flounder sp.)	<i>Microstomus kitaharae</i> JORDAN et STARKS
"Akagarei" (Flat-head flounder)	<i>Cynopsetta dabia</i> SCHMIDT
"Hatahata" (Sand fish)	<i>Arctoscopus japonicus</i> (STEMDACHNER)
"Sōhachigarei" (Flounder sp.)	<i>Protopsetta herzensteini</i> (SCHMIDT)
"Aburagarei" (Arrow-toothed halibut)	<i>Atheresthes evermanni</i> JORDAN et STAKS
"Madara" (Cod)	<i>Gadus macrocephalus</i> TILESIIUS
"Tsumagurokajika"	<i>Gymnocanthus herzensteini</i> JORDAN et STARKS
"Madako" (Octopus)	<i>Octopus vulgaris</i> (LAMARCK)
"Mizudako" (Octopus)	<i>Octopus dofleini</i> WULKER
"Urokomegarei" (Flounder sp.)	<i>Acanthopsetta nadeshnyi</i> (SCHMIDT)
"Ainukasube" (Ray sp.)	<i>Raja smirnovi</i> SOLDAROV et PAVLENKO

"Makasube"	<i>Raja purchra</i> LIU
"Surumeika" (Squid)	<i>Ommatostrephes sloani pacificus</i> STEENSTRUP
"Bōzuika" (Squid sp.)	<i>Rossia pacifica</i> BERRY
"Dosuika" (Squid sp.)	<i>Gonatus magister</i> BERRY
"Toyamaebi" (Prawn sp.)	<i>Pandalus hypsinotus</i> BRANDT
"Hokkokuakaebi" (Prawn sp.)	<i>Pandalus borealis</i> KROYER
"Genge"	<i>Petroschmidia toyamensis</i> KATAYAMA
"Ezomebaru" (Rock cod sp.)	<i>Sebastes tazancwskii</i> (STENDACHER)
"Abachan"	<i>Crystallias matsushimae</i> JORDAN et SNYDER

Table 2. Vertical distribution of bottom fish

Depth (m)	Kinds															
	Eastard halibut	"Kurogashiragarei"	"Sunagarei"	Sea robin	"Kitsunemembaru"	"Asabagarei"	Halibut	Herring	"Tokubire"	Dog fish	"Yanaginomai"	"Hatsume"	Flat fish	Atka mackerel	Alaska pollack	"Nagazuka"
30-50	2.7	2.2	19.1	23.0									3.7			
51-100				0.1	8.5	7.6			1.5				1.1	7.8		0.1
101-200						0.8		0.1	0.3		0.8	0.2	0.1	54.2	16.6	6.3
201-300						0.4	0.3			0.6	6.6	4.4		14.5	22.5	4.3
301-400												2.7			22.3	
401-600														0.1	5.8	0.1
601-800																
801-900																
Total																

average catch at each depth.

2) 51~100 meters deep bottom

At this depth, "Asabagarei", "Nametagarei", flat-head flounder, "Sōhachigarei" began to be caught. "Kitsunemembaru" was caught only at this depth. Some amount of Atka mackerel and cod began to appear in the catch too, but Alaska pollack did not yet. "Tsumagurokajika" was largest in the amount of catch at this depth. In the summers when this investigation was carried out, fish found at this depth were generally young.

3) 101~200 meters deep bottom

At this depth, the number of kinds of fish and the amount of catch per unit operation were largest of all, the amount corresponding to 35% of the total catch from all the depths investigated.

Atka mackerel, "Tsumagurokajika", "Urokomegarei", octopus, flat-head flounder,

"Nametagarei", "Nagazuka" were especially large in their density of population. "Hatsume", "Yanaginomai", etc., were caught at this depth but not from shallower waters. The non-migratory herring was caught only at this depth near the sea-bottom but not at any other depth.

4) 201~300 meters deep bottom

This is situated near the boundary between the medium depth bottom area and that shallow bottom area. The amount of catch from this depth was next to that from the bottom of 101~200 meters deep. This is the optimum depth for Alaska pollack, flat-head flounder, "Urokomegarei", Atka mackerel, cod, "Yanaginomai", "Hatsume", and prawn; halibut and dog fish were caught only at this depth. The amount of catch per unit haul was next to that from the 101~200 meters deep bottom and corresponded to 24.5% of the total amount of catch.

by depth in the sea northwest of Hokkaido

"Nametagarei"	Flat-head flounder	Sand fish	"Sohachigarei"	Arrow-toothed halibut	Cod	"Tsumagurokajika"	Octopus sp.	"Urokomegarei"	Skates & rays	Squid sp.	Shrimp & prawn	"Genge"	"Abachan"	Total	%
							0.3		0.6					51.6	10.4
4.4	2.2		4.8		0.4	22.6	1.1		4.7	0.1				66.4	13.3
8.1	12.4		1.4	0.1	4.4	35.6	13.2	19.7	0.1					174.3	35.0
2.4	23.3		0.5	0.2	7.9	8.5	2.1	20.6		0.1	2.7			121.9	24.5
	2.8	0.5		0.3	9.3			8.3	0.1		0.5	0.1		46.6	9.4
	0.1				2.6		0.1	15.5	1.3	0.1	0.8	0.1	0.2	26.8	5.4
				0.2				2.5	1.5	0.1		0.5	0.5	5.3	1.1
					0.3	0.2	1.0	0.1	2.5	0.2	0.1		0.1	4.5	0.9
														497.4	100.0

5) 301~400 meters deep bottom

At this depth the number of kinds of fish and their density of population remarkably decreased. However, Alaska pollack, cod, and "Urokomegarei" were comparatively abundant, and flat-head flounder, "Hatsume" and prawn were also worth fishing. On the contrary, Atka mackerel, "Nametagarei", and "Tsumagurokajika" disappeared. The amount of catch per unit haul corresponded only to 9.4% of the total.

6) 401~600 meters deep bottom

As valuable fish at this depth, Alaska pollack, cod and prawn only were worth mentioning. However, their amount of catch was very small. "Urokomegarei" was caught in a remarkable amount. "Dosuika", "Genge" and "Abachan" were found to be abundant at this depth.

7) 601~800 meters deep bottom

Most of the valuable fish were absent from this depth. "Urokomegarei", ray,

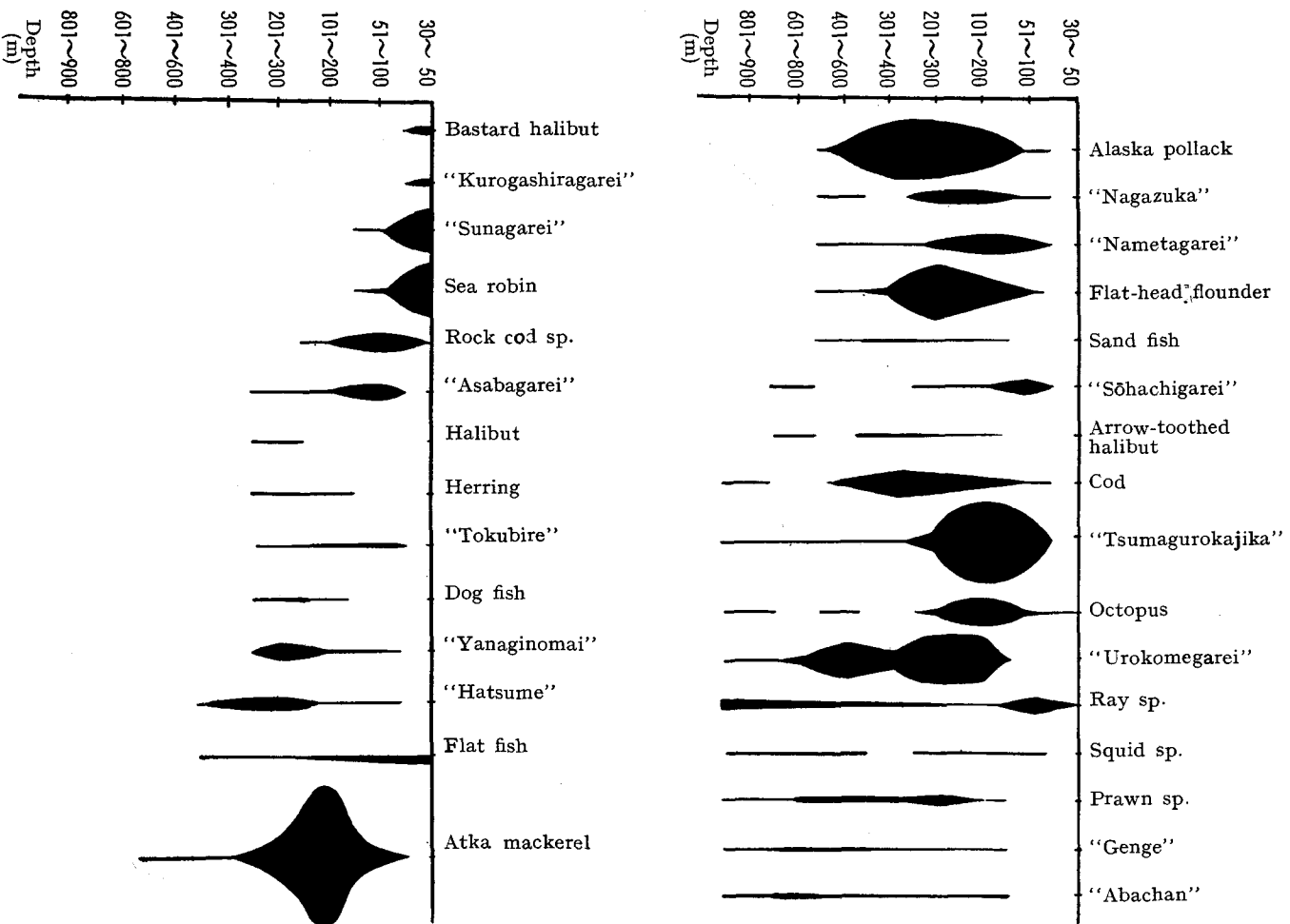

Fig. 10. Vertical distribution and density of bottom fish in the sea northwestward from Hokkaido

“Genge” and “Abachan” were the only exceptions. Red crab (*Chionecetes opilis*) and “Makigai” (*Chrysodomus liratus*) were caught together with others. However, the population density of those fish was very small, and the amount of catch per unit haul was 1.1% of the total.

8) 801~900 meters deep bottom

Conditions are similar to those of the preceding; ray, octopus of small size, “Urokomegarei”, “Abachan” and “Dosuika” were dominant among the catch. In table 2, cod and “Tsumagurokajika” are recorded to have been caught at this depth. They were perhaps caught by the net during its hauling while they must have been swimming according to their habit in the middle depth water layer.

The vertical distribution of fish and their density of population at each depth may be summarized as follows :

Halibuts and flounders are mostly living in shallow sea-bottom area, while flat-head flounder, arrow-toothed halibut, “Urokomegarei” are living in deeper waters and become abundant in the medium depth bottom area. Other fish such as sea robin, “Kitsunemebaru”, Atka mackerel and “Tsumagurokajika” are distributed mostly in shallow sea-bottom. Marketable fish living in waters 300 meters and more deep are Alaska pollack and cod together with a small amount of “Hatsume” and prawn. Generally speaking, the number of kinds of fish and their density of population are greatest in the depths between 100 meters and 300 meters. The area between 150 meters and 220 meters, keeping the center at 200 meters, is most densely populated by fish. Below 400 meters, Alaska pollack, cod and prawn (*Pandalus borealis*) are very sparsely distributed. Therefore, the value as a fishing ground utterly declines at depths below 400 meters where there are found besides the above mentioned fish some almost valueless ones such as “Urokomegarei” “Abachan”, “Genge” and Ray sp. (Fig. 10).

(4) To discuss the relation between the value of fishing ground for trawl net operations and the depth of the sea, on the basis of the vertical distribution of fish, the most valuable depth for fishing in the sea northwest of Hokkaido in summer is around 200 meters. At least about 60% of the amount of valuable fish are caught in the depth ranging between 100 meters and 300 meters.

The reason is, as Aikawa (1949) says, that the water above the 200 meter mud line is good for the living of fish because there is violent movement, and it is well penetrated by sunlight. Thus it becomes a place populated by phyto and zoo-planktons, and fish larvae fitted as feed of fish.

Especially on the continental shelf slope, upwelling currents and eddies may be generated, and circulation and mixing water, may become remarkably good, so that the multiplication of plankton may be accelerated and the growth of benthos may increase, and consequently the natural feed of fish may become abundant. In summer, near the 200 meter depth line, cold upwelling currents along the slope of the con-



tinental shelf may have marked influence on the sea-bottom temperature. As a matter of fact, the water temperature at the bottom 200 meters deep was often observed in summer to be 3~6°C while it was as high as 10°C at the bottom less than 100 meters deep. Therefore, Atka mackerel, flat-head flounder, Alaska pollack, "Kajika" (*Gymnocanthus herzensteini*), etc., which have a liking for comparatively lower temperature are considered to migrate seeking their optimum temperature and to come to that depth.

According to the results of the investigation by the Tōhoku Regional Fisheries Research Laboratory in the sea southeast of Hokkaido (off the northern coast of Aomori Prefecture), as well as to those of other deep sea investigations, there may be valuable water depths for fishery even below 500 meters. However, in the sea area northwest of Hokkaido, the limit depth for profitable fishery is at 400 meters. According to the results obtained by the experimental fishing operated for short periods in February,

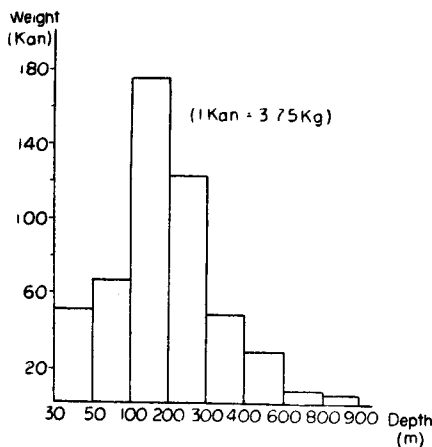

Fig. 11. Amount of average catch per one haul by depths

May and October, various kinds of demersal fish were found to decrease remarkably in waters below 400 meters deep. A cause of such a difference between the distribution of fish in the Pacific coast area as reported by the Tōhoku Regional Fisheries Research Laboratory and that in the Japan Sea coast area of Hokkaido as studied by the author may be attributable to the ecological relationships due to the difference of fish kinds. As for other causes of the difference, future studies are needed before comment can be made. Generally speaking, the fishing ground for trawl fishery by the "one-boat" type medium trawler in the sea area northwest of Hokkaido should be chosen at the continental shelf, especially near the 200 meter line, except when certain specific fish kinds of winter are aimed at. The next best fishing ground is at sea depths down to 400 meters on the continental shelf (cf. Fig. 11: The average catch at each depth per one haul).

### 3. On the value of fishing grounds for trawl fishery in Musashi Bank and its surrounding waters

#### (1) Introductory remarks

Musashi-tai or Musashi Bank is a shallow bank which was discovered by the surveying ship "Musashi" in 1925. Its position is 70~120 nautical miles to the north-

north-west from Otaru Port and 50~80 nautical miles off the coast of Teshio district in Hokkaido. The bank is 60 nautical miles long from north-north-west to south-south-east, and about 30 nautical miles wide. Musashi Bank and its surrounding waters have been noted as an angling ground for cod since its discovery. In 1925~26, Shirai and Imaizumi investigated it as an angling ground. After that, a few brief reports were published by Ando and others. However, its value as a fishing ground has remained unknown. It may be worth mentioning that no investigation of the bank as a fishing ground for trawl fishery has ever been carried out.

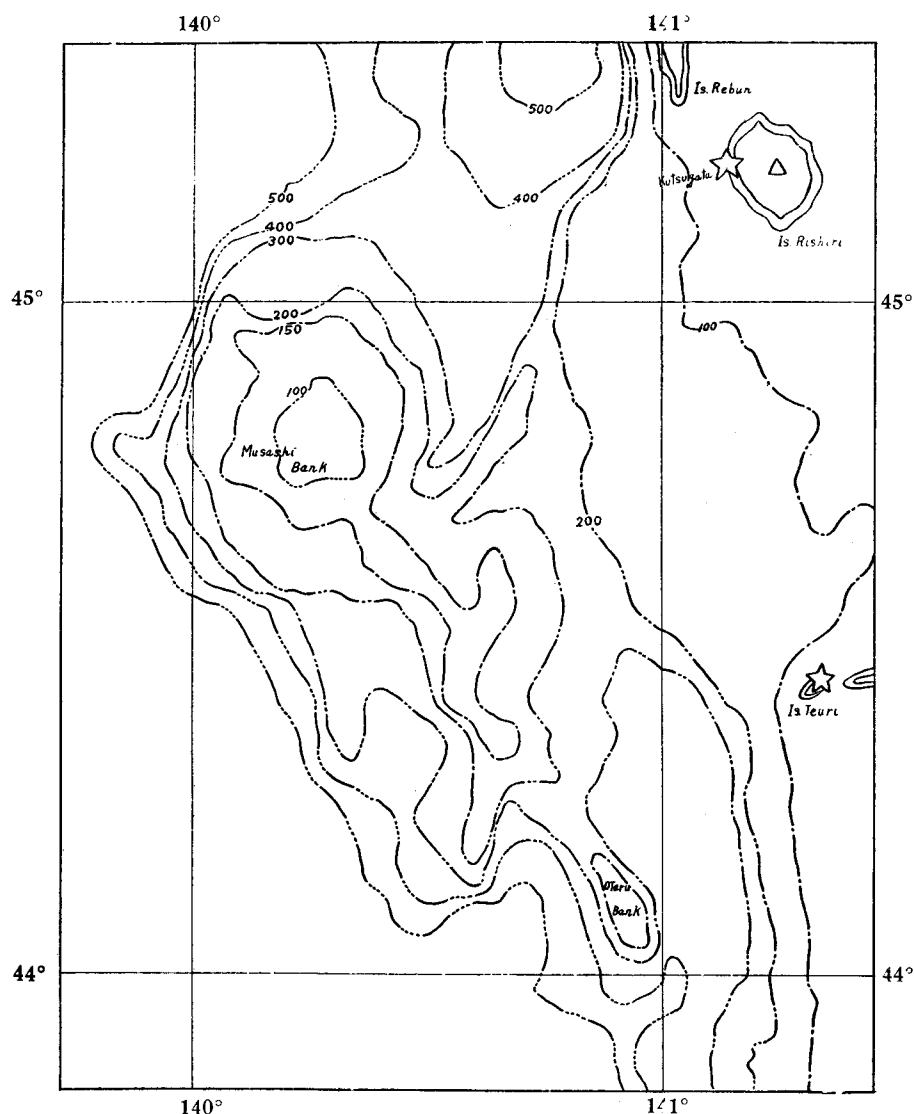

Fig. 12. Chart of trawl fishing ground near the Musashi Bank

In order to ascertain the value of the bank as a fishing ground for trawl fishery, the author studied the conditions of Musashi Bank from 1949 to 1954, mainly in summer, but also for short periods in the months of February, March, May, September and October, by using an echo-sounder, a deep sea diving-apparatus and other oceanographical instruments. The fishing experiments by trawl net without otter boards drawn by one boat was also practiced 46 times within those periods. As a result, the shape and the materials of the sea-bottom, the range of area suited for a fishing ground, the kind of important demersal fish, their distribution, and the amount of catch were learned (Fig. 12).

### (2) Research boat, fishing gears and instruments

The research boats used were a training ship of the Faculty of Fisheries, Hokkaido University, "Hokusei-maru" (104 Gross Tons, Diesel engine 210 H.P.), and a research boat of the Association of Medium Trawl Fishery at Otaru, "No. 5 Tenyu-maru" (64 Gross Tons, Diesel engine 210 H.P.). Fishing gear was a trawl net without otter boards drawn by one boat, made of cotton yarn and manila twine. Instruments and gear machines were a recording type echo-sounder (Nippon Denki Co. Type "103"), an electric sounding machine and a hand sounding machine (Tsurumi Seiki Co.), an electric depth-meter, a Nansen's reversing thermometer, a Kitahara's water sampler, a Marukawa's bottom sampler, and deep sea diving apparatus.

### (3) Research method

At first, Musashi Bank and its surrounding waters were thoroughly sounded by the echo-sounder and other instruments. The range of waters where experimental fishing should be carried out was especially surveyed in detail by the echo-sounder. Before setting the net, the shape of bottom, the sea depth, the presence or absence of obstacles were studied by sailing on the course which would be taken when the net was set.

In judging the bottom material, a sounding lead and a bottom sampler were employed in addition to the echo-sounder in order to gain certainty. The length of towing manila rope was determined in accordance with the depth of the sea. The number of revolutions of the main engine was regulated, taking into consideration the velocity of wind, wave and tidal current, to keep the towing speed of the net over the bottom at 1.5 nautical miles per hour. In determining the ship's position, the fix by cross bearing, fix by transit and by bearing etc., and celo-navigation accompanied with echo-sounding method, were employed. Experimental fishing was made mainly in the daytime from early dawn till dusk. Fishing at night was done only rarely. In investigating the shallowest part of Musashi Bank, the ship was anchored by dropping both stern and bow anchors, and the position of the part of the Bank under investigation was determined by celo-navigation; then the bottom material and demersal creatures were collected by a deep sea diver. The shape of the bottom was also observed at the same time.

## (4) Shape and materials of the bottom

From the data of a basic survey on the depth and the bottom material made by the training ship "Oshyoro-maru" (616 Gross tons, Diesel eng. 800 H.P.) of the Faculty of Fisheries, Hokkaido University, all over the sea areas northwest of Hokkaido in 1949, Kato (1949) has prepared a provisional chart of the deep sea fishing grounds in northern Japan Sea; Tomabeji (1949) investigated the shape of the bottom and the distribution of bottom materials; Kato and Okuda (1949) reported their research on the bottom materials as an environmental factor of a fishing ground; Fukutomi *et al.* (1949) reported on the result of their oceanographical investigation; Motoda (1949~1951) on the distribution of the plankton, and Hikita (1950~1952) on the kinds of fish and other creatures collected in this investigation.

According to the results obtained by the present author (1949~1954), (Fig. 12,13),

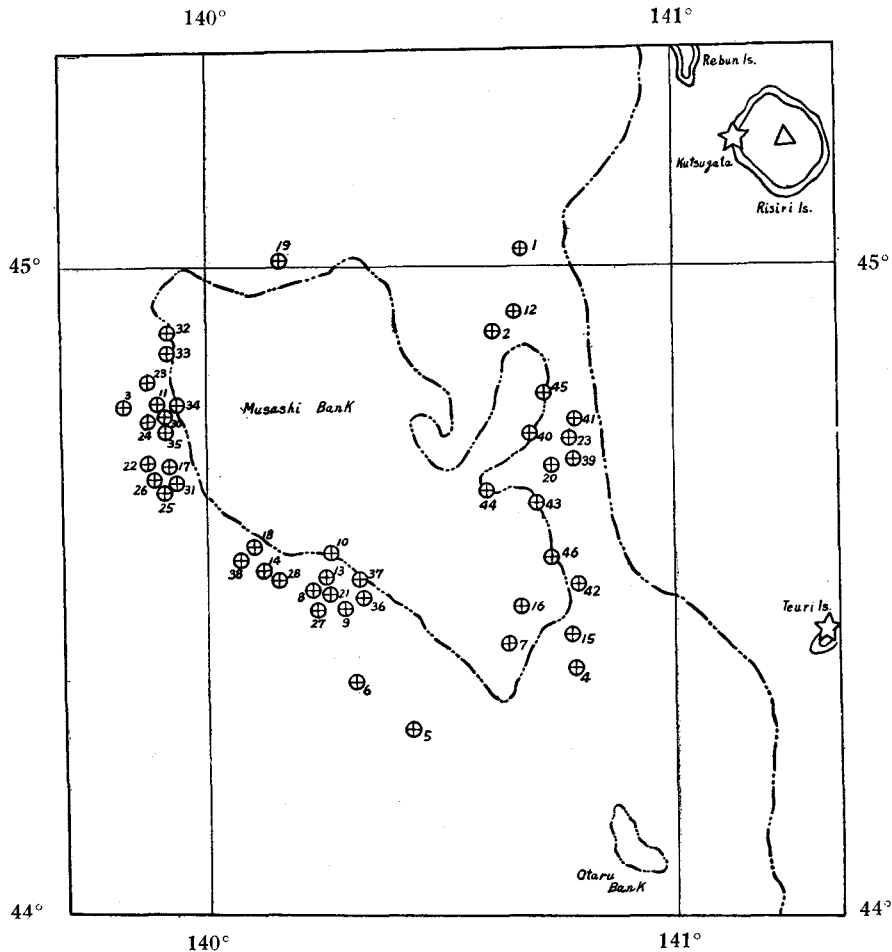

Fig. 13. Experimental stations of trawl fishing ground near the Musashi Bank

Musashi Bank, if the water range above 200 meters deep line is taken into consideration, is a long narrow shallow bank extending over about 57 nautical miles from north-north-west to south-south-east, with the summit 10 meters beneath the water surface at lat.  $44^{\circ}48'N$ , long.  $140^{\circ}18'E$ . From near the center of the bank, a shallow bank which is called "Tengu no hana" ("Nose of the long-nosed goblin") projects north-eastward. The water range above 100 meters deep line is nearly pentagon in shape, about 10 nautical miles from south to north and about 8 nautical miles from east to west, with the center at the summit of the bank. The water range above 300 meters deep line is wide from south to north and narrow at the western side. In other words, the bank has comparatively gentle slopes on the northern, eastern, and southern sides while it has a rather steep slope on the western side. The sea-bottom on the bank was observed to have no large undulation but small unevennesses in some places.

Fig. 14 shows the image of the sea-bottom on the bank as was obtained by an echo-sounder in August 1953 while sailing from the peak of the bank at the shallowest part (10 meters in depth) to east, west, south and to north. The ship was sailed first from the shallowest part of the bank to the north for 10 minutes at the rate of 7.06 nautical miles per hour, then to the south-west as far as a spot directly west of the shallowest part, next to the east at the rate of 6.94 nautical miles per hour, and after crossing over the shallowest part to the east for 10 minutes more. Then she was sailed to the south-west as far as a spot directly of the shallowest part, next to the north at the rate 6.82 nautical miles per hour, and at least she arrived back at the starting point above the shallowest part of the bank.

At that time, the author dropped anchor at the shallowest part of the bank (10 meters depth) and determined its position accurately by celo-navigation. The position of this shallowest part of the bank described on chart No. 41 published by the Hydrographical Department was ascertained to differ from the actual position determined by the author by 1.8 nautical miles to the south  $60^{\circ}$  east. The position of the shallowest part and its bottom materials will be described in the next section.

The bottom material in the water area less than 200 meters deep is mostly rock, excepting for some sandy parts in the eastern area and a few gravel parts in some others. The bottom surrounding the Musashi Bank is composed of sand or sandy mud. Kato (1949) reported, after summarizing the relation between the water depth and the size of the bottom material grains, that the bottom in the water shallower than 300 meters consisted frequently of sand, sandy mud or muddy sand while the bottom at depths below 300 meters consisted of muddy sand or mud. The results of the author's research are in agreement with Kato's report. According to the results of the experimental trawling, the bottom in the water shallower than 260 meters, even if it consists of sand or sandy mud, is covered with something like scattered bare rocks so small as to be undetectable by the echo-sounder (14.5 KC) and so the operation of a fishing gear sometimes happens to encounter trouble through its being frequently

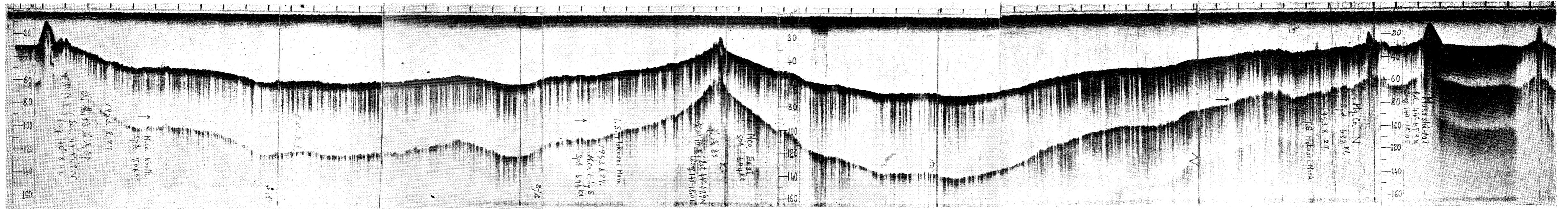

Fig. 14 Echo-images which were recorded by an echo-sounder as the ship sailed from the shallowest part of Musashi Bank to east, west, south and north direction

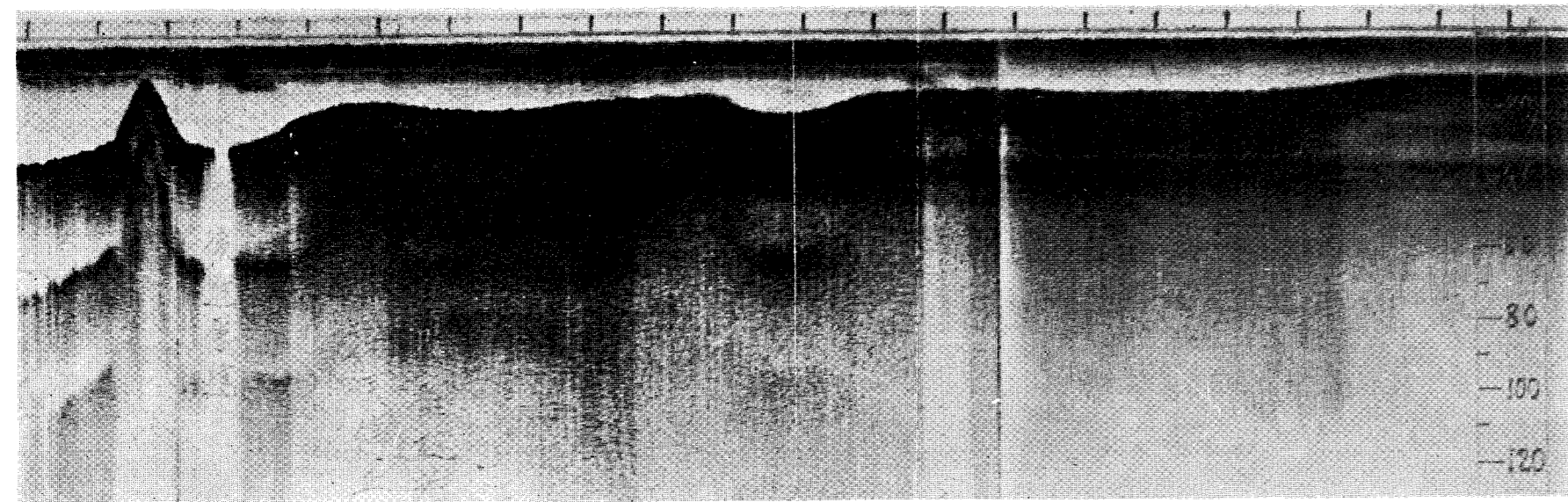

Fig. 15 Echo-image by which the shallowest part of Musashi Bank was ascertained

caught by those rocks or by having nets broken. However, in the eastern part, even at 180~200 meters depth, there are many suitable places for fishing operation.

Note : At the time when the surveying ship "Musashi" discovered the Musashi Bank, the shallowest part of the Bank was reported to be about 26 meters deep. According to Imaizumi's report (Hokkaido Fisheries Experimental Station) in 1926, Captain Otozō Natsumi of the "Seiho-maru", a fishing boat of Otaru, found a shallower part 7.5 meters deep; it was about 1500 meters in length, and about 20 meters in width. However, the position of that area has not been precisely known.

(5) The position, shape and bottom material of the shallowest part

1) Since the discovery of the Musashi Bank in 1925, it has been exploited as an angling ground. Fishing boats seem to have gone to the shallowest part of the bank for angling "Kitsunemebaru" (*Sebastichtys vulpes*) and "Ezomebaru" (*Sebastes taczanowskii*), and oral traditions of fishermen mention a place near the bank at which the waves in a stormy weather are broken with white horses. The author has had a question in his mind about the position of the shallowest part of the bank (rock reef), 10 meters deep, as described in chart No. 41 published by the Hydrographical Department, so he has made investigations to ascertain its position as well as to clarify the shape of the sea-bottom and the kind of creatures living there.

2) According to the observation by a deep sea diver, the underwater reef in the depth of 10 meters is a rocky material about 90 meters in length from south to north, and about 60 meters in width from east to west. On that reef stands a rock, about 1 meter in diameter and about 1 meter in height, which is visible from the ship; it was estimated by the author to be narrower than was observed by the diver.

Fig. 15 is a reproduction of an echo sounding photograph taken when the shallowest part 10 meters deep was observed. The image of a sharp rock on the left hand of the photograph is recorded while sailing, and that on the right hand while the ship was resting just above the rock with the ship engine stopped.

Judging from the echo sounding records and the observation by the diver, the rock in the depth of 10 meters is surrounded by two to three steps of rocky beds going down to deeper water. The sea-bottom in the depth of 30~40 meters is a furrowed rocky reef with depressions and upheavals here and there. In the furrows are gathered shells and broken pieces of rock, the latter having changed to roundish gravels. According to the judgement of Prof. Yasuo Sasa of the Laboratory of Geology, Faculty of Science, Hokkaido University the rocky bottom consists of basalt, pyroxene andesite, liparite, diorite (or quartz diorite) and other andesite species. The lower part of the bank from near the level 40 meters deep spreads in all directions sloping gently.

Fig. 16 shows the echo sounding images recorded while a diver was collecting demersal creatures and the bottom material in the waters 20 meters deep surrounding the 10 meters deep reef; S, the images recorded when the diver was going down to the

bottom;  $S_1$ , the images recorded when he was collecting the samples on the bottom; and  $S_2$ , the images recorded when the diver was ascending to the surface from the bottom.

Fig. 17 shows the images recorded while an angling experiment was in progress for Atka mackerel (*Pleurogrammus azonus*) and 'Kitunemebaru', in the waters 40 meters

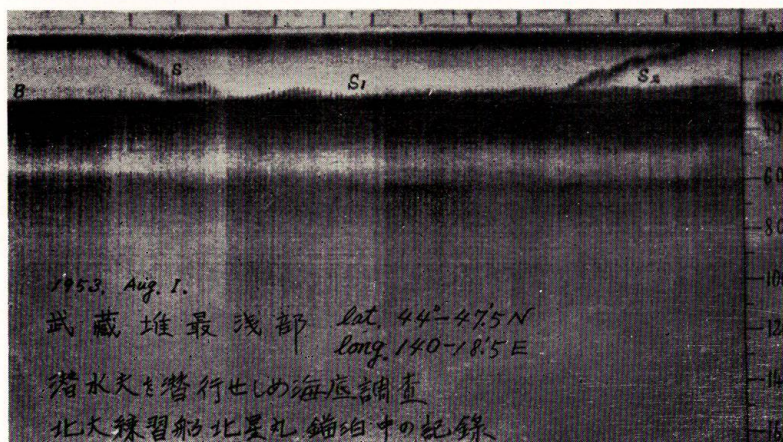

Fig. 16 Echo-image when marine creatures and bottom materials were being collected by a diver on the shallowest part of the Musashi Bank

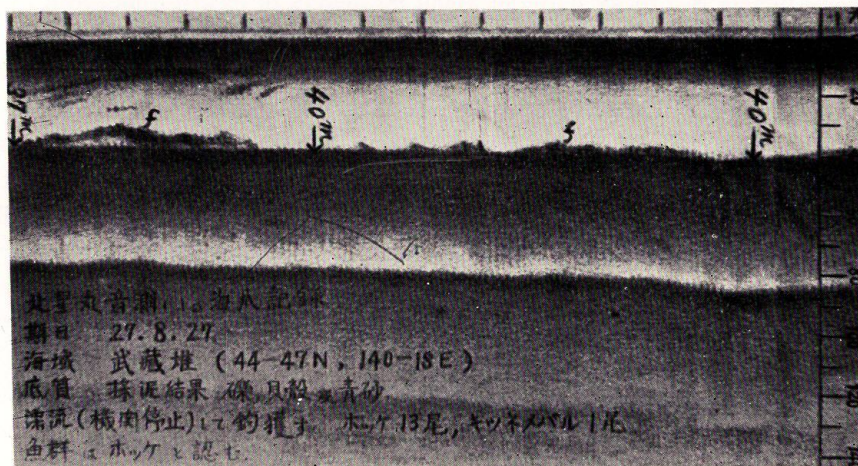

Fig. 17 Echo-image of the sea-bottom near shallowest part of the Musashi Bank when angle fishing test was made

deep where the bank begins to spread sloping gently in all directions: f, fish\_shoal. The image of the 2nd echo of the bottom is clearly recorded.

3) The demersal creatures collected were animals such as sea urchin (*Helicidaris crassispina*), starfish species, sea cucumber (*Stichopus japonicus*), and "Hiyorigai" (a shelf fish), and a seaweed named "Aname" (*Agarum cribrosum*). *Laminaria* and other



seaweeds were not found, and common abalone (*Haliotis gigantea*) which has been said to be present there was also absent. No fish other than "Kitsunemebaru" and "Ezomebaru" were angled.

4) As for the position of the underwater reef at the shallowest part of the bank, a continuous survey by celo-navigation made on August 27th 1953, on the ship anchored right above the reef, revealed that the position was lat.  $44^{\circ}47.9'N$ , long.  $140^{\circ}18.0'E$ . So the position of the reef at 10 meters depth which has hitherto been described on the chart No. 41 as lat.  $44^{\circ}47.4'N$ , long.  $140^{\circ}20.5'E$ , is separated from the aforementioned position by 1.8 nautical miles to the true bearings  $113^{\circ}$ .

(6) The range of waters which can be exploited as a trawl fishing ground

As stated previously by the author (1951), no marketable fish is found in the waters deeper than 400 meters in the sea northwest of Hokkaido. In surrounding waters near the Musashi Bank, the fact was observed. Therefore, the waters shallower than 400 meters must be taken into consideration as a trawl fishing ground. Whether a trawl fishing ground can exist or not of course depends on the sea depth, bottom material, velocity of tidal currents, and the presence or absence of marine creatures. In this range of waters, the effect of the tidal current velocity can be offset, so the bottom material and sea depth will be discussed here (Fig. 12).

As above stated, the part of Musashi Bank in the depth less than 200 meters is mostly rocky reef. The fact that the more shallow the sea-bottom, the more coarse the surface of the bank was ascertained by echo sounding, hand machine sounding, bottom sampling, diver's observation and experimental trawl fishing. Therefore, the experimental trawl netting was operated avoiding the places with evident obstacles, yet sometimes ended in an unexpected failure because of some insignificant obstacles on the sea-bottom.

Judging mainly from the results of echo soundings and fishing experiments. It is very difficult to operate trawl fishing well on the bank at a depth less than 200 meters, except in eastern and northeastern parts of the bank. The relation between the sea depth and the accidents because of bottom obstacles is shown in Table 3. During the fishing experiments repeated 46 times, the accidents which resulted in torn nets and cut towing ropes due to bottom obstacles occurred 9 times mostly in the depth less than 260 meters at places right above the bank and in the periphery south, southwest, west and north of the bank. The number of successful trawlings at 175~260 meters depth was 16, of which 80% were performed on the eastern part and the eastern periphery of the bank. Since these results were not obtained by the fishing operated evenly in the periphery of the bank, the author cannot say positively which places have few obstacles, but he could draw the following five conclusions from the bottom survey by echo sounding and the fishing experiment.

1) The southern, northern and eastern sides of the bank are sloping gentle. The

western side is narrow as it slopes comparatively steeply. Especially narrow is the northwestern side. However, the northern side of the bank which is covered with mud has scattered sharp rocks and so offers frequent obstacles to the fishing, as pointed out by Shirai and Imaizumi (1925~26); the southern projected part of the bank is also coarse on surface, so it cannot be said suitable for trawl fishery.

2) The surface of the bank at a depth less than 200 meters consists of a hard rock and is a little uneven: so it is unfit for the trawl fishery except near the 200 meters deep line at the eastern part.

3) In the water above 260~270 meters depth around the bank, even if the bottom material surveyed was consisting of sand or mud, the trawling sometimes encounters an unexpected obstacle. However, in deeper waters an accident resulting in torn nets is of seldom occurrence. The trawl fishing can be safely operated in the waters below 300 meters depth.

4) In the waters above 260 meters depth the area which is comparatively safe for trawling lies on the eastern side of the bank, *i.e.* the 180~200 meters deep layer right above the bank, including Musashi channel (so named provisionally by Shirai and Imaizumi, 1925) situated between the 200 meter line of the continental shelf and the bank.

5) In the southern, southwestern, western and northern peripheries of the bank, the sea bottom obstacles in water less than 260 meters deep sometimes cause damages to the net during trawling. Especially in the northern and southern parts of the bank precautions have to be taken against such damages.

In conclusion, the trawl fishing ground around the Musashi Bank must be selected on the eastern part of the bank and its surrounding waters and in the southwestern and western peripheries of the bank at the water area from 250 meters to 400 meters in depth.

(7) The distribution and the amount of catch of the marketable kinds of bottom fish

The fishing by trawl net on the Musashi Bank was almost impossible as already mentioned on account of rocks in the bottom, having been operated safely only once in the southeastern part and at 180~200 meters depth of the eastern and northeastern parts of the bank. The places suited for the trawl fishing ground except the eastern and northeastern parts are limited to waters deeper than 200 meters surrounding the bank. Therefore, the research on distribution of demersal fish has laid emphasis on comparatively deeper water layers, being carried out principally by experimental fishing with a trawl net and additionally by angling and diving only in the vicinity of the shallowest part of the bank. In the following paragraphs will be mentioned the horizontal and vertical distributions and the amount of catch of marketable fish according to the results obtained by experimental fishing.

## 1) Horizontal distribution and the amount of catch

The kind of fish which were caught by trawl net on Musashi Bank were as follows.

Japanese name (English name)	Scientific name
"Hatahata" (Sand fish)	<i>Arctoscopus japonicus</i> (STEMDACHNER)
"Hatsume"	<i>Sebastes owstoni</i> (JORDAN et THOMSON)
"Hokke" (Atka mackerel)	<i>Pleurogrammus azonus</i> JORDAN et METZ
"Hokkokuakaebi" (Prawn)	<i>Pandalus borealis</i> KROYER
"Toyamaebi" (Prawn)	<i>Pandalus hypsinotus</i> BRANDT
"Tokubire"	<i>Podothecus sachi</i> (JORDAN et SNYDER)
"Tako" (Octopus)	<i>Polyopus vulgaris</i> (LAMACK)
"Tsumagurokajika"	<i>Gymnocanthus herzensteini</i> JORDAN et STARKS
"Nagazuka"	<i>Dinogunellus grigorjewi</i> (HERZENSTEIN)
"Nametagarei" (Flounder)	<i>Microstomus kitaharas</i> JORDAN et STARKS
"Makasube" (Ray)	<i>Raja pulchra</i> LTU
"Madara" (Cod)	<i>Gadus macrocephalus</i> TILESTUS
"Ezomebaru"	<i>Sebastes tarzanowskii</i> (STEINDACHER)
"Urokomegarei"	<i>Acanthopsetta nadeshnyi</i> (SCHMIDT)
"Aburazame" (Dog fish)	<i>Squalus suckleyi</i> (JIRARO)
"Akagarei" (Flat-head flounder)	<i>Cynopsetta dubia</i> SCHMIDT
"Abachan"	<i>Crystallias matsushimae</i> JORDAN et SNYDER
"Kitsunemebaru"	<i>Sebastichthys vulpes</i> (STEINDACHER et DODERLEIN)
"Suketodara" (Alaska pollack)	<i>Theragra chalcogramma</i> (PALLAS)

Of the above listed species, the following were caught comparatively in abundance and were marketable, so they will be discussed below: cod, Alaska pollack, Atka mackerel, "Hatsume" (*Sebastes owstoni*), flat-head flounder and prawn (*Pandalus hypsinotus*).

## a) The shallowest part and vicinity

In waters around the rock at 10 meters depth and in the neighbouring waters 30 ~50 meters in depth, Atka mackerel, "Ezomebaru" or "Gaya" and "Kitsunemebaru" or "Mazoi" were caught by "Tenten-angling" and "Hikkake-angling". "Kitsunemebaru" weighed mostly from 1 to 1.3kg each (Fig. 17). "Hiyorigai" (a shell fish), species of sea urchin, species of starfish and sea cucumber were caught by the diver. "Aname" (*Agarum cribrosum*) was the only seaweed collected. Neither *Laminaria* nor other seaweeds were present. Common abalone also was not observed.

## b) Northern part

At a position about 5.5 nautical miles north from the edge of the bank, corresponding to about 200 meters depth water, a small amount of cod and Alaska pollack was caught on the bottom, 330 meters below the sea surface in 1949. When the vessel approached the bank, the echo sounding records showed the presence of the

Table 3. Results of fishing experiment

Date	No.	water area	Depth (m)	Bottom material	Bottom condition	Possible operation or not
Aug. '49	1	E	285	M. S	flat	○
	2	E	330	M. S	flat	○
	3	W	360	M. S	generally flat	○
Aug. '50	4	E	200	S. M	flat	○
	5	S	360	M	flat	○
	6	S	255	M. S	generally flat	○
7	E.bank	175	R. M	flat	○	
Feb. '51	8	S	265	S	flat	○
Apr. '51	9	S	330	M. S	gentle slope	○
	10	S.bank	220	M. S	gentle slope	×
May. '51	11	W	280	M	gentle slope	○
	12	E	330	M. S	flat	○
	13	S	290	M	flat	○
	14	S	290	M	slight slope	○
	15	E	230	M	flat	○
	16	E.bank	145	G. R	flat	×
	17	W	260	S. M	slight slope	×
July. '51	18	S	255	S. M	slight slope	○
	19	N	230	S. M	flat, slight convex	×
	20	E	230	M	flat	○
	21	S	396	M. S	slight slope	○
Oct. '51	22	W	280	S. M	slight slope	○
	23	W	330	M. S	slight slope	○
	24	W	255	S. M	generally flat	○
	25	W	265	S	slight slope	○
Aug. '52	26	W	350	S. M	flat	○
	27	S	260	R	uneven	×
	28	S	250	R	uneven	×
	29	E	210	M. S	flat	○
	30	W	280	M. S	gentle slope	○
Aug. '53	31	W	280	M. S	gentle slope	×
	32	W	280	S. M	generally flat	○
	33	W	300	S. M	slight slope	○
	34	W	310	S. M	slight slope	○
Aug. '54	35	W	245	M. S. R	flat	×
	36	S	270	S	slight slope	○
	37	S	210	M. S. R	generally flat	×
	38	S	300	M. S	flat	○
	39	E	210	M. S	flat	○
	40	E.bank	190	M. S	flat	○
	41	E	220	M. S	flat	○
	42	E	230	M. S	flat	○
	43	E.bank	220	M. S	flat	○
	44	E.bank	200	M. S	flat	○
	45	E.bank	190	M. S	flat	○
46	E.bank	190	M. S	flat	○	
Total catch	38 hauls	(Excepting 8 hauls of hitch described in the right column)				
Average catch	38 hauls					

1957]

## Saito : Trawl Fishing

on the Musashi Bank

Catches (unit: "Kan")							
Cod	Alaska pollack	Atka mackerel	"Hatsume"	Flat-head flounder	Shrimp & prawn	Others	Total catch
16.0	8.0			8.0		24.0	56.0
16.0	8.0			8.0		24.0	56.0
39.5	8.0			8.0	1.5		57.0
8.0	24.0	1.0	24.0	12.0		3.0	72.0
12.0	8.0			0.5	1.0	16.5	38.0
16.0	40.0	4.0	112.0	2.0		30.0	204.0
8.0	1.5	24.0	0.4	2.5		30.6	67.0
16.0	16.0		40.0			1.0	73.0
15.0	24.0			5.0	1.0	9.0	54.0
No catch because of hitch							
1.5	50.0	0.3			0.2	8.0	60.0
18.0				0.8	0.2	1.0	20.0
22.0	35.0				8.0	17.0	82.0
8.0	28.0			1.0	3.0	1.0	41.0
1.5	16.0		0.4	12.0	0.3	16.8	47.0
No catch because of hitch							
No catch because of hitch							
96.0	40.0	2.0	0.4	3.0		10.6	152.0
No catch because of hitch							
1.5	146.0	0.1	0.1	24.0		0.3	172.0
2.0	70.0		0.2	0.3	0.5	19.0	92.0
3.0	100.0	12.0			0.5	3.5	119.0
20.0	110.0		0.4		0.6	1.0	132.0
1.0	46.0						47.0
40.0	15.0		140.0	1.0	1.7	1.3	199.0
13.0	20.0			0.4	0.6		34.0
No catch because of hitch							
No catch because of hitch							
10.0	3.0	2.0		7.0		9.0	31.0
	40.0						40.0
1.0	1.0		4.0	1.0	0.2	24.8	32.0
13.0	13.5	0.1	21.0	1.5		7.9	57.0
3.5	1.0		142.0	1.0		2.5	150.0
7.0	23.0	0.1	16.0	6.0	6.0	10.9	69.0
No catch because of hitch							
16.0	50.0	0.1	1.5		3.0	17.0	87.6
No catch because of hitch							
7.0	50.0	0.2	1.0	3.0	2.0	9.2	72.2
4.0	8.0	8.0		32.0		1.0	53.0
6.0		108.0		6.0		12.0	132.0
2.0		8.0		24.0		5.0	39.0
8.0	6.0	30.0	28.0	24.0		8.0	104.0
5.0	2.0	98.0	2.0	7.0		12.0	126.0
8.0	2.0	18.0		40.0		13.5	81.5
	4.0	120.0	4.0	12.0		2.0	142.0
6.0	1.0	145.0	5.0	3.0		4.0	164.0
470.5	1018.0	580.6	542.7	256.0	30.0	356.2	3254.3
12.4	26.8	15.3	14.3	6.7	0.8	9.2	85.6

rocky reef.

At a depth of 230~250 meters, the catch was sometimes null in 1951 on account of the hitch of the net on the sea-bottom obstacles. However, taking into consideration the result of angling experiment by Shirai and Imaizumi, the presence of fish such as cod, Alaska pollack, flat-head flounder and 'Kitsunemebaru' in that area seems unquestionable.

c) Eastern part (Table 4, Fig. 18 a~g)

The surface of the bank and its periphery is flat with few obstacles such as rocky reefs and underwater rocks. Those areas are thus the most easy place for operating fishing on Musashi Bank. Atka mackerel, Alaska pollack, cod, flat-head flounder, sand fish and "Nametagarei" (*Microstomus kittcharas*) are found living there. In summer,

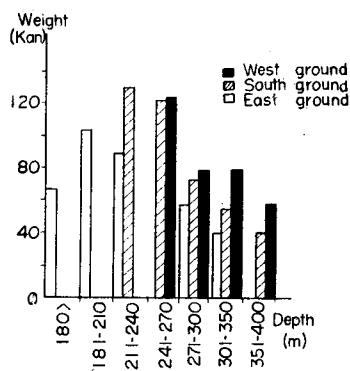

a

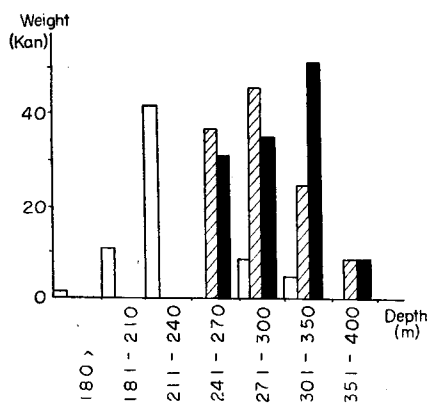

c

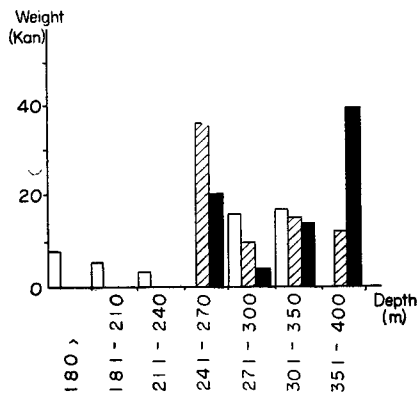

b

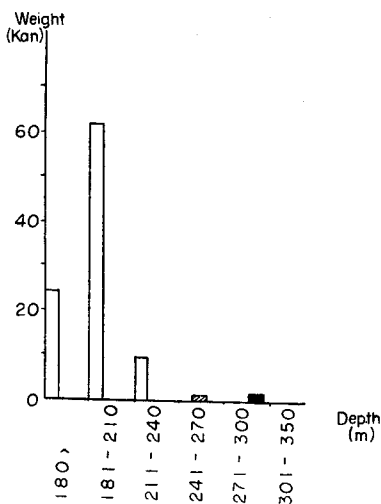

d

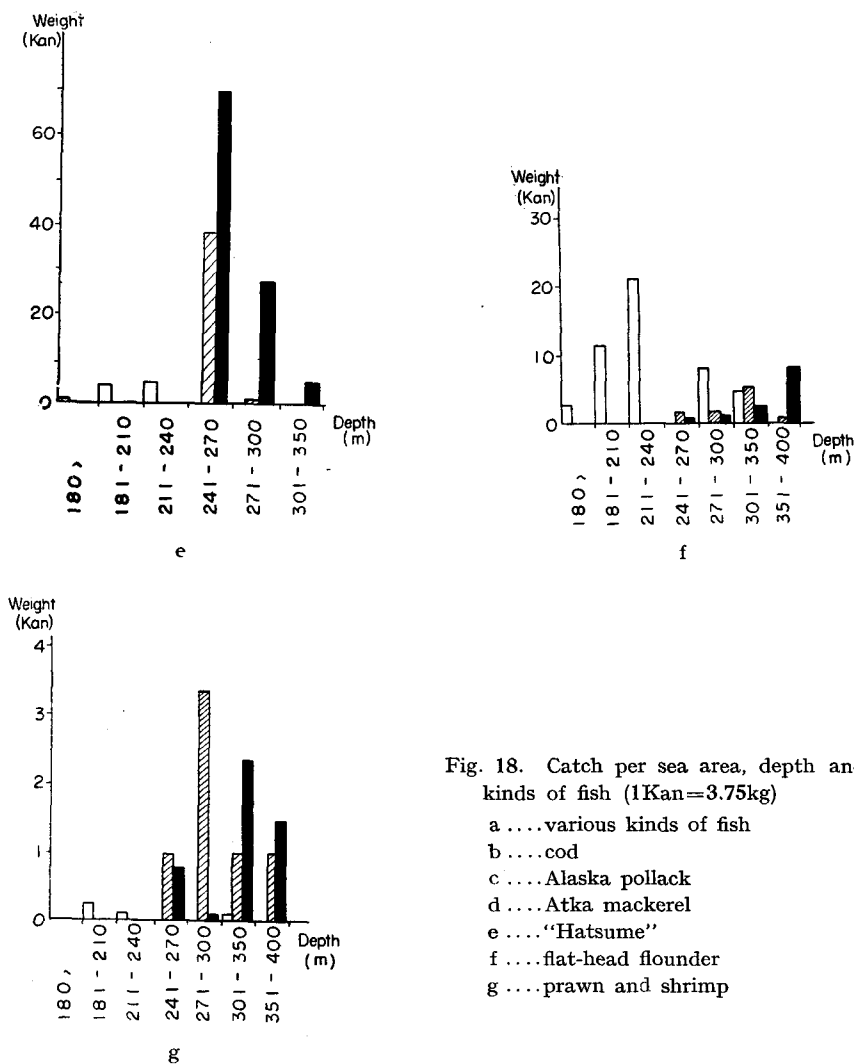

Fig. 18. Catch per sea area, depth and kinds of fish (1Kan=3.75kg)

- a...various kinds of fish  
 b...cod  
 c...Alaska pollack  
 d...Atka mackerel  
 e...'Hatsume'  
 f...flat-head flounder  
 g...prawn and shrimp

the waters 180~200 meters in depth on the bank gave a catch of Atka mackerel as much as 375 kg per one operation on the average. In waters 210~240 meters deep around the bank, the catch of Atka mackerel decreased, while the catch of flat-head flounder increased. In May, the catch of Alaska pollack and flat-head flounder was good in waters 240 meters deep around the bank.

d) Southern part (Table 4, Fig. 18 a~g)

Even in waters 260 meters in depth, the net often hitches on the sea-bottom obstacles, but it can be safely operated in waters about 300 meters in depth, and 'Hatsume', cod, Alaska pollack and flat-head flounder are the principal fish that

Table 4. Horizontal distribution of demersal fish

Mutsashi Bank	No. of operations	Catch (unit : 1 Kan=3.75 kg)								Total	%
		Cod	Alaska pollack	Atka mackerel	'Hatsume'	Flat-head flounder	Shrimp & prawn	others			
East*	16	7.5	14.3	35.1	3.9	13.9		10.7	85.4	33.1	
South**	10	21.0	36.1	0.6	15.5	1.5	1.9	13.0	89.6	34.7	
West***	12	11.9	35.6	1.0	27.0	1.6	0.9	5.0	83.0	32.2	
Total	38	40.0	86.0	36.7	46.0	17.0	2.8	28.0	258.0	100.0	

## Remarks

\* One haul could not be made on account of hitch on a rock besides 16 hauls described

\*\* Four hauls impossible on account of hitch on a rock besides 10 hauls described

\*\*\* Two hauls impossible on account of hitch on a rock besides 12 hauls described

Table 5. Vertical distribution of marketable demersal fish

Depth (m)	No. of times	Serial no. of operations	Catch (unit : 1 Kan=3.75 kg)								Total	%
			Cod	Alaska pollack	Atka mackerel	'Hatsume'	Flat-head flounder	Shrimp & prawn	Others			
180>	1	7	8.0	1.5	24.0	0.4	2.5		30.6	67.0	11.8	
181-210	8	4, 29, 39, 40, 43, 44, 45, 46	5.9	5.5	62.5	4.4	14.9		7.1	100.3	17.7	
211-240	4	15, 20, 41, 42	3.3	42.0	9.5	7.0	21.5	0.1	7.3	90.7	16.0	
241-270	6	6, 8, 18, 24, 25, 36	30.8	34.5	1.0	48.9	1.0	1.1	10.0	127.2	22.5	
271-300	11	1, 11, 13, 14, 21, 22, 30, 31, 32, 33, 38	7.0	36.1	1.1	15.3	1.4	1.3	10.6	72.8	12.9	
301-350	6	2, 9, 12, 23, 26, 34	14.8	30.8		2.7	3.4	1.4	7.7	60.8	10.7	
351-400	2	3, 5	25.6	8.0			4.3	1.3	8.3	47.5	8.4	
Total	38		95.4	158.4	98.1	78.7	49.0	5.1	81.6	566.3	100.0	

can be caught. In waters below the depth of 300 meters, prawns (*Pandalus hypsinotus*) were pretty abundant. The record of catch in summer was better than in winter.

e) Western part (Table 4, Fig. 18 a~g)

In this part, the main catch by trawling were cod, Alaska pollack, flat-head flounder, "Hatsume" and prawn. The range of waters suited for a fishing ground is not large, but it is easy to operate fishing there. In summer, the catch of cod and "Hatsume" by net may be good.

f) Relation between the bottom water temperature and the amount of catch

The relation between the water temperature and the amount of catch is not so significant in the demersal fish as it is in the migratory fish. However, in considering the relation between the bottom water temperature and the amount of catch observed during the fishing experiments carried out from 1950 to 1953 the following comment may be given here (Table 6).



Table 6. Relation between the botom sea temp. and the amount of catch

Date	Area	Depth (m)	Temperature of near botom (C)	Catch (unit : 1Kan=3.75 kg)	Remarks
May. '51	S	225	4.0	156	
	N	230	2.3	×	
	E	230	2.8	172	Alaska Pollack
July. '51	S	296	3.5	92	"
	W	280	3.1	119	"
	W	330	4.3	132	"
Oct. '51	W	255	4.6	47	
	W	265	4.2	199	"Hatsume", Cod
	W	350	4.8	34	
	S	250	6.2	×	
Aug. '51	E	210	5.3	31	
	W	280	1.6	40	
Aug. '51	W	280	1.5	32	
	W	280	1.3	57	
Aug. '51	W	310	1.4	69	
	S	210	3.2	×	
	E	210	2.5	53	

In waters 200~350 meters in depth, when the water temperature was 2.8°~4.3°C, the amount of catch was more than 375 kg per one operation. The catch of Alaska pollack, cod, and "Hatsume" was good at about 4°C, while it was poor below 2°C. From May to October, the bottom water temperature was in the range from 1.3° to 6.2°C, showing some fluctuation by month and year. It may be remarkably low in some years, for example, in 1952, it was 1.3°~1.5°C even in August. However, the bottom water temperature does not show any marked regular seasonal change as the surface water temperature does.

In short, the important fish in the waters around the Musashi Bank such as cod, Alaska pollack, Atka mackerel, "Hatsume", flat-head flounder and prawn (*Pandalus hypsinotus*) were uniformly present in all water areas, but not in even amount from the view point of fishery resource. The results of fishing experiments, show that the kinds of fish abundantly caught from the shallowest, eastern, southern and western parts of Musashi Bank are as follows. In the shallowest part, "Kitsunemebaru", "Ezomebaru" and Atka mackerel were abundantly caught. In waters above 200 meters deep level at the eastern part of the bank, Atka mackerel was mainly caught. With the increase of depth, the catch of flat-head flounder and Alaska pollack became more abundant. In the southern periphery of the bank, the fish abundantly caught were cod, Alaska pollack and "Hatsume", and in the western periphery, they were Alaska pollack and cod. In both southern and western parts of the bank, with the approach to the 200 meters deep line the catch of Atka mackerel and "Hatsume" increased.

The total amounts of catch in each of three water ranges at the eastern, southern and western parts of the bank are similar to each other as shown in Table 4. In the amount of total catch per one kind of important fish, Alaska pollack occupies 33% of

the grand total, while Atka mackerel, "Hatsume" and cod are similar to each other occupying 14~17%. Alaska pollack stands atop in the amount of the catch. However, it must be kept in mind that those amounts are not the result obtained from the same depth of water and that the conditions of each water area differ from each other.

The value of a fishing ground should be determined by the quantity of marketable fish. From this point of view, on Mushasi Bank, importance should be attached to the eastern ground where Atka mackerel and flat-head flounder can be caught abundantly. Ninety-five and 82% of the total amounts respectively of Atka mackerel and flat-head flounder from the three water ranges were caught at the eastern water range or ground. The relation between the amount of catch and the water depth as well as the kind of fish at each water range will be discussed below.

2) Vertical distribution of fish and the amount of catch

It is difficult to draw any simple conclusion regarding the vertical distribution of fish in the waters around Musashi Bank from the results of the experimental fishing which were operated only 38 times in all, under different conditions of the shape and material of the sea-bottom, and of oceanographical and meteorological factors and moreover in different hours of a day. However, it may be possible to formulate general views as follows on the vertical living layers of various kinds of fish at which a good catch of fish can be obtained, on the basis of the amount of catch at each

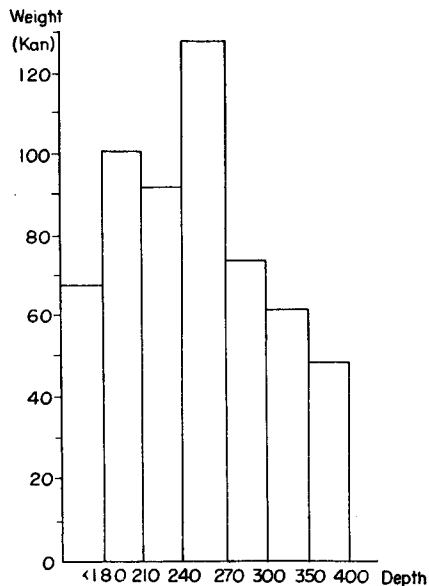

a

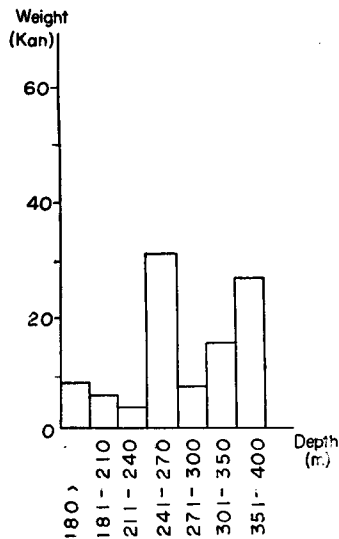

b

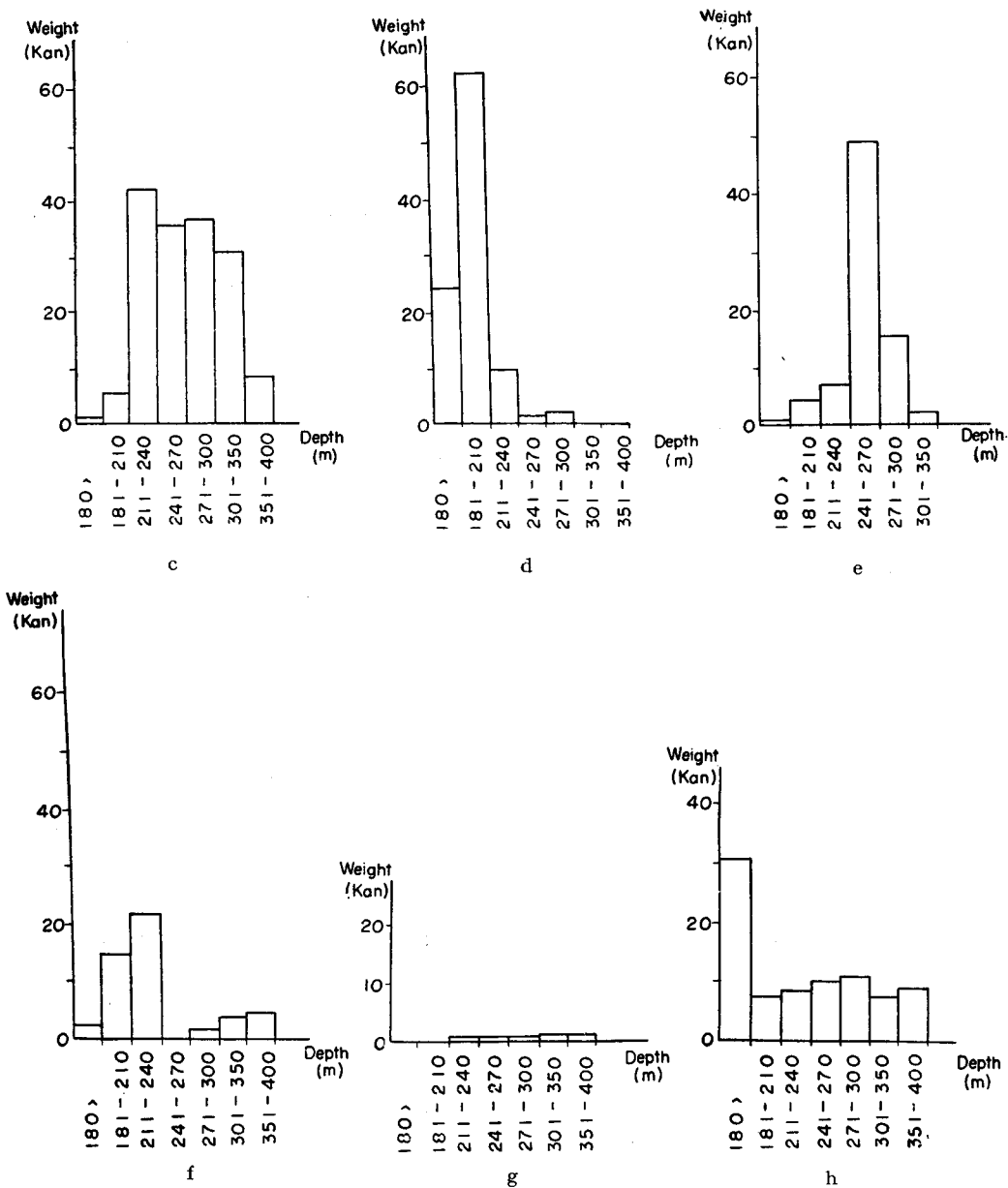

Fig. 19 Amount of catch and kinds of fish according to depth

- a ....catch of total kinds of fish per depth
- b ....cod
- c ....Alaska pollack
- d ....Atka mackerel
- e ...."Hatsume"
- f ....flat-head flounder
- g ....prawn and shrimp
- h ....other fishes

depth in the eastern, southern and western water areas of Musashi Bank.

a) The amount of catch at each depth in the surrounding waters. Vertical distribution of total amount of catch including cod, Alaska pollack, Atka mackerel, "Hatsume", flat-head flounder and prawn is shown in Fig. 19 a~h.

At 240~270 meters depth the amount of catch was largest (22.5%). The depth of 180~240 meters stands next in the catch (16~17.7%). Below 270 meters depth the catch diminished with the increasing of the depth. According to the results of the author's investigation on the vertical distribution of fish in all the sea area northwest of Hokkaido carried out from 1949 to 1950, the amount of catch as well as the number fish species was largest near the 200 meter line, while in waters around Musashi Bank, it was largest in somewhat deeper waters.

This discrepancy may be due to the effect of the bottom material, sea conditions and natural foods for fish. However, it may be also due to the fact that a thorough investigation could not be carried out on account of the difficulty in towing net at a depth less than 200 meters because of the obstacles on the sea-bottom.

Table 7. Vertical distribution in each water area

Area	Depth (m)	No. of operations	Catch (unit : 1 Kan=3.75 kg)								Total	%
			Cod	Alaska pollack	Atka mackerel	"Hatsume"	Flat-head flounder	Shrimp & prawn	Others			
East	180> <sup>(1)</sup>	1	8.0	1.5	24.0	0.4	2.5			30.6	67.0	19.0
	181-210 <sup>(2)</sup>	8	5.9	10.8	61.5	4.5	11.1	0.3	8.1	102.2	29.0	
	211-240	4	3.2	42.0	9.5	5.4	21.1	0.1	7.5	88.7	25.1	
	241-270											
	271-300	1	16.0	8.0			8.0		24.0	56.0	15.9	
	301-350	2	17.0	4.0			4.4	0.1	12.5	38.0	11.0	
South	180>											
	181-210 <sup>(3)</sup>											
	211-240 <sup>(4)</sup>	1										
	241-270	3	36.0	36.7	1.6	38.5	1.2	1.0	14.7	129.2	44.1	
	271-300	4	9.5	45.7		0.3	1.1	3.4	11.5	71.5	24.4	
	301-350	1	15.0	24.0			5.0	1.0	9.0	54.0	18.5	
West	351-400	1	12.0	8.0			0.5	1.0	16.5	38.0	13.0	
	180>											
	181-210 <sup>(5)</sup>											
	211-240											
	241-270 <sup>(6)</sup>	2	20.5	30.5		70.0	0.5	0.8	0.7	123.0	36.8	
	271-300	5	3.7	34.3	2.0	27.9	0.6	0.1	7.8	76.4	22.8	
301-350	3	13.3	51.0		5.5	2.1	2.4	3.8	78.1	23.4		
351-400	1	39.5	8.0			8.0	1.5		57.0	17.0		

## Remarks

- (1) One haul could not be made on account of hitch on rock besides 1 haul
- (2) No catch on account of hitch
- (3) One haul could not be made on account of hitch on rock besides 1 haul
- (4) Two hauls could not be made on account of hitch on rock besides 3 hauls
- (5) No catch on account of hitch
- (6) Two hauls could not be made on account of hitch on rock besides 2 hauls

## b) The amount of catch at each water area and water depth

*Eastern ground*

On the eastern ground, the water layer at 180~210 meters depth yielded the largest amount of catch, being 352.5 kg on an average per each operation. This amount corresponds to 29% of the total amount of catch at the water layer 180~350 meters in depth. The layer at 210~240 meters depth comes next in the catch which corresponds to 25% of the total. The amounts of catch above 180 meters depth and below 270 meters depth diminished abruptly (Table 7; Fig. 18 a).

With respect to the kind of fish caught, Atka mackerel stands atop in the amount of catch, being abundantly caught at 180~210 meters depth. Alaska pollack and flat-head flounder are almost equal in the amount of catch, being caught at 210~240 meters depth. This area corresponds to the Musashi channel, as named provisionally by Shirai and Imaizumi, which is situated between the 200 meter line of Musashi Bank and the 200 meter line of the continental shelf.

*Southern ground*

The amount of catch at each depth from southern water area around Musashi Bank is shown in Table 7 and Fig. 18 a~g.

At 180~240 meters depth, there were so many obstacles on the bottom that the trawling was difficult to operate. So the experimental fishing was operated mainly at the depth of 240~400 meters. As a result, the amount of catch at 240~270 meters depth was largest (44% of the total); "Hatsume", Alaska pollack and cod were caught in nearly equal amount at this depth. The water layer 270~300 meters in depth ranks next in yield (24.4%); Alaska pollack was the principal take in this layer, the amount of which was larger than in the water above 270 meters depth. On the contrary, the catch of cod diminished abruptly in that layer. In other words, the inhabiting depth of cod appears to be somewhat shallower than that of Alaska pollack. The catch of "Hatsume" decreased markedly in the water below 270 meters depth, and almost disappeared below 300 meters depth.

*Western ground*

In the western water area too, the sea-bottom at a depth less than 240 meters has so many rocky reefs that net-towing was difficult. Therefore, the results presented here were obtained at the depth below 240 meters. The amount of catch was largest at the depth of 240~270 meters (Table 7; Fig. 18 a~g). At 270~350 meters depth, the amounts of catch at each depth were almost equal to each other. Below 350 meters depth, the catch became poor. "Hatsume", Alaska pollack and cod were caught in large amount, of which "Hatsume" was living in the shallowest layer up to about 270 meters in depth, Alaska pollack was widely distributed in the range of water 240~350 meters in depth, and cod was similar to Alaska pollack.

## c) Monthly amount of the catch

As has already been mentioned, the investigations of the Musashi Bank herein described were mostly carried out in summer (July~August), but only occasionally in February, April, May and October. So it is not possible to make a conclusive remark on the seasonal change of the amount of catch. However, the author believes it may be possible to surmise a general fluctuation in the amount of the important fish around the bank. As shown in Table 8, the average amount of catch per one operation is largest in May (21% of the total). Next comes the catch in each of the three months, July, August and October, which are similar in catch to each other. The amount of catch in February, through based on only a single operation on account of a miss in net-towing, is almost equal to that in July. It was least in April, being only 9.5% of the total. The seasonal change in catch of each kind of fish is as follows.

Table 8. Monthly catch on Musashi Bank

Month	No. of operations	Catch (unit : 1 Kan=3.75 kg)								Total	%
		Cod	Alaska pollack	Atka mackerel	"Hatsume"	Flat-head flounder	Shrimp & prawn	Others			
2	1	16.0	16.0		40.0			1.0	73.0	15.6	
4	3	11.5	24.7		0.1	1.9	0.5	6.0	44.7	9.5	
5	5	25.8	53.2	0.4	0.2	8.0	2.3	9.1	99.0	21.1	
7	4	5.2	65.2	3.0	1.2	0.1	0.3	4.7	79.7	17.0	
8	22	9.2	13.6	25.7	14.6	9.1	0.6	11.7	84.5	18.0	
10	3	21.0	12.7	0.7	46.6	2.8	0.8	3.4	88.0	18.8	

Cod was caught abundantly in May and October, but the catch was poor in summer. It is in May that cod disappears from the coastal waters of Hokkaido and this may be considered to have some connection with the catch in waters around Musashi Bank.

Alaska pollack was caught in every month as was cod; the catch in May and July was largest. However, the amount of catch depends on the depth of operation, so even in August when the catch was poor the resources of this kind of fish cannot be judged to be scarce.

Atka mackerel lives in water less than 200 meters deep, but it was so difficult to operate fishing gears at that depth of the bank that the amount of its resources cannot be surmised simply from the results of the experimental fishing. Atka mackerel which was caught in the eastern area of Musashi Bank was of small size, the so-called "Rōsoku-hokke" that means the slim Atka mackerel, while that which was caught in the same season in water south of Teuri Island near the 200 meter line was larger in size.

"Hatsume" was caught in considerable amounts in February and October, while

its catch was small from April to July. Likewise, no exact comment on its resources can be made on account of the limitation of the water depth in which the fishing was operated, but this fish seems to accumulate more abundantly in autumn and winter than in mid summer. As for flat-head flounder and prawn (*Pandalus hypsinotus*), it will be only suggested here that they were caught during the whole year.

(8) Musashi Bank as a trawl fishing ground

In respect to the bottom material and depth, the fishing ground on and around the Musashi Bank may be described as follows. The northern part of the bank has many rocky obstacles on the bottom in spite of its being composed principally of deep mud, and in addition, the catch is poor, so that it falls short of expectation.

The eastern area of the bank including "Tengu no hana", that means "Nose of the goblin", can be trawled at the 200 meter line and even above that line, with the catch composed principally of Atka mackerel and including flat-head flounder. So this is a promising area where the trawling can be operated most safely among the areas on and around the bank (Fig. 20).

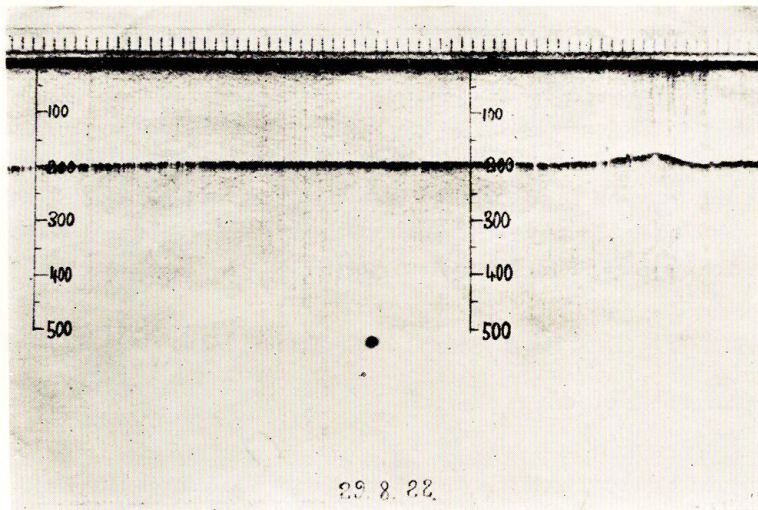

Fig. 20. Echo-image of the bottom of the 200 m line on the eastern part of the Musashi Bank

At 210~240 meters depth, the catch of flat-head flounder increases, while that of Atka mackerel decreases. The fishing ground of this area should be aimed at first of all in case the vicinity of Musashi Bank is exploited.

The southern part of the bank is rich in catch of fish at 240~270 meters depth as already mentioned. However, the fish that can be caught here are such as cod, Alaska pollack and "Hastume" which have comparatively lower market value. Furthermore, there is a fear of breaking the net by its being caught by the obstacles on the bottom.

The shoal of cod contains fat adults of larger type, but a majority of the cod as well as of Alaska pollack are rather young. On the contrary, "Hatsume" is of larger type and its amount of catch is large. However, as stated above, the fish in this area are generally inferior in quality to those found in the eastern fishing ground. The nets can be operated safely at this area if towed on the bottom below 300 meters depth.

The western area of the bank seems to resemble the southern area in the condition of sea bottom regarding the fishing operation and in the distribution of fish. However, "Hatsume" is more abundant than in the southern area; the center of the depth at which cod and Alaska pollack are caught is in somewhat deeper layers, *viz.*, it is at 350~400 meters depth for cod, and 300~350 meters depth for Alaska pollack. A good catch of prawn (*Pandalus hypsinotus*) can be made at 270~350 meters depth in both southern and western areas.

In the shallowest part of bank, any good catch of marine creatures other than fish can not be expected. "Kitsunemebaru" or "Soi", "Ezomebaru" or "Gaya", and Atka mackerel can be caught by angling. However, the small fishing boats which are to be engaged in angling cannot expect to find a good field of activity in this area, in view of the fairly rapid tidal current prevailing and also of the long distance from their home ports.

In short, the most promising area as a trawl fishing ground is the eastern part of Musashi Bank and its surrounding waters, while in the western and southern parts of the bank the trawling is possible to operate only in the peripheral water areas but not on the very bank. The western and southern parts of the bank are inferior in nature as a fishing ground to the eastern part.

### III. STUDIES ON THE FISHING GEARS OF THE TRAWL FISHERY

#### I. Improvement of the net

##### (1) Introductory remarks

In the trawl fishery which has been operated in the sea off Hokkaido, in spite of the tendency to adopt larger and more efficient ships and engines, the net used as the principal fishing gear is still made of conventional cotton twine and its shape and structure remain in many respects unchanged from the former type of the days of "Okiteguri-ami" (a kind of small trawl). At the height of the fishing season of Alaska pollack, Atka mackerel and dog fish (*Squalus suckleyi*), very dense shoals of these fish come to the fishing grounds under consideration, and the amount of catch per one haul sometimes proves to be enormous in quantity, so that the loss of nets becomes remarkable, and sometimes even new nets are broken on account of overfishing.

For a counterplan there are conceivable the employment of thick cotton twine or the reinforcement of the easily breakable parts of the net. However, a basic





from 1952 to 1954 on the effect of the use of this net upon the fishing operation and on the catch as compared with conventional cotton nets. The results proved the superiority of the net designed by the author; it will be described below.

A. The New "25-Nen" Style (1950) Manila Twine Net (Fig. 21)

*Characteristics of the net :*

The new net was designed by combining features of the type of otter trawl net with those of the conventional trawl net. It has several characteristics as follows.

- 1) Net was made of manila twine weighing 3.8 g per 165 cm, and the cod end was also made of manila twine weighing 4.9 g; the material was dyed with coal tar.
- 2) The meshes of the side parts of the net ("Waki-ami") were decreased in number gradually to the cod end or bag net. The cod end consists of only back and belly without side parts of the net.
- 3) Flapper ("Kaeshi-ami") was attached to the net.
- 4) Head-rope ("Fushi-zuna") and lacing line ("Suji-nawa") were made of a wire rope served with tarred manila twine.
- 5) Ground-rope ("Chinshi-zuna") was also made of wire rope packed with old netting and wound with tarred rope at equal intervals (Fig. 22, C); porcelain sinkers were not employed.

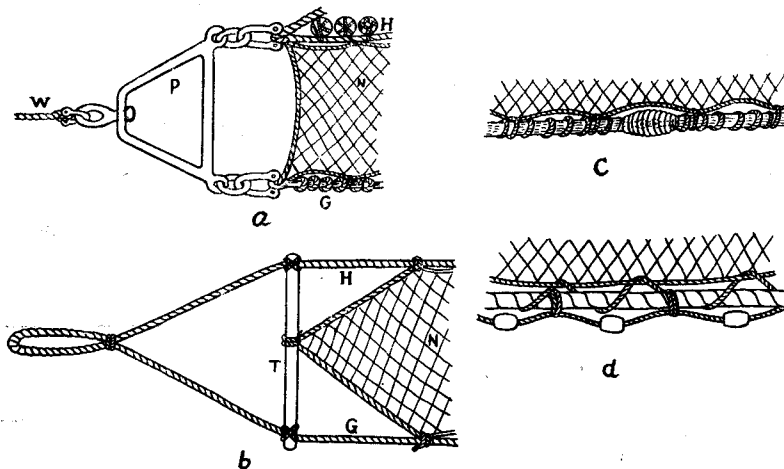

Fig. 22. Formation of ground rope, and pendant swivel

6) To facilitate the taking out of the catch from the cod end ("Fukuro-ami"), its terminal was bound with cod line, which can be easily untied from outside as in the otter trawl net.

7) In order to increase the effect of the swivel of the whole net, and to promote the sinking velocity, an iron pendant swivel was attached to each fore edge of the nets

in place of the usual wooden pole or "Tegi".

8) Since the mouth of the usual cotton trawl net was generally narrow the next measures were taken. The head line of the mouth was elongated to 9 meters from the usual length of 2.3 meters, and the foot line of the mouth to 5 meters from the usual length of 1.5 meters. As a result, the circumference near the mouth of net was enlarged to be almost doubled.

9) The length of the square part ("Tenjō-ami") of the improved net was increased to 2.3 meters from about 1.5 meters of the usual cotton net.

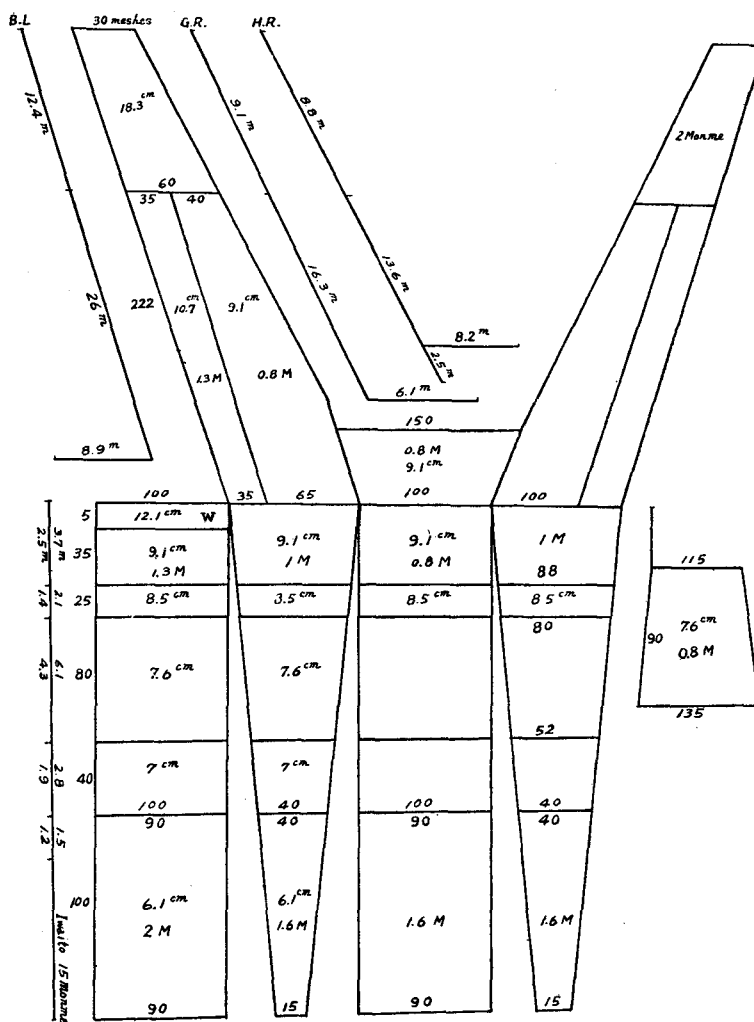

Fig. 23. A plan of new type manila twine trawl net of "27-Nen" type

Structure of the net :

The structure of the new style net and of its appurtenances, as well as its catching efficiency, have been reported in detail in the Reports of the Research Association of Deep Sea Fishing Ground in the Northern Japan Sea, No. 2. Since this new net proved too heavy for a fishing boat of 104 gross tons and 210 indicated horsepower, the wing nets and flapper were cut down to decrease the resistance of water, and the ground rope was thinned to decrease its weight.

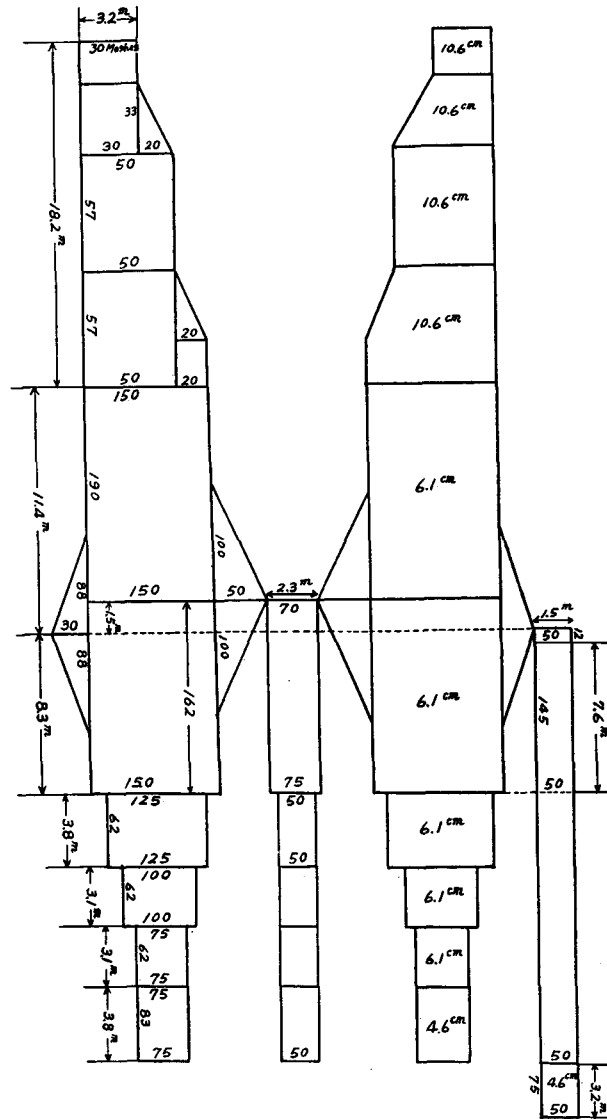

Fig. 24. A plan of usual cotton twine trawl net (an example)

A comparative experimental fishing with the new style net and the usual cotton twine net was carried out. As a result, the catch of the fish living near the sea-bottom by means of the former was 1.7 times as much, and the total amount of catch including bottom fish by means of the former was 1.5 times as much as usual (cf. Reports of The Research Association of Deep Sea Fishing Ground in the Northern Japan Sea, No. 2, pp. 43~51).

#### B. The Improved "27-Nen" Style (1952) Manila Twine Net (Fig. 23)

The author has ascertained that the "25-Nen" Style Manila Twine Net was superior to the hitherto generally used cotton twine net in catching efficiency. However, the "25-Nen" Style Net was still in need of improvement in shape of net, in structure of various parts of the gear and in the thickness of twine. So, in 1952, the author designed again a lighter and more handy manila twine net ("27-Nen" Style Manila Twine Net). As a result of experimental fishing operated in several successive years, this net proved superior in every respect to the "25-Nen" Style Net, and the author has been convinced that this net is an ideal gear to be operated in the fishing grounds in the waters around Hokkaido and in the Northern waters or "Hokuyo", where the catch per one operation is usually very large.

Structure of the fishing gear :

#### *Parts of net*

The structure of each part of the net is shown in Table 9.

Table 9. Structure of "27-Nen" Style Manila Twine Net (cf. Fig. 23)

No.	Part names of the net	Material	Twine size (gr. per 165 cm)	Mesh size (cm)	No. of mesh	Net length (m)	
1	Large mesh wings ("Arate-ami")	manila twine	7.5	18	60/30	14.6	
2	Upper wings ("Uwasode-ami")	"	2.4	9.1	65/65	3.6	
				9.1	65/40	20.2	
3	Lower wings ("Shitasode-ami")	"	4.9	10.7	35/35	23.8	
4	Square part ("Tenjō-ami")	"	2.4	9.1	150/100	3.2	
5	Baiting ("Se-ami")	"	2.4	9.1	100/100	3.6	
				"	8.5	"	2.1
				"	7.6	"	6.1
				"	7.0	"	2.8
6	Belly ("Hara-ami")	"	4.9 double	12.1	100/100	0.6	
			4.9 single	9.1	"	3.0	
			"	8.5	"	2.1	
			"	7.6	"	6.1	
			"	7.0	"	2.8	
7	Side net ("Waki-ami")	"	3.8	9.1	100/88	3.6	
				"	8.5	88/80	2.1
				"	7.6	80/52	6.1
				"	7.0	52/40	2.8
	Side net of cod end	"	6	6.1	40/15	6.1	

8	Flupper or non-return valve net ("Kaeshi-ami")	manila twine	2.4	7.6	135/115	6.8
9	Cod end ("Fukuro-ami")	"	7.5	6.1	90/90	6.1

### **Rope Parts**

1) The head-rope is a wire rope 0.9 cm in diameter. The rope was marled with marline. The large mesh wing is 8.8 meters long, the wing net 13.6 meters long, and the middle part (the fore edge of the square net) 8.2 meters long. At each end of the ropes an eyelet is made through which a heart thimble is fixed, and the two ends are shackled. The total length of the head-rope is 53 meters.

#### 2) Ground-rope

The ground-rope is constructed first by packing a core of wire rope 1.5 cm in diameter with old netting or similar substance, and then the whole is wound with tarred rope which is 0.9 cm in diameter or with soft twisted manila rope at equal intervals (cf. Fig. 22, C).

The ground-rope consists of five portions — a bosom (middle part), two wings and two large mesh wings. The total length is 57 meters. The lengths of portions are as follows: bosom (middle part) 6.1 meters, each wing 16.3 meters, each large mesh wing 9.1 meters. The joints of each portion are shackled up and are packed with tarred rope.

#### 3) Bolch line

This line is made of manila twine weighing "15-Monme" (60 grams per 165 cm), and is 74.5 meters in length. The lengths of the portions are as follows: bosom (middle part) 8.5 meters, each wing 20.6 meters, each large mesh wing 12.4 meters. Those lines are attached to each portion of the ground-rope, 6.1 meters, 16.3 meters and 9.1 meters long respectively.

#### 4) Lacing line

For making lacing line four ropes were employed as four angles of the body net, *i.e.*, upper, lower left and right angle, as in the usual cotton twine net. The lacing line is made of wire rope 9 mm in diameter, which is served with a marline. Each line is 11.2 meters long, to which the body net, which is 16.1 meters long, is fixed.

#### 5) Cod line

The cod line has not been used in the usual cotton twine net. This is a tarred rope 12 mm in diameter, and ties up the terminal of the cod end from which the catch is taken out. A special tying method is used here as in the otter trawl net so that the line will not be untied by inner pressure of the catch, but easily by hand from outside.

#### 6) Quarter-rope

This is the rope by which the body net mouth is closed and the heavily loaded

cod end is drawn to the bulwark rail when the net is being hauled onto the ship. By employing this rope, as is the case with the otter trawl net, the net can be quickly hauled onto the ship by mechanical power saving human power. This rope is made of manila twine rope 18 mm in diameter. It has not been used in the usual cotton twine net.

#### Appurtenances :

##### 1) Net float

For net floats, glass balls 15 cm diam. are used. They are attached to various portions of the head ropes as follows :

To the ends of the large mesh wing, at intervals of 30 cm, .....	8	balls
To the middle part, at 60 cm intervals .....	12	"
To the conjugating line of the square net .....	8	"
To other parts, at 75 cm intervals .....	59	"
	Total	87 "

##### 2) Pendant swivel

In the usual net, a wooden pole or "Tegi" has been used. In the improved net, iron pendant swivels are used as in the otter trawl net (Fig. 22, a). This seems to quicken the sinking velocity of the net, untwist the twist of the fishing gear, and generate a muddy screen which is effective in frightening fish during net towing.

##### (3) Discussion

The results of comparative fishing experiments by the New "25-Nen" Style manila twine net and the usual cotton twine net have already been published in 1951 (Reports of the Research Association of the Deep Sea Fishing Ground of Northern Japan Sea, No. 2). According to the results, the catch by the former net of the fish living near the sea bottom such as cod, Alaska pollack and Atka mackerel per one operation was on the average 1.7 times as much, while the catch of bottom fish such as halibuts, flounder, and "Kajika" was 1.4 times as much as usual.

Comparing the "25-Nen" Style net with the "27-Nen" Style net, the latter is of thinner net twine and smaller in shape, as already mentioned so that its handling is easy. Moreover, the tension imposed on the towing rope during net towing and hauling is smaller by about 400 kg on the average, and in addition, the catch was larger by 20%, according to the results of comparative experiments at the same fishing ground. The speed of ship 15 minutes after the start of net towing was 1.4 nautical miles for the "25-Nen" Style net, and 1.6 nautical miles for the "27-Nen" Style net.

The reason why the difference of speed was so little may be attributable to the fact that the ship was towing a long heavy towing warp together with the net and therefore a marked effect of the nets themselves on the speed of ship did not manifest itself.

The improved manila twine net is more bulky as compared with the cotton twine

net, so it is rather unwieldy on the deck of the fishing boat. However, the manila twine net answers our purpose in the waters off Hokkaido and in Northern waters or Hokuyō, where we find fishing grounds favoured with very dense shoals of fish and a large amount of catch per one operation. Usually the operation can be repeated frequently. The improved net was designed to have a much larger mouth than the usual cotton twine net so as to increase the catch of fish living near the sea-bottom.

The reason why wire rope was used for the lacing line is that it does not stretch as does the vegetable fiber rope even after use for a long while and so it induces no change in the "Hopping" of the net, and moreover, it is effectual for the reinforcement of the fishing net.

The iron pendant swivel which was used instead of the wooden pole or "Tegi", as already mentioned, accelerates the sinking of the net; it untwists completely the twist of the net generated during towing, and moreover produces a muddy screen at the sea-bottom.

Some people have considered that the longer the "Tegi" is made, the wider the ends of the large mesh wing net extend.

However, in the present writer's opinion, the large mesh wings and the ordinary wings of the net are not necessarily to be considered to be completely spread during the towing of net, even if the "Tegi" is employed, judging from the fact that the bottom mud, bottom creatures and deposits are attached to the lower wings when the net is hauled in. So it is considered to be profitable to use the iron pendant swivel instead of "Tegi".

The ground rope which was employed for the improved net seems to strengthen the whole net and to render it more effective for catching the fish living close to the sea-bottom than the usual porcelain sinker.

Opening end of the cod end for taking out the catch in the improved net is much more convenient and of higher efficiency than the usual method of scooping up the catch with a dip-net from the mouth of the body net.

## 2. The strength of glass ball floats used in deep-sea fishing

Among the netting fisheries, the one-boat medium trawl fishery is that which is operated in the deepest layer of the sea. Hence arises frequently a question as to the strength of the glass ball floats which are employed as buoys of the net. On the strength of glass ball floats, Kobayashi, Takahashi and Ueno (1951, 1954) have published their basic studies. With their results the present author compared his own observations on the breakage rate of glass ball floats 12 cm diameter which are used for the trawl net in Hokkaido district in deep sea fishing grounds, and came to a conclusion as follows:

According to Kobayashi *et al.*, the weight of a thick-walled glass ball float having a diameter of about 12 cm is 430 g and its buoyancy is 443 g, while the weight of a thin-walled similar float is 371 g and its buoyancy is 501 g.



The resistant power of the float against pressure in the water will be calculated from the following equation, on the assumption that the glass ball is an ideal sphere.

$$P = 2t \sigma / r$$

Here,  $\sigma$ : breaking compressive stress ..... kg/cm<sup>2</sup>  
 $P$ : breaking pressure ..... kg/cm<sup>2</sup>  
 $r$ : outside radius of the glass ball float ..... cm,  
 $t$ : wall thickness of the glass ball float ..... cm,

As there is no practical glass ball float with the wall less than 1 mm in thickness, a calculation from the above equation shows that the pressure resisting power of 1 mm thick walled float corresponds to 3000~4000 meters depth and that of 2 mm thick walled float corresponds to 6000~8000 meters depth. However, the author's experiment carried out at a depth of 820 meters off Shakotan Peninsula, Hokkaido, on the scale of a practical fishing resulted in a finding that 4 balls out of 50 glass ball floats having diameter of 12 cm were broken or filled with sea water. Two successive experiments with the remaining 46 glass ball floats at a depth of 805~842 meters resulted in the break of only one float at an early stage of these experiments. Thereafter, no breakage of floats occurred. Then, the breakage rate at a depth of 805~842 meters was 8%. The reason why the glass ball floats which are theoretically able to resist the pressure corresponding to the sea depth of 3000~8000 meters showed the breakage rate of 8% at a depth of 842 meters may be explained as follows; (1) the glass ball is not an ideal sphere, (2) the thickness of the glass ball wall lacks uniformity, (3) air bubbles exist in the glass, (4) residual stress. These points suggest that the actual resisting power of the floats against pressure is lower than its theoretical value.

Kobayashi *et al.* (1954) have ascertained from their experimental results that the breaking point of the floats is nearly always restricted to the plug of the glass or its surrounding areas. They presumed the rate of the inferior goods among the glass floats having a diameter of 12 cm manufactured in the glass factory at Hakodate to be 3.9~14.7% with 98% confidence rate. This is in agreement with the breaking rate observed by the author in his experiment.

The limit of the depth to be exploited in these days by the trawl fishing is 800~900 meters even in the case aiming at some sharks or arrow-toothed halibut which live in the deeper sea. Therefore, the loss of glass ball floats due to the breakage by water pressure may be considered within the above mentioned limits even in deep sea fishing.

Note: The plug of the glass ball is a glass stopper for the hole left after the blow-pipe is removed.

#### IV. STUDIES ON THE METHODS OF THE TRAWL FISHERY

##### 1. Relation between the amount of catch and the different ways of casting net

(1) The purpose of one-boat medium trawl fishing is to catch fish by lowering a long towing warp and a fishing net connected to it to the sea-bottom, and enveloping the fish living near the bottom. It is contrived to make a catch by scooping up fish in the area surrounded by the towing warp. However, the ratio between the catch and the amount of fish present in the surrounded area has not been clarified. According to the manner of casting the warp, that is to say, the method of casting the net, the amount of catch seems to vary, but the comparative merits of various methods have never been studied.

The author carried out in 1952 and 1953, a comparative experimental fishing by two different methods of net casting, and could find a tendency of one method of net casting to show a superiority over the other as shown by the amount of catch.

(2) Employed ship and fishing gear

a) The training ship "Hokusei-maru" (104 gross tons, 210, H.P.) of the Faculty of Fisheries, Hokkaido University.

b) Towing warp was manila rope, 28~32 mm in diameter, 2000 meters in one side length, 4000 meters in length in total of both sides.

c) Fishing net was made of manila twine weighing 3~6 g per 165 cm. The head rope was 53 meters long. The finished total length of the net was 37 meters (cf. Fig. 23).

(3) An experiment of this kind to be carried out in an actual fishing ground cannot avoid roughness as compared with a laboratory work, so the author paid, in this experiment, special attention to the following points.

a) To locate the experimental fishing ground, the author chose places at the same position as far as possible and where a large amount of catch could be expected.

b) The fishing ground was located in water areas which are almost similar to each other in the depth of water and the bottom material.

c) Comparison of the amounts of the catch was made among the fishing experiments operated at short intervals.

d) The time required until the towing warps first become parallel, and the number of revolutions of the main engine and the warping drum were kept uniform. The method of casting warps and nets was the same as in a usual fishing boat.

(4) Granting that each end of both towing warps in free from the fishing boat and the towing warps are 2000 m in length at one side (the total length including both sides is 4000 m), dimensions of the areas enclosed by the warps are in the following ratios according to the shape of the enclosed areas. Grant that the area in the shape of regular round is 1, the area in the shape of regular pentagon is 0.87, the area in the shape of regular triangle 0.60, and the area in the shape of isosceles triangle (when one-side is 1600 meters long) 0.44. Thus the area enclosed by the warps in the shape of regular round is largest, while that enclosed by the warps in the shape of an isosceles triangle is smallest. When the enclosed area takes the shape of an isosceles triangle,

the shorter the side, the larger the area (in case the bottom angle is  $>90^\circ$  > bottom angle  $>60^\circ$ ).

If it is the extent of the area enclosed by warps that determines the amount of the fishing catch, the most effective mode of casting warp should be that taking the shape of a regular round or a regular pentagon. However, to cast the warp in the shape of right circle is difficult for the current navigating technique, and to cast it in the shape of a regular pentagon is rather troublesome from the technical point of view because it necessitates the fishing boat to change her course four times.

Accordingly, the author made a comparison between two practicable modes of casting warp, namely casting in the shape of isosceles triangle (one side being 1600 meters long) and in the shape of regular triangle for amount of catch, with the intention of learning whether we can really say that the larger the enclosed area, the greater the amount of catch, in other words, whether a mode of casting warp to enclose a larger area is more effective in catching fish when the warps of the same length are employed (cf. Fig. 25, *a*, *b*).

Explanation of Fig. 25 will be given here as follows :

Fig. 25 *a* shows the mode of towing the warp in the shape of an isosceles triangle. "B" is the float, "S" is the fishing boat, and the arrow denotes the head way of the fishing boat when the net is being cast. When the towing warp of the same length is used, the area enclosed by the warp cast in this shape will be 0.44 granting that the area enclosed by the warp in the shape of regular round is 1.

Fig. 25 *b* shows the mode of towing the warp in the shape of a regular triangle. Grant that the area enclosed by the warp in the shape of a right circle is 1, the area enclosed by the warp towed in this shape will be 0.60, which is larger than the area shown in *a*. However, the length of the base (c) of the isosceles triangle is shorter than that ( $c_1$ ) of the regular triangle, so the time to be elapsed after the tow of net is begun until the advance of the net itself starts will be shorter in the former mode of net casting than in the latter.

(5) In the trawl fishing ground in the sea northwest of Hokkaido, the

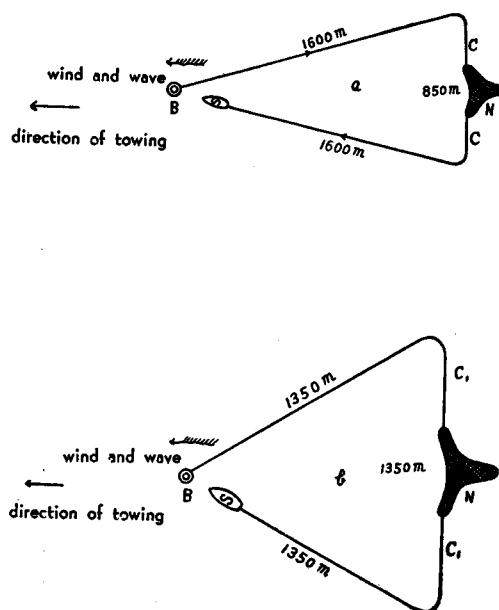

Fig. 25. A model picture of setting the one-boat medium trawl net

a ....Setting net style as an isosceles triangle  
b ....Setting net style as a regular triangle

author carried out comparative experiments 27 times in the summer of 1952 (casting the net in the mode of isosceles triangle 14 times, in the mode of regular triangle 13 times), 11 times in the summer of 1953 (in the mode of isosceles triangle 8 times, in the mode of regular triangle 3 times), in all 38 times. These experiments were classified into 3 groups, A, B, C, by the resemblance of the experimental location and date. The total catch of all repeated hauls by each mode of net casting and the mean catch per one haul are shown in Tables 10 and 11.

Considering from Table 11, in the case of A, there is a significant difference in F-distribution  $F_0=1.84$ ,  $n_1=6$ ,  $n_2=6$ , level is 5%.

Table 10. Results of operations by two setting net style

No.	Date (Aug.'52)	Time		Position		Depth (m)	Setting net style (triangle)		Catch (Kan) (1 Kan = 3.75kg)
		Casting net	Hauling net	Lat. (N)	Long. (E)		Isosceles	Regular	
1	3	6:10	7:50	43-34.0	140-02.8	96	○		49.0
2	3	8:48	10:20	43-35.5	141-02.9	96		○	13.5
3	5	5:46	7:45	43-33.7	141-02.3	92		○	43.0
4	5	8:30	10:10	43-34.3	141-03.0	94	○		50.0
5	5	13:00	15:00	43-36.2	141-02.8	98	○		78.0
6	5	15:25	17:10	43-35.6	141-03.2	96		○	36.0
7	7	6:30	8:15	43-29.0	141-03.0	90	○		103.0
8	7	8:30	10:00	43-30.0	141-02.7	91		○	33.0
9	7	10:20	12:10	43-30.0	141-03.3	92	○		130.0
10	7	12:33	14:20	43-31.1	141-02.0	96		○	47.0
11	12	8:10	10:10	44-15.0	141-12.3	158		○	200.0
12	12	10:40	12:35	44-15.7	141-12.5	170	○		235.0
13	12	13:25	15:15	44-14.0	141-12.2	180		○	267.5
14	13	4:45	6:30	44-12.8	141-12.5	165	○		243.0
15	15	15:40	17:30	44-14.0	141-12.0	180		○	161.0
16	15	17:50	19:40	44-11.5	141-12.0	190	○		119.0
17	16	4:20	6:15	44-07.2	141-11.7	200		○	262.0
18	16	6:35	8:25	44-09.0	114-12.0	175	○		197.0
19	18	16:25	18:10	44-00.5	141-13.5	190		○	123.0
20	22	13:40	15:25	44-15.0	141-12.3	165		○	158.0
21	22	15:45	17:30	44-13.7	141-11.2	190	○		246.0
22	23	4:22	6:30	44-12.6	141-11.9	180	○		112.0
23	23	7:03	9:7	44-12.8	141-13.0	160	○		131.0
24	29	7:30	8:55	43-31.3	141-05.0	78		○	30.0
25	29	9:12	10:30	43-32.8	141-05.7	83	○		32.0
26	29	10:55	12:25	43-35.2	141-03.3	100		○	43.0
27	29	12:45	14:15	43-34.5	141-02.0	100	○		39.0
(Aug.'53)									
1	5	7:10	8:45	44-13.0	141-11.0	210	○		163.0
2	5	9:30	10:55	44-14.0	141-11.5	195	○		164.0
3	5	11:15	12:56	44-11.0	141-09.7	200		○	102.5
4	5	13:21	14:52	44-11.7	141-10.7	190	○		226.0
5	5	15:12	16:45	44-12.0	141-10.5	210		○	91.0
6	5	17:00	18:46	44-11.0	141-12.0	170	○		155.0
7	9	4:20	6:15	44-07.5	141-11.5	160	○		179.2
8	9	6:25	8:23	44-08.0	141-11.0	145	○		311.0
9	9	12:42	14:32	44-07.0	141-14.0	160	○		119.1
10	9	14:45	16:30	44-07.0	141-14.0	150		○	110.0
11	9	17:10	18:15	44-10.0	141-13.0	155	○		242.0

Table 11. Difference of the catch by two setting (casting)-net styles

Section	Date	Position	Isosceles triangle style				Regular triangle style			
			No. of operations	Catch	Average catch per 1 haul	Variance	No. of operations	Catch	Average catch per 1 haul	Variance
A	Aug.'52	Area near N/E, 20' off Takashima L.H. at Otaru	7	481.0	68.7	133.2	7	245.5	35.1	72.4
B	Aug.'52	Area near S 31°W, 10' off west end of Teuri Is.	7	1283.0	183.3	3715.2	6	1171.5	195.2	3473.6
C	Aug.'52	" "	8	1559.1	194.9	3746.5	3	303.5	101.2	86.5

Remark: unit of catch: Kan (1 Kan=3.75 kg)

From the results of significant test in F-distribution, the value of  $F_0$  is 1.84 in the case of A, and the significant level which is 5% in F-distribution of  $n_2=6$ ,  $n_1=6$  is smaller than the level of 4.28. So the hypothesis that the sample is from the population having the same variance is not rejected. So, considering from the statistics based on the amount of catch, the amounts of fish caught by two different modes of net casting are regarded as the samples obtained from the sampling units of the same variance.

Therefore, on the assumption that the comparison of the mean value by two modes of net casting is presumably possible, the significant difference by F-distribution will be discussed.  $F_0=38.45 > F_{n_1}^{n_2}(\alpha=0.05)=4.75$ , significant level is 5%. The hypothesis that the sample is the one extracted from the same population having the same mean value is rejected. When the case of B is also dealt with by the same method, the variance in this case is shown as the following:

$$F_0 = 1.10 < F_5^6(\alpha = 0.05) = 4.95$$

And the mean value obtained in that case will be:

$$F_0 = 0.127 < F_{n_1}^{n_2}(\alpha = 0.05) = 4.84$$

So, the hypothesis that the sample is the one extracted from the same population having the same mean value is supported.

In the case of C, the variance is shown as:

$$F_0 = 43.3 < F_2^7(\alpha = 0.01) = 99.34$$

and the comparison of the mean value will be:

$$F_0 = 6.53 > F_3^1(\alpha = 0.05) = 5.12, \text{ significant level is } 5\%.$$

Therefore the hypothesis that the sample is the one extracted from the same population having the same mean value is rejected.

To draw conclusions from these results may be problematical to some extent, but it can be assumed that to cast net in the mode of isosceles triangle is capable of catching more abundant fish than in the mode of regular triangle.

In short, in the one-boat medium trawl fishery, when the towing warp of the same length is employed, the result of a catch by casting warp in the mode of an isosceles triangle enclosing smaller area of the sea-bottom or fish shoal is better than that of casting in the shape of regular triangle.

As a reason for this, the next consideration may be conceivable. Since the towing warps extending on either side of the net which correspond to the base of a triangle are shorter in the isosceles triangle than in the regular triangle, the time needed in the experiments operated for bringing the warps in the parallel position was 10 minutes in the isosceles triangular mode of warp casting and 15 minutes in the regular triangular mode. Thus the time to be elapsed before the net begins to go ahead is much shorter in the former than in the latter. Consequently, the escaping rate of fish shoal in the enclosed area, is supposed to be smaller and the amount of catch more abundant in the former. This is confirmed by the fact that the fishing boats engaged in the fishing of Alaska pollack and Atka mackerel first accelerate the rotation of engine and make every effort to scoop fish shoal into the net.

(6) The above described experiments were carried out under conditions of actual operation at a fishing ground. Unless the accurate velocity and direction of tidal currents, the effects of the wind and waves upon the boat, the movement of fish shoal confined within narrow limits, and the ecological difference of fish shoal are taken into account, no accurate conclusion can be obtained. However, it may be possible to discern at least a tendency that the casting of net is profitable when it is done in the mode of an isosceles triangle with a short base, or in the mode of a diamond shape which resembles the isosceles triangle.

## 2. Ideal length of towing warp in relation to the depth of the sea-bottom

(1) In the one-boat medium trawl fishery in which a long towing warp and a fishing net attached to it are used to catch bottom fish, it is very important to determine the ideal length of the towing warp in relation to the depth of the sea. If a towing warp which is too long for the depth is used it is not only a waste of high-priced materials but also it requires an excessively long time for completing the haul of net and moreover there is danger of allowing escape of fish. If the towing rope is too short, there is a fear of decrease in the amount of catch owing to the narrowness as well as the irregular shape of the area to be enclosed by towing warp on the sea-bottom.

In the otter trawl fishery, in which the net is towed around on the sea-bottom by means of the towing warp made of wire rope and by installing heavy otter-boards in order to open the mouth of the net, the ideal length of the towing warp customarily employed is 3 times as long as the depth of water when operated at 200 meters depth

which is the lower limit of the depth exploitable by such trawling. As the operation comes to be done in shallower water, the rate of elongation of the warp increases. In a shallow sea around 10 meters deep, the suitable length of towing warp is known to be 6~7 times as long as the sea depth. On the other hand, there has been no such study made in respect to the one-boat medium trawl fishery.

Since 1950, the author has carried out a study on the ideal length of towing warp in the fishery under consideration and published a paper on the problem in 1953. The results of his study will be summarized and discussed here as an item of the materials for a synthetic consideration of the trawl fishing methods.

(2) On a southern fishing ground off Teuri Island which is situated in the sea north-west of Hokkaido, from 1950~1953, the author studies the relation between the length of the warp adjusted in accordance with the sea depth and the amount of catch in 44 operations in the daytime during summer by using the same type of fishing gears and with respect to only those operations done by casting the net is the same mode.

Table 12. Relationship between warp length and depth as effecting the amount of catch

Warp length Depth (m)	Average catch per same ratio	No. of operatins		
		1950	1952	1953
8 (Times)	46.2		2	2
9	87.1		1	2
10	142.5	1	1	3
11	182.6		4	2
12	174.3	1	3	4
13	207.8		2	7
14	217.1	2	1	2
15	200.2	2		
16	229.0	1		
17	286.0	1		

Table 12 shows the relationships among the sea depth, the length of towing warp and the amount of the catch, and Fig. 26 shows a graph drawn from the data in Table 12. Among a total 44 hauls of net, the number of hauls by means of a towing warp which was 8~14 times as long as the sea depth was comparatively large. But the number of hauls by means of a warp 15~17 times as long as the sea depth was small. So the discussion given here will deal with the former case only.

(3) When the towing warp was 8 times as long as the depth of the sea, the catch per one haul was minimum. The catch increased rapidly with the elongation until it reached 9~11. After it exceeded 11, the increase of the catch became slow. That is to say, towing warp should be at least 11 times as long as the sea depth, and when the rate of elongation was 13~15, the fishing efficiency was maximum. For example, in the fishing ground at a depth of 100 meters the one-side length of towing warp should be at least 1100 meters (5.5 coils) and its ideal length is 1400 meters (7 coils).

In the fishing ground at a depth of 200 meters the minimum one-side length of towing warp should be 2200 meters (11 coils) while its ideal length is 2800~3000 meters (14~15 coils).

(4) From the results obtained the ideal length of the towing warp in relation to the sea depth was ascertained. However, the density of the population of fish will vary from year to year, and even in the same year the catch will vary with the change of

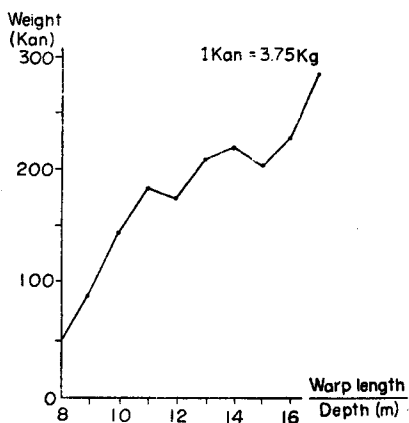

Fig. 26 Relation between the catch and the warp length per sea depth

the seasons to operate fishing, with the change of the amount of resources due to the difference of water depth, and with the change in reaction of fish shoal to the fishing gear due to the difference of the fish kind. Accordingly there is left room for study. In any case, the results obtained and above described are believed to be useful as one of standards of fishing for the practical operation of fishing boats (Fig. 26).

3. On the sinking velocity of the towing warp and net

(1) In the one-boat medium trawl fishery, after the towing warp and net have reached the sea-bottom, the fishing boat begins to go ahead hauling up the fishing gears and thus the bottom-fish are caught. So, it is very important to know the exact time required for the towing warp and net to reach the bottom. Fishermen used to consider by experience up to now that it took the towing warp and net about one minute per "10 Hiro" ("1 Hiro" is 1.5 meters) to sink to the bottom. However, no study has hitherto been done to test whether this sinking velocity is true or not, except a simple measurement of the sinking velocity of an experimental fishing net by an ultrasonic echo-sounder reported by Hashimoto (1951). The present author (1950~1952) carried out experiments in a fishing ground to measure the sinking velocity of the trawl fishing gears under actual operating conditions by using electric depth-meter, and also the sinking velocity of the towing warp only by using an echo-sounder. The results obtained have already been published (1953), but they will be summarized and discussed here again as follows since they are believed to be important for the operation of the trawl fishery.

(2) (a) Fishing net: Made of cotton yarn, "No. 20~30 Go" (3~3.5 mm in diameter); the head rope "190 Shaku" (about 58 meters) long; the total length of the fishing net "170 Shaku" (about 52 meters). This is such a net as is generally used by the one-boat medium trawler in Hokkaido and Aomori districts.

(b) Towing warp: three kinds of manila rope, namely, 6 coils of the rope "9



Bu'' (2.7 cm) in diam., 8 coils of the rope "9.5 Bu'' (2.9 cm) in diam., and 6 coils of the rope "1 sun'' (3.1 cm) in diam.. In other words, the rope attached on one side of the net was 2000 meters in length (10 coils in volume), so the total length of the rope used was 4000 meters (20 coils in volume).

(c) Instrument: Electric resistance depth-meter (cf. Reports of the Research Association of Deep Sea Fishing Ground in the Northern Japan Sea Nos. 2, (1951), 3, (1952)).

(d) Echo-sounder (Nippon Denki K.K. "Type-101") (cf. II-(2) of the present paper).

(3) The experiments were carried out at a depth of 86~105 meters in the sea area northwest of Hokkaido under the least effect of tidal currents and with a plane bottom consisting of fine sand. The training ship of Hokkaido University, "Hokusei-maru", and the above described fishing gears, were employed for this study. The observation of the sinking velocity of the towing warp only was made at 48 meters depth by means of the echo-sounder. The trawl fishing gears owe their weight mostly to the towing warp. The manila rope warps employed for the present experiments were those attached to a full-equipped used fishing gear under conditions of actual operation, and they were examined in the following three states of dryness or wetness.

(a) In the state of complete dryness.

(b) In the state of half dryness.

(c) In the state of wetness immediately after being hauled up from water.

Experiments were carried out by the usual net casting method of the one-boat medium trawler. An electric resistance depth-meter was attached to the point 6 meters from the end of the wing net, and its indicator was operated from an attendant small boat (Fig. 27).

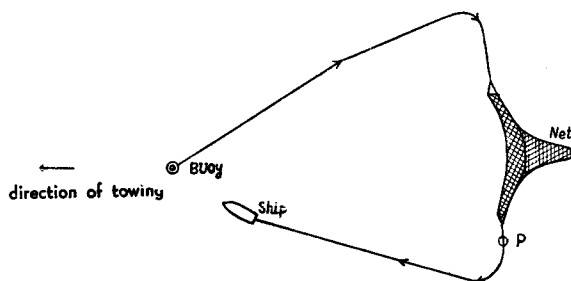

Fig. 27. A model diagram of the course line of a fishing boat when sinking velocity of the trawl fishing gears was observed

To make an experiment on the sinking velocity of the towing warp by an echo-sounder, a used manila rope "9 Bu'' (about 2.7 cm) in diameter was cut into 50 meters long pieces. They were hung down from the boat along her side and were carefully sunk just below the echo-sounder.

(4) The first experiment (1950) was a provisional one, with the fishing gears in the state of half dryness. According to the results obtained, the sinking velocity in the first water layer down to a depth of 20 meters was 10 m/min, in the second down to 60 meters depth it was 14 m/min, and before reaching to a depth of 93 meters (the bottom) it was 10 m/min. The mean velocity was 11.6 m/min (cf. Fig. 28, chain line).

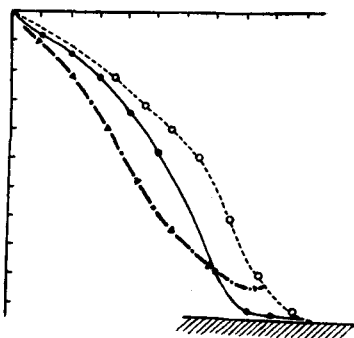

Fig. 28 Graph of comparative sinking velocities of the trawl fishing gears

The second experiment (1951) was carried out with the fishing gears in the state of complete dryness. In the first 6 minutes after the net was cast, that is to say, down to 45 meters depth, the gears sank rather slowly at a speed of 7.7 m/min. Thereafter the sinking velocity increased; at 50~90 meters depth to which the gears sank after 6.5~8.5 minutes, it was 20 m/min, and the maximum velocity was 23 m/min, at 70 meters depth to which the gears sank after 7.5 minutes. Thereafter the velocity gradually decreased, and it became as

slow as 4 m/min just before the fishing gears reached the bottom (cf. Fig. 28, dotted line).

The third experiment (1951) was carried out with the wet fishing gears, which had just been hauled up from the water, so they were fully drenched with sea water. One minute after the gears were cast, they sank to 8 meters depth, after three minutes at a speed of 10 m/min. After 6 minutes they sank to 65 meters depth, when the sinking velocity was maximum. Thereafter the velocity gradually decreased. At a depth of 47~90 meters to which the gears had sunk after 5~7 minutes, the sinking velocity was 20 m/min on the average being nearly the same as in the previous experiment. Just before reaching the sea-bottom, the velocity was slowed down to 4 m/min, as observed also in the previous experiment (cf. Fig. 28, solid line).

The fourth experiment (1952) was performed by using an echo-sounder to test the sinking velocity of the towing warp only. At first, the half-dried rope was proved to take 3.5 minutes to sink from the sea surface to the bottom at 48 meters depth; thus it sank at a velocity of 13.7 m/min on the average. Next, the rope completely soaked with sea water was tested. It took 3.1 minutes to reach the bottom at the same depth as the foregoing, its velocity being 15.6 m/min on the average. Fig. 29 is a photograph of the echo-sounder record taken in this experiment.

(5) The first and the third experiments were made under nearly the same conditions with wet fishing gears under operation. The results obtained differ a little from each other. Considering from the experimental operation and the curves obtained the third experiment seems to be more reliable. However, the mean sinking velocity

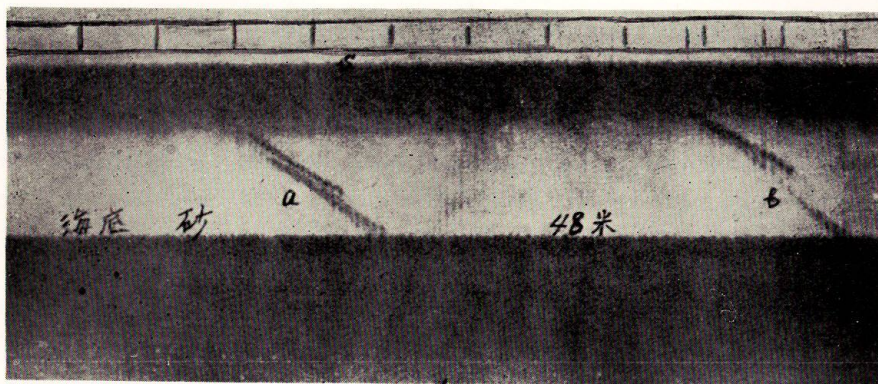

Fig. 29 Echo-image recorded by an echo-sounder of sinking of the towing warp

measured in either of the two experiments is nearly in accordance with each other, being 11.6 m/min and 11.3~11.6 m/min on the average in the first and third experiments respectively.

In the second experiment with the dried fishing gear, it was 10 m/min on the average. The slow sinking velocity just before the gears reach the sea-bottom is considered not free from some error due to a discrepancy in observers' reading of the time. If it is excluded from the consideration, the wet fishing gears are concluded to have sunken at a speed of 12.5 m/min, and the dried fishing gears at a speed of 10.6 m/min.

The sinking velocity of the fishing gears which has hitherto been considered by experience to be "10 Hiro" ("50 Shaku" = about 15.2 meters) per one minute must be corrected to "8.2 Hiro" ("41 Shaku" = about 12.4 meters), according to the results of the present experiments. Nevertheless the customary fishing operation based on the view that the gears sink at a speed of "10 Hiro"/min has resulted in no great difficulties except in the subabyssal fishing ground of the arrow-toothed halibut. This may be due to the fact that fishing gears reach to the sea-bottom by the time the towing warps on either side of the net becomes parallel to each other or the towing warp begins to be hauled up by winding.

In the experiment carried out only with the manila rope which is used as the towing warp the wet rope sank at a speed of 15.6 m/min, that is "10 Hiro"/min. Such a rapid velocity was only observed in the case of a comparatively short rope, which was naturally not only free from the effect of buoyancy of the floats attached to a warp as a part of a fully equipped fishing gear bearing a net, but also different from such a warp as in the first and third experiments which was sunken in the sea just as in an actual operation being supported at one end by the boat.

Those fully equipped fishing gears sank less rapidly as described above, a wet fishing gear at a speed of 12.5 m/min and a dried fishing gear at a speed of 10.6 m/min.

(6) The sinking velocity of a fishing gear depends complicatedly on various conditions such as properties, kinds and freshness of the fishing gear materials, structure of the gear, tidal currents, speed of the fishing boat at the time of net casting etc. So it is difficult to obtain an accurate result as can be done in a laboratory experiment.

The results obtained in this experiment may be applicable with satisfaction to the one-boat medium trawl fishery because they show a general tendency of the sinking velocity of fishing gears in an actual state of operation at a fishing ground.

In short, the sinking velocity "10 Hiro"/min or 15.2 m/min as has hitherto been claimed for the fishing gears by experience should be considered as the minimum, so it is necessary to wait at least a little longer than the time calculated from that velocity before starting the haul of the casted net.

4. On the state of a fishing gear under operation as observed by means of the submarine observation chamber "Kuroshio"

(1) In what manner the trawl net moves under operating in the sea has been only imagined until recently. Experiments by using a model of the trawl (drag) net were carried by Miyamoto (1936), Saruta (1952), Nomura and Yasui (1935) and Koike (1953). Inoue *et al.* (1953) made underwater observations on the movement in the sea of the two-boat large trawl fishing gear by the submarine observation chamber "Kuroshio"\* and the present author (1953) on the movement of the one-boat medium trawl fishing gear under operation by means of the same instrument as described below (cf. Fig. 30, a).

(2) Observations were made under the collaboration of the submarine observation chamber "Kuroshio" and the two training ships of the Faculty of Fisheries, Hokkaido University, "Oshoro-maru" (616 gross tons) and "Hokusei-maru" (104 gross tons). The "Hokusei-maru" engaged in the fishing in the same manner of operation as a professional fishing boat, while the "Oshoro-maru" played the role of a mothership, and operated the "Kuroshio". The present author got aboard the "Kuroshio" as the observed with two other persons as the operators. The observed place was situated outside the Ishikari Bay, Hokkaido, at a depth of 38~46 meters; its bottom material was sand.

The observations were directed especially to the following items:

(a) The state of towing warp (manila rope). (b) The behaviour of fish in response to the towing warp. (c) The change of the sea-bottom conditions induced

---

\* The submarine observation chamber "Kuroshio" was built in August, 1951, at the Tsurumi Ship-yard of the Nippon Kōkan Co. Ltd., according to the plans by N. Inoue (Hokkaido University), C. Sasaki (Scientific Research Institute), and R. Oaki (Kokusai Sempaku Co.) under the suggestion of Prof. U. Nakaya of Hokkaido University. It was designed with the object of studying deep sea from the view points of Fisheries and Oceanography. It can be lowered to the depth of 200 meters.

by passage of the fishing gears. (d) The state of the fishing net.

(3) The initial state of the towing warp before the boat begins her forward movement following the completion of the net casting was in the shape of a snake spreading loosely on the sea-bottom. After the boat started to advance, the warps ran in a state of high tension rubbing on the surface of the bottom until the two towing warps become parallel (The boat's speed was 1.6 knot).

At first, while the warps were moving in a high tension state before they become parallel, a large number of annelida-like creatureas were observed being spread all over the bottom with their tentacles opened like morning glory flowers in the direction believed to be that of the tidal current. After the warp passed cutting down those creatures, there remained no perfect one. Some bottom fish having nearly the same color as the sea-bottom were observed to leap up being frightened by the passing warp. Judging from the speed of the warp, those fish must have escaped capture by jumping outside the path of the warp.

The wing nets standing still before the hauling of net begins were up right with their meshes opened in the shape of a square. Four to five glass ball floats at about 1 meter intervals and the quarter rope running along the head rope were also clearly

Fig. 30. a.

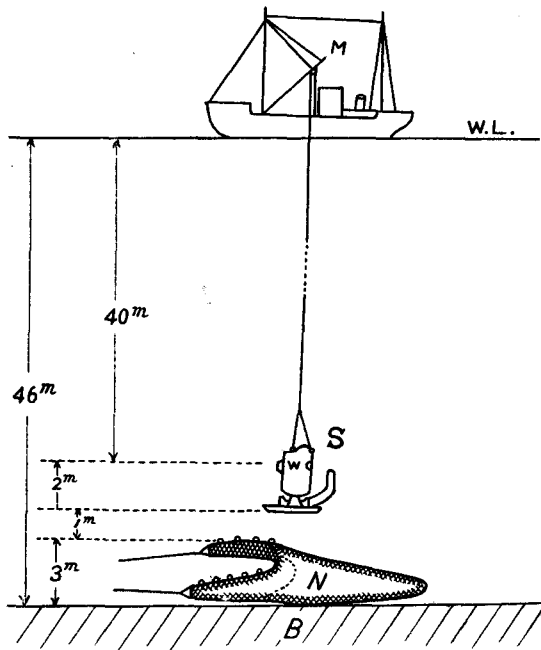

Fig. 30. b.

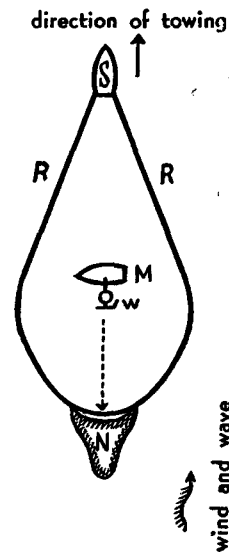

Fig. 30 a, b. Relative positions between a submarine observation chamber(W), a mother-ship (M) and fishing gears(N)

observed. The visibility of those portions of the gear may of course have depended upon the water transparency.

While the towing warp was being hauled with the advance of the ship and the net was moving forward, the state of the body net was observed through the window of the "Kuroshio" by moving it also in the same direction. As result, the net was revealed to advance with the mouth opened vertically as high as about 3 meters as calculated from the height of the window of "Kuroshio", from the base of the setting stand, the distance between the setting stand and the net, and the depth of water from the sea surface to the center of the window (cf. Fig. 30, b).

It was also observed that the boundary between the wing net and the body net was sufficiently swollen, and the meshes were also fully opened. The black color of the manila twine net dyed with coal-tar was also recognizable.

The behaviour of fish shoal in relation to the fishing net could not be observed because of the invisibility of the shoal. The layer of turbid water due to the cloud of mud and sand generated after the passing of the towing warp was about 0.5 meters in vertical thickness, while the sea water became very cloudy after the passing of the fishing net and the height of the turbid layer reached as much as 5 meters.

(4) The results obtained by the underwater observations may be summarized and discussed as follows :

1) When the bottom fish such as halibuts, flounders, "Kajika", etc. are the object of fishing, the towing speed of fishing boat until the two towing warps become parallel need not be more than 1.5 knots, and it will be profitable to increase the number of engine revolutions in order to gain speed at the time when the two towing warps became parallel.

2) According to Saruta and his collaborators' (1952) experiments with models on the opening of the trawl net mouth during operation, the opening was 1.0 m high for the otter trawl net, 2.0 m for the two-boat large trawl and 1.6~1.8 m for the one-boat medium trawl, while Nomura and Yasui (1953) reported that it was 1~1.5 m, 1.7~2.5 m, and 2.5 m respectively. According to the results of the underwater observations by Inoue *et al.* (1953), the opening near the mouth of the two-boat large trawl net was about 2 m high. On the contrary, the author's underwater observation on the one-boat medium trawl revealed that the opening of the net mouth was about 3 m in height when the boat was making a speed of 1.5~1.6 knot.

His result was nearly in accordance with the data reported by Nomura and Yasui in view of the structure of the net (cf. Fig. 23).

3) On the sea-bottom consisting of fine sand, the layer of turbid water was 0.5 m in vertical thickness after the passing of the towing warp, while it increased in thickness to as much as about 5 m after the passing of the fishing net.

4) The effect of the trawl fishing gears upon the bottom creatures appears to be remarkably severe as was noted with annelida in the present research.

5. On relative superiority of the port and the starboard side of the fishing boat in relation to the operation of the trawl net

(1) In Japan, the fishing gear is customarily operated on the port side of fishing boats, regardless of their fishing method, whether angling or netting.

The reason why the fishing gear is operated on the port side of the boat is not clear. In former days in Japan when all of the ships were of Japanese style, the main oar that steers the boat was set on the portside of the stern, and the fishing was also done for convenience' sake from the portside. Hence, a custom to operate the fishing gears on the port side seems to have remained even in modern times when the ship is steered with propeller and rudder.

Among the towing net bottom fishings, the otter trawl fishing of Europe has been operated in most cases in severely cold sea area, so the gallows were equipped on both sides of the boat, taking into account the possibility of their damage, and either of them was employed as occasion required. At the time when the trawl fishing was introduced into Japan, the two gallows system was also imported. However, since about thirty years ago the gallows on the port side was abolished and the net casting has come to be done only on the starboard.

In the case of the one-boat medium trawler, which hauls both of the towing warps through rollers on the stern, the operation is subject to the wind, wave and sea current. When the two wings are brought near to the stern the net is taken on board only at the port side.

(2) At present, most of the fishing boats are steered by engine and rudder. So it must be decided on which side of the fishing boat the fishing should be operated, from the viewpoint of the nature of the fishery to be done and taking into consideration the actions of the screw-propeller and rudder. It is wrong to persist in operation on the portside from habit. It is clearly reasonable to operate on the starboard from the theory of seamanship. The author (1949) has pointed out that it would be advantageous to operate the fishing gears of the otter trawler from the starboard in view of the workings of propeller and rudder, and the nautical manner ordained by the International Regulations for Preventing Collisions at Sea (1948). In the case of the one-boat medium trawler too, the right handed single screw-propeller is mostly employed, so it is considered reasonable to operate the gears on the starboard where the workings of propeller and rudder can be utilized. The author carried out trawl fishing experiments for six years on the training ship "Hokusei-maru" and also made observations on board the commercial one-boat medium trawlers on their operations. As a result, it was ascertained that the operation could be done more advantageously on the starboard than on the portside.

(3) (a) In the case of an operation to haul up the net on the portside, the relation between the ship and net is such as shown in Fig. 31, *a*~*f*. When the wide and

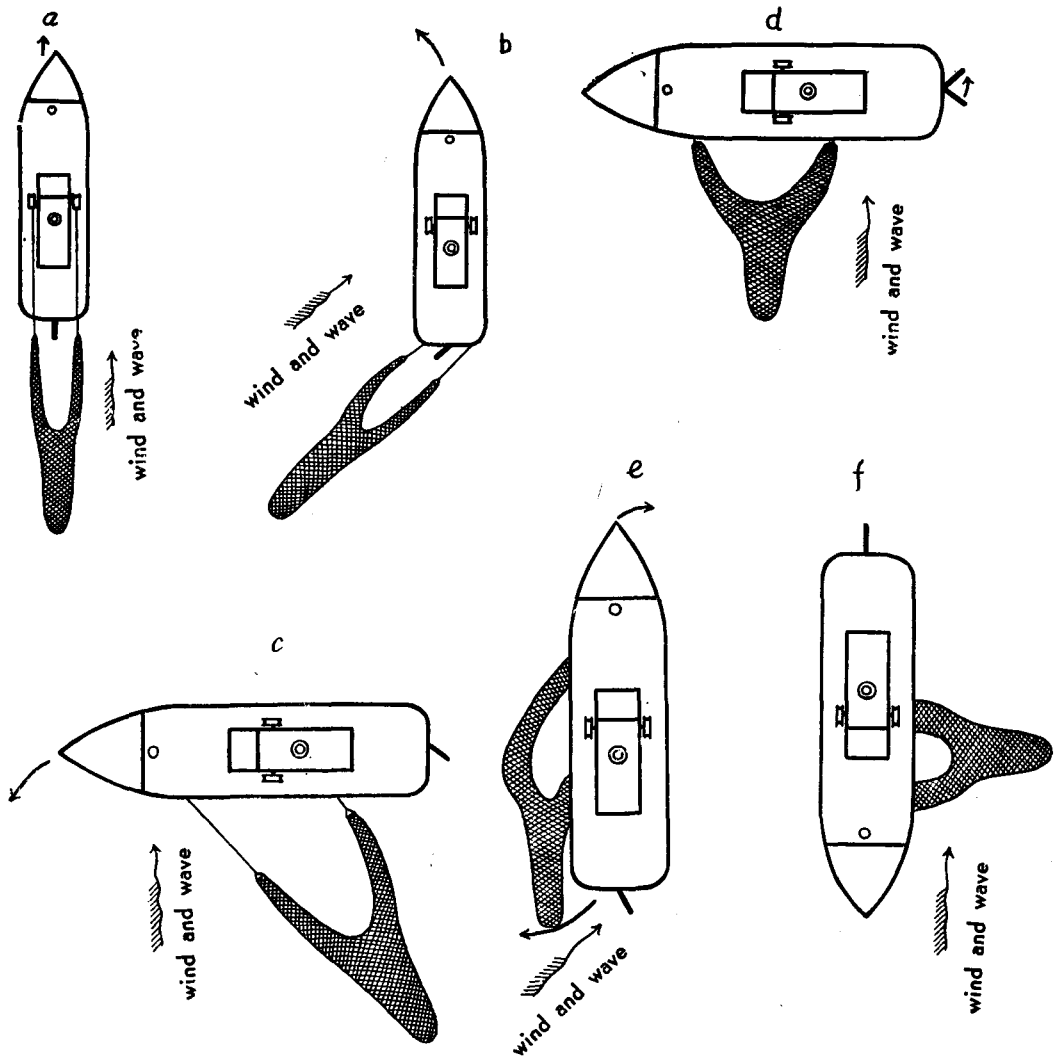

Fig. 31. (a-f) Showing operation of the net on the portside and movement of the fishing boat

sea go down to some extent and the velocity of the wind becomes less than Beaufort Wind scale 3, the operation will be easy even if the net is hauled onto the boat having the wind abeam. The net is taken onto the boat after the relative position of boat and net become as shown in Fig. 31, b and c is changed to the position as shown in Fig. 31 d, by setting the engine in backward motion. In this case, as a result of the backward motion of the engine, the stern of the boat turns to the left and her head turns to the right by the action of the propeller according to the theory to be mentioned



later. Consequently the hind wing-net gets near the propeller and there arises a fear that the net should get entangled with the propeller (Fig. 31, *e*). Although most of the one-boat medium trawlers, about 50 gross tons in size, are of a light construction easy to steer, the steering of the boat to put her in the position as shown in Fig. 31 *d* is by no means easy for almost no effect of the propeller can be expected but reliance must be placed only upon the action of the rudder itself which is induced by the discharge current.

When the wind and sea rise and the velocity of the wind becomes more than Beaufort Wind scale 4, the operation will be easy if the net is hauled onto the boat from abeam on the portside, keeping the head of the boat braced to the wind and the wave (Fig. 31, *f*). To keep the boat in this position, that is to say, to keep the net abeam of the port, the boat must be steered by setting the engine in forward or backward motion. In this case, the stern turns also to the left and so there arises a fear that the net should be drawn near the propeller.

In any case, the operation of the net on the portside is not only unsafe from the viewpoint of the steering of the boat but also makes the steering difficult.

(b) In the case of hauling the net on the starboard side of the boat, the relative position of the ship and net as shown in Fig. 32 *b*, can be easily changed to the position as shown in Fig. 32 *c*, by setting the engine in backward motion.

When the wind and sea rise, if the engine is set in backward motion while it is handled in various ways in order to keep the boat's head constantly faced to the wind and to haul the net on board on the starboard side from abeam, the stern of the boat turns to the direction indicated by an arrow in Fig 32 *d*, and consequently the screw-propeller will get away from the net, and thus the entanglement of the net around the screw-propeller can be avoided.

The reason may be explained as follows. Among the three physical actions induced by the screw-propeller, *i.e.*, transverse thrust, wake current and screw current, the transverse thrust gives pressure to the stern so as to make it turn to the left as a result of the fact that when the propeller revolves to the left by the backward motion of the engine, the water pressure against the lower blade of the propeller which rotates in the deeper water is larger than that against the upper one which rotates near the water surface (Fig. 33).

Wake current in this case has no influence on the movement of the boat, while the effect of the screw current is large. Screw current consists of discharge current and suction current. The discharge current arises from the revolution of the propeller, and while the boat goes ahead it strikes the rudder on its lower part from the right hand and on its upper part from the left hand. If the upper and lower parts of the rudder are similar in shape to each other, the power of pressure imposed on the rudder from either the left on the right side is equal, so the head and the stern of the boat are not turned to either direction. In the usual type of rudder which is narrow at

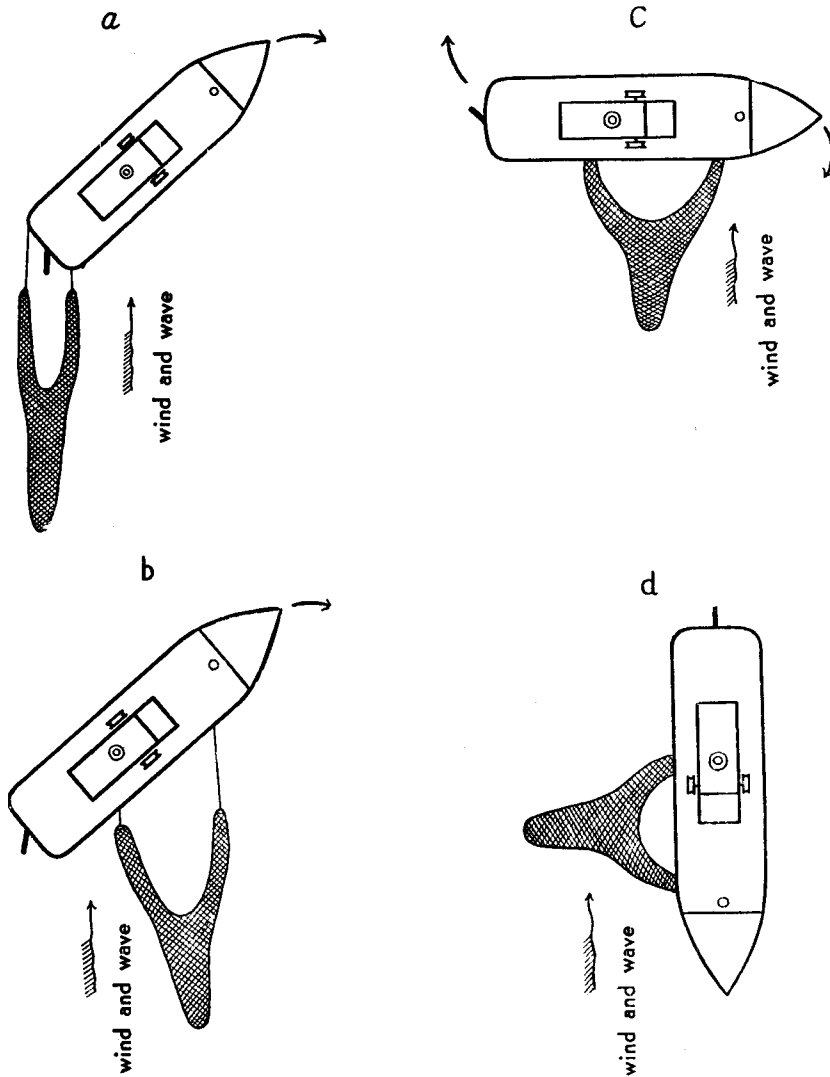

Fig. 32 (a-d) Showing operation of the net on the starboard side and movement of the fishing boat

the upper part and wide at the lower, the power of pressure imposed on its lower part is superior to that imposed on the upper part, and that causes the stern to turn to the left and the head to the right.

When the boat goes astern, the discharge current strikes both the upper parts of the hull at the stern on the starboard side and the lower part of the hull on the portside. In the latter case the larger part of the power of pressure escapes toward the under part of the keel, so the striking power imposed on the starboard stern is

superior to that on the other side. Consequently, the discharge current has a remarkable effect on turning the stern to the left and the head to the right, so the head of the boat does not turn to the left even if the rudder is steered to the starboard helm. This is because the effect of the discharge current is superior to the direct action of the rudder, induced by the suction current. That the stern turns to the left hand when the engine of the boat is set in backward motion, as described above, is due to the action of the discharge current and transverse thrust, of which the former is considered to be largest.

(4) It is a matter of course that the effect of the action of screw-propeller on the steerage of the boat varies according to the shape and size of the hull, especially of its stern and rudder, and it is also considered to be not necessarily definitely being exposed to the influence of various conditions of the wind and sea at any given time.

However, the tendency of most of the boats that install the right-handed single screw-propeller to turn the stern to the left hand when they go astern is clearly attributable mainly to be the action of the screw current.

So, in the one-boat medium trawler which must work in stormy weather at the height of the winter fishing season, it would be necessary to adopt the method to operate the fishing gears on the starboard side because this method is not only convenient to turn the boat in a small circle and to make the steerage easy, but also it is advantageous in preventing the net from becoming entangled around the propeller.

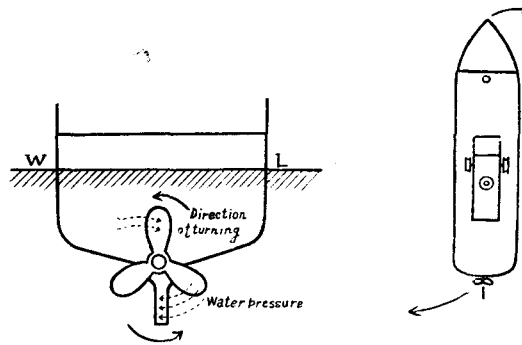

Fig. 33. Showing the action of the screw propeller when the ship is propelled and the movement of the fishing boat

#### 6. Ecological studies on the fish shoal by an echo-sounder and its applications to fishing (On the Alaska pollack shoal)

(1) The applications of the echo-sounder to the fishery have been studied in various ways. It has been applied not only to the detection of fish shoals, but also lately to studies of their ecology.

A.L. Tester reported that the vertical movement of the herring shoal was observed as early as 1943~44 by an echo-sounder and that the results were applied to fishing. In Japan, observations and ecological studies on fish shoals by an echo-sounder were reported by Kimura *et al.* (1952) for bonito and tuna shoal, by Owatari *et al.* (1953) for horse-mackerel and sardine shoals, by Yokota (1953) for sardine, horse-mackerel

shoals and other migratory fish shoals and by Takakura (1954) for Alaska pollack shoals in their spawning season. Besides these, studies have been carried on by the Fishing Boat Laboratory of the Fisheries Agency, and by the Fisheries Research Institute.

(2) The present author carried out ecological observations on Alaska pollack shoals by an echo-sounder\* which was installed on a research boat "No. 5 Tenyūmaru" belonging to the Association of Otaru One-boat medium Trawl Fishery, at the fishing ground off Yoichi, Hokkaido, during a period of about one month from near the end of December 1951 to the end of January 1952. A study on the application of the results of those observations to the trawl fishing and the long-line fishing ("Haenawa-fishing") has already been partly published (1954), but it will be discussed and described in detail in the following lines. At the above mentioned fishing ground a night-fishing was prohibited to avoid friction with the inshore fishermen engaged in the fishing of Alaska pollack by the bottom gill-net, so that no night record could be obtained. The state of things from early morning till twilight could be observed. (\*Cf. II-2, Fig. 1 *a-e* in this paper.)

(3) Takakura (1954) reported on the results of his ecological studies on the Alaska pollack shoal in spawning season by an echo-sounder at the fishing ground in Iwanai Bay of Hokkaido. According to his report, the shoal of Alaska pollack around the middle of November previous to the fishing season aggregates densely in the water layer 100 m deep irrespective of the undulations on the sea-bottom, in the shape of a band 80~100 meters wide and 30 meters thick. The shoal contains both male and female individuals. In the middle of December when the fishing season begins, the shoal appears in 100~160 meters depth in the form of 2 or 3 layers of cloud-like bands about 40 meters thick as a whole, of which the upper layer is occupied by the male and the lower layer by the female fish. In the middle of January at the height of fishing season, the shoal scatters widely at a depth of 80~160 m in the shape of snatches of cloud showing no change in shape night and day. The more the lower layer is occupied by the female fish the more the upper layer is occupied by male fish and by young fish which have nothing to do with the spawning. In the middle of February at the end of fishing season, the shoal is spread at 80~100 m depth in the shape of a two-layered band, of which the upper layer is reported to be occupied mainly by the almost matured male and the lower layer by the perfectly matured female fish as the principal constituent.

The author's observation on the shoal of Alaska pollack in Ishikari Bay, Hokkaido, was done from December to January at the height of its fishing season; it was revealed that the shoal had a tendency to gather at a place where the sea-bottom was suddenly shallow. Except at the height of the fishing season, the shoal did not sink down near the bottom, but gathered in the shape of a horizontal band, about 20~50 meters

thick, at a certain depth. Owing to the fact that the shoal thus spread horizontally, the shoal comes near the sea-bottom at a slope of the bottom, and so it can be caught by a trawl fishing net; but it gets away from the bottom at a place distant from the slope and as a result the catch by the trawl net decreases in amount remarkably (Fig. 34).

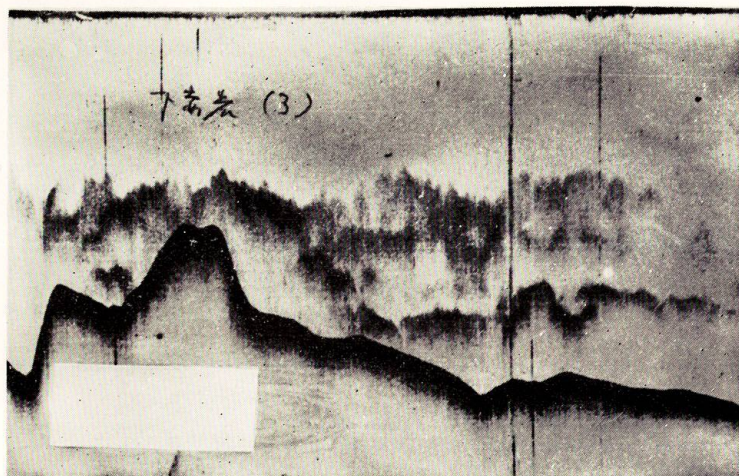

Fig. 34. Echo-image of Alaska pollack shoal of which the end approached to the bottom slope

Through the fishing season, the shoal which was recorded each day for the first time by the echo-sounder was present at 150 meters depth. Usually from about noon on, the shoal gradually began to sink and the hour at which the shoal reached near the bottom is the time when the most abundant catch of the day was obtained. At the height of fishing season, the shoal which had been in the shape of a band divided into two or three layers within one or a few days, the distance between each layer being about 50 meters. It gradually sank and got near to the bottom, and at the same time its lower layer became scattered in the shape of a stratus (Fig. 35). If the net was cast at such a time, the catch was very abundant. Such a condition was observed mainly at 1.00~2.00 p. m. of the day, varying with a cycle of three or four days. After an abundant catch was obtained as a result of the sinking of the shoal, a band-shaped shoal appeared again at 120~150 meters depth. It could not be determined whether this was a shoal which had once reached the bottom, or a newly arrived shoal. This shoal repeated the above described phenomenon. From this arises a circumstance that on the day following an abundant catch there would be nothing to catch.

The author once observed in a sea area 230m deep that a fish shoal, which had been detected around a quarter to 11 o'clock in the morning on Jan. 8, 1952, at a depth of 115 m, had sunk to a depth of 150 meters at noon. The fish shoal observed at this

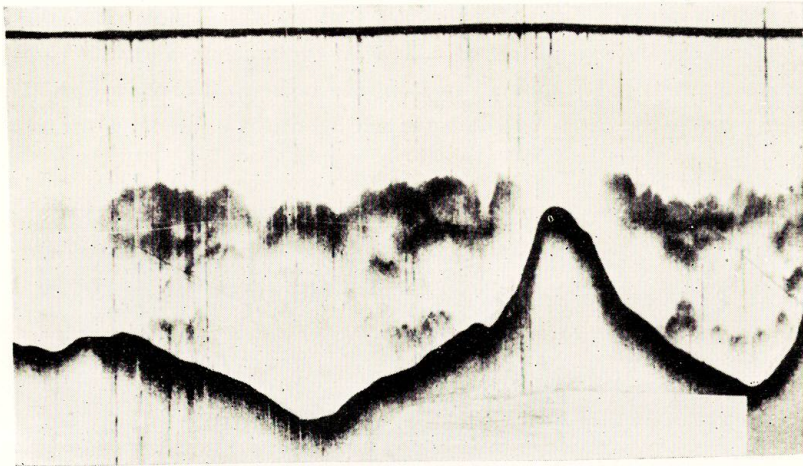

Fig. 35 Echo-image of Alaska pollack shoal which had sunk and scattered near the bottom

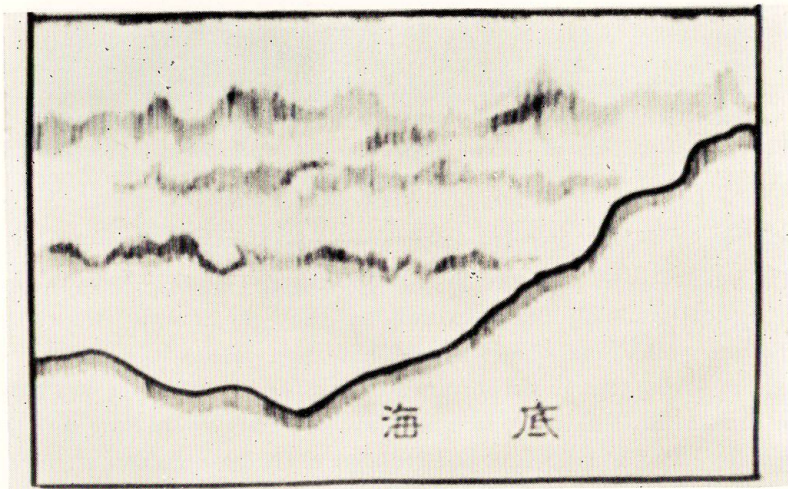

Fig. 36. Record of the echo-image of Alaska pollack shoals caught by an echo-sounder at the Alaska pollack ground in Ishikari Bay, Hokkaido

time in the forenoon consisted of large fish while the fish caught by net in the late afternoon of the same day were small in size. A fish shoal usually sinks down near the sea-bottom around 2 o'clock in the afternoon as already mentioned, but after the fishing season advanced and its final period approached, the catch begins to show increase even in an operation done in the late afternoon. This may be due to the fact that the fish shoal at this period tends to spread upward and downward so as to be scattered widely. Fig. 36 is a copy of the record of a fish shoal caught by the echo-sounder at the Alaska pollack ground in Ishikari Bay, Hokkaido. As learned from

the figure, the fish shoal at first gathered in from a layer at 150 meters depth, and then divided into two layers, of which the lower one was observed to sink gradually to the bottom.

(4) Judging from the state of the fish shoal as revealed by the echo-sounder and the catching result by the trawl fishing, the shoal of Alaska pollack that comes to the fishing ground so-called "Yoichi Taraba" in Ishikari Bay is found to stay in middle layer of the sea in the morning from 8 to 10 o'clock, but sinks gradually to the bottom about at noon, reaches to the bottom about 2 o'clock in the afternoon, and stays there till 5 to 7 o'clock in the afternoon. From this follows the fact that the catch by trawl in the afternoon is good. And there occurs a circumstance that a fishing attempted immediately after an abundant fishing results in no catch of fish. However, such is not the case with the long-line fishing which can alter its operating water depth at any time as occasion demands.

According to the angling results of the long-line fishermen, when there were two groups upper and lower, of a fish shoal, the upper one consisted mostly of small-bodied males whose rate of catch was high, whereas the lower one consisted mostly of large-bodied females whose rate of catch was rather low. These facts were also recognized by Takakura (1954) in Iwanai Bay at the height of fishing season from December to February. The fish shoal at first in a band-shaped group divides into two to three layers, and after reaching the bottom the band-shaped groups collapse and scatter. One to a few days later a shoal in the shape of a band appears again the middle layer of the sea. Those changes of states are repeated for some time. They are supposed to have a close connection with the propagation, but this problem is left to future studies to be solved.

In both the long-line fishing and the trawl fishing, fishermen can make good use of the above-described behaviours of fish shoals. When the shoal forms two layers and an abundant catch is aimed at, the fishing hooks lowered to the depth of the upper layer will catch male fish abundantly. If the catch of hard roe is aimed at, the depth of lowered fishing hooks has to be adjusted to that of the lower layer of the shoal. In the case of trawl fishing too, a rational fishery enterprise can be conducted by applying to the fishing the data of the ecological studies of the fish shoals gained by an echo-sounder, for example, by concentrating the labour upon the fishing in the afternoon or by suspending the fishing on the day following an abundant catch.

## V. GENERAL CONCLUSION

The present studies have been carried out mainly on the occasion of the "Investigation of Deep Sea Fishing Ground in Northern Japan Sea" and the "Investigation of Aquatic Resources in Aomori Prefecture". This article presents a synthetic study on the fishing ground, fishing gears, fishing technique of the one-boat medium trawl

fishing or the Japanese type trawl fishing; and the conclusions obtained can be stated as follows.

1. Application of the echo-sounder to the one-boat medium trawl fishing

The echo-sounder has been used on fishing boats as on general merchant ships for safety of navigation. However, since the end of the last war it has become to be used for the purpose of fishing, directly or indirectly.

(1) There are many kinds of fish which have a habit to gather about a sunken rock. Therefore, to find such a sunken rock frequently results in a chance to encounter a fish shoal. For instance, in the case of the bonito shoal which gathers around a sunken rock, fishermen at first locate the sunken rock in the ocean by using jointly an echo-sounder together with celo-navigation, then they attempt to gather the fish by scattering bait, and catch them by angling.

The author (1948) detected a sunken ledge having its shallowest part at a depth of 207 m between Ōshima Island and Kojima Island in the sea southwest of Hokkaido by means of an echo-sounder, and could learn its approximate area and shape. Thereafter an angling test for Alaska pollack was carried out, and it was learned that the amount of catch was larger in the neighbourhood of the ledge than in other water areas.

(2) To operate fishing at a fishing ground, it is necessary to take into consideration the state of natural feed-supply as well as the prevailing water temperature. The planktonic organisms good for natural feed-supply and the fish themselves are apt to gather around the current-rip under the effect of the current and water temperature, so it is needful to know the presence of current-rips and the plankton both as to kind and quantity for the purpose of deciding a spot to cast a net. The current-rip can be recognized by the naked eye in the day time but it is difficult to find it in the night. The author has been engaged since 1954 in a study on the possibility of detection of the current-rip from a horizontal direction by means of an echo-sounder designed as a fish-finder 50 KC equipped with an apparatus to support it in a horizontal position.

H.B. Moore (1950) published a report on the relation between the Deep Scattering Layer (D.S.L.) which appeared on the echo-sounder and the presence of *Euphausiaces*. The present author also could catch in November 1952 off Cape Esan, Hokkaido an echo image which seemed to have reflected from *Euphausia pacifica* on their way to rise to the sea surface at about sunset.

In the fishing aiming at migratory fish such as salmon, saury, mackerel, sardine etc., the present author believes that a time will come when the presence of zooplankton detected by an echo-sounder will be used as the basis on which the selection of the place to operate the fishing is decided.

(3) It is also conceivable to apply to the fishing the knowledge on the habit of fish obtained as a result of the ecological study of a fish shoal carried out by means



of an echo-sounder as a fish-finder. The author (1952) by means of an echo-sounder observed a shoal of saury gathered under the fish-alluring lights in the Tsugaru Straits between Aomori Prefecture and Hokkaido. Thus he could ascertain the correctness of the view holding that a shoal of saury which had been kept gathering under the alluring lights for a long time sunk down by habit gradually to deeper layer swimming in a circle keeping its center under the lights. He also observed the behaviour of a shoal of Alsaka pollack and succeeded to operate a rational fishing.

(4) The extent of utility of echo-sounder for the trawl fishery is very large. The results of the author's studies with respect to this subject are summarized as follows :

(a) It is necessary to know accurately the depth of the sea-bottom not only for determining the length of the towing warps in accordance with the water depth or for judging the kinds of fish inhabiting in that depth, but also for maintaining the fishing efficiency during the operation. For example, if a water depth promising abundant catches of fish is discovered, the fishing boat can be kept at the spot, not losing her position, by the aid of an echo-sounder even in the dark of night. By this method of operation, the author (1951) succeeded to obtain the maximum and constant catch among more than twenty fishing boat at the same fishing ground, during an experimental fishing of Atka mackerel operated on board the investigation boat "No. 5 Tenyū-maru".

(b) The sea-bottom gives a particular echo-image according to its material whether it is rock, sand or mud. To have knowledge on the kind of the bottom materials is quite helpful for anticipating the possibility of trawl fishing at a given place and the kind of fish inhabiting there. The author could operate a number of profitable fishings since 1949 by determining the nature of bottom materials from the echo-images.

(c) For the trawl fishery it is also very important to know the shape of the sea-bottom. From the shape is determined the possibility of the trawling as well as its course; also the presence of fish shoal is anticipated. The author (1948) examined the depth, bottom materials and the shape of the sea-bottom by means of an echo-sounder (14.5 KC) in the course of the "Investigation of Sea-bottom of Aomori Prefecture" and made a success of determining the value of a water area as the trawl fishing ground. That was the first attempt to apply the echo-sounder to the trawl fishing in Japan. According to the results obtained by the author a search for a new fishing ground or an operation in an unfamiliar water area can be carried on successfully by the following method. Namely, taking into consideration the extent of the area to be enclosed by the towing warps and fishing net in a prospective fishing ground, and the distance to be covered by the movement of the fishing gears, the fishing net is cast after the water area in question is examined in detail by an echo-sounder and the nature of bottom materials, declination angle of the bottom slope and the presence or absence of sharp rocks and ledges are ascertained. In this way, it is possible to

perform economic and safe operations which mean minimum loss of fishing gears and much saving of labor.

(d) In respect to the relation between the angle of the sea-bottom slope and the possibility of trawling, the author (1950) carried out an experiment to haul up a net after casting it on the slope,  $12^{\circ}32'.7$  in angle of inclination. As a result, the operation could be done without a hitch, but the movement of the fishing gears was slow and the net was on the sea-bottom only for a short time, so the catch was poor.

(e) When the fish shoal is at a certain depth more or less distant from the sea-bottom, two echo-images will be recorded at the same time by the echo-sounder, one being reflected from the fish shoal and the other from the sea-bottom.

Among the fish which are aimed at by the trawl fishing, those which perform a periodic vertical migration such as Alaska pollack, Atka mackerel, and herring can be caught by a rational fishing put into operation after an ecological study of them is made.

(f) The sinking velocity of the fishing gears and the height of the mouth of trawl net can be measured by an echo-sounder.

The author (1952) measured the sinking velocity of the manila rope towing warp and of the fishing gears under operation respectively by an echo-sounder and by an electric resistance depth-meter. The results obtained will be described below (cf. 8 on page 86).

## 2. Vertical distribution and density of various kinds of bottom fish in the sea area northwest of Hokkaido

In the investigation of deep sea fishing grounds in the northern Japan Sea (1949~1954), the author employed echo-sounders of a new type together with the trawl fishing gears to ascertain the vertical distribution and density of various bottom fish in water depths down to 850 meters, and determined the value of a trawl fishing ground in connection with the water depth. According to the results obtained, halibuts and flounders inhabit mostly shallow bottom areas, except only three kinds of them, flat-head flounder, arrow-toothed halibut, and "Urokomegarei", which are more abundant in areas of medium depth; red gurnard, "Kitsunemebaru," Atka mackerel, and "Tsumagurokajika" are mostly found in shallow areas, while the important fish inhabiting deeper areas below 300 meters level are Alaska pollack and cod with which a small amount of "Hatsume" and prawns are found intermingled. Generally speaking, the density of fish population and the number of fish kinds are largest at the depth ranging from 100 to 300 meters and 60% of the marketable fish are caught at that depth. Especially the water depth ranging from the 200 meters line to 150 meters on the one hand and to 220 meters on the other is the place where the density of fish population is maximum. The sea-bottom at a depth of more than 400 meters is only sparsely inhabited by Alasaka pollack, cod and "Hokkokuakaebi" (prawn sp.), so that its value

as a fishing ground declines to the minimum. Moreover, it often becomes to be inhabited entirely by unmarketable fish such as "Urokomegarei", "Abachan", "Genge", "Kasube", etc. The superiority in value as a fishing ground of the sea-bottom area at a depth around 200 meters was proved too by the results of the experiments carried out for a short time in February, May and October. The reason why it is thus superior in that value is perhaps attributable to the fact that the shallower bottom above the 200 meters mud line is suitable for the living of the marine creatures which are the object of the fishery because of the remarkable movement of water and the good penetration of sunlight in that depth which encourage the growth of marine plants, planktonic organisms and larval fish useful as the food of larger fish.

Especially it is conceivable that the upwelling current and eddy turbulence may occur along the continental shelf slope, and thus induced active replacement and circulation of the sea water are considered to promote the propagation of plankton, to improve the growth of the bottom creatures and to increase the amount of food for fish. Moreover it is certain that there is a good effect of the cold current that ascends in summer along the continental shelf slope near the 200 meters depth line. The water temperature near that line is  $3^{\circ}\sim 6^{\circ}\text{C}$  in summer, while is about  $10^{\circ}\text{C}$  at the bottom less than 100 meters in depth.

### 3. Trawl fishing ground on the Musashi Bank and its surrounding waters

Since the discovery in 1925 of the Musashi Bank which lies in the sea northwest of Hokkaido, it has attracted the attention of many people as a new unknown fishing ground, but no study on its value as a trawl fishing ground has hitherto been made. The author carried out investigations of the Musashi Bank and its surrounding waters for 6 years from 1949 to 1954, mainly in summer, and could clarify the whole aspect of the bank as follows :

#### (1) The shape of the sea-bottom and the nature of bottom materials

The Musashi Bank as considered having its base at the 200 meters depth line is a long, narrow, and shallow bank, 57 nautical miles long from north-north-west to south-south-east, with the peak at lat.  $44^{\circ}48'N$ , long.  $140^{\circ}20'E$ . From near the center of the bank projects north-eastward, a shallow branch bank which is called "Tengu no hana" ("that means nose of the long-nosed goblin"). The water area around the bank at a depth less than 100 meters is pentagonal in shape, about 10 nautical miles from south to north and about 8 nautical miles from east to west, having its center at the above noted peak. The water area less than 300 meters in depth is wide from south to north and narrow at the western side of the bank. That is to say, the bank slopes gently at the northern, eastern and southern sides while it slopes rather steeply at the western side. The bottom seems to have no large undulation, though it has small unevennesses scattered here and there. The bottom material is almost entirely rock in the area above 200 meters depth, except for some sandy places

in the eastern part. In the area surrounding the bank the bottom is composed of sand and mud.

(2) The position, shape and bottom material of the shallowest part

According to the result of celo-navigation by the present author, the position of the shallowest part in the Musashi Bank is lat.  $44^{\circ}47'.4N$ , long.  $140^{\circ}20'.5E$ . So its position recorded on Chart No. 41 published by the Hydrographical Department is known to deviate as much as 1.8 nautical miles to the true bearing  $113^{\circ}$  from the real position. According to the judgement of Prof. Yasuo Sasa of the Department of Geology, Faculty of Science, Hokkaido University, the bottom materials collected by a diver from the shallowest part were basalt, pyroxene andesite, lipartie, diorite (or quartz diorite) and other andesite species. The bottom creatures collected were sea-urchins, starfishes, sea-cucumbers, "Hiyorigai" and a kind of kelp, Agarm. *Laminaria* and common abalone were not collected on the bank.

(3) The water area that can be exploited as a trawl fishing ground

From the survey of the sea-bottom by an echo-sounder and the experimental fishing were obtained the following results.

(a) The slopes at the southern, northern and eastern sides of the Musashi Bank are gentle, whilst the western slope is steep and consequently it is narrow, especially so in its northwestern part. In the northern slope of the bank, the bottom is covered with mud above which protrude scattered sharp rocks to cause much hindrance to the trawling. The southern projected part of the bank is also rough on the bottom, so it is not a suitable place for the trawl fishing.

(b) The surface of the bank above the 200 meter line is composed of hard rocks and has small projections and depressions. So, it is unfit for a trawl fishing ground except the eastern bottom near the 200 meter line.

(c) At the depth less than 260~270 meters around the bank, even if the bottom material is known to be sand or mud, the trawling may happen to encounter with some unexpected hitch during the operation, but at a greater depth it may seldom do the same, and the net can be towed safely at a depth of 300 meters and more.

(d) The area which is at a depth less than 260 meters and safe for the trawl fishing lies along the eastern side of the bank, and there will be no hitch even on the bank at a depth of 180~200 meters.

(e) In the area at a depth less than 260 meters surrounding the bank from it south to the north through the west, the fishing is sometimes exposed to a hitch, and special care is needed for an operation at the northern and southern peripheries of the bank.

(4) The distribution of marketable bottom fish and the amount of catch

As regards the distribution of marketable bottom fish around the Musashi Bank, cod, Alaska pollack, Atka mackerel, "Hatsume", flat-head flounder and "Toyamaebi" (a prawn species) are inhabiting all the water areas but not in uniform density. The

kinds of fish which can be caught abundantly in the shallowest area and in the three areas, eastern, southern, and western, of the bank are as follows. "Kitsunemebaru", "Ezomebaru", and Atka mackerel are caught in a large amount in the shallowest parts. Atka mackerel is almost the only kind of fish that can be caught at a depth less than 200 meters on the eastern part of the bank, but with the increase of depth the amount of catch of flat-head flounder and Alaska pollack increases; cod, Alaska pollack, and "Hatsume" are caught in the southern periphery of the bank, Alaska pollack and cod are abundant in the western periphery, and Atka mackerel and "Hatsume" are increasingly caught near the 200 meters line in both the southern and western part of the bank.

As for the amount of catch of each marketable fish kind, Alaska pollack occupies 33% of the total amount while Atka mackerel, cod, and "Hatsume" are similar to each other occupying 14, 15 and 17% respectively. As for the amount of catch at each depth in the sea surrounding the bank, the catch at 240~270 meters depth was largest (22.5%), next followed the catch at the layer of 180~240 meters (16~17.7%), and at depths greater than 210 meters the catch decreased with increasing depth. In all water areas northwest of Hokkaido, the depth of about 200 meters was most rich in the kinds of fish as well as in the amount of catch. However, on the Musashi Bank, the number of fish kinds and the amount of catch were largest in more or less greater depth. This fact may be due to the influence of bottom materials, oceanographical factors and food supply, and perhaps also to the difficulty of trawling near 200 meters depth and at shallower depth because of unfavourable bottom material.

#### 4. Improvement of fishing gears in the one-boat medium trawl fishery

The one-boat medium trawl fishery in Hokkaido and vicinity has been modernized in the construction of its fishing boats and marine engines, and has become to bear the character of pelagic fishery. However, the net is still made of thin cotton twines as in former days, and the shape of net shows no mark of particular progress as compared with that in old days when all of our boats were Japanese style.

The author supervised the manufacture of a new-style fishing net of manila twine in 1950 and 1952, and performed experimental fishings with this net for four years. The results obtained are as follows:

(1) Comparative fishing experiments with the new-style net and with the usual cotton twine net showed that the catch of the fish inhabiting near the sea-bottom such as cod, Alaska pollack, and Atka mackerel by means of the former per one operation on the average was 1.7 times as much as that by means of the latter, and the total amount of catch including those sedentary fish such as halibuts, flounders and "Kajika" by means of the former was 1.4 times, or more, as much as that by means of the latter.

(2) The new-style manila twine net is more bulky, and so it is rather more in-

convenient for handling than the cotton twine net. However, in waters off Hokkaido or in Northern Pacific where the fish shoal is dense, the amount of catch per one haul is large, and moreover the operation is repeated frequently, it is more profitable to employ the manila twine net.

(a) In the improved fishing net, the mouth of the net is widened much more than in the old-style cotton twine net, so as to increase the catching rate of the fish inhabiting near the sea-bottom.

(b) The reason why wire rope is used for the lacing line is that it does not stretch so much even after a long use as a vegetable fiber rope does, and so the change in the "Hopping" of the net is avoided. The wire rope is also good for the reinforcement of the net itself.

(c) The iron pendant swivel is adopted in the improved net instead of the "Tegi" or wooden pole so as to accelerate the sinking velocity of the net, to help untwisting completely the twist given to the net during an operation, and to produce a screen of mud on the sea-bottom when the net is towed.

(d) The ground rope equipped in the improved net is more effective than porcelain sinkers in giving an overall reinforcement to the net and in catching the sedentary fish on the sea-bottom.

(e) The structure of the improved net devised for taking out the catch from the opening at the cod end is far more convenient and efficient than that of the old-style net which necessitates the scooping up of the catch from the mouth of the body net by a dip-net.

##### 5. Determination of the strength of glass ball floats used in the deep-sea fishing

Among the various sorts of net fishing gears, the trawl net used in the one-boat medium trawl fishery is that which is operated in the deepest layer of the sea. Therefore, it matters how strong the glass balls are which are used as floats in that net. According to Kobayashi *et al.* (1951~1954), a glass ball having 1 mm thickness resists the water pressure at a depth of 3000 ~ 4000 meters and that having a 2 mm thick wall resists the pressure at a depth of 6000 ~ 8000 meters. As there is no practical glass ball float with a wall less than 1 mm in thickness, such a thin ball is out of consideration. The present author examined, in an operation at a fishing ground 805~842 meters in depth, the strength of 50 glass balls 12 cm in diameter and learned that the rate of breaking was 8%. This fact has been considered to be explainable from the following characters of the glass ball :

(a) It is not an ideal sphere, (b) the thickness of its wall is not even, (c) air bubbles exist in the glass, (d) residual stress of the glass. Thus the actual strength of the glass ball to resist the pressure is concluded to be smaller than the theoretical strength. Kobayashi *et al.* learned from their experiment that the broken place of the ball was limited to the part of its plug or its immediate neighbourhood, and con-

cluded that the number of breakable glass balls corresponded to 3.9~14.7% of the total with the confidence rate of 98%. These percentages are in agreement with the present author's results. The limit of depth at which one-boat medium trawler can operate is within 800~900 meters for the time being, so the rate of breakage due to the water pressure of the commercial glass ball floats even in an operation at a great depth, can be considered generally to be about 8%.

6. The relation between the amounts of catch and the different ways of casting net

In the one-boat medium trawl fishery, the bottom fish shoal is encircled and caught by two long towing warps and a fishing net attached to them. So, if the towing warps of the same length are employed, it should be profitable to cast a net in a form encircling a larger area. The author (1952~1953) carried out a comparative study employing a towing warp 4000 meters in length between two ways of net casting, viz., in the shape of a regular triangle and of an isosceles triangle (a side is 1600 meters long). The ratio of areas encircled by these triangles is 0.6 for the former and 0.44 for the latter assuming that the area of a regular round is 1. So the amount of the catch should be larger when the warps and net are cast in the shape of a regular triangle than in the shape of an isosceles triangle. Nevertheless, the results of the comparative fishing experiments repeated 38 times showed that the amount of the catch by the net cast in the shape of an isosceles triangle was larger than that by the net cast in the shape of a regular triangle. Such a difference may be due to the fact that in the triangle found by the warps the base to which the net is attached was shorter in the isosceles triangle than in the regular triangle, so the time required in the experiments for bringing the warps towed on the sea-bottom into a parallel position by the power of the advancing boat was 15 minutes in the case of the regular triangle and 10 minutes in the case of the isosceles triangle. In other words, from the start of the boat till the fishing net begins the forward movement, the time elapses faster in the latter case than in the former, so that the escaping rate of the fish within the space enclosed by the warps and net must be smaller in the case of the isosceles triangle which is concluded to give a greater amount of catch.

7. An ideal length of the towing warp in relation to the water depth

In the one-boat medium trawl fishery it is very important to know an ideal length of the towing warp in relation to the water depth, but no experiment has ever been performed by anyone in connection with this kind of problem. The author (1950~1953) operated the experimental fishing 44 times under the same conditions in respect to the fishing gears, the way of net casting and other factors, and examined the relation between the length of towing warp and the depth of water, and the change in the amount of catch. As a result, it was revealed that the amount of catch per one

haul was minimum when the length of the towing warp (one side) was 8 times as large as the depth, and the amount of catch increased rapidly with the rise in the rate of multiplication when the length of warp was up to 9~11 times as large as the depth. If the rate of multiplication becomes more the 11 times, the rate of increase in the amount of catch becomes low. So, the length of the warp must be at least 11 times as large as the water depth. Considering from the fishing efficiency, the ideal length of the warp is concluded to be 13~15 times as large as the water depth.

#### 8. On the sinking velocity of the fishing gears

In the one-boat medium trawl fishery, the fishing boat is advanced when the fishing gears reached to the bottom, and after the net was towed for a certain while the fishing gear is hauled up to catch the bottom fish. So, it is indispensable to know accurately the sinking velocity of the fishing gears for a successful fishing. To this day, fishermen have been convinced from their experience that the gears takes 1 minute to sink down "10 Hiro" ("1 Hiro" or "5 shaku" is equivalent to about 1.5 meters), but no experimental study has been done to prove this.

The author (1950~1952) carried out an experiment for the first time to study the sinking velocity of the fishing gears in the state of a practical operation with complete set of net and warps by means of an electric depth-meter. As a result, the sinking velocity of the fishing gears was revealed to be as follows: (1) 10.6 m/min for the completely dried gears, and (2) 12.5 m/min or "8.5 Hiro"/min for the wet fishing gears.

Another series of experiments to examine by means of an echo-sounder for the sinking velocity of the towing warp only which was made of manila rope and about 2.7 cm in diameter gave the following results: (1) the half dried warp sank at a speed of 13.7 m/min and (2) the wet warp at a speed of 15.6 m/min or "10 Hiro"/min.

The reason why the sinking velocity of the towing warp itself was higher than that of the completely installed fishing gears may be that the former was free from the effect of buoyancy of the glass ball floats attached to the net and that in the experiment of the former case the end of the warp was not attached to the boat.

#### 9. The state of trawl fishing gears during an operation as observed through the window of a submarine observation chamber

Nomura *et al.* (1953) reported the results of their experiments performed by the aid of models on the state of movement during operation of the trawl fishing gears cast into the sea. In the summer of 1953, the author made underwater observations of the fishing gears through the window of the submarine observation chamber "Kuroshio". As a result, he could clarified the following points:

(1) when the bottom fish such as flounders, halibuts and "Kajika" are aimed at, the towing speed need not be more than 1.5 nautical miles per hour until the warps



become parallel, but it is profitable for a good catch to speed up by increasing the rotation of the engine when the warps became almost parallel; (2) the height of the mouth of the one-boat medium trawl fishing net was observed by the author to be a little less than 3.0 meters when the towing speed was 1.5~1.6 nautical miles per hour, while it was observed by Nomura and Yasui (1953) to be 2.5 meters in their experiment by the aid of a model, thus both of those two observations gave a similar result; (3) on the sea-bottom consisting of fine sand, the turbidity of water near the bottom caused by the passing of the towing warp expanded as high as 0.5 meter from the bottom and that caused by the passing of the fishing net expanded as high as about 5 meters.

10. Comparative superiority of the two sides of a boat as a place to operate the fishing gears on the one-boat medium trawler

The ordinary fishing boats in Japan usually operate their fishing gears on the portside from a custom kept since the days of scull and oar. The trawlers are not exceptions as a whole. In the modern one-boat medium trawlers which are steered with a right handed single screw-propeller and rudder, it is considered from the navigation theory more profitable to operate on the starboard because the screw current generated by the screw can be utilized effectively.

The author carried out a number of experiments during a period ranging for 6 years on board the training ship "Hokusei-maru" (104 Ts, 210 H.P.), and could ascertain that it was profitable to operate on the starboard side because the fishing gears were in no danger of being entangled with the propeller and the steerage of the boat at the time of net hauling was without any difficulty.

11. Ecological studies on fish shoal by an echo-sounder and an application of their results on fishing

Ecological studies on various kinds of fish by an echo-sounder have recently become to be carried out by several investigations. The author (1951~1952) made ecological observations of the Alaska pollack shoal at the Alaska pollack fishing ground in Ishikari Bay, Hokkaido, and conducted experiments on the application of the ecological data to the trawl fishing as well as to the long-line fishing ("Haenawa-fishing"). The shoal of Alaska pollack which comes into Ishikari Bay makes its appearance in its migratory season from 8 o'clock to 10 o'clock in the morning in the middle layer of the sea as a horizontal belt-shaped shoal. It begins to sink gradually from about noon, reaches the bottom at about 2.00 p.m. and stays there until 5.00~7.00 p.m. Then the afternoon would be the time when the catch of fish by trawl nets is good. It was clarified by images on the recording paper of an echo-sounder that the shoal which appeared at first in the shape of a belt in the middle depth of water divided then into two to three layers, and after reaching the bottom became dispersed.

If the fishing net is cast at this very time, the amount of catch can be expected to be abundant. After one to several days, the shoal appears again in the middle water layer in the shape of a belt, and the above described phenomena are repeated. When the shoal is at the sea-bottom, conditions are suitable for a profitable trawl fishing, but when it is at the middle layer of the sea, conditions are good for the long-line fishing ("Haenawa-fishing").

In a shoal divided into two layers, the fish of the upper layer are male, and those of the lower layer are female.

Taking advantage of those phenomena, a trawl fishing can expect the maximum catch by the minimum labour, and a long-line fishing will be possible to angle at a suitable time either male or female fish at will.

The aforementioned are the general conclusions of the scientific investigations carried out with the object of learning the reasonable method of searching a new fishing ground, the ideal fishing gears and the rational fishing techniques, which have all hitherto been quite imperfectly pursued from custom and by fishermen's intuition. Those conclusions are believed to be applicable readily to the practical fishing.

#### LITERATURE CITED

- Aikawa, H. (1948). Suizoku-seitai-gaku-gairon. [*Out-line of marine ecology.*] Tōyō-shokan, Tokyo, 227p. (in Japanese).
- Aikawa, H. (1949). Suisan-shigen-gaku-sōron. [*Science of marine resources.*] Sangyōtoshō, Tokyo, 551 p. (in Japanese).
- Fukutomi, T. *et al.* (1950). [Oceanographical investigation in summer 1949, in the sea northwest of Hokkaido.] ("*Hokutū-nihonkai-shinkai-gyoden-chōsa-hōkoku*"). (1), 33-78. Otaru. (in Japanese).
- Hazaki, M. (1941). [Deep sea fishing experiment] 44-53. *Prog. Rep. Nagasaki Fish. Exp. Sta.* 1941. (in Japanese).
- Hanai, I. (1943). [On the deep sea fishing ground.] *Prog. Rep. Hokkaido Fish. Sci. Inst.* (582), 11. (in Japanese).
- Hashimoto, T. (1951). Study of the ultrasonic echo-sounder, fish-finder and its application. *Fishing Boat Series II*. 150 p. Fisheries Agency, Tokyo. (in Japanese with English abstract).
- Hikita, T. & Misu, H. (1952). (Fishes collected by trawl fishing off the northwest coast of Hokkaido.) ("*Hokubū-nihonkai-shinkai-gyodenchōsa hōkoku*"). (3), 5-70, Otaru. (in Japanese).
- Imai, H. *et al.* (1953). [Report on the deep fishing ground in the west of Rebun Island, Hokkaido.] *Branch S'a. Hokkaido Fish. Sci. Ins.*, Wakkanai. 65 p. (mimeogr.) (in Japanese).
- Inoue, N. & Sasaki, T. (1953). [Report on the diving investigations with "Kuroshio", Undersea Observation Chamber.] *Sci. Res. Ins.* Tokyo. 72p. (in Japanese).
- Kuwada, T. (1939). [*Collection of treaties by Kōsuke Kunishi.*] Maruzen Tokyo. 1230p. (in Japanese).
- Kuwahara, A. & Chino, S. (1946). [*Method of treatment of a recording echo-sounder.*] Hydrog. Dept. Jap. Navy.
- Kamohara, T. (1949). *Shinkai-no-gyozoku. [Deep sea fishes.]* Nipponshuppan-sha, 202 p. Osaka. (in Japanese).
- Kato. (1949). [Chart of the deep sea fishing ground in the northern Japan sea.] (*unpublished*). Hydrog. Off. M.S.B. Jap.
- Kato, K. & Okuda, T. (1950). Studies on Marine Sediments One of Environmental Factors of

- Fishing Ground in the Sea to the Northwest of Hokkaido. ("Hokubu-nihonkai-shinkai-gyoden-chōsa-hōkoku") (1), 15-35. Otaru. (in Japanese).
- Kumagori, T. (1950). [Echo-sounder and fish-finder.] *Gyosen (Fishing boat), Jap. Fish. Boat. Ass.* (52), 243-250. (in Japanese).
- Kobayashi, K. Takahashi, H. & Ueno, M. (1951). Studies on glass ball float. *Bull. Fac. Fish. Hokkaido Univ.* 1 (2), 102-110. (in Japanese with English abstract).
- Kimura, K. Iwashita, M. & Hattori, I. (1952). Image of skip-jack and tuna recorded on echo-sounding machine. *Bull. Tōhoku Reg. Fish. Res. Lab.* (1), 15-19. (in Japanese with English abstract).
- Koike, A. (1953). Model experiments on a Teiso-hikiami (trawl net). *Bull. Jap. Soc. Sci. Fish.* 19 (1), 8-11. (in Japanese with English abstract).
- "Kii-suidō-okiai-sokouo-shigen-chosa. [Investigation on the bottom fish off Kii Channel.] (1953). *Fac. Agr. Nagoya Univ. and Aichi Pref. Fish. Exp. Sta. Quart. Rep.* I, 32p. (in Japanese).
- Miyamoto, H. (1936). Model experiments on trawl nets. *Bull. Jap. Soc. Sci. Fish.* 5 (1), 19-24. (in Japanese with English abstract).
- Moor, H.B. (1950). The relation between the scuttering layer and the Euphausiacea. *Biol. Bull.* 99 (2), 181-212.
- Mozai, T. (1953). [Echo-sounder]. Kaibun-do. Kobe. 122p. (in Japanese).
- Nomura, M. & Yasui, Y. (1953). Model Experiments on trawl nets of various type. *Bull. Jap. Soc. Sci. Fish.* 18 (12), 727-733. (in Japanese with English abstract).
- Ogaki, K. *et al.* (1952). [Investigations on deep sea fishing ground off Kitami District, Hokkaido.] *Hokkaido Fish. Sci. Inst.* 67p. (in Japanese).
- Owatari, A. Furuno, K. & Furuno K.K. (1953a). The behavior of the horse mackerel schools recorded by fish-detector. *Bull. Jap. Soc. Sci. Fish.* 18 (8), 362-264. (in Japanese with English abstract).
- Owatari, A. Furuno, K. & Furuno, K.K. (1953b). The behaviors of the sardine schools by fish-detector. *Ibid.* 18 (12), 669-674. (in Japanese with English abstract).
- Kaiyo-sha, (1941). [Seamanship] II. Tokyo 145p. (in Japanese).
- Shirai, K. *et al.* (1922-1925). [Investigations on bottom fishing ground in the Pacific Ocean.] *Hokkaido Fish. Sci. Inst.* 26p. (in Japanese).
- Shirai, K. *et al.* (1923-1925). [Investigations on bottom fishing ground in the Japan Sea.] *Ibid.* 36p. (in Japanese).
- Shirai, K. & Imaizumi, K. (1925-1926). [Investigations on fishing ground on Musashi Bank, north Japan Sea.] *Ibid.* 43p. (in Japanese).
- Sakai, M. & Uno, M. (1943). [Fishing experiment of deep sea] *Suisan-kenkyu-shi. (a Journal of Fisheries).* 38 (10), 6-12. (in Japanese).
- Saito, I. (1949). *Trawl Fishery.* 368p. Maruzen. Tokyo. (in Japanese).
- Saito, I. (1950 a). Investigations on trawl fishing ground adjacent to Aomori Prefecture. *Rep. Surv. Mari. Reso. Aomori. Pref.* (1), 15-28. (in Japanese).
- Saito, I. & Mishima, S. (1950 b). Studies on fishing ground, fishing gears and fishing technique in one-boat medium trawl fishing. ("Hokubu-nihonkai-shinkai-gyoden-chōsa-hōkoku"). (2), 7-57. Otaru. (in Japanese).
- Saito, I. & Mishima, S. (1951 a). Breaking ratio of glass ball floats in deep waters. *Ibid.* (2), 56-57. (in Japanese).
- Saito, I. & Mishima, S. (1951 b). Survey on bottom fishing ground and devices of gear and operation of one-boat medium trawl. *Ibid.* (3), 9-107. (in Japanese).
- Saito, I. (1951 c). Sinking velocity of towing warp and net (One-boat medium trawl). *Rep. Sur. Mar. Res. Aomori Pref.* (3), 1-3. (in Japanese).
- Saito, I. & Fujii, T. (1953 a). Observation on sea-bottom inhabiting fish and invertebrates on the shallowest part on Musashi Bank. ("Hokubu-nihonkai-shinkai-gyoden-chōsa-hōkoku"). (4), 53-55. (in Japanese).
- Saito, I. & *et al.* (1953 b). On the operation of one-boat medium trawl fishing. *Ibid.* (4), 33-51. (in Japanese).

- Saito, I. & Mishima, S. (1953 c). Studies on detection of plankton by echo-sounder (or fish-finder) and selection of fishing station in a fishing ground. *Bull. Fac. Fish. Hokkaido Univ.* 3(4), 269-272. (in Japanese with English abstract).
- Saito, I. & *et al.* (1953 d). On the migration of Pacific saury (*Cololabis saira*) in Tsugaru Straits. (1), *Ibid.* 3 (4), 273-276. (in Japanese with English abstract).
- Saito, I. & Uruguchi, Y. (1954). Observations on Alaska pollack shoals in the fishing ground off Yoichi, Hokkaido. ('*Hokubu-nihonkai-shinkai-gyoden-chōsa-hōkoku*'). (4), 29-30. (in Japanese).
- Saruta, T. *et al.* (1952). Model experiments on drag net. Part 1. *Bull. Tōhoku Reg. Fish. Res. Lab.* (1), 35-42. (in Japanese with English abstract).
- Tester, A.L. (1943). Locating hering with an echo sounder. *Prog. Rep. Fish. Res. Bd. Canada* (55), 4-6.
- Tomabechi, Y. (1950). [Topography and deposits in the sea northwestward from Hokkaido]. ('*Hokubu-nihonkai-shinkai-gyoden-chōsa-hōkoku*'). (1), 1-14. (in Japanese).
- Tōhoku Regional Fisheries Research Laboratory. (1951). Kaiyo-shigen-nenpo. (*Annual Report marine resources*) 1951; (Bottom Fish). (4), 115 p. (in Japanese).
- Tabata, K. (1953). [Report on exploratory trawl fishing in deep region off Ishikawa Prefecture.] *Ishikawa Fish, Exp. Sta.* 1953. 6p. (in Japanese).
- Takakura, T. (1954). The behavior of the spawning pollack schools recorded by fish-detector. *Bull. Jap. Soc. Sci. Fish.* 20 (1), 10-12. (in Japanese with English abstract).
- Uda, M. (1939). Umi [*The Sea*]. Asahi-shin-kōza. (29) 266p. Asahi-shinbun-sha, Tokyo. (in Japanese).
- Uda, M. (1952). [Advancement of marine ecology promoted by the studies on ultrasonic waves.] *Kagaku.* 22 (2), 78-83. (in Japanese).
- Yokota, T. (1953). [Studies on sardines in Hyūga-nada and Bungo channel.] *Rep. Nankai Reg. Fish. Res. Lab.* (2). 251p. (in Japanese).