



Title	ECOLOGICAL STUDIES ON THE GROWTH AND FOOD CONSUMPTION OF JAPANESE COMMON LITTORAL SEA URCHIN, STRONGYLOCENTROTUS INTERMEDIUS (A. AGASSIZ)
Author(s)	FUJI, Akira
Citation	MEMOIRS OF THE FACULTY OF FISHERIES HOKKAIDO UNIVERSITY, 15(2), 83-160
Issue Date	1967-12
Doc URL	http://hdl.handle.net/2115/21847
Type	bulletin (article)
File Information	15(2)_P83-160.pdf



[Instructions for use](#)

**ECOLOGICAL STUDIES ON THE GROWTH AND FOOD
 CONSUMPTION OF JAPANESE COMMON LITTORAL
 SEA URCHIN, *STRONGYLOCENTROTUS*
INTERMEDIUS (A. AGASSIZ)**

by

Akira FUJI

Faculty of Fisheries, Hokkaido University

Contents

	Page
I. Introduction	84
II. Materials and General method	86
1. The localities where sampling was performed	86
2. Aquarium tanks used in this study	87
3. Measurement of sea urchin body	89
III. Gonad growth and Body growth	89
1. Gonad growth	90
a) Annual changes in gonad growth in the adult population	90
b) Relation of gonad growth to size	93
2. Body growth	95
a) Linear growth and age determination	95
b) Growth rate	100
c) Relationship of weight to size	104
d) Variation in weight of the non-gonad tissue with successive growth of the test	107
IV. Food habits and Nutrition absorption	111
1. Food habits	112
a) Composition and quantity of the gut contents	112
b) Feeding activity	114
c) Amount of food taken in by the sea urchin	119
2. Nutrition absorption	121
a) Transport of food mass through the gut with digestive and feeding processes	121
b) Food assimilation	126
V. Rate of production and Protein metabolism	130
1. Food conversion	131
a) Growth efficiency	132
b) Annual energy budget	133
2. Utilization of protein nitrogen for growth	139
3. Food required for maintenance	142
a) Replacement amount of food	143
b) Endogenous nitrogen excretion	145
VI. General considerations	148
VII. Summary	154
References	157

I. Introduction

Up to the present, the five following species belonging to genus *Strongylocentrotidae* have been the species of commercial importance for sea urchin fishing in Japan;

Strongylocentrotus intermedius (A. Agassiz)

Strongylocentrotus nudus (A. Agassiz)

Hemicentrotus pulcherrimus (A. Agassiz)

Anthocidaris crassispira (A. Agassiz)

Pseudocentrotus depressus (A. Agassiz)

The first two species are abundant in northern Japan from northern Tohoku District to northern Hokkaido. The last three species are commonly found along the rocky shores of Japan, from southern Tohoku District to southern Kyushu.

In recent years, as shown in Table 1, the annual yield of the sea urchin from Japan has amounted to as much as about 20,000 tons, and approximately 50 per cent of the total catch has been taken from Hokkaido and about 20 per cent has been caught along the Sanriku coast, Iwate and Miyagi Prefectures. Consequently, it will be understood that sea urchin fishing in Japan has depended mainly upon *Strongylocentrotus intermedius* and *Strongylocentrotus nudus*, the species of northern Japan.

Several attempts at the propagation of the Japanese sea urchin had been performed along the coast of Oita, Nagasaki and Fukui Prefectures (Shimura, 1924; Kawana, 1935, 1938 a; Minamizawa & Ogawa, 1955, 1957, 1958). Although such attempts were performed on the basis of biological information, just how much such attempts will add to the total catch of sea urchin remains an open question. This uncertainty may be attributed to the fact that very little is known about the ecology of the sea urchin, although a voluminous literature dealing with the physiology of fertilization and the embryology of the sea urchin is available. Echinoides have been used by man as food in the coastal region along the Mediterranean (Harvey, 1956) and in the British West Indies (Lewis, 1958), but they are not commonly used in other parts of the world. Therefore, on foreign species of the sea urchin, the studies made from the standpoint of sea urchin fishing are very scarce. Intensive studies on its ecological aspects are also scanty.

The recent development of sea urchin fishing in Japan has brought about apprehensions concerning the effect of heavy fishing on the stock and has caused people to consider limiting the catch to conserve the resources (Kinoshita, 1958; Nakamura & Yoshinaga, 1962). Now, it is evident that either protection or artificial propagation is required to maintain their number at the present level. To do this it is necessary to understand entire ecology of the sea urchin. The basic functions of the organism—its growth, reproduction, development and so forth—all take place at the expense of the energy which enters the organism in the form of its food.

Table 1. Annual yield (ton) of sea urchins in Japan from 1954 to 1963. Data were derived from the Fisheries statistics which was edited by Ministry of Agriculture and Forestry of Japanese Government.

Prefecture	1954	1955	1956	1957	1958	1959	1960	1961	1962	1963
Hokkaido	3030	4590	3201	4193	6164	7854	8883	7776	7583	8861
Aomori	195	340	94	240	290	433	450	308	734	707
Iwate	1920	1840	2600	1751	1846	1644	2389	3196	2042	2373
Miyagi	644	1192	1138	842	1033	1506	1651	1096	1668	1689
Fukushima	45	41	64	41	81	77	80	68	62	89
Ibaragi	22	41	37	30	23	22	12	8	13	16
Kanagawa	4	—	—	4	6	7	46	22	27	16
Aichi	—	7	15	7	12	10	33	10	9	10
Mie	26	37	68	68	63	137	193	111	145	96
Fukui	127	146	124	94	137	197	133	139	84	182
Kyoto	—	—	26	19	13	17	13	2	6	17
Hyogo	11	30	30	22	—	6	12	5	10	20
Tottori	68	41	37	60	28	38	22	60	65	112
Shimane	19	34	7	7	8	24	32	34	13	97
Yamaguchi	83	416	519	740	879	469	457	713	856	562
Wakayama	7	4	—	4	3	2	3	4	1	1
Okayama	—	—	—	—	40	—	—	—	—	—
Tokushima	19	26	—	4	14	18	39	184	164	112
Kagawa	4	—	—	—	15	9	11	17	8	2
Ehime	—	—	—	—	4	46	96	83	153	239
Fukuoka	4	4	11	—	17	34	30	43	26	15
Oita	11	—	—	15	23	50	43	33	55	16
Saga	—	22	4	19	66	156	64	104	166	186
Nagasaki	226	214	702	495	940	682	631	977	848	1376
Kumamoto	7	98	334	459	520	460	451	722	1549	2207
Kagoshima	—	—	—	—	34	50	62	121	145	335
Miyazaki	11	15	7	15	13	8	19	12	29	48
Total	6483	9138	9018	9128	12272	13956	15855	15865	16477	19302

Consequently, their life cycle is the leading problem in understanding the ecology of the sea urchin. This field of study, however, has not yet been intensively investigated. Further systematic study in this field may provide important clues necessary in setting a reasonable limit to the catch, conservation of resources and propagation of the sea urchin.

From the above viewpoint, a series of investigations has been carried out by the present author since 1956 on the ecology of the sea urchin, *Strongylocentrotus intermedius*, which is one of the species of commercial importance in Japan. The results of the series of investigations are described in the principal part of this report. The results of this study are not complete enough to be directly applicable to increasing sea urchin production, but these findings will be basic to further investigations.

The present report includes ecological and bio-economical observations on the growth, feeding, and incorporation of nutrients into the body of the sea urchin. It also includes an outline of their life cycle. The growth of an organism is the augmentation of the constituents of the organism's body and is due to the con-

sumption of food. So in the present investigation, first, before dealing with food consumption and nutrition, the growth phenomena of the body and of the gonad were observed. All energy processes within the organism proceed at the expense of the food. Consequently, in the next part, food habits, feeding activity, and feeding amounts are explained in detail, and the energy flow and protein metabolism are examined to clarify the metabolic processes of the sea urchin. Besides these, some experiments were performed to determine the amount of food required for maintenance and the nitrogen balance. And finally, I tried to outline their life cycle categorized according to their metabolic processes.

Before going further, the author wishes to express his heartiest thanks to Prof. Tadashi Tamura of the Faculty of Fisheries, Hokkaido University, for kindly reading this manuscript. The writer also desires to acknowledge his great indebtedness to Prof. Shinjiro Kobayashi and Prof. Kiichiro Yamamoto of the same Faculty, Hokkaido University, for their untiring encouragement throughout the course of the present study. Cordial thanks are due to Assistant Prof. Hikoei Ohmi and Assistant Prof. Hiroshi Yabu of the same Faculty of Hokkaido University, for guidance on the ecology and identification of sea-weeds used as food materials for the sea urchin. He also is deeply grateful to Dr. Yoshio Hasegawa and Mr. Sangoro Shibuya of the Hokkaido Fishery Research Laboratory at Yoichi, for the use of their facilities at Usu Bay. Acknowledgement is also due to Messrs. Yusho Ogawa, Yoshiaki Tanaka, Keikei Maruyama, Teruhiko Awakura, for the supply of living animals used in the present study. The author wish to express his thanks to the staff members of Sapporo District Meteorological Observatory for supplying the climatic data.

II. Materials and General Method

The data obtained in the present investigation comes from two sources. The first is the data based on observations of the natural population of the sea urchin, and the second is the data supplied from experiments under aquarium conditions. The geographical locations where samples were taken and the aquarium tank employed in the present study are described to elucidate the fundamental factors limiting the experimental observations. Other methods employed in this study will be explained in each section.

1. The localities where sampling was performed

Some of the sea urchins used in this study were collected at regular intervals and others at arbitrary times from many localities along the coast of southern Hokkaido, between 1956 and 1962. Figure 1 shows the localities where sampling was performed. These localities are divided into three regions according to geographical position; (1) the coast of Volcano Bay — Muroran, Usu, Ishiya and Mori,

(2) the coast of the Tugaru Straits — Shinori, and Sumiyoshi in Hakodate, and (3) the coast of the Japan Sea — Setana. Of these localities, Ishiya, Usu and Sumiyoshi were chosen for the observations of the food habits of the sea urchin. However, the samples for the observations of body growth and of gonad development were collected from all above mentioned localities.

Adult sea urchins were collected by means of a scoop-net from the shore in places which were 1- to 3-meters deep. Young sea urchins were picked up at random by hand on the rocky shore during the night or morning low tides because of the difficulty of collecting from the bottom where the water is 1- to 3- meters deep due to the roughness of the bottom and to its algal cover.

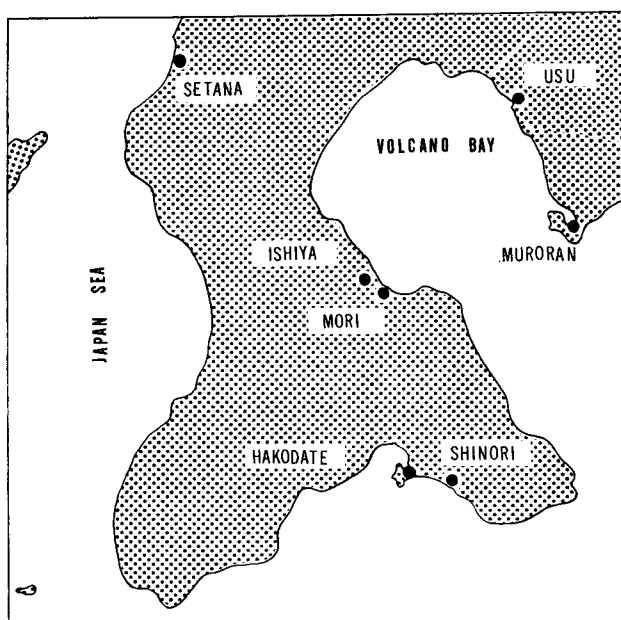

Figure 1. Sketch-map of southern Hokkaido, showing the localities where sampling was performed

2. Aquarium tanks used in this study

Rearing experiments were performed in aquariums of 40- and 60-liter capacity, with recirculatory sea water systems. Two systems were used. One was an air lift for circulation of aquarium water, and the other employed a feed-pump for the same purpose. These forms for the circulation of the water are illustrated in Figures 2 and 3. The first system consists of an aquarium and a filter-chamber, which contains sea sand as filtratory substance. The water filtered through the filter-chamber flows into the aquarium tank by air bubbles through an air lift. As the aquarium water is connected to the water in the filter-chamber by a siphon, the same quantity of the aquarium water returns to the filter-chamber through the

siphon. So, the sea water in the aquarium is continuously circulated, filtered, and aerated by streams of air bubbles. The second system consists of four main peices of equipment; they are an upper tank and filter-chamber, an aquarium, an under thank and filter-chamber, and a feed-pump for circulation of the water. Aquarium water, overflowing from a constant level siphon, is led to the under tank through the under filter-chamber, and from here it is shifted to the upper tank through the feed-pipe by the feed-pump. Then, the water is supplied to the aquarium through another feed-pipe. The upper tank has a float-switch, which can open and close the electric circuit. This electric circuit is opened when the

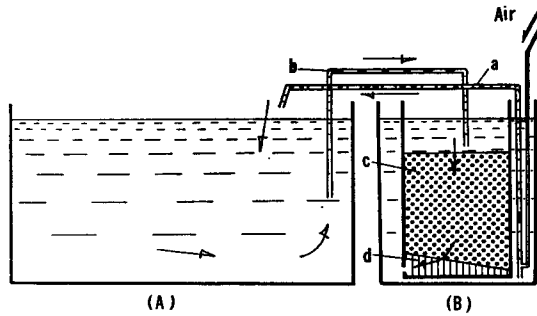

Figure 2. Diagrammatic illustration of rearing aquarium with a recirculating sea water system. (A): Aquarium, (B): Filtering chamber, a: Air lift, b: Siphon, c: Sea sand, d: Glass wool. The arrows indicate the circulation of rearing sea water.

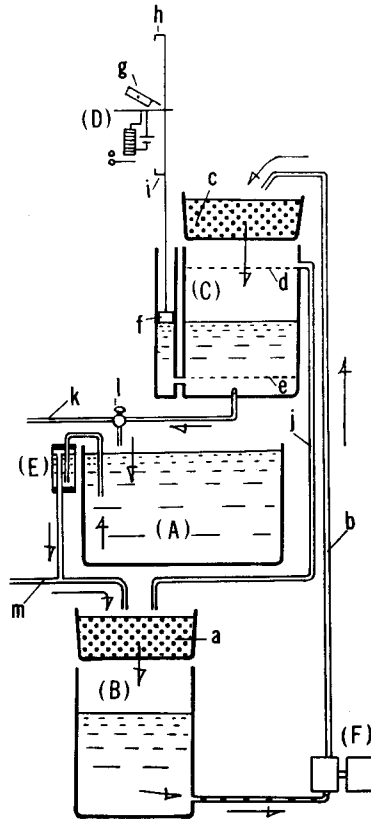

Figure 3. Diagrammatic illustration of rearing aquarium with other system for circulation of aquarium water. (A): Aquarium, (B): Under tank, (C): Upper tank, (D): Relay, (E): Constant level outflow, (F): Feed-pump, a: Under filtering chamber, b: Feed-pipe, c: Upper filtering chamber, d: Upper level of water in tank, e: Under level of water in tank, f: Float, g: Mercury switch, h: Bar for closing an electric circuit, i: Bar for opening an electric circuit, j: Overflow pipe, k: Feed-pipe, l: Stop-cock, m: Water-shoot.

water level in the upper tank rises to some definite upper level, and is closed at when it drops to some definite lower level. Operation of the feed-pump is automatically regulated by the motion of the float-switch. Accordingly, the water level in the upper tank is always between the upper and lower levels, and supplying the water to the aquaria continues without any interruption. The present apparatus used in the author's laboratory is illustrated in Figure 3.

During the rearing experiments, a quantity of sea water was siphoned out together with the faecal pellets which settled on the bottom of the aquarium. The water removed in this process was replaced with new sea water. The sea urchin which were brought into the laboratory aquarium adapted to aquarium life quickly and soon learned to recognize food when it was placed in the tank.

3. Measurement of sea urchin body

The methods of measurement used are as follows; *Diameter* is the length of the median line of the test passing through the anus. *Height* is the distance from the peristome to the periproct, and this distance corresponds to the linear distance between the anus and the lip. The diameter and the height were measured with sliding calipers with a knife-edge on each jaw. Total weight of the sea urchin was measured after leaving it for about 10 minutes on an absorbent towel. To calculate the volume each specimen was immersed into a small vessel (10×10×15 cm) filled with sea water, and the water which overflowed from the vessel was measured as the total volume of the sea urchin. As the immersion of the whole body of a small urchin in a vessel filled with sea water displaces only a small quantity of water, a small amount of error (within 2%) in measuring the total volume is unavoidable.

III. Gonad Growth and Body Growth

In general, the life of an organism is roughly divided into two aspects, biological production and energy supplement. Biological production includes the body growth which involves survival of the individual and includes the gonad growth which involves continuation of the species. Energy supplement is directly connected to food consumption. It has been well known that the amount and kind of food varies with their age and the season. Therefore, it is necessary to clarify facts about the body growth and the gonadal development, before studying food consumption.

The outstanding papers of the last 40 years on the growth of the test of various species in a number of different genera fall into three categories, (1) size-frequency analysis of natural population (Elmherist, 1922; Moore, 1934, 1935, 1936; Nataf, 1954; Lewis, 1958; Swan, 1958, 1961), (2) measurement of individuals reared under laboratory conditions (Bull, 1938; Swan, 1961), and (3) interpretation of measurable characteristics (Kume, 1929; Moore, 1935). They clarify the relation between age and diameter, however no available information has been published on the increase in each tissue of the sea urchin's body with progressive growth and with seasonal variation. Moreover, despite the fact that *Strongylocentrotus intermedius* occurs in suitable habitats throughout much of northern Japan, the growth pattern and the age composition of this creature have not yet been published.

Information on the gonad growth of the sea urchin is based on one or both of the following; (1) seasonal variations in the gonad weight or volume (Stott, 1931; Moore, 1934, 1935; Bennett & Giese, 1955; Lewis, 1958; Fuji, 1960 a; Kawamura, 1960; Moore et al., 1963; Giese et al., 1964; McPherson, 1965), (2) cytological and histological observations of the gametogenic development (Tennent et al., 1931; Tennent & Ito, 1941; Fuji, 1960 a,c; Kawamura, 1960). The above studies on gonad growth were mainly performed to determine the spawning season. However, there is virtually no published systematic information on the changes in volume of the gonad.

This chapter, firstly, deals with some basic information about the gonad growth during the entire course of life of *Strongylocentrotus intermedius*. Secondly, I have undertaken to fill in some of the existing gaps in knowledge concerning the growth pattern and the age composition of the sea urchin. This study is based on the data of the size-frequency distribution of the sea urchins collected from the coast of southern Hokkaido and on the data of the rearing experiment performed in a laboratory aquarium.

1. Gonad growth

Regular and arbitrary samples of sea urchins from the adult population (over 40 mm in diameter) were obtained at regular intervals from Shinori, Ishiya, and Muroran in southern Hokkaido, between June 1956 and March 1959. The collections were usually made from depths of 1 to 3 meters by means of a scoop-net. Samples of smaller urchins (under 30 mm in diameter) were picked up by hand at various times between June 1957 and November 1958, from the rocky shores of Ishiya and Muroran.

Each sea urchin was dissected, after its diameter and its volume were measured. Aristotle's lantern of each specimen was removed, five gonadal tissues were removed with care so as to avoid any damage and water adhering to the gonad surface was removed by blotting with absorbent paper.

(a) Annual changes in gonad growth in the adult population

The following experiment was designed to learn how the gonad weight changes with progressive months of the year. If the gonad weight, which changes with development and depression of gametes, is employed as a suitable unit for assessing the gonad growth, it is necessary that the specimens of a similar degree of gonad maturity have a similar value irrespective of their size. Gonad index derived from the following formula is suitable as an unit for assessing the voluminal change with progressive gonad growth (Fuji, 1960 a). The formula is: $GI = \frac{GW}{TV} \times 100$ in which GI is the value of the gonad index, GW is the wet weight of the gonad in grams and TV is the total volume of the sea urchin in milliliters. An average of the gonad indexes of the sea urchin group represents the degree of group maturity of this animal.

Figure 4 shows how the gonad indexes of male and female adult sea urchins vary at different seasons of the year. From the above figure, it can be noticed that the average gonad index throughout the year, especially from September to January, varies considerably. The gonad index reaches a peak value in August and September. The minimum value (ca. 5–10) was obtained from animals collected in October and November. After these months the value increases slightly, reaching approximately 15 in January or February. Gradual increment of the index value continue steadily during the months between February and May. The value of the gonad index begins to increase strongly from June or July followed by the peak in August. This seasonal pattern of the gonad index is similar among the sea urchins collected from all localities chosen in this observation.

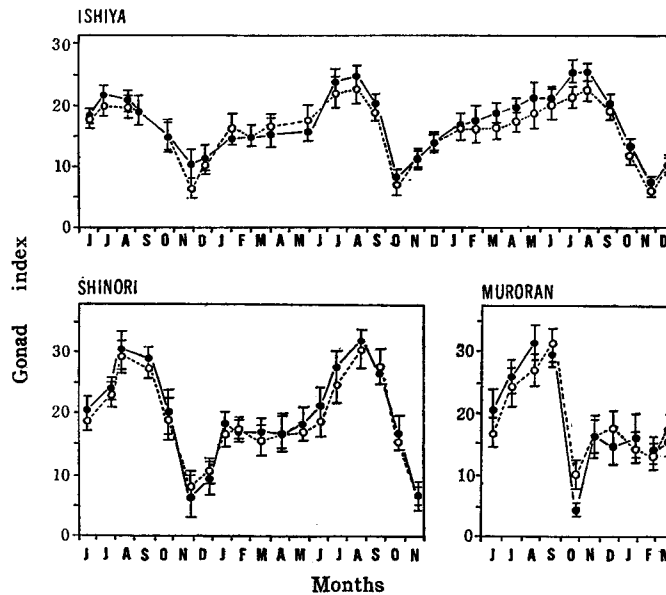

Figure 4. Cyclic changes of the gonad index in both sexes. Each vertical bar indicates the range of plus or minus in standard error of mean.
○: Male population, ●: Female population.

In describing the gametogenesis in male and female sea urchins, it is convenient to establish a series of arbitrary but easily recognizable stages in its cycle. Seven stages including development and depletion of gonads were categorized in conformity with the previous work of the present author (Fuji, 1960 a), these being determined in the main by the predominating cell within a follicle in company with the superficial appearance of the gonads, 1) *Neuter stage*, 2) *Developing stage*, 3) *Recovering stage*, 4) *Growing stage*, 5) *Pre-mature stage*, 6) *Mature stage*, and 7) *Spent stage*. Of these stages, the gametogenic cycle of the adult sea urchin consists

of five stages of gametogenic activity; there are *Recovering stage*, *Growing stage*, *Pre-mature stage*, *Mature stage* and *Spent stage*. Each percentage of the five stages of gonadal development and depletion is plotted against the successive months, and the processes of cyclic changes of gametogenesis are summarized as follows. In August and September, individuals of *Mature stage* appear rather frequently (50–70%), then the number decreases rapidly until November. Beginning in September the number of spent animals increases greatly and attains a maximum (40–60%) in November. After this month, simultaneously with the gradual diminution of the spent individuals, the animals in the *Recovering stage* become numerous; nearly half of the animals collected in January possess *Recovering* gonad. After January, a diminution of animals in the *Recovering* stage is accompanied by a gradual augmentation of *Growing stage* and *Pre-mature* animals.

It has already been mentioned that the annual cyclic changes of the gonad index have been accompanied by development and depression of gametes (Fuji, 1960 a). In view of the fact that the seasonal changes of the gonad index are concomitant with the variations in the development of gametes, all things considered, the

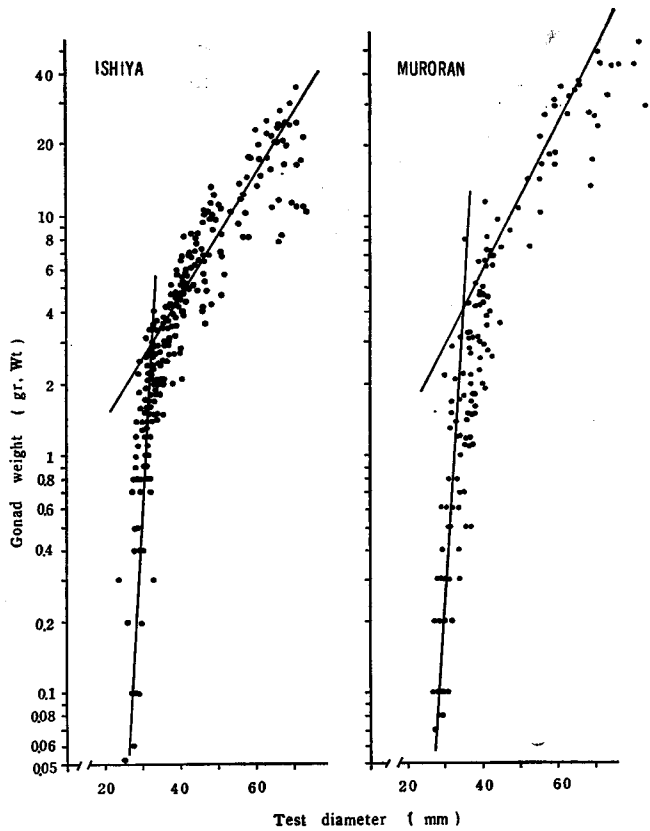

Figure 5. Relation of gonad weight to diameter of sea urchins collected in September

annual gonad growth in the adult sea urchin of this species may be roughly divided into the following four different phases; (1) *Recovering phase* (November—February), (2) *Growing phase* (March—May), (3) *Maturing phase* (September—October).

(b) Relation of gonad growth to size

The breeding season of the present species of the sea urchin in southern Hokkaido is prolonged, beginning in early August. The reproductive process falls clearly into a single reproductive cycle with the peak of spawning in October or November, although the breeding commence at somewhat different times in different localities (Fuji, 1960 c). Therefore, it is convenient to use the specimens collected in September, which corresponds to the term of maximum gonad development in adult sea urchins, to discover the profile of gonad growth of sea urchins of all sizes.

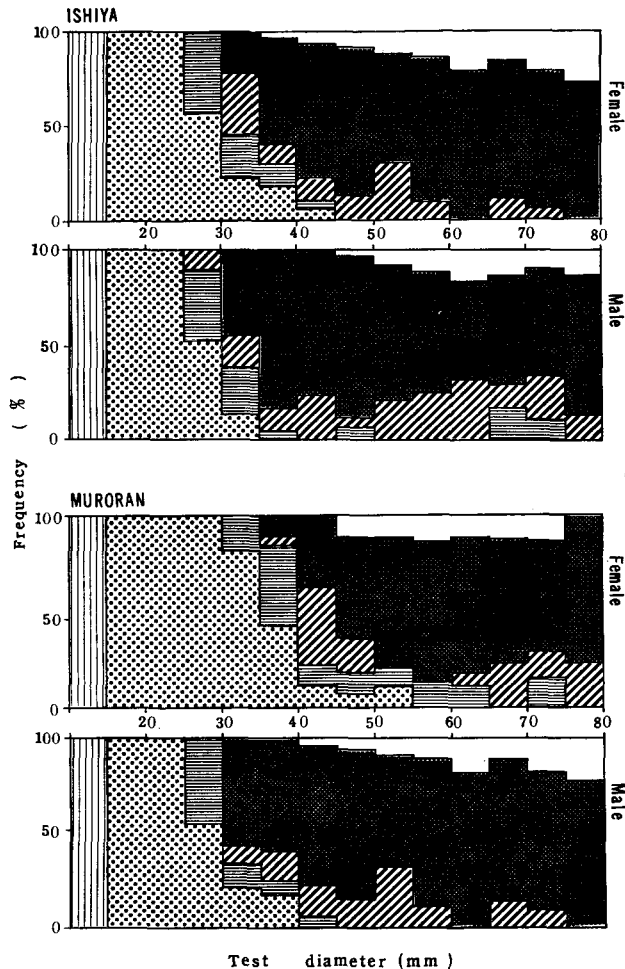

Figure 6. Histograms showing the relation between body size and gonad maturity (From Fuji, 1960 b). : Recovering stage, : Growing stage, : Pre-mature stage, : Mature stage, : Spent stage.

Sea urchins ranging from 23 mm to 74 mm in diameter were taken from Ishiya and Muroran during September, 1958, and their gonads were weighed (wet weight). The relationship between test diameter and gonad weight can be clearly seen by plotting the data for each individual (Figure 5). In the above figure, two exponential curves intersect at the gonad weight of the specimen of about 32 mm or 35 mm in diameter. This shows that the gonad growth pattern of the sea urchin population under 35 mm in diameter differs from that of the specimens which are more than 35 mm in diameter. According to the results obtained from the histological observation of the gonad (Fuji, 1960 b), more than 50 per cent of specimens over 35 mm in diameter possess mature gonads, and they differ markedly from smaller sea urchins in possessing a high proportion (ca. 70% at least) of the early developing gonad (Figure 6). Consequently, the size of sea urchins when they first become sexually mature ranges between 30 mm and 35 mm. There is a rather sudden appearance and development of gonads at this diameter.

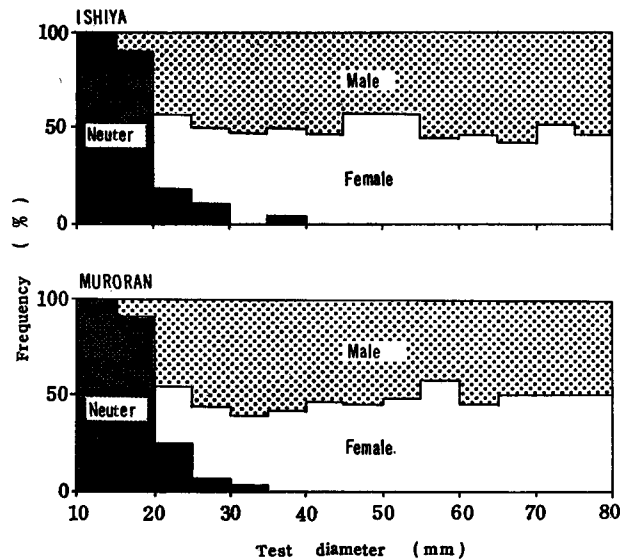

Figure 7. The percentage frequency of neuter, male and female urchins collected in September (From Fuji, 1960 b)

From the previous report (Fuji, 1960 b), which showed the frequencies of neuter, male and female urchins collected in September, the time of maximum gonad development in adults, it was pointed out that almost all specimens (more than 80%) 20 mm in diameter or less possess neuter gonad (Figure 7). By comparing Figure 6 and Figure 7, it can be seen that some discrepancy exists between the size at first sexual maturity and the size of sex differentiation. The size-groups of 20 to 30 mm in diameter possess a high proportion (ca. 70% at least) of the early

developing gonad (*Recovering stage* and *Growing stage*) even in September. Accordingly, it is extremely probable that the specimens of these size-groups remain virgin without developing to the mature gonad till the following breeding season.

Combing the above information, it may be suggested that the gonad growth consists of three different stages throughout the entire life. The first stage is found in young specimens less than 20 mm in diameter. This is the primary gonad stage. At this time it is impossible to discern any sex difference, and there is virtually no growth. The second stage covers the development from immaturity to first maturity. This process occurs once, not annually. Gonad growth is slow in this stage. The third corresponds to the process of the gonad development of adult sea urchins. In this process, the gonad development shows the annual cyclical change, which consists of four different phases; *Recovering phase*, *Growing phase*, *Maturing phase* and *Breeding phase*.

2. Body growth

To determine the growth rate and age, two methods were employed; one was an analysis of the size-frequency distribution of the natural population, and the other was based on periodic measurements of animals reared in the laboratory aquarium.

Adult and young sea urchins used for this purpose were collected by a scoop-net from depths of 1- to 3-meters at Ishiya, along the coast of Volcano Bay, and Sumiyoshi in Hakodate. This method of collecting is liable to result in an incomplete representation of the smaller members because of the roughness of the sea bottom and its algal cover. In so far as possible, the sea urchins available in an area of 10×200 meters were picked up by hand from the 0.7 meter deep rocky shore at Ishiya during the night or morning low tides in October, 1959, 1960 and 1961.

The rearing experiments were performed in 40- and 60-liter aquaria, to which recirculatory sea water system were applied.

(a) Linear growth and Age determination

The diameter was measured with sliding calipers accurate to one-tenth of a millimeter. The measurements were divided into each group representing a range of 2-mm. Then the frequency of each group was represented as percentage. The polymodal frequency distribution obtained was graphically analysed making use of probability graph paper devised by Harding (1949). Each normal distribution, which was separated from the polymodal frequency distribution, was compared with ordinal frequency under the statistical treatment of chi-square test, and was tested for the goodness of the fit.

The size-frequency distribution of each group is represented in Figure 8, together with several fitted normal curves which were calculated by this method. From this figure, it can be pointed out that three or four size-groups were separated

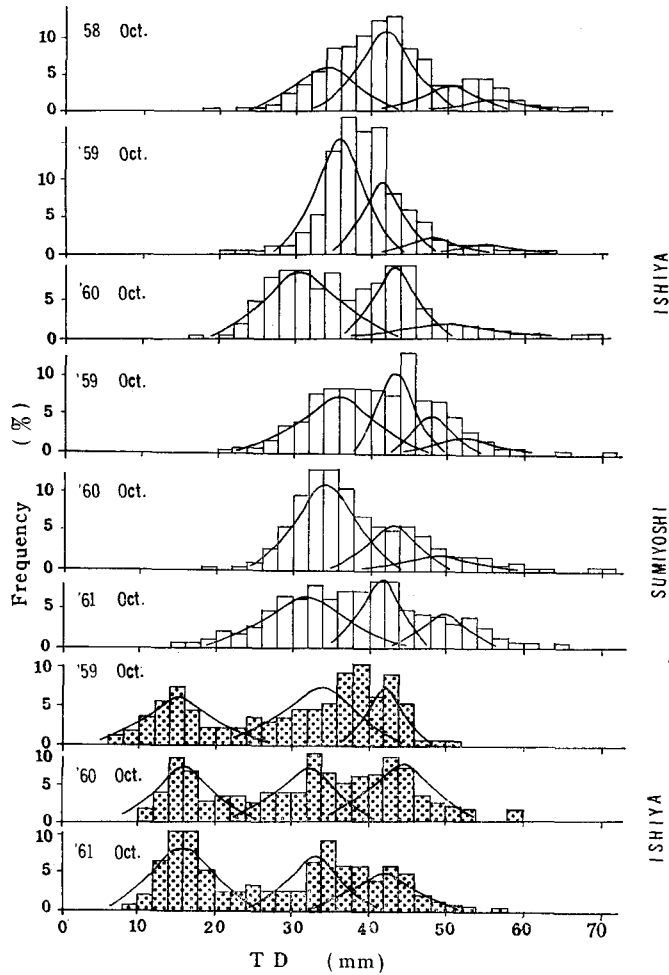

Figure 8. Histograms showing the frequency of diameter and several fitted normal curves calculated by the probability graph pair method. □: Samples collected by a scoop-net, ▨: Samples collected by hand.

from the frequency distribution in each case. Although the mean value of each separate group varies slightly from year to year, and from one locality to another, the size-groups are always centered about the same mean diameters. Clearly defined modes were not found for the large sized urchins. This may be due to the overlapping of large size groups resulting from variation of growth and subsequent obliteration of the modes. In the month of October 1958, the sea urchin population collected by a scoop-net at Ishiya consisted of four size-groups: the mean diameters of these groups were calculated at 34.0, 42.1, 50.3 and 55.3 mm respectively. In 1959, the mean diameters of four size-groups computed were 35.8, 41.6, 47.7 and 54.1 mm. These values coincide with those of the October before.

Moreover, the population collected from Sumiyoshi was separated into four size-groups showing similar tendencies, their mean diameters were 36.4, 43.2, 48.0 and 52.0 mm in the month of October, 1959. These values are similar to those of 1958. On the other hand, the sea urchin population picked up by hand from the rocky shore of Ishiya consists of three different size-groups, and their mean diameters in the month of October each year were approximately 16, 33, and 44 mm respectively. From the results of Figure 8, it can be seen that the mean diameters of the second and the third groups correspond with those of the first and the second groups which were separated from the frequency distribution of the population collected by a scoop-net.

From the analysis of the size-frequency distribution, it may be said that the sea urchin population in the month of October consisted of five groups; the mean diameter of the first group is estimated at about 17 mm; the mean diameters of the second, the third, the fourth, and the fifth groups are approximately 33, 43, 50 and 55 mm respectively. The mean diameters of the five different groups were summarized in Table 2.

Table 2. Mean diameter (mm) estimated from several fitted normal curves.
Each roman number indicates the respective size-group.

Loc.	Year	No.	Size-groups				
			I	II	III	IV	V
Ishiya	'58 Oct.	335	—	34.0±4.2	42.1±2.9	50.3±3.9	55.3±5.0
	'59 Oct.	285	—	35.8±3.0	41.6±2.5	47.7±3.3	54.1±3.7
	'60 Oct.	309	—	30.6±5.0	42.9±2.5	49.2±7.7	—
Sumiyoshi	'59 Oct.	289	—	34.6±5.0	43.2±2.0	48.0±2.0	52.0±4.4
	'60 Oct.	419	—	33.2±4.0	43.1±3.0	49.8±7.4	—
	'61 Oct.	325	—	31.5±5.5	41.6±2.4	49.6±2.7	58.1±5.9
Ishiya	'59 Oct.	168	15.0±4.5	33.4±4.6	42.0±2.0	—	—
	'60 Oct.	157	16.0±4.0	32.4±3.8	45.2±4.4	—	—
	'61 Oct.	151	16.1±4.0	32.8±3.3	42.0±4.4	—	—

In October 1961, animals of various sizes were collected from Ishiya. The sizes of the animals at the beginning of the experiment were selected on the basis of size-frequency mdoes as mentioned in Table 2. They were arranged in four size-groups of 8 to 13 specimens each, and were reared in aquaria to which applied recirculatory sea water systems. They were given a sufficient food (*Laminaria japonica*) supply. The specimens which entered to the population in the former October or November, were collected from Ishiya on February 22, 1962. They, also, were reared in aquaria with conditions similar to those mentioned above. On October 30, 1962, nearly a year after the initiation of this experiment, the diameter of each specimen was measured. The data obtained is summarized in

Table 3. Growth of *Strongylocentrotus intermedius* reared in aquaria with *Laminaria japonica*

Beginning of exp.			End of exp.		
Date	No.	Dia. (imm)	Date	No.	Dia. (mm)
1961 Oct., 22	8	51.6±3.1	1962 Oct., 30	8	55.5±3.1
1961 Oct., 22	8	43.8±2.1	1962 Oct., 30	8	48.9±2.3
1961 Oct., 22	11	35.7±1.8	1962 Oct., 30	11	43.0±0.7
1961 Oct., 22	13	12.7±0.8	1962 Oct., 30	13	35.7±0.8
1962 Feb., 22	7	2.9±0.7	1962 Oct., 30	7	14.8±1.1

Table 3. The smallest size-group grew to a mean diameter of approximately 15 mm, and this value closely corresponds with the mean diameter for the next size-group at the initiation of this experiment. Moreover, this value coincides with the mean diameter of the first size-group, separated from the size-frequency distribution of the natural population. This strongly suggests that the five different size-groups separated from the frequency distribution correspond to successive age-groups.

The co-ordinates of growth profile are some expression or index of size against time. Growth from includes some knowledge which provides a sort of general statement about its total structural development, or such physiological indexes as basal metabolic rate respiration rate, and so forth, and which makes possible to understand the total metabolic relationships. Up to the present, some equations for the growth profile have been proposed (Kubo & Yoshihara, 1957; Aikawa, 1960), however, each formula has its own peculiarities which give it advantages and limitations not possessed by others. The relationship between age and diameter shown in Table 2 reveals an S-shaped growth curve. This implies merely that initial growth is slow, intermediate growth more rapid, and later growth is slow again. Growth curves in sigmoid or S-shaped fashion are usually represented by the following equations; (1) Robertson's formula, (2) Gompertz's formula, and (3) Bertalanffy's formula. The mathematical treatment of the data shown in Table 2 can be based on the regression of D_{t+1} on D_t . Where D_t equals the means diameter at each age t . Walford's graphs using the three above equations are shown in

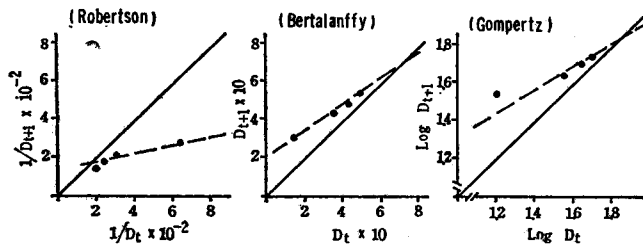

Figure 9. Walford's graphs using the formula of Robertson, Bertalanffy and Gompertz

Figure 9. From Walford's graphs it is suggested that Robertoson's formula is suitable for the growth curve of younger urchins, but that it fails where applied to older ones. The actual observation corresponds closely with the regression line itself for Bertalanffy's equation.

A suitable exponential formula of the body length to age, established on general physiological principles by Bertalanffy (1938, 1949) is

$$l_t = l_\infty (1 - e^{-kt})$$

where l_t is the body length at any time t , l_∞ is the ultimate body length, and k is a constant. Since this formula is better than the other logistic curves, it has been usually applied for the growth curve of the fish population (Sato, 1953; Bagenal, 1955; Shiraishi, 1961). This formula is also found to be applicable to this species of sea urchin.

Using the data in Table 2 this formula was computed by the least square method for curve fitting devised by Deming (1943). Then, the equation became:

$$D_t = 69.200 (1 - e^{-0.331(t-0.219)})$$

In this formula, the corrective value (0.219 years) of t corresponds to the time from birth to metamorphosis. Under laboratory conditions, *Arbacia punctulata* takes three or four months from fertilization through metamorphosis (Harvey, 1956), and

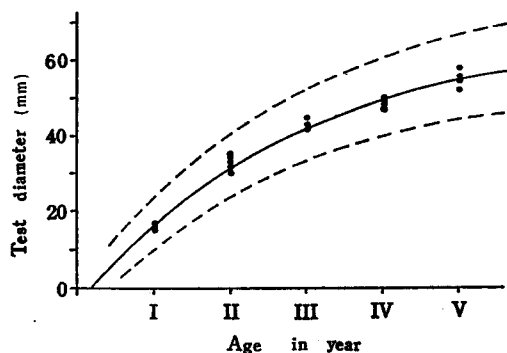

Figure 10. Diagram showing the theoretical growth curve and observatory values in diameter. Dots are the observatory value. The upper and lower dotted lines represent 95% confidence limit of the theoretical curve.

Pseudocentrotus depressus takes about two months (Yamabe, 1962). The 95 per cent confidence limits of D and k are +6.61 and +0.036 respectively. The chi-squared test shows that the formula have a probability of more than 90 per cent ($\Pr\{\chi^2 > 0.211\} = 0.90$). The 95 per cent confidence interval of the growth curve of *Strongylocentrotus intermedius* was shown in Figure 10 and Table 4, together with the diameter for each age-group. From the above formula, the mean diameter of each age-group was determined. They are as follows: approximately 16, 31, 42, 49

Table 4. Theoretical diameter and total weight at various ages. 95% confidence limit from the mean is shown in parentheses.

Age	Observed	Calculated	
	Test diameter (mm)	Test diameter (mm)	Total weight (gr)
I	15.70	15.78 (21.99—9.57)	1.75 (5.31—0.16)
II	33.14	30.82 (39.38—22.26)	12.45 (17.82—8.55)
III	42.63	41.64 (51.44—32.84)	30.20 (34.41—26.41)
IV	49.14	49.40 (60.02—38.78)	49.87 (57.11—43.55)
V	54.87	54.98 (66.07—43.89)	68.31 (85.07—54.89)

and 55 mm at the age of full 1-, 2-, 3-, 4- and 5-years. Where, the animals less than 12 months old were designated 0-year-old group, those between 12 and 24 months old were designated 1-year-old group, and so on.

(b) Growth rate

To determine the rate of growth the diameter and height of the five different age-groups were measured each month for a year. These measurements are listed in Table 5. Their mean values are graphically illustrated in Figure 11. From this, the increase in size of each group for each month was transformed into a percentage of the initial dimensions for comparison, because the degree of growth varied among the different size-groups. These values were expressed in terms of a monthly growth rate, and were histogramatically demonstrated in Figure 12. From this figure it can be seen that the most rapid growth takes place in the young urchin and that the growth rate falls off as they get older. The zero-year-old group

Table 5. Growth data in five age-groups reared

Date	IV (N=8)			III (N=8)		
	D (mm)	H (mm)	TW (gr)	D (mm)	H (mm)	TW (gr)
'61, Oct., 22	51.6±3.1	27.9±1.9	56.6±8.9	43.8±2.1	23.1±1.9	37.2±6.1
Nov., 28	52.2±2.9	28.2±2.0	56.8±8.9	44.1±3.2	23.3±2.0	37.1±6.7
Dec., 27	52.8±3.0	28.6±1.9	57.8±9.6	45.0±1.8	23.7±1.9	38.3±8.1
'62, Jan., 27	53.7±3.6	29.0±1.8	59.0±10.1	45.7±2.2	24.1±2.0	39.9±7.0
Feb., 22	54.8±3.4	29.4±2.0	60.8±8.9	46.8±1.5	24.9±2.0	41.5±7.2
Mar., 22	55.1±3.6	29.9±1.8	62.0±9.6	47.3±1.6	25.0±2.2	43.6±7.3
Apr., 24	55.2±3.4	30.1±1.7	63.1±10.6	48.4±1.5	25.3±2.2	45.7±7.4
May, 24	55.2±3.5	30.1±1.6	64.5±11.8	48.4±2.7	25.3±2.3	47.3±7.4
June, 28	55.3±1.7	30.1±1.8	64.9±9.4	48.4±2.6	25.4±1.0	48.3±7.6
July, 28	55.3±2.9	30.1±2.0	65.5±8.9	48.4±2.1	25.4±2.9	48.7±7.7
Aug., 31	55.3±2.2	30.1±1.9	65.7±10.1	48.4±1.9	25.4±1.0	49.0±8.0
Sept., 24	55.4±2.7	30.1±2.0	65.8±9.8	48.6±2.3	25.4±1.9	49.1±6.9
Oct., 30	55.5±3.1	30.2±1.8	65.9±9.1	48.9±2.3	25.6±2.1	49.3±7.1
Nov., 22	55.8±3.3	30.4±1.9	66.1±10.0	49.2±1.7	25.8±2.1	49.5±6.8
Dec., 28	56.2±2.9	30.6±1.7	66.6±9.8	49.8±2.6	26.1±2.0	50.5±7.0
'63, Jan., 31	57.1±3.0	30.8±1.9	67.5±9.6	50.6±2.3	26.4±2.0	51.7±7.2

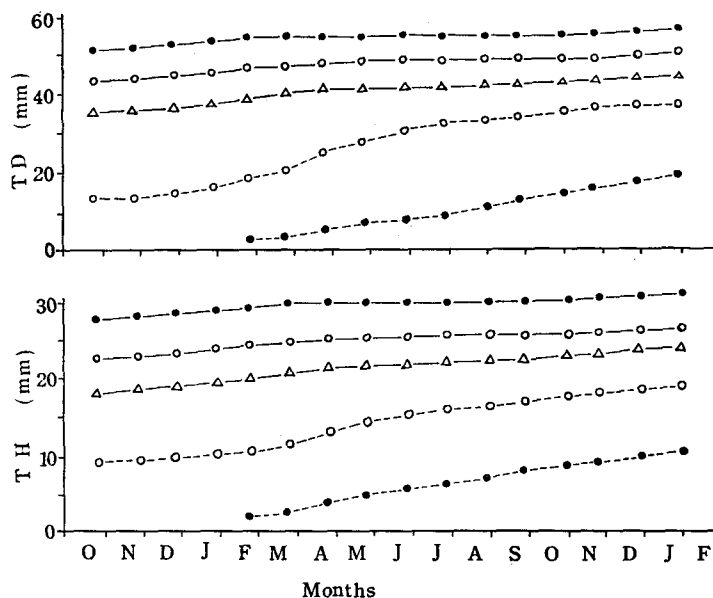

Figure 11. Increases of the diameter and the test height with successive months.
 ---●---: 0-year-old animals, ---○---: 1-year-old animals, —△—: 2-year-old animals, —○—: 3-year-old animals, —●—: 4-year-old animals.

grew continuously with a monthly growth rate of 10 to 30 per cent throughout the year. The growth of the 1-year-old group took place steadily through the entire year, although their monthly growth rate remained at about half that of the 0-year-old group. For the 2-year-old group the growth rate was at a still lower level, and

in aquaria with *Laminaria japonica*

II (N=11)			I (N=13)			O (N=7)	
D (mm)	H (mm)	TW (gr)	D (mm)	H (mm)	TW (gr)	D (mm)	H (mm)
35.7±1.8	18.4±0.6	19.1±2.2	12.7±0.8	9.2±0.8	0.8±0.4	—	—
36.0±1.4	18.6±0.6	19.9±2.7	13.7±1.1	9.5±1.0	1.0±0.4	—	—
36.7±2.2	18.9±0.6	20.9±2.6	14.8±0.9	9.9±0.9	1.4±0.8	—	—
37.7±1.3	19.4±0.7	22.5±2.6	16.6±1.3	10.4±1.1	2.0±0.8	—	—
38.7±1.4	20.0±1.0	24.1±2.0	18.6±0.2	11.1±0.8	3.0±0.8	2.9±0.7	2.0±0.4
40.2±1.1	20.8±0.9	26.7±2.7	20.8±0.7	12.0±1.4	4.2±0.5	3.9±0.7	2.8±0.4
41.0±1.1	21.5±0.9	29.5±2.8	24.7±0.2	13.1±1.3	6.8±0.7	5.3±0.7	3.9±0.3
41.2±1.5	21.6±0.8	32.1±2.9	27.8±1.0	14.4±0.8	9.8±0.6	6.7±0.7	4.8±0.5
41.2±1.5	21.7±0.8	33.1±3.4	30.3±0.4	15.4±0.7	12.0±1.1	8.2±0.6	5.5±0.5
41.8±1.3	21.9±1.0	33.3±2.8	31.8±0.2	16.1±1.0	13.8±0.7	9.3±0.8	6.1±0.4
42.5±1.0	22.1±1.1	33.6±3.0	32.9±0.7	16.6±1.4	15.4±0.8	11.4±0.9	7.1±0.6
42.8±1.1	22.2±0.7	33.8±2.5	34.1±0.5	16.9±1.5	16.6±0.6	13.0±1.2	7.8±0.8
43.0±0.7	22.8±1.5	34.0±2.6	35.7±0.8	17.4±0.5	18.2±1.4	14.8±1.1	8.6±0.8
43.5±0.7	23.1±1.8	35.1±1.3	36.5±0.9	17.7±0.5	19.4±0.9	16.0±1.1	9.1±0.7
43.9±0.6	23.5±0.8	36.0±2.3	36.8±1.0	18.3±0.6	20.7±0.9	17.7±1.2	9.7±0.9
44.6±0.8	23.9±0.7	37.2±2.0	37.7±0.9	19.0±0.4	22.3±0.4	19.2±1.0	10.3±0.9

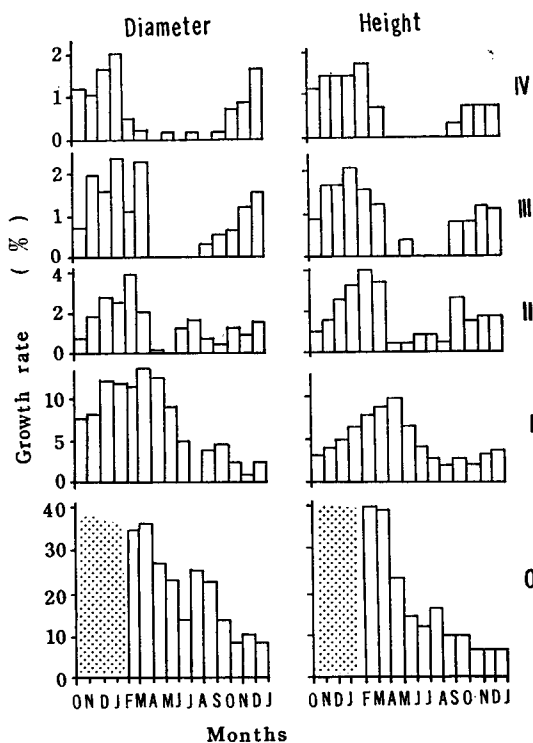

Figure 12. Seasonal changes of the monthly growth rate for five different age-groups. Roman number in right side of each figure indicates age-group.

growth stopped for a period in late spring and early summer. In adult urchins of more than three years old it should be noted that the growth period was very short, lasting only for about four months in the winter, and that growth almost ceased for the rest of the year. These characteristics of growth were noticed alike in both height and diameter. Seasonal development of the gonad in the young age group is almost nil, and their growth continues steadily throughout the year. The older age group, however, have full size gonads between June and September when their growth ceases almost completely. Combining this data, Figures 6 and 12 probably show that the sudden decrease in growth in the older age groups is associated with the remarkable growth of gonad.

The relation of the diameter to the height in different seasons of the year of the *Strongylocentrotus intermedius* collected at Ishiya was studied (Table 6). The comparison of the regression formulae were done statistically using the test of significance of slope difference and positional difference of some allometry lines (Reeve, 1940; Ito, 1951, 1953; Kubo & Yoshihara, 1957). No significances in slope and in position were recognized among the regressions for the different seasons (Table 7). These relationships are graphically summarized in Figure 13.

Table 6. Regression formulae showing the relation of diameter to height in different seasons of the year

Season	Number of animal	Regression formula
Feb.	20	$H=0.5244 D-0.3811$
Apr.	21	$H=0.5188 D-0.1727$
June	23	$H=0.5202 D-0.2347$
Aug.	25	$H=0.5099 D-0.1980$
Oct.	24	$H=0.5166 D-0.2163$
Dec.	23	$H=0.5228 D-0.2452$

Table 7. Analysis of variance of the regression formulae showed in Table 6

Reduce form	SS	f	V	F_0 F
Separate line	214.02	124	1.728	1.716 < 2.29
Slope diff.	13.81	5	2.962	
Parallel lines	230.83	129		
Parallel lines	230.83	129	1.789	2.005 < 2.29
Positional diff.	17.94	5	3.588	
Single line	248.77	134		

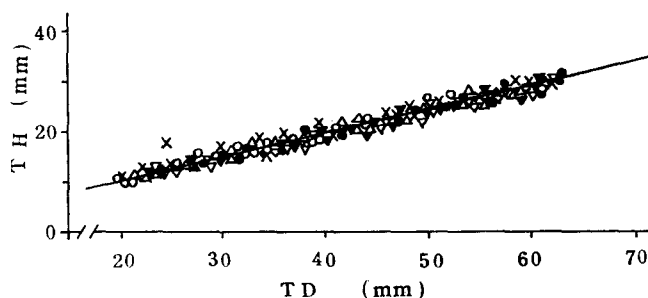
Figure 13. Relationship between diameter and test height in different seasons.
 Δ : Feb., ∇ : Apr., \circ : June, \times : Aug., \blacktriangledown : Oct., \bullet : Dec.Table 8. Regression formulae showing the relation of diameter to height of *Strongylocentrotus intermedius* collected from different localities

Locality	Number of animal	Regression formula
Muroran	45	$H=0.5842 D-2.4543$
Usu	47	$H=0.5258 D-0.1133$
Setana	54	$H=0.5483 D-2.3216$
Ishiya	48	$H=0.5425 D+0.2075$
Mori	50	$H=0.5193 D-0.6748$
Sumiyoshi	53	$H=0.5283 D-1.3586$

Such findings may suggest that this population has an inherent relationship of height to diameter. Similar results were obtained from studying the relationships of diameter to height of animals collected from different localities in southern Hokkaido (Tables 8 & 9). The above findings concerning the linear growth show that the test height varies proportionally to the diameter and over all size. The general shape is the same throughout their life.

Table 9. Analysis of variance of the regression formulae showed in Table 8

Reduce form	SS	f	V	F ₀ F
Separate line	849.49	323	2.6300	1.935 < 3.06
Slope diff.	30.54	6	5.0900	
Parallel lines	880.03	329		
Parallel lines	880.03	329	2.6749	2.912 < 3.06
Positional diff.	46.73	6	7.7883	
Single line	926.76	335		

(c) Relationship of weight to size

The diameter — weight relationship of the sea urchins between 23 mm to 72 mm in diameter was determined during September, 1961. The total weight was determined from the observed diameter by the application of the following formula: $W = aD^n$ Where W is the total weight in grams, and D is the diameter in millimeters. The above relationship is expressed in the formulae shown in Table 10. When these regression lines were compared by the test of significance of slope and positional difference, no significant difference was found among various localities (Table 11). Then, it was found that $W = 0.0005272 D^{2.9373}$ or $\log W = 2.9373 \log D - 3.2770$ is the regression formula for the pooled sample. Deviation from regression was calculated to be 0.2094, and thereby it is possible to know the total weight corresponding to any diameter with a 95 per cent confidence limit. Table 4 showed the average diameter and average total weight of each age group with a 95 per cent confidence limit. The growth curves are shown in Figure 14.

Table 10. Regression formulae showing the relationship between diameter (mm) and total weight (gr) of *Strongylocentrotus intermedius* collected from different localities

Locality	Numbr of animal	Regression formula
Muroran	25	$\log W = 2.8946 \log D - 3.1859$
Usu	22	$\log W = 2.9844 \log D - 3.3421$
Setana	24	$\log W = 2.8246 \log D - 3.1231$
Ishiya	23	$\log W = 2.7243 \log D - 3.3488$
Mori	24	$\log W = 2.8385 \log D - 3.1006$
Sumiyoshi	19	$\log W = 2.6655 \log D - 2.8421$

Table 11. Analysis of variance of the regression formulae showed in Table 10

Reduce form	SS	f	V	F ₀ F
Separate line	0.3613	146	0.00247	1.186 < 2.92
Slope diff.	0.0176	6	0.00293	
Parallel lines	0.3789	152		
Parallel lines	0.3789	152	0.00249	1.148 < 2.92
Positional diff.	0.0172	6	0.00286	
Single line	0.3961	158		

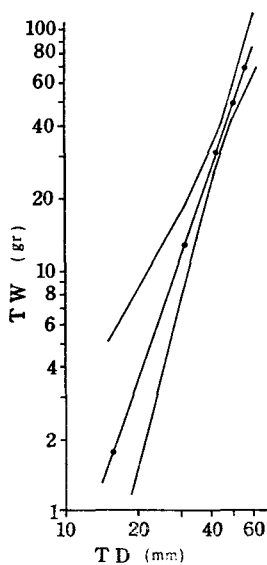

Figure 14. Relationship between diameter and total body weight. The upper and lower curves represent 95% confidence limit of the regression line.

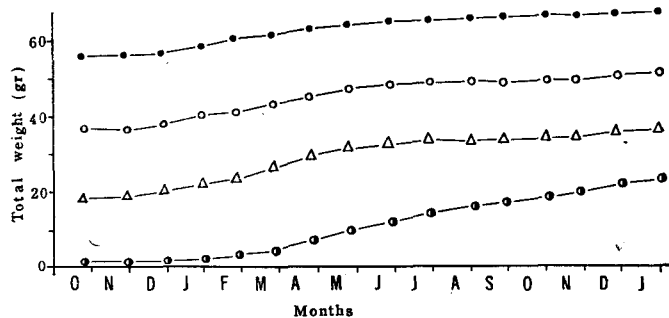

Figure 15. Growth curves in weight of the sea urchins. ●: 1-year-old animals, △: 2-year-old animals, ○: 3-year-old animals, ●: 4-year-old animals.

Figure 15 shows graphically the seasonal variations in body weight under aquarium conditions. It can be clearly seen by comparing Figure 12 with Figure 16 that the profile of the increase in body weight with successive months has a strong resemblance to the profile of the monthly linear growth rate. The months between November and March when the rapid growth takes place corresponds closely to the months when their body weight increases rapidly. It has been already demonstrated that the months between July and September belong to the pre- and uncompletion-spawning period, and that the completion of spawning occurs in the month of November (Fuji, 1960 c). From this we might expect a

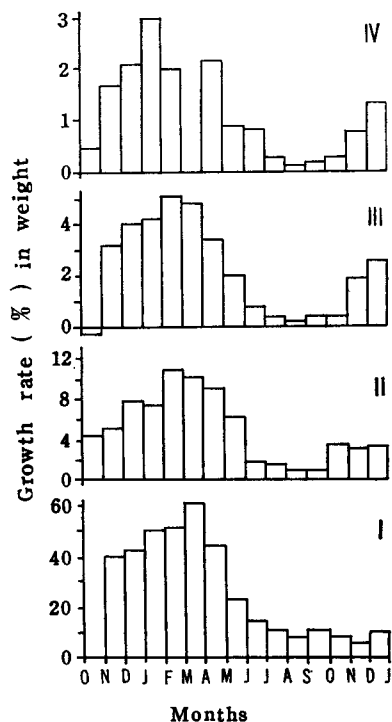

Figure 16. Seasonal changes of the monthly growth rate in total weight of the sea urchins. Roman letter in right side of each figure is the same as those in Figure 12.

decrease in their body weight in the autumn because of the decrease in the weight of the gonad due to the ejection of gametes. However, we did not find any decrease in the body weight, even in the older age groups. The relationship between the diameter and the body weight is shown in Table 12, where the regression lines were determined for the sea urchins which were collected bimonthly from Ishiya. No significant difference was found in the above relation in different seasons (Table 13). This fact differs from the results obtained from shellfish (Ino, 1953;

Table 12. Regression formulae showing the relation between diameter and total weight of *Strongylocentrotus intermedius* in different seasons of the year

Season	Number of animal	Regression formula
Feb.	20	$\log W = 2.7353 \log D - 2.9603$
Apr.	22	$\log W = 2.7766 \log D - 3.0155$
June	23	$\log W = 2.7025 \log D - 2.8978$
Aug.	25	$\log W = 2.6524 \log D - 2.8378$
Oct.	24	$\log W = 2.6585 \log D - 2.8516$
Dec.	23	$\log W = 2.4178 \log D - 2.4432$

Table 13. Analysis of variance of the regression formulae showed in Table 12

Reduce form	SS	f	V	F ₀ F
Separate line	0.5630	125	0.0045	1.511 < 2.29
Slope diff.	0.0341	5	0.0068	
Parallel lines	0.5971	130		
Parallel lines	0.5971	130	0.0046	2.022 < 2.29
Positional diff.	0.0465	5	0.0093	
Single lines	0.6436	135		

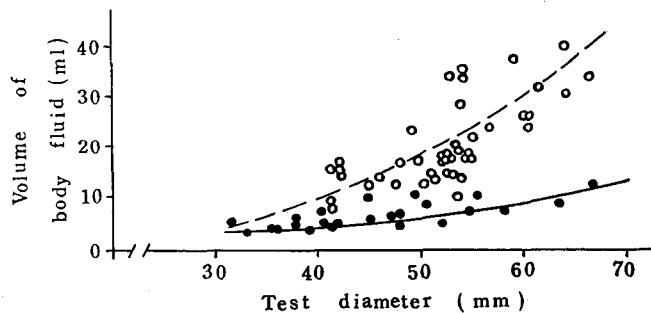
Figure 17. Change in the volume of perivisceral fluid with increasing diameter.
○: Dec., 22. (From spent urchins), ●: Sept., 19. (From gravid urchins).

Kuenzler, 1961; Sakai, 1962) and sea-cucumber (Sang, 1963). Figure 17 shows the change in the volume of perivisceral fluid with increasing diameter, where the month of September corresponds to the uncompletion-spawning season, and November is the month of completion-spawning. From the above figure, it is strongly suggested that the volume of perivisceral fluid bears an inverse relationship to the gonad volume, and that the loss in the gross body weight due to the ejection of gametes may be covered with the augmentation of perivisceral fluid.

(d) Variation in weight of the non-gonad tissue with successive growth of the test

About 40 specimens of various sizes were randomly picked up from the aquaria bimonthly. Each specimen was dissected, and then the test, Aristotle's lantern, and gut were separately removed with care so as to avoid any damage.

The gut of the sea urchin is essentially a tube, running from mouth to anus along the inner wall of the test, divided into specialized successive regions termed pharynx, oesophagus, stomach, intestine, and rectum. The basal portion of Aristotle's lantern is attached to the peristomial membrane by connective tissue, and from this region the pharynx runs through Aristotle's lantern. Five edges of the jaw of the lantern are attached to the pharyngeal wall by wedges of connective tissue. Oesophagus connected to the pharynx just above the rotula of Aristotle's lantern. The oesophagus is a complicated curvature coloured light reddish brown, and the descending limbs of the oesophagus are suspended in the coelom by wide mesentery. The end of the oesophagus is connected to the side region adjacent to the tip of the stomach. Viewed from the oral side, the stomach turns in clockwise and the intestine, doubling back upon the stomach, turns counter-clockwise. The intestine is followed by a short rectum which opens to the outside via the anus. The stomach and intestine each have five festoons which will be designated one to five in sequence from the mouth to the anus. They are suspended in the coelom by many mesenteric strands. The descriptions on the food canal of *Strongylocentrotus intermedius* have been already reported by the present author (Fuji, 1961). In the present paper, however, it must be noticed that the test consists of the test proper, the epidermis, the tissues of coelomic lining and the water vascular system attached to it, and that the lantern contains the pharynx.

All measurements of dry weight of these four tissues separated from the sea urchin body were performed on the materials after they had been dried at 100°C for 24 hours.

The regression formulae showing the relation of the dry weight of the test, lantern, and gut to the diameter of the test were calculated bimonthly (Table 14).

Table 14. Regression formulae showing the relation of the dry weight of the test, lantern and gut to the diameter of the test

Date	Test — Diameter relationship	Lantern — Diameter relationship	Gut — Diameter relationship
Feb., 22	log T=2.4178 log D -3.0763	log L=2.0285 log D -3.4530	log G=2.1720 log D -4.2000
Apr., 24	log T=2.7498 log D -3.6459	log L=2.0943 log D -3.5697	log G=1.8992 log D -3.7370
June, 28	log T=2.6066 log D -3.4110	log L=1.9693 log D -3.3825	log G=2.0326 log D -4.1205
Aug., 30	log T=2.4359 log D -3.1354	log L=2.0756 log D -3.5515	log G=2.1470 log D -4.3226
Oct., 26	log T=2.6167 log D -3.4290	log L=1.9843 log D -3.4026	log G=2.2676 log D -4.4755
Dec., 26	log T=2.7189 log D -3.6086	log L=2.1347 log D -3.6561	log G=2.0950 log D -4.0507
Pooled	log T=2.6483 log D -3.4686	log L=2.1212 log D -3.6322	—

Table 15. Analysis of variance of the regression formulae showed in Table 14

a) Diameter—Test relationship

Reduce from	SS	f	V	F ₀ F
Separate line	0.4584	151	0.00303	
Slope diff.	0.0210	5	0.00420	1.39 < 2.27
Parallel lines	0.0297	156	0.00280	
Positional diff.	0.4671	5	0.00592	2.11 < 2.27
Single line	0.4671	161		

b) Diameter—Lantern relationship

Reduce form	SS	f	V	F ₀ F
Separate line	0.3088	151	0.00204	
Slope diff.	0.0192	5	0.00342	1.68 < 2.27
Parallel lines	0.3280	156	0.00216	
Positional diff.	0.0206	5	0.00412	1.91 < 2.27
Single line	0.3486	161		

c) Diameter—Gut relationship

Reduce form	SS	f	V	F ₀ F
Separate line	1.2334	151	0.00816	1.81 < 4.40
Slope diff.	1.0225	5	0.00450	
Parallel lines	1.2559	156	0.00805	
Positional diff.	0.1902	5	0.03804	4.72 > 2.27
Single line	1.4461	161		

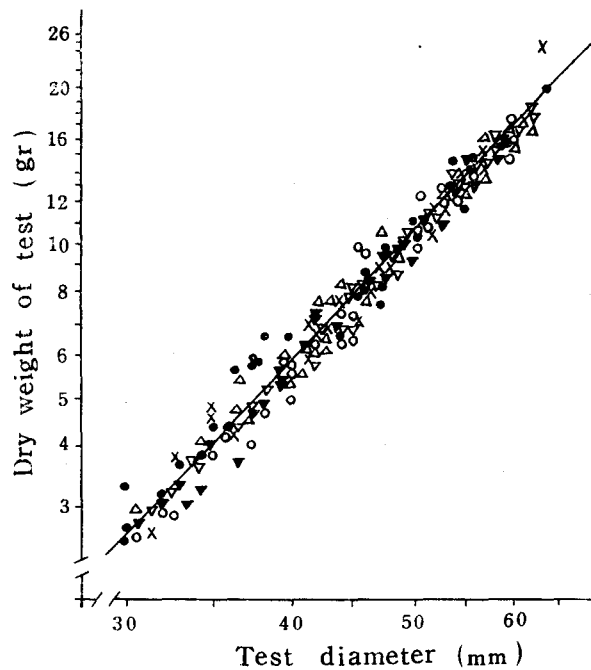
Figure 18. Relationship between diameter and the dry weight of test. Δ : Feb., ∇ : Apr., \circ : June, \times : Aug., \blacktriangledown : Oct., \bullet : Dec.

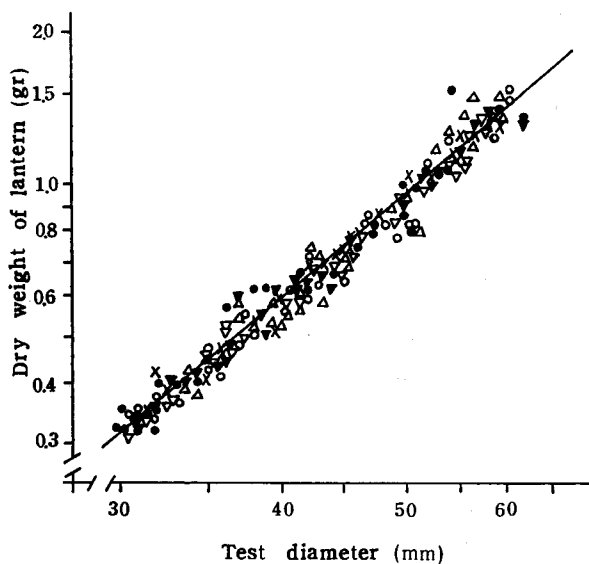

Figure 19. Relationship between diameter and the dry weight of Aristotle's lantern. The symbols are the same as those used in Figure 18.

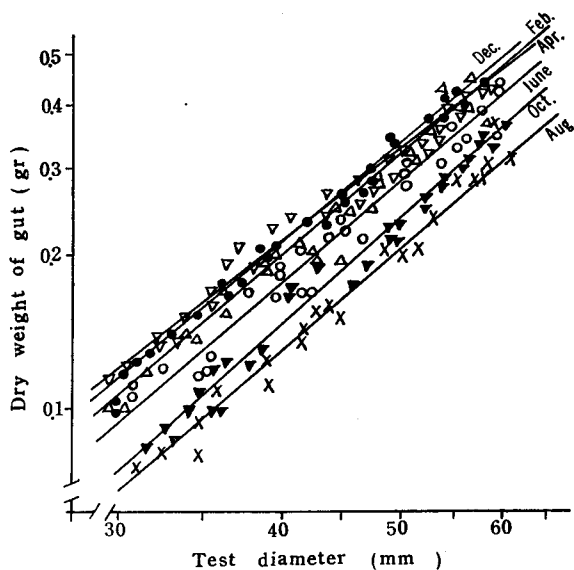

Figure 20. Relationship between diameter and the dry weight of gut. The symbols are the same as those shown in Figure 18.

There was a good correlation between the diameter of the test and each of the body components with the exception of the gonad (viz., test, gut and lantern). The regression formulae for calculating the weight of the test and the weight of the

lantern from the diameter of the test were the same throughout the year (Figures 18 & 19). Analysis of variance of the regression formulae shows an insignificant change in the bimonthly regressions (Table 15). Then, the regression lines calculated from the pooled data were estimated as shown in the bottom row of Table 14. On the other hand, the regression formulae for computing the weight of the gut from the diameter of the test changed significantly with successive months of the year (Figure 20). The weight of the gut would have to be calculated from the regression computed at each time.

IV. Food Habits and Nutrition Absorption

Organisms can gain weight only if they eat more food than is necessary to satisfy their basal metabolism and to provide energy for their activities. Organisms usually a natural food supply sufficient to insure the growth of the body and gonad. Consequently, it may be a reasonable supposition that growth of the body and gonad depend upon what percentage of the food consumed is assimilated and is incorporated into the body.

Information of the food intake of the sea urchin is based on: (1) the food as it appears to be available in the natural habitat, (2) feeding behavior in captivity, and (3) analysis of the gut contents (Dawson, 1868; Scott, 1901; Eichelbaum, 1910; Blegvad, 1914; Jensen, 1915; Mielck, 1922; Van derHeyde, 1922; Wesse, 1925; Hunt, 1925; Parker, 1932; Kawana, 1938 b; Edward & Colvin, 1952; Lasker & Giese, 1954; Stott, 1955; Oshima et al., 1957; Huang & Giese, 1958; Nakamura & Yoshinaga, 1962; Lewis, 1964). Although the above works have reported what foods are consumed by the sea urchin in the natural habitat, the nutritional description which is the important problem from the viewpoint of their metabolism remains unanswered. Studies dealing with the amount of food intake have been published by Oshima et al. (1957), Nakamura & Yoshinaga (1962) and Moore et al. (1963).

Food assimilation by the sea urchin was dealt with by Lasker & Boolootian (1960) and Boolootian & Lasker (1964). However, there are virtually no published investigations on the important problem of how the food is incorporated into the body of the sea urchin. This branch of study seems still to have many questions for further investigation. To determine the average rate of passage of the food mass through the gut may provide some helpful clues to better understanding their feeding, because the rate of passage depends on the size and nature of the food, and the amount of food eaten at one time. To estimate the amounts of food taken in by the sea urchin would be important not only for understanding their feed intake, but also for understanding the organic production.

A study of food intake of the sea urchin would have to include not only the aspect of food ingestion, but also the aspect of incorporation of nutrients in to body through digestion and absorption of the food material taken in. Consequently,

some items of knowledge of the ecological aspects connecting with their food ingestion may be pre-requisite to understand much of the nutrition of this creature.

1. Food habits

(a) Composition and quantity of the gut contents

Field studies of food consumption by the sea urchin were limited to a description of the kinds and quantities of food found in the gut. For this, sea urchins collected from various localities in southern Hokkaido (viz., Muroran, Ishiya and Mori) were used. After weighing each sea urchin, the gut was removed and dissected. Then the contents of the gut were weighed by wet weight.

Figure 21 shows the results of the analysis of the gut contents of the sea urchins collected from Ishiya in July. In this figure, the hyperbolic relation which exists between the body weight and the relative gut contents is shown as a linear correlation between the reciprocal value for body weight and the relative gut contents. Where, relative gut contents are expressed as a ratio of gut

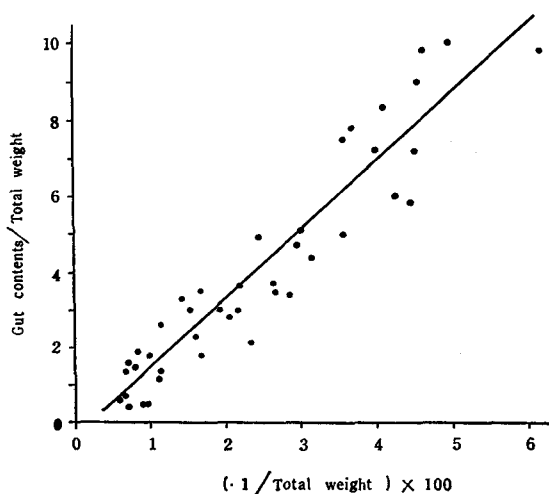

Figure 21. Relation between relative gut contents and total body weight

contents to total body weight. From the above figure, it can be seen that the relative gut contents decrease with increasing body weight. As shown in Figure 22, the relative gut contents of the sea urchins between 40 mm and 45 mm in diameter decreased considerably during the summer. This indicates that the amount eaten decreased in the summer.

The composition of the gut contents is categorized according to the types of food ingested by the sea urchin; (1) algal pellets (green, red, and brown algae), (2) food pellets including diatoms and unidentifiable organic particles, (3) decomposing small animals such as gammarus, isopods, small shells and so forth, and (4) non-food

such as sand and shell fragments. In the present report, these types are referred to as *algal pellets*, *detritus*, *small animals* and *non-food* respectively. The composition of the gut contents of *Strongylocentrotus intermedius* collected from Ishiya in July are shown in Figure 23. This figure illustrates the ratio of the wet weight of each food item, such as algal pellets, detritus or small animals, to the wet weight of the remainder not including the non-food matter. It is clear that the ratio of algal pellets is less than 30 per cent in the specimens under 8 mm in diameter. The ratio increases with increasing size. This strongly suggests that detritus is the predominant food of larval sea urchin and that it is replaced by sea-weeds in animals of about 10 mm in diameter.

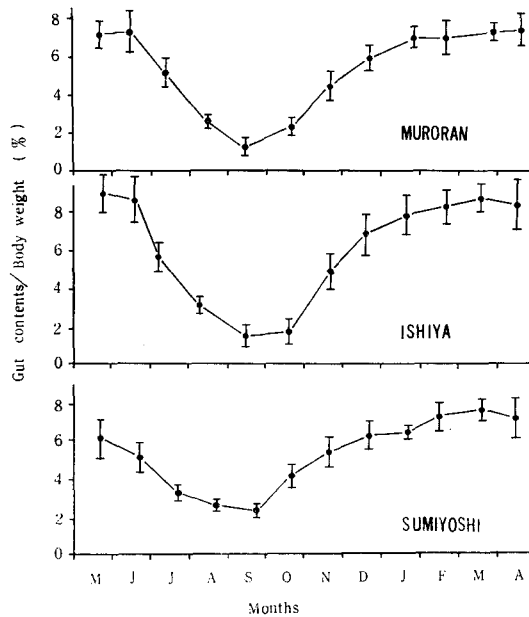

Figure 22. Seasonal variation of relative gut contents

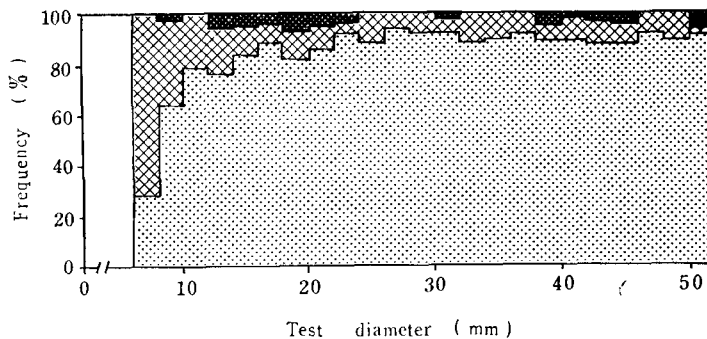

Figure 23. Diagram showing the composition of gut contents. : Algal pellets, : Detritus, : Small animals, : Non-observation.

(b) Feeding activity

It has been reported by Holmes (1912), Bolin (1926) and Millot (1950) that several species of sea urchin move away from light and seek dark, and that the behaviour of the sea urchin is governed by changes in light intensity. Moreover, it has been reported that the most intensive feeding of *Arbacia punctulata* and *Hemicentrotus pulcherrimus* takes place during the night (Parker, 1932; Kawana, 1938 b). It is not known, however, whether or not such feeding activity is a symptom of the inherent rhythm of their feeding activity, and whether or not this rhythm is a crepuscular type as in the case of the land-crab (Yoshida, 1961) and abalon (Ino, 1943; Sakai, 1962).

We studied the correlation between the amount of food eaten and the duration and intensity of insolation both in the natural environment, and under aquarium conditions. For the observations in the natural environment, the sea urchins were placed in experimental wire cages (70×70×20 cm) set at a depth of 3 meters in Usu Bay. In the laboratory, observations were carried out under both artificial and natural lighting conditions. The artificial light source consisted of six 500-watt reflector lamps suspended above the aquarium. This light source produced five different lighting conditions from 36,000-lux to 100-lux by regulating the distance between the lamps and the aquarium.

Twelve experimental groups of ten to thirteen specimens each were exposed to natural lighting conditions and to alternating light and darkness under simulated day and night conditions. Records were made of the feeding behaviour of the sea urchins at 30-minute intervals over two periods of 24 hours. It is possible to recognize when ingestion takes place either by the activation of the tube feet

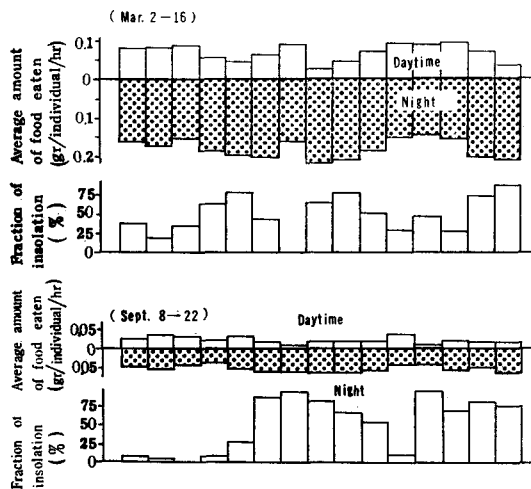

Figure 24. Histogrammatic illustration of the inverse relation between the fraction of insolation and average amount of food (*Laminaria japonica*) eaten

holding and presenting such food as sea-weeds to the mouth or by the motion of the teeth scrapping food from the surface immediately below them. The feeding activity was measured by counting the individuals involved in said behaviour at any one time.

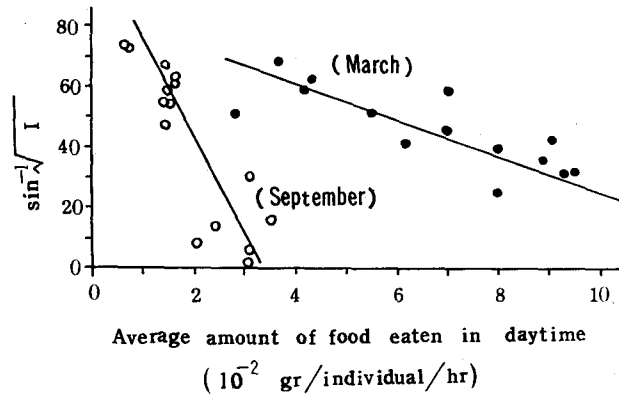

Figure 25. Relationship between the value of fraction of insolation and average amount of food eaten hourly in the daytime

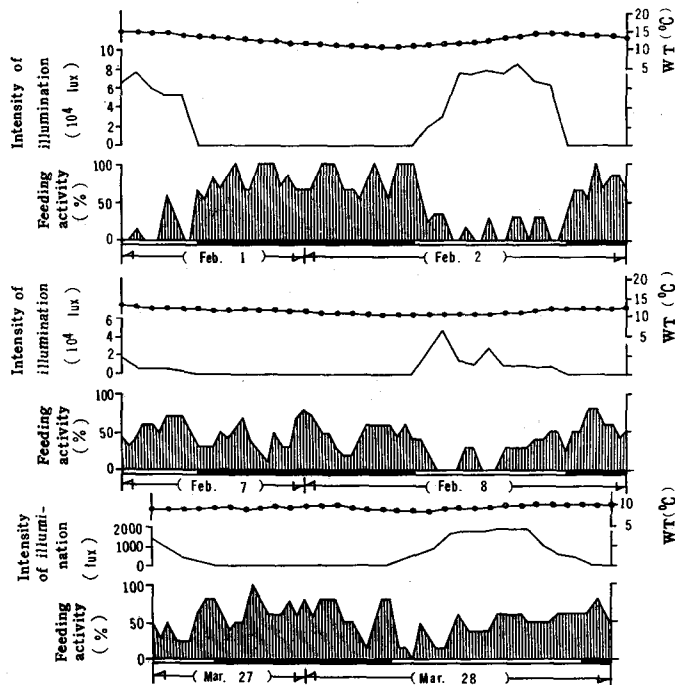

Figure 26. Diurnal feeding activity of *Strongylocentrotus intermedius* with the diurnal variation of the intensity of illumination (early spring). Shaded area in the bottom of each figure shows the night time.

Feeding activity under natural condition: Figure 24 shows an example of the correlation between the amount of food eaten and the intensity of the light under natural conditions. From this figure, it is plain that the average amount of food eaten hourly by an adult sea urchin in the daytime is less than at night, and that such a tendency is more conspicuous on a day with a high fraction of insolation. The correlation between the value of angular transformation ($\sin^{-1}\sqrt{I}$) of fraction of insolation (I) and the average hourly amount of food eaten in the daytime is graphically shown in Figure 25. The regressions in this correlation are highly significant ($F_0 = 17.98 > F(0.05) = 9.09$ in March, $F_0 = 34.64 > F(0.05) = 9.07$ in September). These facts point out that the amount of food eaten hourly in the daytime increases with decreasing light intensity.

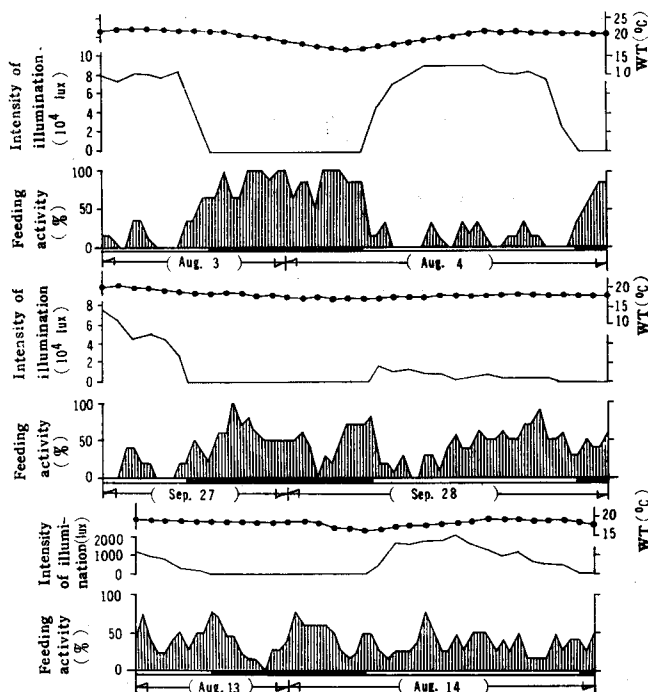

Figure 27. Diurnal feeding activity of *Strongylocentrotus intermedius* with the diurnal variation of the intensity of illumination (summer). The symbols are the same as those used in Figure 26.

The variation of the diurnal feeding activity of the experimental sea urchins under natural conditions is illustrated in Figure 26 together with the diurnal variation of the water temperature and of the intensity of the light. The following conclusions may be drawn from a comparison of the pattern of diurnal feeding with the light intensity. (1) In clear weather, the feeding activity remains at a low level during the daytime, and it is frequently interrupted. After nightfall, the

feeding frequency increases gradually. Although there are some variations the feeding activity continues at a high rate during the night time. (2) In cloudy weather when the light intensity is feeble the feeding activity continues without any interruption during the daytime. (3) Under aquarium conditions when the light intensity was 2,000-lux, the similarities in the feeding patterns of daytime and night time are more striking than the differences. Figure 27 illustrates the diurnal pattern of feeding activity in the summer (August and September). By comparing Figure 26 with Figure 27, it is clear that the feeding activity under various light intensities in early spring (March) follows the same pattern as in the summer. Comparing the daytime and night time feeding activities also reveals that the low rate of activity on days of high light intensity is followed by a high rate of activity at night, while the moderate activity under a low light intensity in the daytime is followed by a similarly moderate degree of activity at night.

From the above mentioned field and laboratory experiments, it is suggested that the feeding activity of *Strongylocentrotus intermedius* in alternating light and darkness under natural conditions is strongly governed by changes of light intensity. This phenomenon may correspond to extrinsic periodicity, and may belong to monophasis as described by Szymanski (1914).

Relation between light intensity and feeding activity: It is impossible from the above observations to know how the intensity of light exerts an oppressive influence on the feeding activity. To understand this point, the experimental animals were exposed to six different light intensities ranging from 36,000-lux to darkness, and the form of the diurnal activity was determined under simulated day and night conditions. The results are summarized in Figure 28. Under the

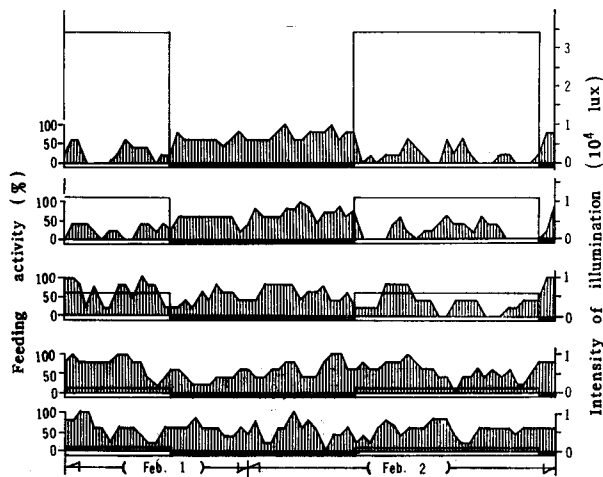

Figure 28. Feeding activity of *Strongylocentrotus intermedius* under various artificial light intensities. The symbols are the same as those used in Figure 26.

illumination of 36,000-lux and 12,000-lux, there was not much feeding activity. This is similar to fine weather. When the light intensity was 6,000-lux, their activities were slightly less than in the dark. When the illumination was 1,000-lux and 100-lux the similarity in the feeding activity between the dark hour and the light hour was more striking than the difference.

For the study to determine the amount of food intake the adult sea urchins were used. They exposed to light, from 6 A.M. to 6 P.M., and darkness, from 6 P.M. to 6 A.M. *Laminaria japonica* was offered as diet. Sea-weeds offered as food for the sea urchins were carefully handled. Most of the water adhering to the surface of the frond was completely removed by absorbent paper. Then the wet weight was determined. Very little fluctuation (under 2%) was found in the wet weight of alga even after immersing in sea water for 5 days (Table 16). Therefore we determined the amount of food ingested by measuring the difference between the wet weight of alga at the beginning and end of the experiments. The results are summarized in Table 17. The amount of food eaten during 12 hours under 36,000-lux is about one-third of the amount of food eaten during 12 hours under darkness. There was a significant difference between the amount of food eaten in

Table 16. Changes in the wet weight of different sea-weeds after immersing in sea water for 5 days. The mean rate of increases (%) is shown in parentheses.

Sea-weed used for observation	Wet weight (gr)		Rate of increase (%)
	Beginning of observation	End of observation	
<i>Laminaria japonica</i>	8.25	8.35	1.21 (1.40)
	4.90	5.00	2.04
	5.25	5.30	0.95
	3.60	3.60	0
<i>Ulva pertusa</i>	4.80	4.75	-1.04 (-0.68)
	3.16	3.15	-0.32
<i>Rhodymenia palmata</i>	11.70	11.80	0.85 (-0.28)
	6.31	6.40	-1.42

Table 17. Average amount of food (*Laminaria japonica*) eaten by the sea urchin in the light and in the dark for each 12 hours

Intensity of illumination (lux)	Amount of food taken (gr) in 12hrs under the condition of		Test of difference F ₀ F	Amount of food taken (gr) in 24 hrs
	Darkness	Lighting		
36000	2.22±0.03	0.70±0.04	1300>5.32	2.92±0.06
13000	1.72±0.05	1.10±0.04	160>5.32	2.82±0.06
6000	1.56±0.04	1.34±0.05	35>5.32	2.90±0.07
1200	1.46±0.03	1.44±0.03	3.0<239	2.90±0.04
460	1.46±0.04	1.46±0.04	5.0<239	2.94±0.03
0	1.48±0.08	1.46±0.03	2.5<239	2.94±0.03

the light and in the dark when the intensity of the light was 6,000-lux or more. The difference was insignificant when the intensity of the light was less than 6,000-lux. The total amount of food ingested in 24 hours (12 hours light, 12 hours dark) was not affected by the intensity of the light.

(c) Amount of food taken in by the sea urchin

A difference between the initial and final wet weight of the sea-weeds every 24 hours indicates the daily amount of food eaten by the sea urchin. The ratio of the daily amount of food ingested against the total body weight of the sea urchins is called the daily rate of feeding in this paper. The daily rate of feeding for each species of sea-weed which was used as food is listed in Table 18, with the range and average value of total weight frequency of each experimental group of animals. There were considerable differences in the daily rate of feeding of various sea-weeds eaten by sea urchins weighing nearly 40 to 65 grams; the maximum rate was about 6 per cent. This occurred when they were supplied with *Laminaria japonica*. The minimum rate was about one per cent. It was for *Ulva pertusa*. It is evident from Table 18 that the daily rate of feeding was between one per cent and 2 per cent for all sea-weeds except *Laminaria japonica* and *Scytosiphon lomentaria*.

Table 18. Daily rate of feeding in the sea urchin reared with each species of sea-weed

Sea-weeds offered to <i>S. intermedius</i>	Month	Test diameter (mm)		Total weight (gr)		Daily amount of food eaten (gr) per individual		Daily rate of feeding (%)
		Range	Average	Range	Average	Range	Average	
<i>Laminaria japonica</i>	Jan.	48.0-54.8	50.4	43.5-61.4	47.4	2.40-3.12	2.71	5.72
Ditto	June	47.6-53.6	50.2	42.8-56.8	49.6	2.78-3.08	2.89	5.81
<i>Alaria crassifolia</i>	June	43.9-55.3	45.7	32.6-65.6	42.6	0.69-1.03	0.97	2.27
<i>Agarum cribrosum</i>	June	43.0-57.7	48.3	32.8-69.4	47.6	0.58-0.79	0.65	1.36
<i>Sargassum tortile</i>	Jan.	45.7-55.6	48.1	41.2-60.0	45.1	0.49-0.68	0.60	1.33
<i>S. Thunbergii</i>	Jan.	49.1-54.8	50.6	48.6-61.0	48.1	0.88-1.23	1.04	2.16
<i>Scytosiphon lomentaria</i>	Jan.	47.0-55.8	51.0	41.4-66.3	50.8	1.78-2.24	1.95	3.84
<i>Ulva pertusa</i>	Jan.	46.6-51.0	48.0	40.3-52.8	46.7	0.39-0.49	0.45	0.96
Ditto	June	43.3-51.8	46.1	33.3-53.0	45.2	0.46-0.72	0.54	1.19
<i>Chondrus ocellatus</i>	Jan.	45.1-55.1	49.3	42.1-63.8	48.9	0.88-1.10	0.96	1.96
Ditto	June	45.4-55.2	50.1	41.5-67.1	51.2	0.89-1.33	1.13	2.21
<i>Packymeniopsis Yendoii</i>	June	46.4-54.1	48.9	40.3-65.0	50.3	0.56-0.82	0.66	1.31
<i>Rhodymenia palmata</i>	Jan.	47.0-55.1	51.2	41.4-63.8	50.8	0.87-1.05	0.93	1.83
<i>Rhodoglossum pulchrum</i>	Jan.	48.9-58.1	52.0	48.2-68.9	50.3	0.66-0.81	0.72	1.43
<i>Phyllospadix iwataensis</i>	June	47.3-54.6	50.0	43.1-68.3	50.1	0.88-1.30	1.02	2.03

A comparison was made of the daily rate of feeding of various size-groups when fed with *Laminaria japonica*. The sea urchins between 25 mm in diameter (6 gr in total body weight) and 70 mm in diameter (122 gr in total body weight) were divided into six groups as a result of the feeding experiments, as shown in Table 19. Although the daily rate of feeding shows slight variation within a group probably

Table 19. Comparison of the daily rate of feeding of various size-groups when fed with *Laminaria japonica*. The observations were performed in February when the water temperature ranged from 6.8°C to 9.3°C.

Group number	Test diameter (mm)	Total weight (gr)	Daily amount of food eaten (gr)	Daily rate of feeding (%)
I	24.6±0.6	6.0±0.8	0.84±0.06	13.96±0.81
II	34.9±0.4	18.7±2.1	1.64±0.11	8.75±0.95
III	41.7±0.7	31.6±4.9	2.41±0.09	7.61±0.30
IV	49.1±0.7	48.3±4.1	2.80±0.16	5.80±0.22
V	60.2±0.6	83.7±5.7	4.53±0.21	5.41±0.35
VI	69.8±0.8	122.4±4.8	5.60±0.14	4.58±0.41

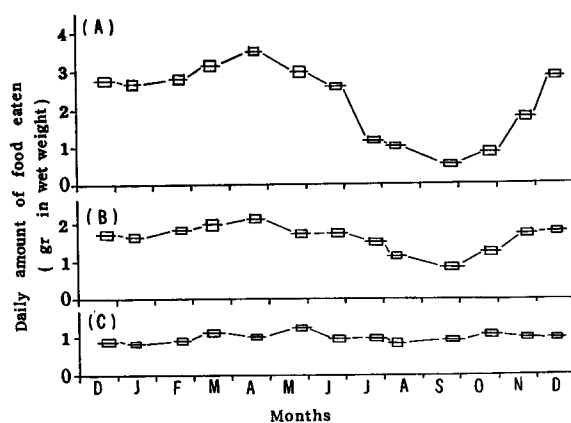

Figure 29. Seasonal variations of the daily amount of food (*Laminaria japonica*) eaten by adult and young sea urchins. In each column the width of square marks indicates the duration (in day) of the experiments while the height shows the range of plus or minus in standard error of mean and horizontal lines indicate the mean value. (A) and (B): Data obtained from two groups of adult sea urchins (ca. 55 mm and 40 mm in average diameter), (C): Data obtained from one group of young sea urchins (ca. 20 mm in diameter).

due to the physiological conditions of the specimen, it is obvious that this rate decreases as the sea urchin grows larger.

Figure 29 shows graphically how the amount of food (*Laminaria japonica*) eaten daily by two groups of adult sea urchin (ca. 55 mm and 40 mm in diameter) and by one group of young ones (ca. 20 mm in diameter) fluctuates in the different seasons of the year. From the above figure, it is plain that the eating pattern of the adults differs from that of the young, especially from July to October. The amount of food eaten daily by an adult sea urchin in July is significantly lower than in June. And the average for September (ca. 0.5 gr) is the lowest for the year. After September, the amount of food eaten daily increases steadily till it reaches approximately 3 gr in December. On the other hand, the seasonal pattern of the daily

amount of food ingested by young urchins shows no marked fluctuation throughout the year, although a slight diminution of the value is noted in August. Consequently, it may be said that a marked seasonal fluctuation of the amount of food eaten daily is found in the adult sea urchin alone.

Some items of information regarding the effect of the temperature upon the amount of food eaten have been already reported by the present author (Fuji, 1962). As reported, in March during the season of sluggish development of the gonad, the sea urchins are steadily (3.2-3.5 gr in wet weight per day per individual) when the temperature ranged between 5° and 15°C; but at higher temperatures the feeding rate declined, becoming approximately 1.6 gr per individual when the water temperature was 23°C. The data obtained from the feeding experiments performed in September, corresponding to the pre-spawning season, showed a markedly lower rate of eating than in March. In the previous chapter with the development of the gonad, it was clearly shown that the months from July to September belong to the pre- and incompletion-spawning period. From the above information, it can be said that the decline in the feeding rate of adult sea urchins from July to October, their breeding season, may be caused by some internal physiological factors connected with gonad growth. In other echinodermata, *Asterias forbesii* and *A. rubens*, as Galtsoff & Loosanoff (1939) and Hancock (1955, 1958) have reported, a similar decline in eating takes place with the approach of the breeding season. In general, the seasonal pattern of the amount of food eaten may be summarized as follows. During the pre- and incompletion-spawning period, from July to September, the adult sea urchins fed only rarely, but after completion of spawning they become excessively voracious throughout the winter.

2. Nutrition absorption

Growth is based on the amount of food assimilated which is assessed by studying the digestion and absorption of food eaten. Food material is propelled along the gut at a rate which permits effective digestion and absorption of the utilizable constituents of the food. This section describes the profile of digestion, which may be presumed from a study of the movement of the food mass through the gut and from the assessment of the amount of food assimilation.

(a) Transport of food mass through the gut with digestive and feeding processes

In this experiment five to eight specimens of sea urchin were picked up at random at definite time intervals and the total body weight and the total wet weight of the gut contents were measured. The experiments covered a period of 10 days. Observations of the feeding process of this animals were initiated by giving alga as food after starvation of 10 days, that being the experimental period of the digestive process. The amount of food found in the gut was converted into the weight of gut contents per total body weight as this is a most convenient value to

show the relative contents.

Maximum gut contents: Before preceeding the values for maximum gut contents must be explained because they are used as standards. Table 20 shows the gut contents of sea urchin fed with a single algal species for 2 months. The gut contents amount to about 4.9 per cent of the total body weight when the sea urchin has been supplied with only *Scytosiphon lomentaria*, and about 3.1 per cent for *Ulva pertusa*. These figures indicate the maximum gut contents, because almost all guts examined were packed with food mass.

Table 20. Average gut contents of sea urchin fed with a single algal species for two months

Sea-weeds offered to sea urchin	Total weight of sea urchin (gr)	Gut contents (gr)	Relative gut contents (%)
<i>Laminaria japonica</i>	47.8	2.18	4.56
<i>Sargassum tortile</i>	50.2	2.03	4.04
<i>S. Thunbergii</i>	46.6	2.23	4.78
<i>Scytosiphon lomentaria</i>	47.3	2.30	4.86
<i>Ulva pertusa</i>	49.8	1.55	3.11
<i>Chondrus ocellatus</i>	51.6	2.02	3.91
<i>Rhodymenia palmata</i>	50.6	1.96	3.87
<i>Rhodoglossum pulchrum</i>	49.1	1.69	3.45

The term maximum gut contents is a little misleading, since, as a matter of fact, a sea urchin may have more in its gut than what is here called maximum. Under the prevailing ecological conditions, however, it is very rare that a sea urchin has more in its gut than this quantity of food.

Digestive process: Experiments were performed on two groups of sea urchin; the first one was given *Laminaria japonica* as food material and the other was fed with *Ulva pertusa*. From Figure 30 it can be seen that the food passed through the gut more quickly in July than April or December. For instance in the case of the sea urchins fed with *Laminaria japonica* in April and December the food mass in the gut still amounted to one per cent of the body weight after 3 days of no food. This is equal to about a quarter of the maximum gut contents. After 3 days the gut contents remained at a constant level with very slight decrease. On the other hand, in July the food mass in the decreased to 0.5 per cent of the body weight in only 2 days and remained constant.

The decrease in the amount of gut contents in the group of the sea urchin which lived on *Ulva pertusa* was slightly slower. And the time taken to reach a constant level was longer. This may be attributed to the difference in the nutrient substances of the algae, since the retention time of food in the gut is inversely related to the efficiency of the digestive processes. No faecal pellets were ejected during the 10 days of no food, although a very small quantity of defecation (less

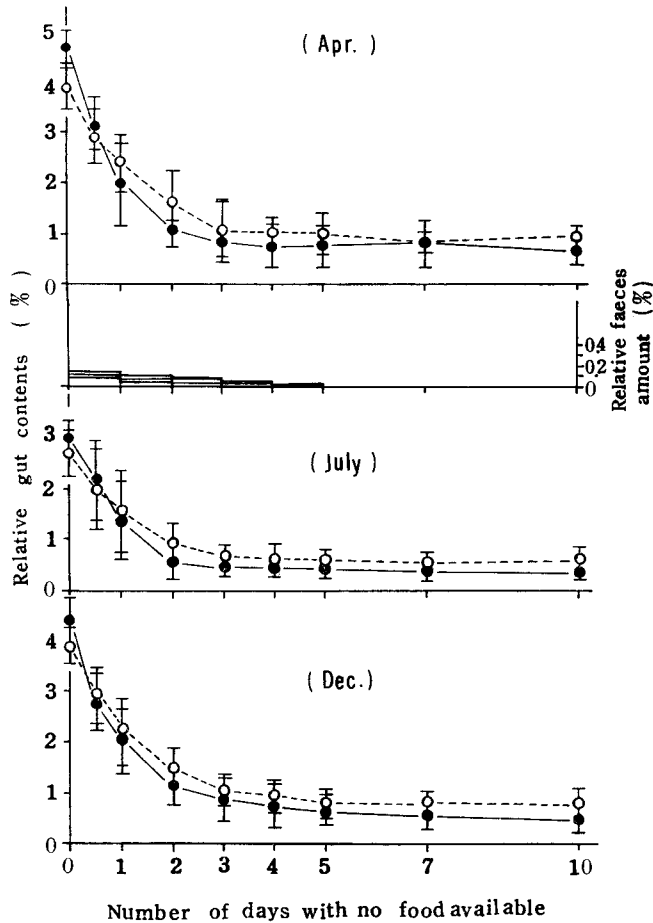

Figure 30. Decrease in the amount of gut contents in the group of the sea urchin under starvation. The gut contents are represented as the percentage of total body weight. Vertical lines indicate the standard error of the mean. The symbols are indicated as follow; ○: Data on the group supplied with *Ulva pertusa*, ●: Data on the group fed with *Laminaria japonica*.

than 0.2%) was produced during the first few days (see the right side of Figure 30). Therefore, it is strongly suggested that the decreases in the gut contents when no food was given are attributable to digestion and absorption rather than elimination.

The stomach and the intestine which was removed without any damage was trisected crosswise, and the food mass from each of the six parts was weighed in wet weight. The results are histogramatically shown as percentages of body weight in Figure 31. The time of retention of food mass in the stomach region is limited to one day in both groups of sea urchin. After one day the food mass in the stomach is transported towards the intestine. It can be clearly seen from

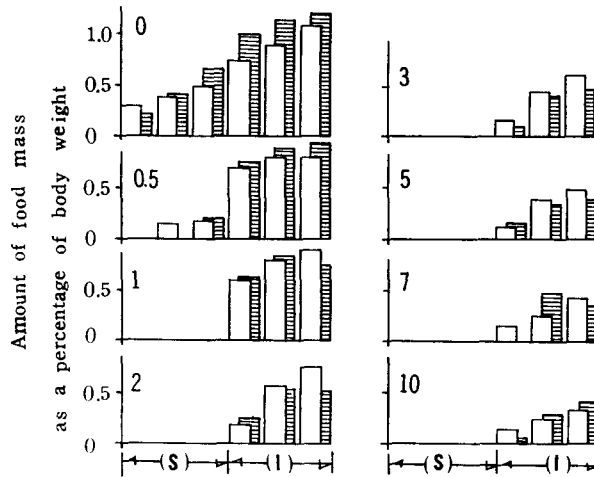

Figure 31. Histograms showing changes of the food mass found in the six parts of the gut when no food was offered. The figures are the mean value of six specimens. The starvation period (in day) is given as Arabic number in the left side of each figure. "S" indicates the regions of stomach part and "I" indicates the regions of intestinal part. In each column the shaded area is the datum obtained from the sea urchin groups fed with *Ulva pertusa* and the blank area is the datum from the groups fed with *Laminaria japonica*.

Figure 31 that the food mass is gradually propelled toward the end of the intestine with progressive digestion.

Feeding process: Two groups of sea urchin, one supplied with *Laminaria japonica* and one supplied with *Ulva pertusa* after a period of starvation were observed. The changes in the volume of the gut contents with successive feeding are illustrated in Figure 32. In all experiments, the gut contents of the sea urchins fed *Laminaria japonica* attained a high level within shorter period than did the sea urchins fed *Ulva pertusa*. In the first group, faecal pellets were ejected within one day, although they were very small amounts (about 0.1% of the body weight). After this period, nearly constant amounts of faeces were produced. On the other hand, as may be seen in Figure 32 the excretion of green faecal pellets, of the group fed *Ulva pertusa*, did not begin until 3 days after the beginning of feeding.

Respective amounts of the food mass found in the trisected parts of the stomach and the intestine are histogrammatically illustrated in Figure 33 as percentages of body weight. The first day after feeding began the first part of the stomach contained most of the food mass and the end of the gut contained the smallest part of the food mass. As has already been shown in Figure 31, under normal feeding conditions the food mass in the stomach was quite a bit less in quantity than that in the intestinal region. We estimate that the average rate of passage for *Laminaria japonica* is about one day, and the co-ordinate value for *Ulva pertusa* is 2 or 3 days.

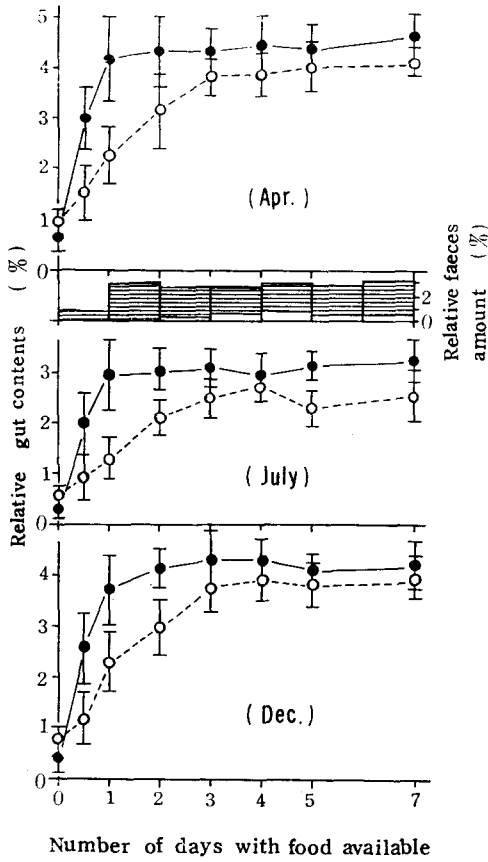
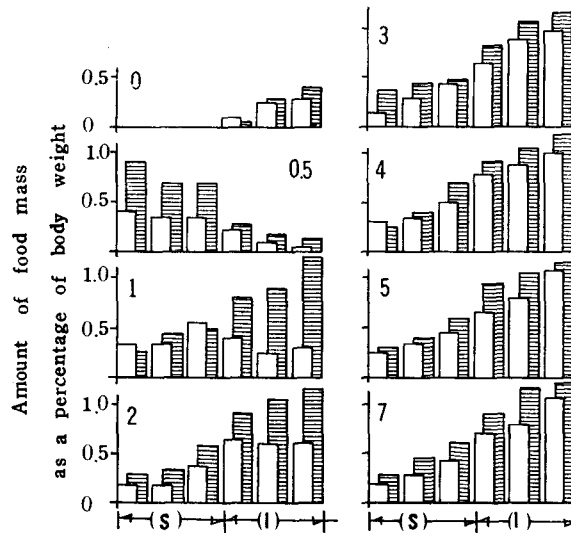

Figure 32. Changes in the volume of the gut contents with successive feeding. Symbols are the same as those used in Figure 30.

Figure 33. Histogram showing the changes of the the food mass found in the six parts of the gut at the time of feeding. The figures are the mean value of six specimens. The feeding period (in day) is given as Arabic numeral in the left side of each figure. The symbols are the same as those in Figure 31.



(b) Food assimilation

The following experiments were made on sea urchin to determine the amounts of food assimilated and of nitrogen absorbed. The amounts were calculated as follows:

$$\text{Assimilation efficiency in \%} = \frac{\text{Dry weight of food assimilated}}{\text{Dry weight of food eaten}} \times 100$$

where, Dry weight of food assimilated = Dry weight of food eaten
 - Dry weight of faeces

$$\text{Absorption efficiency of Nitrogen in \%} = \frac{\text{Nitrogen in food assimilated}}{\text{Nitrogen in food eaten}} \times 100$$

After removing the water adhering to the frond surface, bits of the frond were cut at random from the sea-weeds used as food for the sea urchin, and were placed in a drying oven at 90°C. The dry substances were minced in a meat grinder, and were stored in a desiccator for chemical analysis. Faeces, which settled on the bottom of the aquarium during the experiment, were siphoned out together with aquaria water every day, and filtered under suction through a filter paper whose dry weight had been measured. The weight of the faeces was estimated as the difference between the dry weight of the faeces with the filter paper and that of the filter paper alone. As much material as possible was removed from the filter paper by scrapping the paper lightly with a knife. This material was used for chemical analysis. The total nitrogen of the sea-weeds and of the faeces was analysed by means of micro-Kjeldahl.

The nitrogen considered to be the ejection of true protein can come from several sources; (1) undigested protein, (2) possible parasitic and symbiotic inhabitants of the gut which are eliminated, and (3) food canal tissue breakdown. The protein of the faeces composed of the last two items is not known, so they have been lumped together with undigested protein. In a preliminary experiment, the nitrogen content in the faeces excreted by the sea urchins fed agar-agar as a non-nitrogen diet was less than 0.05 per cent. This error is not considered to be large enough to influence the main conclusions.

As was shown in Figure 17 in *Strongylocentrotus intermedius*, the volume of perivisceral fluid bears an inverse relation to the gonad development, being present in larger amounts when the gonad is less developed. A similar phenomenon has been observed in other sea urchins, *Strongylocentrotus purpuratus* and *St. franciscanus*, and in starfish, *Asterias rubens* (Lasker & Giese, 1954; Farmanfarmanian et al., 1958; Greenfield et al., 1959). In studies published on *Strongylocentrotus purpuratus* and *St. franciscanus*, (Lasker & Giese, 1954; Bennett & Giese, 1955) it has been shown that the perivisceral fluid contains small amounts of protein, reducing sugar, lipid and non-protein nitrogen, and that these organic elements do not vary in any striking or systematic way throughout the

year. Consequently, it is conjectured that the amount of nutriment in the perivisceral fluid varies according to the volume of perivisceral fluid. Since the perivisceral fluid is an avenue for the transportation of nutriment from reserves to other tissues (Farmanfarmanian & Phillips, 1962), it is not a significant place for the storage of nutriment. From this viewpoint, the perivisceral fluid was omitted from the present observation concerning the nutrition of the sea urchin, *Strongylocentrotus intermedius*.

Assimilation efficiency of food eaten and absorption efficiency of nitrogen: The results are summarized in Table 21. The assimilation efficiency of *Scytosiphon lomentaria* was the highest (83%) and that of *Laminaria japonica* and *Condrus ocellatus* was the lowest (57%). The absorption efficiency of nitrogen varied from 63 per cent to 95 per cent according to the kind of algae offered to the sea urchin. The assimilation efficiency of surf-grass, *Phyllospadix iwatensis*, was only about 32 per cent, the remainder was ejected as faeces. However, the absorption efficiency of nitrogen from the surf-grass was the same as from algae (ca. 67%).

A study on the assimilation of alga by the sea urchin, *Strongylocentrotus purpuratus*, was reported by Lasker & Boolootian (1960). They indicated that more than 76 per cent of the alga, *Macrocystis pyrifera*, was absorbed during the digestive process of the sea urchin. In their work, using an urchin which had been starved until no faecal pellets were ejected, the amount of food absorbed was estimated by subtracting the dry weight of the undigested residue in the gut from the dry weight of the alga eaten. Despite the difference in the manner of the two observations, the assessment of the efficiency of food assimilation obtained from *Strongylocentrotus intermedius* (Table 21) is in amazingly close agreement with that from the purple sea urchin, *Strongylocentrotus purpuratus*, as reported by Lasker & Boolootian (1960).

Columns 11 and 12 of Table 21 show the average amounts of food assimilated daily and of nitrogen absorbed daily from the various algal species. The amounts of food assimilated vary widely from 70 mg per day to 280 mg per day according to the kind of algae. The amounts of nitrogen absorbed fell between 2 mg per day and 5 mg per day except for 7.5 mg per day when *Scytosiphon lomentaria* was supplied. The above information, however, can not explain what effects the efficiency of food conversion. The problem of how the organic product, especially body growth and gonad growth, is affected by differences in amounts and quality of food must be considered to provide a more complete understanding of the feeding ecology of the sea urchin.

The amount of food assimilated was measured for six different size-groups of ten specimens each, with *Laminaria japonica* given as food, and the water temperature between 6.8° and 9.8°C. Table 22 shows the amounts of food assimilated, expressed as percentages of the weights of food eaten. The significance of the discrepancies in the amount of food assimilated among the respective groups

Table 21. Daily amount of food assimilated and of nitrogen absorbed by individual adult sea urchin when different sea-weeds were used as food. Each figure indicates the mean value from five to eight experiments.

Sea-weeds offered to <i>S. intermedius</i>	Month of exp.	Food eaten					Faeces excreted			Daily amount of food assimilated (mg)	Daily amount of nitrogen absorbed (mg)	Assimilation efficiency of food (%)	Absorption efficiency of nitrogen (%)
		Amount in wet weight (gr)	Water content (%)	Amount in dry weight (mg)	Nitrogen content (%)	Nitrogen content (mg)	Amount in dry weight (mg)	Nitrogen content (%)	Nitrogen content (mg)				
<i>Laminaria japonica</i>	Jan.	2.71	90.46	258.5	1.40	3.62	111.8	1.15	1.28	146.7	2.34	56.7	64.6
Ditto	June	2.89	85.48	419.6	1.54	6.46	142.6	1.26	1.80	277.0	4.66	66.0	72.1
<i>Alaria crassifolia</i>	June	0.97	77.81	214.3	1.91	4.09	65.5	1.86	1.22	148.8	2.87	69.4	70.2
<i>Agarum cribrosum</i>	June	0.65	77.61	145.5	1.97	2.87	39.9	1.90	0.76	105.6	2.11	72.6	73.5
<i>Sargassum tortile</i>	Jan.	0.60	80.36	117.8	2.16	2.54	43.7	2.16	0.94	74.1	1.60	62.8	63.0
<i>S. Thumbergii</i>	Jan.	1.04	81.38	193.6	2.20	4.26	79.9	1.62	1.29	113.7	2.97	58.7	69.7
<i>Scytosiphon lomentaria</i>	Jan.	1.95	86.15	270.1	3.20	8.64	44.9	2.41	1.08	225.5	7.56	83.4	87.5
<i>Ulva pertusa</i>	Jan.	0.45	74.41	115.2	5.36	6.17	29.5	2.76	0.81	85.7	5.36	74.4	86.8
Ditto	June	0.54	77.89	119.8	3.41	4.08	21.6	2.21	0.48	98.2	3.60	81.9	88.2
<i>Chondrus ocellatus</i>	Jan.	0.96	79.01	201.6	2.81	5.66	87.1	1.95	1.70	114.5	3.96	56.8	69.9
Ditto	June	1.13	79.68	229.8	3.11	7.15	88.4	1.95	1.72	141.4	5.43	61.5	75.9
<i>Packymeniopsis Yendoi</i>	June	0.66	80.28	130.1	1.82	2.37	41.2	0.94	0.39	89.9	1.98	68.3	83.5
<i>Rhodomenia palmata</i>	Jan.	0.93	90.20	91.1	3.64	3.32	23.3	3.02	0.70	67.8	2.62	74.4	78.9
<i>Rhodoglossum pulchrum</i>	Jan.	0.72	82.13	128.7	4.45	5.73	30.4	0.93	0.28	98.3	5.45	76.3	95.1
<i>Phyllospadix iwataensis</i>	June	1.02	86.71	135.6	2.05	2.78	91.6	0.99	0.91	44.0	1.87	32.4	67.2

Table 22. Amount of food (*Laminaria japonica*) assimilated in 24 hours by different size-groups of the sea urchin. All weights are represented by dry weights. Each figure is the mean value from ten experiments, the range is given in parentheses.

Size-group	Test diameter (mm)	Amount of food eaten (mg)	Amount of faeces excreted (mg)	Amount of food assimilated (mg)	Assimilation efficiency (%)
I	24.6 (20.2-26.4)	80.1 (76.3-85.9)	32.0 (28.3-36.5)	48.1 (45.5-49.4)	60.1 (59.7-62.9)
II	34.9 (29.8-38.8)	156.4 (143.1-169.8)	61.3 (45.1-71.8)	95.1 (74.2-110.8)	60.8 (51.9-69.9)
III	41.7 (38.9-44.3)	229.9 (217.5-238.5)	42.5 (73.5-92.6)	147.4 (137.6-158.3)	64.1 (60.1-68.3)
IV	49.1 (46.8-52.0)	267.1 (254.5-273.8)	110.4 (103.1-122.6)	156.7 (150.1-170.7)	58.7 (55.2-62.3)
V	60.2 (55.0-65.1)	432.2 (405.4-453.1)	183.1 (151.6-190.1)	249.1 (258.1-310.1)	57.6 (56.4-60.2)
VI	69.8 (65.3-72.1)	534.3 (515.2-553.3)	226.0 (200.9-243.8)	308.2 (272.4-333.4)	57.7 (52.8-62.4)

was tested by means of analysis of variance. No significant difference ($F_0=3.54 < F(0.05)=9.55$) was found in the assimilation efficiencies of the six different size-groups used in the present experiment. In other words, the observations indicate that the ability to assimilate food is essentially alike in adult and young urchins. The percentage of food assimilated was between 50 per cent and 70 per cent, with an average value of about 60 per cent.

Seasonal variation of the amount of food assimilated: Feeding experiments were made on adult sea urchins, with *Laminaria japonica* used as food, to determine seasonal variation in the amount of food assimilated. Average assimilation

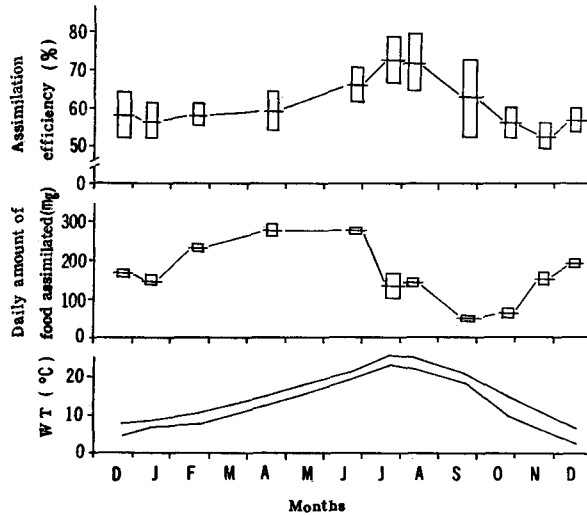

Figure 34. Diagram showing the seasonal variations of the amount of food (*Laminaria japonica*) assimilated by the adult sea urchins. In the first two figures the symbols are the same as those used in Figure 29. The two curves in the last figure represent the maximum and minimum temperature respectively.

efficiency in each month increased with rising water temperature and vice versa. From December to June, the average value increased slowly as shown in Figure 34, although it remained between 55 per cent and 60 per cent. In July and August the value increased to about 73 per cent, followed by about 63 per cent in September. Then the average value of the assimilation efficiency decreased with the fall in temperature, until it came to a low in December.

Knowing the changes which occur in the amount of food assimilated throughout the entire year is also important in studying nutrition absorption. A compendium of these facts is graphically shown in Figure 34. The value increases markedly in February, attaining about 230 mg per day per individual. From this month to June, it keeps nearly a constant level of approximately 270 mg per day. The value commences a gradual decrease in July, and reaches its lowest point (ca. 50 mg/day) in September. In November the daily amount rises, and the sea urchins used in this month assimilated about 170 mg of *Laminaria japonica* per day per individual.

V. Rate of Production and Protein Metabolism

The rate of biological production of any organism is dependent upon an adequate food supply, and therefore can be said to be an account of energy flow through metabolic processes. Thus, it is desirable to study how efficiently animals are able to utilize food for growth in order to measure their organic productivity.

Sea urchins usually have a natural food supply sufficient to insure growth. Some information concerning the ecological aspects of food intake were dealt with the former chapter. However, the question of how the organic production is affected by differences in the amount and quality of food eaten remains unanswered.

In general, the body of the sea urchin consists of two main parts in which organic production occurs in different forms; one part is the gonadal tissue, and the other part consists of the test, Aristotle's lantern and gut. As shown in the previous chapter, the gonadal tissue of a gravid urchin may have an index value of as much as 25, while the gonad of an immature animal or of a spent animal only has an index value of 6. Since the larger part of the protoplasm of a sea urchin is contained in the gonadal tissue, the development of the gonad represents a remarkable synthesis of organic materials. Thus, the growth and depletion of the gonad corresponds to a great production and expenditure of organic products. The growth of the gut, lantern and test, on the other hand, continues steadily if the supply of food is sufficient. Consequently, the profile of organic production of the sea urchin may be understood by studying the relation between the amount of food assimilated and the amount of organic products in each tissue in which organic production may occur. Metabolism of body material may be determined

by studying the incorporation of organic products into various tissues of the body during growth.

In this chapter, an attempt was made to measure the amount of food converted in tissues of the sea urchin's body and to measure the amount of food required to maintain normal life. These measurements were made to understand the incorporation of nutrients into body material through digestion, absorption and assimilation of the food ingested by the sea urchin, *Strongylocentrotus intermedius*.

1. Food conversion

Growth during the period of investigation could be based only by knowing the size of the organs of the experimental urchins at the beginning of the experiment. Consequently, at the beginning of the experiment sample urchins were selected to represent each group of the experimental urchins. The sample urchins were approximately the same size as the experimental urchins. They were collected at the same time and were treated in exactly the same way as the experimental urchins until the moment when the latter were introduced into aquaria.

A number of other sea urchins representing the various size-groups were separated from the experimental urchins and the diameter was measured periodically. They were treated the same way as the other experimental urchins during the entire course of the experiment.

From the regression formulae shown in Table 14, it is possible, without killing an animal, to make an accurate estimate of the dry weight of non-gonad tissue (viz. test, lantern and gut) from the average diameter of the sample urchins. A difference between the initial and the final weight of each tissue during the experimental period indicates the amount of absolute growth in each tissue. The amount of growth of the gonad was estimated as the difference between the average weight of the gonad of experimental urchins at the beginning and at the end of the experiment. The total absolute growth in dry weight is the sum of the increased amount in each tissue.

Moisture of the alga offered to the sea urchin as food was measured by drying small pieces of frond cut from the same alga. The amount of food ingested was the difference between the wet weight of the alga before and after the feeding experiment. The dry weight of the amount ingested was easily computed from the wet weight of the food ingested. Then, the growth efficiency for each size-group of the sample urchins was calculated as follows:

$$\text{Growth efficiency in \%} = \frac{\text{Dry weight of absolute growth}}{\text{Dry weight of food assimilated}} \times 100$$

where, Dry weight of food assimilated = Dry weight of food eaten
 - Dry weight of faeces ejected

(a) Growth efficiency

The growth efficiencies of sea urchins eating different kinds of sea-weed are compared in Table 23, along with the amounts of average absolute growth of the experimental sea urchins from February to April. The growth efficiency (Table 23) varies considerably according to the kind of sea-weeds. The maximum growth efficiency was 28.6 per cent which was obtained when the sea urchin were supplied with *Alaria crassifolia*. The minimum value was about 5 per cent with *Agarum cribrosum*.

Table 23. Growth efficiency of sea urchins eating different kinds of sea-weed. Each figure indicates the mean value from five to eight experiments.

Sea-weeds offered to <i>S. intermedius</i>	Duration of rearing (day)	Test diameter (mm)		Food assimilated (mg/day)	Amount of growth (mg/day)					Growth efficiency (%)
		Beginning of exp.	End of exp.		Test	Lantern	Gut	Gonad	Total	
<i>Laminaria japonica</i>	60	46.83	47.83	134.3	8.6	0.6	0.3	10.4	19.9	14.81
<i>Alaria crassifolia</i>	50	50.17	51.94	138.6	21.0	2.4	0.4	15.9	39.7	28.64
<i>Agarum cribrosum</i>	50	51.96	52.14	69.6	2.2	0.7	0	0.2	3.1	4.45
<i>Sargassum tortile</i>	60	50.41	51.02	77.5	6.0	0.4	0.2	6.5	13.1	16.91
<i>Scytosiphon lomentaria</i>	50	49.86	51.08	204.6	14.2	1.0	0.3	23.1	38.6	18.87
<i>Packymeniopsis Yendoi</i>	50	51.36	51.40	53.6	0.4	0	0	6.5	6.9	9.91
<i>Rhodymenia palmata</i>	50	50.20	50.98	72.1	9.2	0.6	2.2	6.7	18.7	25.94
<i>Ulva pertusa</i>	50	51.30	52.26	65.5	11.6	0.4	0.2	5.9	18.1	27.63

Table 24. Growth efficiency of various size-groups of sea urchins fed with *Laminaria japonica*. Each figure represents the mean value from five to eight experiments.

No. of group	Duration of rearing (day)	Test diameter (mm)		Food assimilated (mg/day)	Amount of growth (mg/day)					Growth efficiency (%)
		Beginning of exp.	End of Exp.		Test	Lantern	Gut	Gonad	Total	
I	150	18.55	31.80	47.90	16.04	1.63	0.33	6.14	24.51	51.17
II	150	28.70	38.56	84.45	19.60	1.67	0.23	11.80	33.30	39.43
III	120	38.74	41.24	113.15	9.41	0.65	-0.26	14.83	24.64	21.78
IV	120	46.83	48.26	134.31	6.25	0.44	-0.56	17.48	23.61	17.56
V	120	54.77	55.34	161.43	3.08	0.20	-0.94	21.05	23.40	14.50

During this experiment the food was always supplied in plentiful amounts, so the food ingestion of the sea urchin was never limited by a shortage of food. The maximum amount of weight increase was about 40 mg per day when *Scytosiphon lomentaria* and *Alaria crassifolia* were supplied, and the minimum was about 3 mg per day when *Agarum cribrosum* was supplied.

A comparison was made of the growth efficiency of various size-groups of sea urchins fed with *Laminaria japonica*. From Table 24, it is understood that the efficiency decreases as the urchin grows larger. This finding suggests that the metabolic rate decreases with the increasing size of the sea urchin, and that this phenomenon is probably associated with ageing.

(b) Annual energy budget

In this section the problem is to clarify the energy exchanges of the sea urchin with a view to drawing up an energy balance-sheet. Food enters the food canal, where it is digested. Much nutritive material is absorbed through the wall of the gut (absorbed, or digestible energy), the remainder, plus any undigested remains, being defecated (faeces energy). Absorbed energy can be used for internal and external work, maintenance, and the growth. Ultimately, this energy, less that proportion of it which is stored within the organism, is lost as heat. It has been well established that in any biological closed system the total energy input is equal to the total energy output. In summary, therefore, the transformation of energy within the sea urchin body (as an individual) may be represented by the following equation:

$$\begin{aligned} \text{Energy input} &= \text{Energy wasted in faeces} + \text{Energy lost as heat} + \text{Energy stored} \\ \text{where, Energy lost as heat} &= \text{Energy used for maintenance} \\ &\quad + \text{Energy used for internal and external work} \\ \text{and Energy stored} &= \text{Energy used for body growth} \\ &\quad + \text{Energy used for gonad growth} \end{aligned}$$

To know the amount of energy consumed by the sea urchin and to determine how much of this energy goes into body growth and gonad growth, and how much is lost as heat during the animal's daily activities. The amount of food assimilated and the growth of the body components was calculated bimonthly. During the course of the present observation, eight to ten of the experimental urchin were dissected bimonthly, and their test, Aristotle's lantern, gut and gonad were separately removed with care so as to avoid any damage. In the present study, it should be noted that the test consist of the test proper, the epidermis, the tissue of coelomic lining and the water vascular system, and that Aristotle's lantern contains the pharynx. The tissues removed from the sea urchin body and algae offered to the sea urchin were placed in a drying oven at 90°C, until constant weight was achieved. Faeces, which settled on the bottom of the aquarium during the experiment, were siphoned out together with aquaria water, and filtrated under suction through a filter paper whose dry weight had been measured. The faeces weight was estimated as the difference between the dry weight of faeces with the filter paper and that of the filter paper alone. The dry substances were minced in a meat grinder. Large aliquots were retained and were stored in a desiccator. All samples used for chemical analysis were weighed to 0.1 mg on an analytical balance.

To determine total nitrogen, a given sample was digested in sulphuric acid with copper sulphate as a catalyst over electric heat, and from the digest the ammonia was distilled with a steam distillation micro-Kjeldahl apparatus.

Fat was extracted from the dried material with a semi-micro Soxhlet extraction apparatus with a 30 ml distilled flask. Anhydrous ether was used as the solvent. The extraction was run continuously for at least 3 hours. The ether was evaporated from the distilling flask, and the amount of fat which had accumulated was determined by weighing the flask before and after distillation.

Ash content was determined by heating samples at 800°C in a muffle furnace. The samples were weighed on an analytical balance, weighed, heated, and reweighed after cooling.

Carbohydrate content was computed by subtracting the sum of the dry weight of protein nitrogen, fat and ash in the sample from the dry weight of the whole sample.

The average amounts of certain chemical elements in the gut, test, lantern and gonad was determined bimonthly. The results are given in Figure 35. No seasonal variations were noticed in the chemical elements in the test and the lantern, but the chemical components in the gut and the gonad fluctuated considerably with successive months. The assessment of the chemical components in each tissue is assessment of organic products constructed by the sea urchin during each two months. Consequently, it is possible to learn the dynamics of organic production with progressive growth by the comparing the changes in the content of chemical elements in body components with the amounts of the nutrients absorbed.

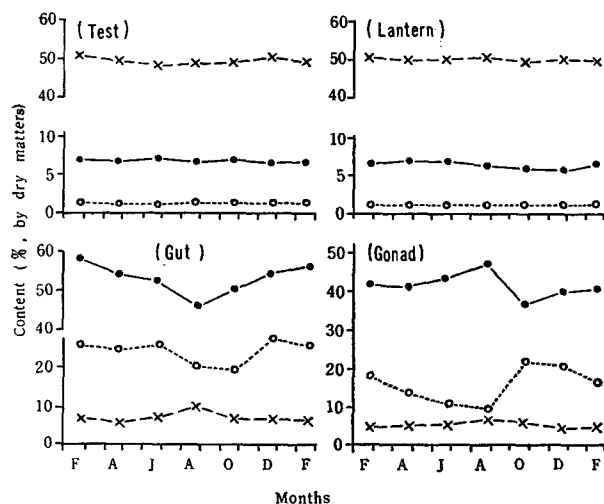

Figure 35. Seasonal change in certain chemical elements in the test, lantern, gut and gonad of *Strongylocentrotus intermedius*. ●: Crude protein, ○: Crude fat, ×: Crude ash.

The weight of non-gonad tissue (viz. test, lantern and gut) was computed from the average diameter of the sample urchins and the average gonad weight was obtained from the experimental urchins for successive two-month intervals. The results are shown in Table 25, where the weight of all the tissues are expressed as dry weight.

Table 25. Dry weight of test, lantern, gut and gonad of sea urchins for successive two-months intervals

Group	Date	Test diameter (mm)	Dry weight (gr)			
			Test	Lantern	Gut	Gonad
1-year-old groups	Feb., 22	18.60	0.782	0.1150	0.0360	0.0211
	Apr., 23	24.72	1.663	0.2103	0.0810	0.0521
	June, 22	30.31	2.849	0.3238	0.0777	0.5848
	Aug., 21	32.94	3.554	0.3865	0.0862	1.1260
	Sept., 16	33.43	3.696	0.3987	0.0890	1.1482
	Sept., 22	34.03	3.876	0.4143	0.0925	0.2204
	Oct., 16	34.47	4.010	0.4256	0.1025	0.2100
	Dec., 15	36.31	4.601	0.4752	0.1650	0.3086
	Jan., 30	37.38	4.967	0.5054	0.1754	0.6244
2-year-old groups	Feb., 22	38.74	5.463	0.5454	0.1776	0.0444
	Apr., 23	40.04	5.961	0.5848	0.2025	0.7002
	June, 22	41.24	6.445	0.6226	0.1454	1.8246
	Aug., 21	42.52	6.988	0.6643	0.1493	2.2390
	Sept., 16	42.78	7.101	0.6728	0.1512	2.2611
	Sept., 22	42.78	7.101	0.6728	0.1512	0.8470
	Oct., 16	43.00	7.201	0.6805	0.1692	0.3773
	Dec., 15	43.94	7.626	0.7124	0.2461	0.6763
	Jan., 30	44.70	7.979	0.7386	0.2423	0.8358
4-year-old groups	Feb., 22	54.81	13.691	1.1380	0.3773	0.6102
	Apr., 23	55.20	13.950	1.1550	0.3726	0.9616
	June, 22	55.30	14.020	1.1601	0.2640	2.4321
	Aug., 21	55.30	14.020	1.1601	0.2640	3.8810
	Sept., 16	55.30	14.020	0.1601	0.2640	3.9204
	Spt., 22	55.30	14.020	1.1601	0.2640	1.9218
	Oct., 16	55.52	14.162	1.1693	0.3018	1.7336
	Dec., 15	56.23	14.623	1.2003	0.4120	1.7983
	Jan., 30	57.11	15.251	1.2421	0.4259	1.9970

The amount of growth of each of the tissues during a two-month period was computed as the difference between the dry weight of the tissues at the beginning and end of each two-month. The results are shown in Table 26. Increased amounts of chemical components, such as protein, fat and carbohydrates, were computed by subtracting the contents at the beginning of each two-month period from the contents at the end of each two-month period. Moreover, it was possible to figure the amounts of nutrient assimilated from the nutritional contents in food eaten and in faeces ejected by the sea urchin during each two-month period. It is known that the caloric content of protein and carbohydrate is 4.1 K-cal per gram

Table 26. Amount of food (*Laminaria japonica*) assimilated and amount of absolute growth during each two-months, expressed as grams in dry weight

Group	Duration of rearing (day)	Food ingested (gr)	Faeces excreted (gr)	Food assimilated (gr)	Amount of growth (gr)			
					Test	Lantern	Gut	Gonad
1-year-old groups	60 (Feb.-Apr.)	3.08	1.19	1.89	0.881	0.0953	0.0450	0.0310
	60 (Apr.-June)	5.04	1.53	3.51	1.186	0.1135	-0.0033	0.5327
	60 (June-Aug.)	4.01	1.39	2.62	0.705	0.0627	0.0085	0.5412
	26 (Aug.-Sept.)	0.73	0.29	0.44	0.142	0.0122	0.0028	0.0220
	30 (Sept.-Oct.)	1.73	0.59	1.14	0.314	0.0269	0.0135	-0.9382
	60 (Oct.-Dec.)	4.65	1.69	2.86	0.591	0.0496	0.0625	0.0986
	46 (Dec.-Jan.)	4.41	1.55	2.86	0.366	0.0302	0.0104	0.3158
2-year-old groups	60 (Feb.-Apr.)	11.09	4.06	7.03	0.498	0.0394	0.0249	0.6556
	60 (Apr.-June)	9.76	3.21	6.55	0.484	0.0378	-0.0571	1.1244
	60 (June-Aug.)	8.40	2.88	5.52	0.543	0.0417	0.0039	0.4144
	26 (Apr.-Sept.)	1.22	0.46	0.76	0.113	0.0085	0.0019	0.0221
	30 (Sept.-Oct.)	3.76	2.00	1.75	0.100	0.0077	0.0180	-1.8838
	60 (Oct.-Dec.)	7.51	3.03	4.48	0.425	0.0319	0.0769	0.2990
	46 (Dec.-Jan.)	3.89	1.08	2.81	0.353	0.0262	-0.0038	0.1595
4-year-old groups	60 (Feb.-Apr.)	7.98	3.26	4.72	0.261	0.017	-0.0047	0.3514
	60 (Apr.-June)	15.07	5.52	9.55	0.070	0.005	-0.0086	1.4705
	60 (June-Aug.)	14.24	4.36	9.88	0.000	0.000	0.0000	1.4489
	26 (Aug.-Sept.)	3.24	0.97	2.27	0.000	0.000	0.0000	0.0394
	30 (Sept.-Oct.)	1.68	0.50	1.18	0.142	0.009	0.0394	-2.1868
	60 (Oct.-Dec.)	6.88	2.42	4.46	0.460	0.031	0.1102	0.0647
	46 (Dec.-Jan.)	10.47	4.44	6.03	0.631	0.042	0.0139	0.1987

Table 27. Amount of food (*Laminaria japonica*) assimilated and amount of absolute growth during each two-months, expressed as calories

Group	Duration of rearing (day)	Food ingested (K-cal)	Faeces excreted (K-cal)	Food assimilated (K-cal)	Amount of growth (K-cal)			
					Test	Lantern	Gut	Gonad
1-year-old groups	60 (Feb.-Apr.)	10.90	3.56	7.34	1.966	0.198	0.233	0.143
	60 (Apr.-June)	18.57	4.76	13.81	2.527	0.236	-0.016	2.378
	60 (June-Aug.)	15.40	4.18	11.22	1.503	0.131	0.009	2.277
	26 (Aug.-Sept.)	2.84	0.90	1.94	0.302	0.025	0.012	0.097
	30 (Sept.-Oct.)	6.74	1.84	4.90	0.670	0.056	0.016	-3.948
	60 (Oct.-Dec.)	17.33	5.65	11.68	1.259	0.103	0.428	0.490
	46 (Dec.-Jan.)	16.17	5.23	10.94	0.780	0.063	0.041	1.438
2-year-old groups	60 (Feb.-Apr.)	39.23	12.15	27.08	1.065	0.085	0.122	3.068
	60 (Apr.-June)	35.94	9.98	25.96	1.028	0.079	-0.293	4.896
	60 (June-Aug.)	32.26	8.68	23.58	1.157	0.085	-0.041	1.602
	26 (Aug.-Sept.)	4.84	1.46	3.38	0.218	0.018	0.009	0.096
	30 (Sept.-Oct.)	14.86	6.43	8.43	0.237	0.018	0.135	-7.954
	60 (Oct.-Dec.)	28.00	10.13	17.87	0.908	0.062	0.411	1.487
	46 (Dec.-Jan.)	14.28	3.64	10.64	0.751	0.049	-0.043	0.480
4-year-old groups	60 (Feb.-Apr.)	28.23	9.98	18.30	0.557	0.033	-0.049	1.568
	60 (Apr.-June)	55.52	17.61	37.91	0.150	0.008	-0.550	6.401
	60 (June-Aug.)	54.68	13.80	40.88	0.000	0.000	-0.116	5.986
	26 (Aug.-Sept.)	12.63	3.15	9.48	0.000	0.000	0.000	0.164
	30 (Sept.-Oct.)	6.05	1.71	4.34	0.296	0.021	0.021	-8.400
	60 (Oct.-Dec.)	25.59	8.54	17.05	0.980	0.061	0.711	0.312
	46 (Dec.-Jan.)	38.40	15.16	23.24	1.350	0.094	0.044	0.555

respectively, and that of fat is 9.3 K-cal per gram. The rate of energy flow through a sea urchin body may now be calculated in terms of calories (Table 27).

From the data of Tables 26 and 27, it may be noticed that there are some seasonal variations in the quantity of energy assimilated and in the amount of energy accumulated for growth, and that they are closely related. Both the amount of food (*Laminaria japonica*) consumed and the growth of non-gonad tissue in the winter. In winter the gonad growth is slow. After the spring months at the time feeding ceases, the growth of non-gonad tissue rapidly decreases, but the gonad growth continues steadily. Although the 2-year-old sea urchin differs in the amount of energy used for the formation of new tissues from the 4-year-old sea urchin, the seasonal rhythm is similar. For the 1-year-old sea urchin the energy going into test growth is about 45 per cent of absorbed energy in the winter but it decreases to about 25 per cent in September and October. Since the gonad growth increases with decreasing test growth, the seasonal rhythms of feeding, test growth and gonad growth of 1-year-old sea urchin may be similar to those of adults.

The weight of the gonad decreased between August and October (Tables 26 & 27). As spawning took place between late September and early October under aquarium conditions, the amount of the decrease in the weight of the gonad is considered to be approximately the weight of the gametes ejected. This value, therefore, is assessed as the energy stored during the above period.

An energy budget for an individual sea urchin throughout a year (342 days) was summarized in terms of energy unit (calories) as shown in Table 28. The efficiency of growth may be expressed either as the percentage of the energy of food ingested which went into new protoplasm or as the percentage of energy assimilated which went into new protoplasm. The first ratio is referred to as the gross efficiency and the second is called the net efficiency of growth. The gross efficiency ranged from 19.7 per cent for 1-year-old urchins to 8.5 per cent for 4-year-old urchins, and the net efficiency of growth ranged from 28.1 per cent to 12.4 per cent. Thus, the percentage of the energy which went for growth decreased as age

Table 28. Energy budget for an individual sea urchin, *Strongylocentrotus intermedius*, throughout a year (342 days)

Items (K-cal/year)	1-year-old groups	2-year-old groups	4-year-old groups
Food : Food ingested	87.95	169.41	221.10
Faeces excreted	26.12	52.47	69.90
Food assimilated	61.83	116.94	151.20
Growth: Test	9.003	5.364	3.333
Lantern	0.813	0.396	0.217
Gut	0.724	0.300	0.245
Gonad	6.823	11.533	14.986
Total production	17.363	17.593	18.781
Gametes ejected	3.948	7.858	8.400

advanced. Since the energy assimilated equals the sum of the energy of growth and the energy of respiration, it is indisputably evident that the energy used for maintenance increases with successive age.

Figure 36 indicates schematically the rate of energy flow through the body and the successive transformation of the energy. A certain amount is excreted as energy wasted in faeces, while most of the rest (ca. 70%) is assimilated. The energy used for muscular work and maintenance is the largest proportion of absorbed energy, and is lost to the surroundings as heat. During the course of the present series of experiments, it is assumed from Figure 36 that about 80 per cent (in the case of 1-year-old urchins) to 90 per cent (in the case of 4-year-old urchins) of assimilated (absorbed) energy is lost to the surroundings as heat. The energy used for the development of gonad tissue corresponds to about 7 per cent of the energy input. On the other hand, the rate of the energy used for the production of non-gonad tissue to the energy input decreases markedly with increasing age. This rate is 12 per cent in an 1-year-old animal reaching first maturity, while it becomes 3.9 per cent in 2-year-old urchin and it decreases to only 1.7 per cent in 4-year-old urchin. Since the energy lost as reproductive matter has ranged from 4 per cent to 5 per cent of the energy input, the rate of the energy stored within the body to the energy input is computed at about 15 per cent in 1-year-old urchins, about 8 per cent in 2-year-old urchins, and 5 per cent in 4-year-old urchins. Thus, it is obvious that the rate of flow of energy through the sea urchin body differs markedly at different seasons and at different stages in the sea urchin's development.

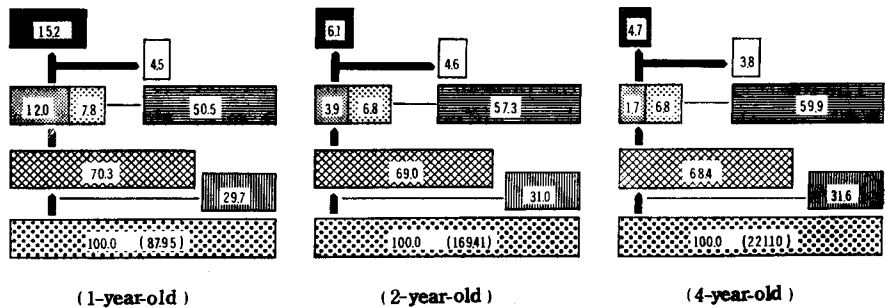

Figure 36. Scheme showing the rate of energy transformation. : Food ingested, : Faeces excreted, : Food assimilated, : Growth of non-gonad tissue, : Growth of gonad, : Loss as heat, : Gametes ejected, : Product retained. The numbers in the column indicate the rate of energy transformation, expressed as percentage. In the lowest column the numbers in parentheses are the amount (K.cal per year) of food ingested.

2. Utilization of protein nitrogen for growth

From the nitrogen content of the sample sea urchins which were dissected at the beginning of the experiment the nitrogen content of all the sea urchins was estimated. This information is recorded in Table 29. The nitrogen content of

Table 29. Amount of protein utilized by

Group number	Duration of rearing (day)	Test diameter at beginning of exp. (mm)	Protein content (mg/day)			Absorption efficiency of protein (%)
			Food ingested	Faeces excreted	Food assimilated	
I	150	18.55	6.2283	1.9892	4.2391	68.06
II	150	28.70	11.1050	3.4814	7.6236	68.65
III	120	38.74	14.9934	4.7690	10.2244	68.19
IV	120	46.83	17.6821	5.5557	12.1264	68.64
V	120	54.77	20.2870	5.7966	14.4904	71.73

each sea urchin at the end of the experiment is also shown in this table. The difference between these two figures shows the amount of nitrogen which the sea urchins retained from the food they assimilated during this experiment.

Nitrogen retained by the sea urchin is used (1) for growth (construction of new body components), (2) for tissue and endocrine replacement, and (3) for oxidation metabolism (Baldwin, 1957). Table 29 shows the relationship between the protein nitrogen absorbed and protein nitrogen retained by the sea urchin. Retained protein shown in column 12 of Table 29 corresponds to protein used for construction of new body components. Neither the amount of protein required for the replacement of body tissue breakdown nor the protein used for oxidative metabolism has been determined. Those two uses of protein have been lumped together as residual nitrogen in column 13 of Table 29.

The relationship between the protein nitrogen absorbed and the protein nitrogen used for growth by sea urchin of different sizes is the most significant feature of the nitrogen balance. The utilization of protein for growth has been determined as follows:

$$\text{Utilization of protein nitrogen for growth in \%} = \frac{\text{Increased amount of protein nitrogen in the tissue}}{\text{Protein nitrogen absorbed}} \times 100$$

The result calculated has been shown in the last column of Table 29, which indicates a close relationship between the diameter of the sea urchin at the beginning of the experiment and the utilization of protein nitrogen for growth. Protein utilization by the sea urchin appears to decline in a curvilinear fashion from about 61 per cent for the urchins of 18.5 mm diameter to 37 per cent for the largest urchins (54.8 mm in average diameter) used in the present experiment. From the above results, it can be seen that the ability of the sea urchin to use nitrogen for growth decreases with increasing size.

Growth in weight is probably affected more directly by the retention of protein than by any other foodstuff. Therefore, the amount of absorbed protein

different size-groups of the sea urchin

Test	Protein retained (mg/day)				Residual protein (mg/day)	Utilization of efficiency of protein (%)
	Lantern	Gut	Gonad	Total		
0.8271	0.0856	0.1325	1.5502	2.5954	1.6437	61.22
0.9884	0.0877	0.0924	3.1767	4.3452	3.2784	57.00
0.4745	0.0341	-0.1044	3.9833	4.3875	5.8369	42.91
0.3152	0.0231	-0.2249	4.6738	4.7872	7.3392	39.44
0.1540	0.0105	-0.3775	5.6140	5.4010	9.0894	37.27

Table 30. Comparison between the amounts of absorbed protein and that of retained protein

Number of group	Test diameter at beginning of exp. (mm)	Protein absorbed (mg/day)	Protein retained (mg/day)	Amount of absorbed protein required for a gain in retained protein (mg/day)
I	18.55	4.24	2.60	1.57
II	28.70	7.62	4.34	1.75
III	38.74	10.22	4.39	2.33
IV	46.83	12.13	4.79	2.53
V	54.77	14.49	5.40	2.68

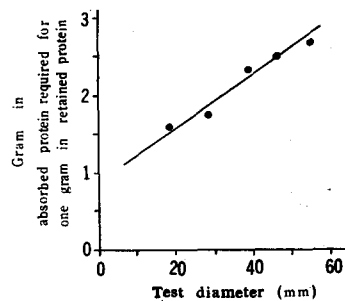
Figure 37. Relationship between the amount of absorbed protein required for a gain in retained protein of one gram and the size of the sea urchin. The urchins were supplied with *Laminaria japonica*.

required for a gain in retained protein was recalculated (Table 30) from the results of Table 29, and was plotted to the test diameters at the beginning of the experiment as shown in Figure 37. The regression coefficient is 0.9788, and this regression correlation is statistically significant. This calculation brings out the great difference in the ability of animals of different sizes to utilize protein for a gain in retained protein. The data of Tables 24 and 29 are retabulated in Table 31 to show a relationship between the increased amount of body components and that of

Table 31. Relation between the increasing amount of body components and that of protein retained

Number of group	Duration of rearing (day)	Dry weight of body tissue (gr)			Protein (gr)			Amount of retained protein required for a gain of body tissue of unit weight (gr)
		At beginning of exp.	At end of exp.	Increased amount	At beginning of exp.	At end of exp.	Increased amount	
I	150	0.9550	4.6312	3.6762	0.0682	0.4722	0.4040	0.1099
II	150	2.8661	7.8610	4.9949	0.1845	0.8361	0.6516	0.1364
III	120	6.2270	9.1830	2.9564	0.3898	0.9161	0.5263	0.1780
IV	120	10.1913	13.0246	2.8333	0.6345	1.2089	0.5744	0.2027
V	120	15.3149	18.1232	2.8083	0.9438	1.5926	0.6488	0.2310

protein retained. This table shows that the increment in weight was from 1.18 in large urchins (the 4-year-old group) to 4.85 in small urchins (the 0-year-old group). The amount of retained protein necessary for a gain of one gram in body tissue is shown in Figure 38 as a function of the weight of the animal at the beginning of the experiment. From the data, the following linear equation can be derived; $RP=0.0084 W+0.1105$ where, RP is grams the retained protein required for one gram gain in weight, and W is the beginning weight in grams of the sea urchin. Using the relationship expressed above, it is possible to estimate the amount of protein necessary for any specified increment of growth in weight. The number of grams of protein required by a urchin to grow from W_1 to W_2 can be found by calculating the area of a trapezoid by W_1 , W_2 and the slope of the regression line.

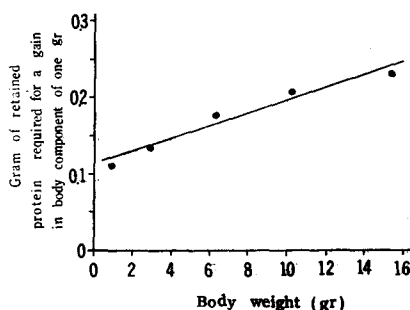

Figure 38. Amount of retained protein required for one gram gain in weight of body tissue. *Laminaria japonica* were offered to the sea urchins as food.

3. Food required for maintenance

The amount of food required for replacement was estimated by two experiments; the first one undertook to determine the amount of food which an urchin much assimilate if it is neither to gain nor to lose weight, and the other to meas-

ure the nitrogen excreted from an urchin fed with non-protein food. During starvation, nitrogen for replacement of tissues and of endocrines broken down in catabolic processes depends upon the mobilization of the tissue nitrogen. So, the amount of the nitrogen excreted by an urchin receiving non-nitrogenous diet has to be equivalent to the minimum amount of protein required for maintain nitrogen equilibrium.

(a) Replacement amount of food

Table 32 shows the relationship between the amount of food assimilated and the growth of the body components of sea urchins during the experimental feeding period (50 days or 60 days). It has already been shown in Table 18 that there are considerable differences in the daily amounts of food eaten by sea urchins when various kinds of sea-weeds are offered. The maximum amount of growth is primarily related to the greatest amount of food assimilated which can handled by the digestive capacity of the animal.

Table 32. Relationship between the amount of food assimilated and the growth of the body components of sea urchins during the experimental feeding period (about 50 days)

Sea-weeds offered to <i>S. intermedius</i>	Food ingested (mg/day)	Faeces excreted (mg/day)	Food assimilated (mg/day)	Assimilation efficiency (%)	Amount of growth (mg/day)				
					Test	Lantern	Gut	Gonad	Total
<i>Ulva pertusa</i>	83.01	17.00	66.01	79.8	10.72	0.70	0.30	9.41	21.13
	83.60	18.10	65.50	78.2	11.61	0.42	0.20	5.87	18.10
	37.12	7.49	29.63	79.8	3.41	0.21	0.11	2.62	6.35
	27.73	4.92	22.81	82.6	2.90	0.21	0.11	1.23	4.45
	20.09	3.25	16.84	83.2	0.25	0	0	1.01	1.26
<i>Alaria crassifolia</i>	228.60	63.10	165.50	72.4	21.00	1.62	-0.02	28.07	50.67
	131.10	29.83	101.27	77.1	15.40	1.00	-0.05	10.45	26.80
	50.59	9.04	41.55	82.1	7.40	0.46	-0.27	2.01	9.60
	29.24	4.91	24.33	83.2	1.00	0.08	-0.42	0.28	0.94
	15.94	2.37	13.57	85.1	0.40	0.04	-0.30	-0.51	-0.37
<i>Laminaria japonica</i>	204.86	70.55	134.31	65.7	6.25	0.44	0.36	16.56	23.61
	157.31	50.21	107.10	68.1	5.48	0.11	0.32	13.20	19.11
	136.82	38.20	98.62	72.0	8.86	0.66	0.37	6.84	16.73
	116.21	27.82	88.39	75.9	8.86	0.66	0.37	4.94	14.83
	50.16	9.88	40.28	80.0	3.20	0.20	0.10	2.02	5.52
	31.83	5.75	26.08	81.8	0.20	0	0	1.50	1.70

The amount of protein nitrogen which an urchin must ingest if it is neither to gain nor to lose retained protein nitrogen corresponds to the maintenance requirement of protein nitrogen. Therefore, it is possible to estimate the amount of protein nitrogen required by an animal to maintain the protein nitrogen

Table 33. Relationship between the amount of protein nitrogen retained in the body and the amount of protein nitrogen absorbed by the sea urchin when fed varying amount of food. The experimental feeding period is about 50 days.

Sea-weeds offered to <i>S. intermedius</i>	Nitrogen absorbed (mg/day)	Nitrogen retained (mg/day)				
		Test	Lantern	Gut	Gonad	Total
<i>Ulva pertusa</i>	2.664	0.148	0.073	0.027	0.583	0.831
	2.662	0.124	0.043	0.018	0.384	0.569
	1.194	0.036	0.021	0.001	0.179	0.237
	0.906	0.010	0.021	0.001	0.087	0.140
	0.663	0.001	0	0	0.004	0.065
<i>Alaria crassifolia</i>	4.683	0.225	0.018	0	1.682	1.925
	2.805	0.165	0.010	0	0.695	0.860
	1.129	0.079	0.005	-0.002	0.128	0.210
	0.658	0.011	0.001	-0.004	0.015	0.023
	0.365	0.004	0	-0.003	-0.036	-0.035
<i>Laminaria japonica</i>	2.287	0.024	0.005	0.033	1.129	1.191
	1.819	0.059	0.001	0.029	0.866	0.955
	1.669	0.095	0.007	0.033	0.448	0.583
	1.491	0.095	0.007	0.033	0.323	0.458
	0.677	0.034	0.002	0.001	0.096	0.133
	0.438	0.002	0	0	0.096	0.098

equilibrium from the correlation between the amount of protein nitrogen retained in the body and the amount of protein nitrogen absorbed by the sea urchin when fed varying amounts of food. This information for sea urchins ranging from 45 mm to 50 mm in diameter is shown in Table 33. It is clear from Table 33 that progressive decrease of the nitrogen absorption provokes a decrease in the amount of nitrogen retained in the body components (viz. test, lantern, gut and gonad). Moreover, the decrease in the amount of retained protein nitrogen is initiated when the amount of protein absorbed is less amount than some critical point, which may correspond to the maintenance requirement of protein nitrogen. Nitrogen compounds stored in gonadal tissue are mobilized to maintain the supply of protein nitrogen during starvation (Lasker & Giese, 1954). This explains the negative value of nitrogen retention recorded in gonadal tissue.

A theoretical portrayal of the influence of the rate of assimilation upon the amount of growth can be established by using the regression calculation. In order to calculate more precisely the amount of food necessary to replace old tissue the correlation between food assimilated and growth was computed by the method of least squares. The correlation between protein nitrogen retained and protein nitrogen absorbed, moreover, was computed in order to estimate the amount of nitrogen replaced, in the same manner. The regression lines are shown in Figures 39 and 40, and the regression formulae are summarized in Table 34. The

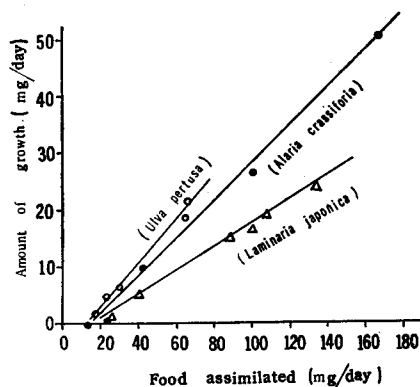

Figure 39. Relationship between growth rate and the assimilation rate of food eaten

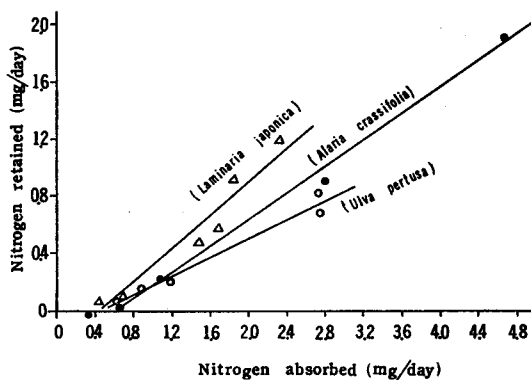

Figure 40. Relationship between nitrogen absorption and nitrogen retention

amounts of food and nitrogen required for replacement of tissues are indicated by the interception of the regression lines on the x -axis. These values are shown in the last column of Table 34. Although there are some variations, an independent method to measure the amount of food necessary for replacement of tissues yielded values ranging between 13 mg and 17 mg per day in dry weight of food, and between 0.4 mg and 0.7 mg per day in protein nitrogen.

(b) Endogenous nitrogen excretion

The animal is continuously engaged in metabolizing organic materials, either breaking them down to provide energy, or building them up into specific products or tissues. Among the foodstuffs which are metabolized by the animal, carbohydrate and fat are finally transformed into water and carbon dioxide, and they are readily eliminated. The nitrogenous compounds, predominantly proteins and nucleic acids, are derived from the α -amino-nitrogen of amino acids which are split off from protein through the action of proteolytic enzymes. Amino acids are deaminated for the most part to ammonia. Ammonotelic animals, such as

Table 34. Regression formulae for the determination of foods or nitrogen required for maintaining nitrogen equilibrium. In each formula, Y is the rate of growth of or nitrogen retention, and X is the rate of the food assimilation or of nitrogen absorption.

a) Assimilated amount of food required for replacement

Sea-weeds offered to <i>S. intermedius</i>	Regression formula	Replacement amount (mg/day)
<i>Ulva pertusa</i>	$Y=0.3839 X-5.1586$	13.44
<i>Alaria crassifolia</i>	$Y=0.3368 X-5.7934$	17.20
<i>Laminaria japonica</i>	$Y=0.2019 X-3.0663$	15.19

b) Absorbed amount of nitrogen required for replacement

Sea-weeds offered to <i>S. intermedius</i>	Regression formula	Replacement amount (mg/day)
<i>Ulva pertusa</i>	$Y=0.3177 X-0.1456$	0.458
<i>Alaria crassifolia</i>	$Y=0.4500 X-0.2677$	0.595
<i>Laminaria japonica</i>	$Y=0.5927 X-0.2583$	0.436

various echinoderms, eliminate ammonia as the major end-product of protein catabolism.

About 30 per cent of the total nitrogenous excretion of *Paracentrotus lividus* is in the form of ammonia (Delanuey, 1931). Ammonia is volatile and may be lost from aerated alkaline solutions. Accordingly, a test was set up to detect the possible loss of ammonia under aerated aquaria conditions. Ammonium chloride was added to sea water to make the concentration of nitrogen about 0.5 ppm. Then, the nitrogen concentration was measured in the sea water at the beginning of the test and each day thereafter for 5 days. No progressive loss of ammonia from the sea water could be detected, although the concentration of nitrogen varied from 0.5 ppm to 0.47 ppm. These changes were within the range of error of the direct nesslerization procedure. It was concluded that no ammonia would be lost from the excretory products of the sea urchin kept in aerated aquaria for 5 days.

Figure 41 shows the excretion of nitrogen by sea urchins of 62.8 mm and 51.1

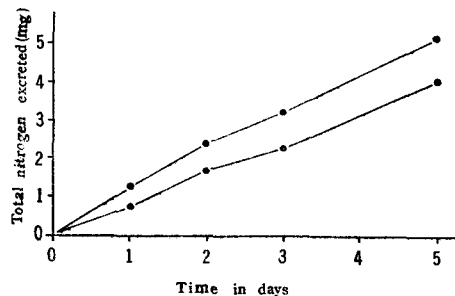

Figure 41. Total nitrogen excreted by the sea urchin during the course of 5 days. At the beginning of the experiment the diameter of the sea urchin measured 62.8 mm in upper animal and 51.1 mm in lower one.

mm in diameter during the course of 5 days. The nitrogen excreted per day can be computed from the total amount of nitrogen excreted during the experiment.

Each sea urchin, between 33 mm to 74 mm in test diameter, was placed in a separate aquarium with an accurately measured volume of sea water. This series of experiments was initiated after 3 or 5 days of a non-nitrogen diet of starch and agar-agar. All aquaria were continuously aerated. The nitrogenous excretory products accumulated in the water. The relationship between the amount of nitrogen excreted per day and the diameter of the sea urchin can be clearly demonstrated by plotting the data for each individual (Figure 42). Although there

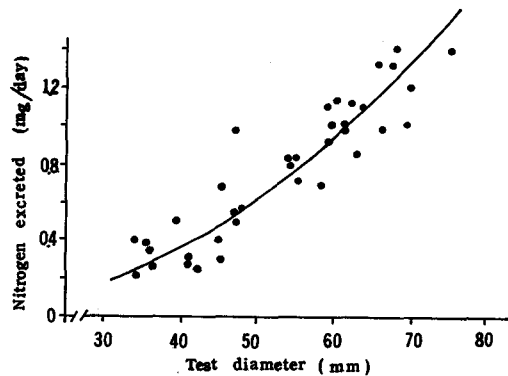

Figure 42. Relation between the amount of nitrogen excreted per day and the diameter of the sea urchin. During the experimental periods, the ration of non-nitrogen diet was provided as an energy source.

was considerable individual variation, which may be attributed to the physiological conditions of the specimens, the following calculation of the exponential regression was made; $N=0.00009324D^{2.2570}$ where, N is the total nitrogen excreted in milligrams per day, and D shows the diameter of the test in millimeters. The 95 per cent interval of confidence of the average nitrogen excretion of sea urchins of any size may be calculated from the following formula;

$$l_{1,2} = (2.2570 D_0 - 4.0304) \pm 0.2651 \sqrt{0.0263 + \frac{(D_0 - 1.7156)^2}{0.3525}}$$

where, D_0 is the logarithmic value of test diameter and l_1 and l_2 indicate upper and lower limits of the 95 per cent confidence interval of average nitrogen excretion. By substituting the logarithmic value of 45 and 50 for D_0 in the formula, we obtain the values of 0.45 mg and 0.63 mg of nitrogen per day, and the 95 per cent confidence interval is the range from 0.43 mg per day to 0.70 mg per day per individual. Considering that the experiments were performed in an entirely different manner, the agreement of a base level of protein metabolism is remarkably close.

VI. General Considerations

In the previous chapters the author clarified the various aspects of the growth and the food consumption of the sea urchin, *Strongylocentrotus intermedius*, in southern Hokkaido. In this chapter, first, the author will discuss the results reported in each chapter. Second, I will propose descriptions of the life cycle of the sea urchin on the basis of these findings.

The test of the sea urchin has two dimensions, diameter and height. If the diameter differs in its pattern of growth from the height, then the profile of diameter differs in its pattern of growth from the height, then the profile of test growth would have to be indicated by some value, which includes simultaneously changes in both dimensions.

The studies dealing with the shape of the test of *Echinoidea* are by Moore (1934, 1935), who illustrated the decrease of height-diameter ratio with increasing the diameter of *Echinus esculentus*, and Bull (1938), who reported the variability of the ratio of the height to the diameter of *Psammechinus miliaris* under aquarium conditions. Swan (1958) has shown that, in his studies on *Strongylocentrotus drobachiensis*, that regression of height to diameter is divided into several different groups, each of which makes up a more or less definite straight line. Recently, in a study on *Lytechinus variegatus*, Moore et al. (1963) has reported that the sea urchins which came through the cold winter as small individuals show a marked difference in shape from the general trend, and that a departure from normal shape may be only temporary. In the present observation using *Strongylocentrotus intermedius*, no significant difference among the regressions of height to diameter was found in different seasons or localities (Tables 6, 7, 8 and 9). Although the same population was not re-examined the following year to see whether the shape characteristics persisted, it is assumed that they have the ability to modify their shapes in the direction of what is normal during growth, even if they differ from normal shape because of some aberrant conditions. Therefore, it is concluded that the linear growth of the test diameter represents the general profile of the test growth and that a cessation of increment in the diameter of the test means a suspension of growth of the test.

Variations in the growth rate of the test diameter have been reported by Moore (1935) in a study of *Echinus esculentus* and by Swan (1961) in a study on *Strongylocentrotus drobachiensis*. Swan (1961) proposed that the variations in linear growth might be attributed to differences in the food available, differences in other environmental factors or to some combination of these factors. In studies on *Echinus esculentus*, *Hemicentrotus pulcherrimus*, *Strongylocentrotus purpuratus* and *St. franciscanus*, it has been mentioned that some variation occurs in the year-to-year ratio of gonad volume to total body weight, and that it may be possible to attribute such variations of fluctuations in the agal crop each year (Moore, 1934

Kawana, 1938 b; Lasker & Giese, 1954; Bennett & Giese, 1955). According to Boolootian & Giese (1959) the most striking difference between the two widely separated populations of *Strongylocentrotus purpuratus* is the higher gonad indexes for the northern population. The gonads are approximately twice the size of those of the southern population prior to spawning. They suggested that factors involved in the growth of gonads appear to be light, temperature and food. In a study on Echinodermata, *Asterias rubens*, Vevers (1949) has reported that a poorly fed population shows no or little gonad growth, whereas a well fed population has vigorous growth.

Growth is the construction of new tissues, and the amount of growth can be found by subtracting the energy used for basal metabolism and activity from the energy ingested. Growth may be affected by numerous biotic and abiotic factors. The results mentioned in chapters IV and V strongly suggest that the amount and the kind of foodstuff ingested are the most essential factors, and that the other biotic and abiotic elements of the environment also influence the rates of digestion and absorption metabolism. In this sense, the mutual correlation between nutritive absorption and the rate of growth may provide a helpful information for further investigations into factors affecting growth.

Field studies on the feeding ecology of sea urchin have been limited to a description of composition and quantity of food found in the gut. Much literature has accumulated on this subject. This information is summarized in Table 35. From this table, general speaking, the food of the sea urchin is predominantly sea-weed, although a small amount of other food has been found in various species of sea urchin. For example, gastropods, hydroids, sponges, gammarids, polychaetae and small bivalves have been found in the sea urchin gut. It is assumed that these animals living on algal fronds were ingested together with the algae by the sea urchin. If starved, *Strongylocentrotus purpuratus* were found to ingest almost anything offered them even boiled eggs, boiled potatoes and vegetables, as well as fresh sea-weeds (Lasker & Giese, 1954). *Hemicentrotus pulcherrimus* and *Anthocardia crassispina* ingested the meat of fish and bivalve, but only as small amount (Oshima et al., 1957). From the above observations it appears that these species of sea urchin are omnivorous. However, as the guts of sea urchins collected from natural habitats have been filled with fragments of various algae (green, red and brown), it is reasonable to conclude that the food of the sea urchin belonging to *Regularia* consists predominantly of fresh algae in regions where such food is available in quantity, and of algae debris elsewhere.

The gut of the larval specimens (less than 10 mm in diameter) of *Strongylocentrotus intermedius* has contained largely diatoms and detritus. It has been said that the feeding habits of the larval urchins may possibly be connected with larval death (Nataf, 1954; Kawamura & Hayashi, 1963). Since minimization of larval death means an increase in the number of sea urchins, further investigations

Table 35. Food found in the gut of sea urchins

Species of sea urchins	Food items (Gut contents)	Author
<i>Strongylocentrotus drobachiensis</i>	Sea-weeds, Protozoa, Radiolaria, Diatoms	Scott (1901)
	Detritus, Sponge, Hydroid, Gammarida, Barnacle	Blegvad (1915)
	Sea-weeds, Bivalve larvae	Jensen (1915)
	Sponge, Hydroid, Polychaeta, Diatoms, Crustacea	Eichelbaum (1910)
	Sea-weeds (<i>Zostera</i> , <i>Ulva</i> , <i>Fucus</i>), Diatoms	Wesse (1925)
	Brown algae	Scattergood (1947)
<i>S. purpuratus</i>	Sea-weed (Phyllospadix)	Lasker & Giese (1954)
<i>S. intermedius</i>	Sea-weeds	Kawamura (1960)
<i>Hemicentrotus pulcherrimus</i>	Sea-weeds	Kawana (1938b)
<i>Arbacia punctulata</i>	<i>Fundulus heteroclitus</i> (fish)	Parker (1932)
	Sea-weeds, Hydroid	Van derHeyde (1922)
	Sea-weeds (Red and Brown algae), Sponge	Harvey (1956)
	<i>Fucus vesiculosus</i>	Stott (1955)
<i>Echinus esculentus</i>	Sea-weed (<i>Laminariaceae</i>)	Van derHeyde (1922)
<i>Psammechinus miliaris</i>	Sea-weeds	Bull (1938)
<i>Lytechinus anamesus</i>	Sea-weeds	Lasker & Giese (1954)
<i>Toxopneustes</i> sp.	Crustacea	Van derHeyde (1922)
<i>Sphaerechinus</i> sp.	Crustacea	Van derHeyde (1922)

into food consumption may be helpful in conserving the sea urchin resources.

There has been very little work done on changes in contents of the gut with progressive feeding and digestion. Oshima et al. (1957) observed the digestive process of two species of Japanese sea urchins, *Hemicentrotus pulcherrimus* and *Anthocidaris crassispina*, collected from their natural habitat. Lasker & Giese (1954) have reported that the ingested food remains in the gut for a long period of time, which suggests a very slow rate of digestion. Their findings agree with the present author's observations. It has already been clarified from the previous report concerning the histological and histochemical contribution of the food canal of *Strongylocentrotus intermeidus* (Fuji, 1961) that absorption takes place in the lumen of the stomach, and that the intestine and the rectum act both as absorptive organs and as a conductive tube for the undigested food materials. In *Strongylocentrotus purpuratus*, it has been shown that the digestion and absorption of the nutritive constituents in the food occurs mainly in the oesophagus and adjacent festoons of the stomach (Farmanfarmaian & Phillips, 1962). The food mass which remains in the gut for a long period of time dominates in the last half of the intestine and in the rectum as shown in Figure 31. The above information strongly suggests that not much digestion takes place in these areas. Since virtually no faecal pellets are ejected during starvation (Figure 30), most of the decrease in the

contents of the gut during this period may be attributed to digestion and absorption. Therefore, this study shows that the digestion and absorption of the utilizable materials in the food is virtually achieved within about 2 to 4 days. From the time required for the gut to become full (Figure 32), the time required for passage through the gut was estimated to be one day for *Laminaria japonica* and about 3 days for *Ulva pertusa*. Maximum gut contents were 4.6 per cent and 3.1 per cent of body weight in *Laminaria japonica* and *Ulva pertusa* respectively (Table 20). When *Laminaria japonica* and *Ulva pertusa* were offered as food, the value of the daily rate of feeding was 5.8 per cent and 1.0 per cent as has already been shown in Table 18. From this the time required for passage through the gut can also be computed by dividing the maximum gut contents by the daily rate of feeding. The result of this calculation agrees well with the result obtained from Figure 32.

Since the decreased amount of food mass, shown in Figure 30, is attributable to digestion and absorption of food, the degree of decrease may be useful to estimate, roughly the rate of nutritive absorption. From Figure 30, the maximum rate of absorption of *Laminaria japonica* is appraised at about 80 per cent and that of *Ulva pertusa* at about 85 per cent. The above values roughly shows the degree of nutritive absorption when the sea urchins are starving. If feeding is continuous, the average time of retention in the gut is about one day for *Laminaria japonica* and about 3 days for *Ulva pertusa*, and only about 55 per cent of the former and about 75 per cent of the latter are absorbed.

From the above it may conclude that when a good supply of food is available the food mass in the gut is propelled towards the anus by muscular constriction of the gut, is replaced by incoming the food mass, and is discharged as faecal pellets before all possible digestible elements are absorbed food. On the other hand, when the food supply is not sufficient the food mass in the gut is propelled slowly and the time of retention in the gut is prolonged because less food is coming in. As a result more of the nutrients are absorbed. In other words, it seems likely that when feeding is continuous the sea urchins might be wasting much of the organic material available. This assumption is supported by the report by Lasker & Giese (1954) that, when slowly eliminated, the algae in the faeces were found to be fairly completely decomposed, and that, when feeding is continuous, the algal pellets appear to be incompletely digested.

In the natural population, the profile of growth of 0-year-old sea urchins (under 30 mm in diameter) differs from that of adult sea urchins (2-year-old and older). The monthly rate of test growth of the former age group is high throughout the entire year. The monthly rate of test growth of the adult sea urchins, however, is less than 3 per cent, and it ceases all together from spring to autumn. Almost all sea urchins less than one year old have neuter gonads. On the other hand, 1-year-old sea urchins show some development of sex products with successive months, and

probably commence becoming part of the spawning population from August to October. Thus, sea urchins less than one year old differ markedly in their gonad development from the 1-year-old sea urchins. Adult sea urchins go through cyclic seasonal change of development and depletion of their gonad, and this is inseparably connected with the growth of the test. There are striking differences in food consumption between a young sea urchin and an adult sea urchin. The amount of food eaten daily by an adult individual markedly declines between July and October, while the food consumption of the young sea urchin remains constant. Besides that, the utilization efficiency of food for growth of the adult urchin is inferior to that of the young urchin. As was shown in chapter V, however, the energy ingested, the energy accumulated as gonad growth, and the energy put into the formation of non-gonad tissue, changes with the seasons. Therefore, we can see that the variations in the profiles of body and gonad growth are manifestations of the rhythm of energy accumulation into the body, and that its change with progressive age is due to the difference in the amount of energy used for the formation of the new tissue. The entire life of the sea urchin (as an individual), from birth to death, may be described from the viewpoint of the energy flow through the body.

Before maturity, most of the energy which goes into stored energy is utilized for growth of non-gonad tissue. Gonad growth has a subsidiary significance. After the attainment of maturity the main part of the energy stored by the sea urchin is used not for linear growth but for the development of the gonad. For older sea urchins, linear growth practically ceases, and most of the assimilated energy is used for maintenance.

Gonad growth, which ensures the continuation of the species, and body growth, which maintains the existence of an individual, are the essential links in the life cycle of the sea urchin. The life cycle of the sea urchin, from the viewpoint of metabolic processes, may be categorized into the following developmental periods:

(1) *Larval period*: This is the developmental period covering the time from the moment of metamorphosis to a full one year after birth. Further studies may describe other stages, such as the free-swimming larval period, newly settled larval period, and so forth. However, the period indicated herein is initiated from the moment of metamorphosis because of the absence of ecological information of the free swimming larvae.

During this period the gonad is neuter, and does not show any developmental processes. Feeding is active throughout the year, and the food resources which enter into the sea urchin's body are continuously utilized for the growth of non-gonad tissue throughout this period. This period falls into two periods according to their food habits; (a) *Pre-larval period*, and (b) *Post-larval period*. The former is from metamorphosis to about 10 mm in diameter. The animals of this period ingest predominantly detritus. The latter covers the time during which

the sea urchins grow from about 10 mm to about 20 mm in diameter. The main food becomes algae.

(2) *Young period*: In this period, the bulk of the energetic resources are used not only for the development of the gametes but also for the growth of non-gonad tissue. The size of their test becomes 25 mm to 30 mm in diameter. They begin to enter the spawning population in autumn. However, they appear to be a subsidiary population for reproduction because of the smallness of their gonads.

(3) *Adult period*: This period begins when the specimen of about 30 mm in diameter. In this period of life the growth of non-gonad tissue is a subsidiary significance. The bulk of the energy absorbed is used for gonad growth, and for the accumulation of reserve material for the support of metabolism during the period of reproduction. Seasonal cyclical changes in the mode of life and in physiological aspects occur during this period as listed below.

a) *Growing season*: This season falls into two parts. i) The season for test growth (November—February): The gonad is in the *Recovering stage*, no remarkable development occurs in gametogenesis. The feeding becomes very active. Intensive growth of the test continues during this season. ii) The season of gonad growth (March—May): Feeding becomes more intense, and most of the energy absorbed is utilized for the gonad, but not for test growth.

b) *Maturing season* (June—August): In this season the gonad is in first a *Pre-mature* and then a *Mature stage*. Food consumption decreases. The growth of the test becomes very slow entirely.

c) *Spawning season* (September—October): Gametes are released during this season so the total weight of the body components of the sea urchin decreases rather than increases. Food consumption declines markedly, and is restricted to two or three times of the maintenance requirement. The test growth ceases. The gonad is in the *Spent stage*.

Figure 43 shows the mutual relation of gonad development, test growth and food consumption in the adult sea urchin throughout the year.

Changes in the size of the population are the result of changes in the relationship between the rate of production and the rate of mortality of the individuals making up the population, and it may be that it is generally limited by food supply. This supposition is supported by Moore et al.'s observation (1963) that the size of the sea urchin (*Lytechinus variegatus*) population is limited by the availability of food. Consequently, the leading problem at present is to clarify the population dynamics of the sea urchin stocks, i.e. the growth and mortality of the sea urchins of every stage of the life cycle, and to investigate the ecology of sea-weeds as an important factor in regulating the sea urchin population. Success in the investigations along these lines may provide methods of increasing the productivity of the sea urchin stocks. The results obtained from the present investigation are considered a useful scaffolding for progress in such studies.

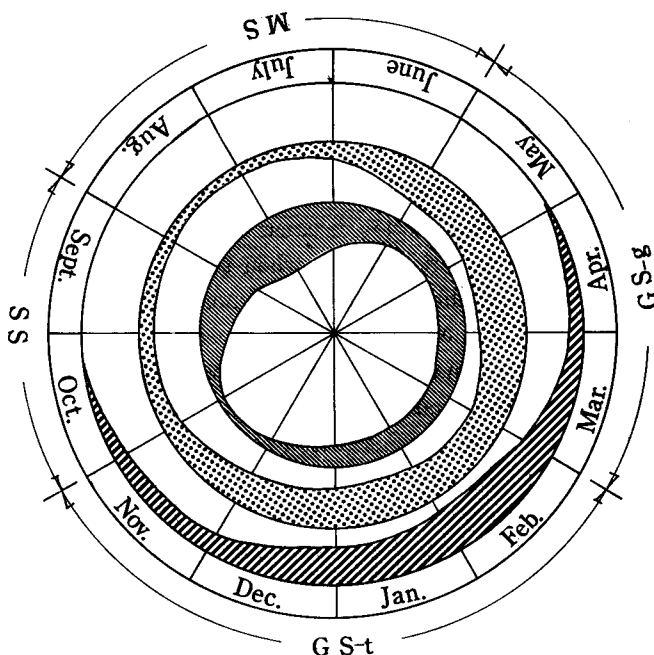

Figure 43. Scheme of the mutual relation of gonad development, food consumption and test growth in the adult sea urchins throughout the year.

▨: Test growth, ▤: Food consumption, ▩: Gonad growth, GS-t: Growing season (for body growth), GS-g: Growing season (for gonad growth), MS: Maturing season, SS: Spawning season.

VII. Summary

In recent years, the annual yield of sea urchins in Japan has amounted to as much as about 20,000 tons. The sea urchins have become an animal resources of economical importance in Japan. However, the practices of conservation and of propagation of this creature, which have been made during the past thirty years in Japan, have not always been successful. Failures may be mainly attributed to the deficiency of ecological knowledge about the sea urchin, so the present study was carried out to clarify details of the ecology of the sea urchin, *Strongylocentrotus intermedius*, which is of commercial importance in northern Japan. The results obtained from the present study are summarized as follows:

1. To compare the size of gonads of adult sea urchins the gonad index was developed. The gonad index is the ratio of the wet weight of the gonad to the total volume of the body. The gonad index of both males and females is at a peak value in July or August, and a minimum value in October or November. The period of *Recovering* gonad is relatively short; nearly half of the animals collected in January possess *Recovering* gonad. After January, this number decreases

and the number of animals with *Growing* and *Pre-mature* gonad correspondingly increases. Sea urchins in the *Spent stage* are most numerous in November. The annual reproductive cycle of the adult population may be broadly divided into four different phases; a) *Recovering phase*, b) *Developing phase*, c) *Maturing phase*, and d) *Breeding phase*.

2. When the increase in the weight of the gonad is plotted on a graph with the increases in diameter of the sea urchin. Two exponential curves intersect at the gonad weight of a specimen of about 32 mm to 35 mm in diameter. A diameter of 30 mm to 35 mm corresponds to the size of the sea urchin at first maturity. The gonad rather suddenly appears and develops when the sea urchin reaches this size. Almost all specimens up to 15 mm in diameter are neuter. In the specimens ranging from this size to 35 mm diameter, it is possible to differentiate the sexes, and the gonad possesses more and more mature gametes as it increases in size. However, the profile of the gonad growth being non-cyclic differs essentially from that of adult specimens.

3. The gonad growth throughout the entire life may be divided into three phases. The first is the gonad growth in the larval specimens under 20 mm in diameter, the second covers the period from the immature stage to first maturity, and the third corresponds to the gonad growth in the adult sea urchin.

4. A suitable exponential formula for the relationship of the test diameter (D_t) to age (t) becomes: $D_t = 69.200 (1 - e^{-0.331(t-0.219)})$.

In adult specimens (more than two years old) the period of test growth is restricted to the late winter and early spring and growth almost ceases the rest of the year. On the other hand, the young urchins (under two years old) grew continuously throughout the year. The rate of growth of the young urchins is markedly higher than that of the adults. The weight of the test varies proportionally to the diameter of the test throughout their life. The diameter—height relationship is $H = 0.5015 D - 0.3142$.

5. No seasonal variation was recognized in the relationship between test diameter (D) and total body weight (W). This relation becomes:

$W = 0.0005272 D^{2.9373}$ This means that their body weight did not decrease even in the spawning season when the gonad weight decreased markedly because of the ejection of gametes. Since an inverse relation exists between the volume of the gonad and the volume of perivisceral fluid, the loss of the total body weight with ejection of the gametes may be replenished by the augmentation of the perivisceral fluid.

6. There is a good correlation between test diameter and the dry weight of the test, lantern, and gut. The regressions for calculating the test weight and lantern weight from the test diameter are the same throughout the year, while the regression for gut weight changes significantly with the successive months of the year.

7. Detritus are predominantly found in the gut contents of larval urchins, but their main food becomes algal when they reach about 10 mm in diameter.

8. Sea urchins do not feed much when the light is more intense than 6,000-lux, but they compensate by feeding more actively at night after such a daytime. The amount of food eaten during 24 hours is not affected by the intensity of the light in the daytime.

9. The amount of food eaten daily per adult specimen (ca. 50 mm in diameter) varies widely according to the kind of sea-weed. The largest amount of food eaten during a day was about 6 per cent of the body weight, and the lowest value was about one per cent. There was a marked decline in the amount of food eaten daily per adult specimen between July and October. Such a decline did not occur in the young specimen.

10. With a good supply of food, the average time of retention of *Laminaria japonica* in the gut is less than one day, and the co-ordinate value of *Ulva pertusa* is 2 or 3 days. It is estimated from the movement of food mass through the gut that the sea urchin, when feeding continuously, absorbs about 55 per cent of *Laminaria japonica* and about 75 per cent of *Ulva pertusa*. However, these foods remain in the gut for a long time during starvation, it is estimated that about 80 per cent of *Laminaria japonica* and about 85 per cent of *Ulva pertusa* are absorbed into the body.

11. The assimilation efficiency varied widely according to the kind of algae. It ranged from 83 per cent (in *Scytosiphon lomentaria*) to 57 per cent (in *Laminaria japonica* and *Condrus ocellatus*). This efficiency increased with rising water temperature and vice versa. The mean value of the assimilation efficiency is about 70 per cent in summer and about 55 per cent in winter, when *Laminaria japonica* is supplied as food. The amount (in dry weight) of food (*Laminaria japonica*) assimilated is at a high level (ca. 270 mg/day/individual) from February to June and falls to about 50 mg/day/individual in September and October.

12. There is no difference in the ability of the sea urchin of different sizes to absorb protein nitrogen from food eaten. The ability of the sea urchin to utilize protein nitrogen for growth appears to decline in a curvilinear fashion with increasing test diameter. When *Laminaria japonica* is used as food, the utilization of protein nitrogen by small urchins of 18.5 mm in diameter is about 61 per cent, and the corresponding value is 37 per cent for large urchins (54.8 mm in diameter). The growth efficiency based on caloric value differs considerably according to the kinds of food; in adult specimens (ca. 50 mm in diameter) this efficiency ranged from 4.5 per cent (in *Agarum cribrosum*) to 28.6 per cent (in *Alaria crassifolia*). No significant difference was found in their ability to assimilate the food eaten. When *Laminaria japonica* was offered to them, the assimilation efficiency averaged about 60 per cent. The growth efficiency decreased as the urchin grew larger, it ranged from 51 per cent for the small urchin (about 20 mm in

diameter) to about 15 per cent for the large urchin (about 55 mm in diameter).

13. The transformation of energy within the sea urchin (as an individual) is represented by the following equation:

$$\text{Input} - \text{Egestion} = \text{Assimilation} = \text{Growth} + \text{Respiration}$$

The efficiency of growth is expressed as the percentage of the energy consumed which is turned into new protoplasm (gross efficiency) or the percentage of energy assimilated that is converted into new protoplasm (net efficiency). The percentage of the energy stored to the energy consumed decreases as the age advances. When *Laminaria japonica* is offered, the gross efficiency decreases from 19.7 per cent for the one year old to 8.5 per cent for the four years old, and the net efficiency of growth ranged from 28.1 per cent to 12.4 per cent.

14. The amount of food required for body maintenance was determined by measuring the amount of food which an urchin must assimilate if it is neither to gain nor to lose weight and by the total amount of nitrogen excreted from an urchin fed with non-protein diet.

The amount of food required for maintenance ranged from 13 mg to 17 mg (dry weight) of algae per day, and the amount of protein nitrogen required for maintenance ranged from 0.4 mg to 0.7 mg per day for sea urchins from 45 mm to 50 mm in diameter.

The following calculation of the exponential function was made between the test diameter (D) and total nitrogen excreted (N) per day per individual of the sea urchins fed a non-nitrogen diet. $N = 0.00009324 D^{2.2570}$ From the above formula, it was estimated that the sea urchin of about 50 mm in test diameter excretes from 0.4 mg to 0.7 mg of nitrogen per day per individual.

15. The life cycle of the sea urchin was outlined on the basis of findings concerning food utilization and organic production and areas requiring further study to increase sea urchin resources were suggested.

References

- Aikawa, H. (1960): *Shigen Seibutu Gaku*. 418 pp. Kanehara Shuppan, Tokyo. (in Japanese).
- Bagenal, B. (1955): The growth rate of the Long rough dob, *Hippoglossoides platessoides* (Fabr.). *J. Mar. Biol. Assoc.*, **34**, 297-311.
- Bennett, J.B. & Giese, A.C. (1955): The annual reproductive and nutritional cycles in two western sea urchin. *Biol. Bull.*, **109**, 226-237.
- Bertalanffy, L. von. (1938): A quantitative theory of organic growth (Inquiries on Growth laws, II). *Human Biol.*, **10**, 181-213.
- (1949): Problem of organic growth. *Nature*, **163**, 156-158.
- Blegvad, H. (1915): Food and conditions of nourishment among the communities of invertebrate animals found on or in the sea bottom in Danish waters. *Rept. Dan. Biol. Stat.*, **22**, 41-78.
- Boldwin, E. (1957): *Dynamic aspects of biochemistry*. Cambridge Univ. Press., Cambridge.
- Bolin, L. (1926): Geotropisms von *Psammechinus miliaris* O.F.M. *Hydrobiol. Hydrograph.*, **16**, 125-129.

- Booolootian, R.A. & Giese, A.C. (1959): The effect of latitude on the reproductive activity of *Strongylocentrotus purpuratus*. *Intern. Oceanogr. Cong.*
- & Lasker, R. (1964): Digestion of brown algae and the distribution of nutrients in the purple sea urchin *Strongylocentrotus purpuratus*. *Comp. Biochem. Physiol.*, **11**, 273-289.
- Bull, H.O. (1938): The growth of *Psammechinus miliaris* (Gmelin) under aquatic condition. *Rept. Dove Mar. Lab.*, Ser. 3, (6), 39-41.
- Dawson, J.W. (1868): The food of the common sea urchin. *Am. Nat.*, **1**, 124-125.
- Deming, W.E. (1943): *Statistical adjustment of data*. Jhon Wiley & Sons, New York.
- Delanuey, H. (1931): L' excretion azotei des invetebres. *Biol. Rev.*, **6**, 265-301.
- Edward, F.R. & Colvin, J. (1952): *Between pacific tides*. 502 pp. Stanford Univ. Press., Stanford.
- Eichelbaum, E. (1910): Ueber Nahrung und Ernährung-sorgane von Echinodermen. *Wiss. Meeres-unters.*, **11**, 187-276.
- Elmherist, R. (1922): Habits of *Echinus esculentus*. *Nature*, **110**, 667.
- Farmanfarmaian, A., Giese, A.C., Booolootian, R.A. & Bennett, J. (1958): Annual reproductive cycle in four species of starfishes. *J. Exp. Zool.*, **138**, 355-368.
- & Phillips, J.H. (1962): Digestion, storage, and translocation of nutrients in the purple sea urchin (*Strongylocentrotus purpuratus*). *Biol. Bull.*, **123**, 105-120.
- Fuji, A. (1960 a): Studies on the biology of the sea urchin. I. Superficial and histological gonadal changes in gametogenic process of two sea urchins, *Strongylocentrotus nudus* and *S. intermedius*. *Bull. Fac. Fish. Hokkaido Univ.*, **11**, 1-14.
- (1960 b): Ditto. II. Size at first maturity and sexuality of two sea urchins, *Strongylocentrotus nudus* and *S. intermedius*. *Ibid.*, **11**, 43-48.
- (1960 c): Ditto. III. Reproductive cycle of two sea urchins, *Strongylocentrotus nudus* and *S. intermedius*, in southern Hokkaido. *Ibid.*, **11**, 49-57.
- (1961): Ditto. IV. Histological observation of the food canal of the sea urchin, *Strongylocentrotus intermedius*. *Ibid.*, **11**, 195-202.
- (1962): Ditto. V. Food consumption of *Strongylocentrotus intermedius*. *Jap. J. Ecol.*, **12**, 181-186.
- Galtosoff, P.S. & Loosanoff, V.L. (1939): Natural history and method of controlling the starfish (*Asterias forbesii* Desor). *U.S. Beu. Fish., Bulletin*, **49**, 76-129.
- Giese, A.C., Krishanaswamy, S., Vasu, B.S. & Lawrence, J. (1964): Reproductive and biochemical studies on a sea urchin, *Stromopneustes voriolaris*, from Madras Harbor. *Comp. Biochem. Physiol.*, **13**, 367-380.
- Greenfield, L., Giese, A.C., Farmanfarmaian, A. & Booolootian, R.A. (1959): Cyclic biochemical changes in several Echinodermen. *J. Exp. Zool.*, **139**, 507-524.
- Hancock, D.A. (1955): The feeding behavior of starfish on Essex oyster beds. *J. Mar. Biol. Assoc.*, **34**, 313-331.
- (1958): Notes on starfish on an Essex oyster beds. *J. Mar. Biol. Assoc.*, **37**, 565-589.
- Harding, J.P. (1949): The use of probability paper for graphical analysis of polymodal frequency distributions. *J. Mar. Biol. Assoc.*, **28**, 141-153.
- Harvey, E.B. (1956): *The american Arbacia and other sea urchins*. 298 pp. Princeton Univ., Press., Princeton.
- Holmes, S.J. (1912): Phototaxis in the sea urchin *Arbacia punctulata*. *J. Anim. Behav.*, **2**, 126-136.
- Huang, H. & Giese, A.C. (1958): Tests for digestion of algal polysaccharides by some marine herbivorous. *Science*, **127**, 475.
- Hunt, O.D. (1925): The food of the bottom fauna of the Plymouth fishing grounds. *J. Mar. Biol. Assoc.*, **13**, 560-599.
- Ino, T. (1943): Feeding and growth of a Japanese Abalone, *Haliotis gigantea discus* REEVE. *Bull. Jap. Soc. Sci. Fish.*, **11**, 171-174. (in Japanese).
- (1953): *Biological studies on the propagation of Japanese abalone (Genus Haliotis)*. 108 pp. Tokai Shobo, Tokyo. (in Japanese).

- Ito, T. (1951): [Statistical methods for relative growth]. 45pp. Kagaku Kyoiku Kenkyu Kai, Tokyo, (in Japanese).
- (1953): Studies on the morphological variation in natural population of *Calanodia copepoda* of Japanese inland waters. *Mem. Mie Pref. Univ.*, **1**, 1-400. (in Japanese).
- Jensen, P.B. (1915): Studies concerning to organic matter of the sea bottom. *Rept. Dan. Biol. Stat.*, **22**, 1-39.
- Kawamura, K. (1960): Some reports on the sea urchin (*Strongylocentrotus intermedius*) in Lake Saroma and on the foreshore in Abashiri. *Hokusuishi Geppo*, **17**, 8-18. (in Japanese).
- & Hayashi, T. (1963): [Ecology of the sea urchin, *Strongylocentrotus intermedius*, in Oshoro Bay, Hokkaido.]. *Annual meeting of Jap. Soc. Sci. Fish.*, Oct., 1963.
- Kawana, T. (1935): [On the propagation of sea urchin]. *Rept. Fukui Fish. Exp. Stat.*, (9). (in Japanese).
- (1938 a): [On the propagation of sea urchin]. *Ibid.*, (11). (in Japanese).
- (1938 b): [On the propagation of *Hemicentrotus pulcherrimus* and the conservation of their resource]. *Suisan Kenkyu Shi*, **33**, 104-116. (in Japanese).
- Kinoshita, T. (1958): [Sea urchin fisheries in Hokkaido]. *Hokusuishi Geppo*, **15**, 1-3. (in Japanese).
- Kubo, I. & Yoshihara, T. (1957): *Suisan Shigen Gaku*. 345pp. Kyoritu Suppan, Tokyo. (in Japanese).
- Kuenzler, E.J. (1961): Structure and energy flow of a mussel population in a Georgia salt marsh. *Limnol. Oceanogr.*, **6**, 191-204.
- Kume, M. (1929): [On the growth of test plates of *Pseudocentrotus depressus*]. *Rigaku Kai*, **27**, 17-21. (in Japanese).
- Lasker, R. & Giese, A.C. (1954): Nutrition of the sea urchin, *Strongylocentrotus purpuratus*. *Biol. Bull.*, **106**, 328-340.
- & Boolootian, R.A. (1960): Digestion of the alga, *Macrocystis pyrifera*, by the sea urchin, *Strongylocentrotus purpuratus*. *Nature*, **188**, 1130.
- Lewis, J.B. (1958): The biology of the tropical sea urchin *Tripneustes esculentus* Lasker in Barbados, British West Indies. *Can. J. Zool.*, **36**, 607-621.
- (1964): Feeding and digestion in the tropical sea urchin *Diadema antillarum* Philippi. *Can. J. Zool.*, **42**, 549-557.
- McPherson, B.F. (1965): Contributions to the biology of the sea urchin *Tripneustes ventricosus*. *Bull. Mar. Sci.*, **15**, 228-244.
- Mielck, W. (1922): Verbreitung und Haufigkeit der Echinodermen auf den Fischgründen in Barentsweer. *Wiss. Meeres-unters.*, **13**, 154-156.
- Millot, N. (1950): The sensitivity to light, reactions to shedding, pigmentation, and color change of the sea urchin, *Diadema antillarum* Philippi. *Biol. Bull.*, **99**, 329-330.
- Minamizawa, A. & Ogawa, Y. (1955): [Effect of artificial rock shelter for the propagation of a sea urchin, *Hemicentrotus pulcherrimus*, in Fukui Prefecture]. *Rept. Fukui Fish. Exp. Stat.*, (20). (in Japanese).
- (1957): Ditto. *Jap. Fish. Agency* (Mimeo.). (in Japanese).
- (1958): Ditto. *Jap. Fish. Agency* (Mimeo.). (in Japanese).
- Moore, H.B. (1934): A comparison of the biology of *Echinus esculentus* in different habitats. Part I. *J. Mar. Biol. Assoc.*, **19**, 869-885.
- & ——— (1935): Ditto. Part II. *Ibid.*, **20**, 109-128.
- & ——— (1936): Ditto. Part III. *Ibid.*, **21**, 711-719.
- , Jutare, T., Bauer, J.C. & Jones, J.A. (1963): The biology of *Lytechinus variegatus*. *Bull. Mar. Sci. Gulf & Caribbean*, **13**, 23-53.
- Nakamura, T. & Yoshinaga, H. (1962): Commercial sea-urchins of the Japan Sea coast of Yamaguchi Prefecture. *Aquiculture*, **9**, 189-200. (in Japan).
- Nataf, G. (1954): Sur la croissance de *Paracentrotus lividus* et des *Psammechinus miliaris* Gmelin. *Bull. Mus. Hist. Nat. Paris*, Ser. 2, **26**, 244-251.

- Oshima, Y., Ishiwatari, N. & Tanaka, J. (1957): Food habits of two species of sea urchins. *Aquiculture*, **5**, 26-30. (in Japanese).
- Parker, G.H. (1932): On certain feeding habits of the sea urchin *Arbacia*. *Am. Nat.*, **6**, 95-96.
- Reeve, E.C.R. (1940): Relative growth in the snout of Anteaters. A study in the application of quantitative methods to systematics. *Proc. Zool. Soc. London*, Ser. A, **110**, 47-80.
- Sakai, S. (1962): Ecological studies on the Abalone, *Haliotis discus HANAI* Ino. I. Experimental studies on the food habits. *Bull. Jap. Soc. Sci. Fish.*, **28**, 766-779. (in Japanese).
- Sang, C. (1963): *Biology of the Japanese common sea cucumber, Stichopus japonicus SELENKA*. 226pp. Kaibundo, Tokyo. (in Japanese).
- Sato, T. (1953): Studies on the growth of the sardine, *Sardinia melanosticta*. *Bull. Jap. Soc. Sci. Fish.*, **18**, 43-52. (in Japanese).
- Scattergood, L.W. (1947): The sea urchin fishery. *Fish. Laef.*, (231).
- Scott, F.H. (1901): Food of the sea urchin (*Strongylocentrotus drobachiensis*). *Contrib. Canad. Biol.*, **1901**, 49-54.
- Shimura, S. (1924): [Gonad development of sea urchin]. *Oita Fish. Exp. Stat.* (in Japanese).
- Shiraishi, Y. (1961): The fisheries biology and population dynamics of pond-smelt, *Hypomesus olidus* (Pallas). *Bull. Freshw. Fish. Res. Lab.*, **10**, 1-263. (in Japanese).
- Stott, F.C. (1931): The spawning of *Echinus esculentus* and some changes in gonad composition. *J. Exp. Biol.*, **8**, 133-150.
- (1955): The food canal of the sea-urchin *Echinus esculentus* L and its functions. *Proc. Zool. Soc. London*, **125**, 63-86.
- Swan, E.E. (1958): Growth and variation in sea urchins of York, Maine. *J. Mar. Res.*, **17**, 505-522.
- (1961): Some observations on the growth rate of sea urchins in the genus *Strongylocentrotus*. *Biol. Bull.*, **120**, 420-427.
- Szymanski, T.S. (1914): Eine Methode zur Untersuchung der Ruhe und Aktivitätsperioden bei Tieren. *Arch. ges. Physiol.*, **158**, 343-385.
- Tennent, D.H., Gardiner, M.S. & Smith, D.E. (1931): A cytological and biochemical study of the ovaries of the sea-urchin *Echinometra lacunata*. *Car. Inst. Wash. Pub.*, (413), 1-46.
- & Ito, T. (1941): A study of the oogenesis of *Mespilia globulus* (Linné). *J. Morph.*, **69**, 347-404.
- Van derHeyde, H.C. (1922): On the physiology of digestion, reproduction and excretion in echinoderms. *Acad. Thesis de Boer. Jr., den Helder*, 111pp. (Cited from Harvey 1956).
- Vevers, H.G. (1949): The biology of *Asterias rubens* L., Growth and reproduction. *J. Mar. Biol. Assoc.*, **28**, 165-187.
- Wesse, A.O. (1925): The food and digestive processes of *Strongylocentrotus drobachiensis*. *Pub. Puget Sound Biol. Stat.*, **5**, 165-179.
- Yamabe, A. (1962): Notes on the culture of the larvae in the sea urchin, *Pseudocentrotus depressus*. *Aquiculture*, **10**, 213-220. (in Japanese).
- Yoshida, M. (1961): Daily rhythmic activity of a land-crab *Sesarma intermedia* (DE HAAN). *Jap. J. Ecol.*, **11**, 160-162. (in Japanese).