



Title	Analysis of Autothermic Reactors
Author(s)	KASHIKI, Isamu; MIKI, Masayuki; SUZUKI, Akira; SAKAI, Makoto
Citation	北海道大學水産學部研究彙報, 30(4), 323-332
Issue Date	1979-11
Doc URL	<a href="http://hdl.handle.net/2115/23702">http://hdl.handle.net/2115/23702</a>
Type	bulletin (article)
File Information	30(4)_P323-332.pdf



[Instructions for use](#)

## Analysis of Autothermic Reactors

Isamu KASHIKI\*, Masayuki MIKI\*, Akira SUZUKI\* and Makoto SAKAI\*

### Abstract

Autothermic reactors equipped with external heat exchangers—two 2-pass reactors (counter-flow and parallel-flow) and two 3-pass reactors (double-pipe and mixed-flow)—are simulated and discussed from viewpoints of stability and optimization.

The 3-pass double-pipe reactor gives maximum conversion when the heat transfer between the inner and the outer pipes vanishes, so it had better be classified as a 2-pass parallel-flow reactor.

With the presence of an external heat exchanger, the stability criterion thus far presented for the autothermic reactor becomes insufficient, and another criterion bases on the relation between the autothermic part and the external heat exchanger which embraces the above criterion should be used.

The 3-pass mixed-flow reactor includes the the two 2-pass reactors as its extreme cases, and can give maximum conversion of the three.

The temperature profile spreads narrowest for the parallel-flow reactor, wider for the counter-flow reactor and the 3-pass reactor, whereas that for the 3-pass reactor is variable.

### Introduction

By an autothermic reactor, that type of catalytic reactors used for exothermic reactions which has heat exchanger(s) within its catalyst bed through which the reactant flows to preheat itself and, at the same time, to level off the temperature profile of the bed, is meant. It is commonly used along with an external heat exchanger which functions to raise the input reactant to a high enough temperature to start the reaction (Figs. 1).

There have been many reports and discussions on autothermic reactors<sup>1,2)</sup>, but none have ever referred to the relationship between the autothermic part and the external heat exchanger notwithstanding they build up a so-called "recycle set" whose mathematical model must be solved simultaneously.

We establish a unique stability criterion for the recycle set, and discuss the behavioral characteristics of the two 2-pass and two 3-pass autothermic reactors from standpoints of conversion and temperature distribution.

### *Problem Definition and Method of Mathematical Treatment*

Four types of the most important autothermic reactors shown in Fig. 1 are dealt with, however, as will be seen later, the 3-pass double-pipe reactor can be coordinated into the 2-pass parallel-flow reactor with respect to optimum performance, and the two 2-pass reactors can be expressed as special cases in the 3-pass

\* *Laboratory of Chemical Engineering, Faculty of Fisheries, Hokkaido University*  
(北海道大学水産学部化学工学講座)

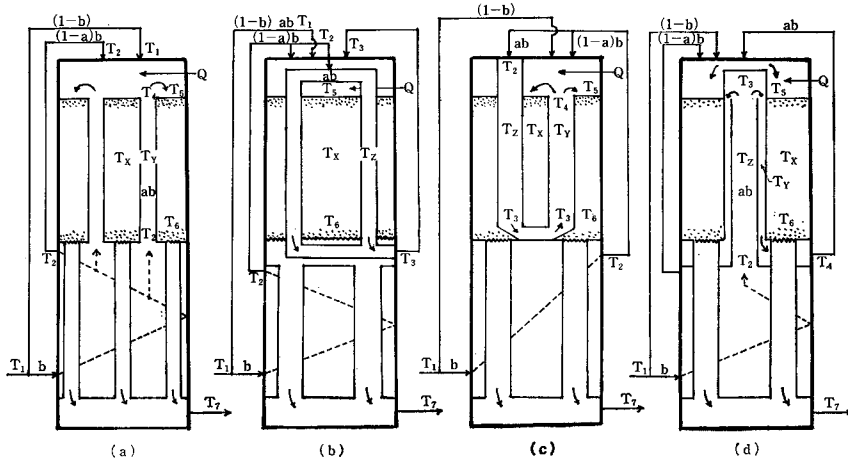

Fig. 1. The schematic classification of the typical autothermic reactors.  
 (a) The 2-pass counter-flow reactor. (b) The 2-pass parallel-flow reactor.  
 (c) The 3-pass mixed-flow reactor. (d) The 3-pass double-pipe reactor.

mixed-flow reactor, the last 3-pass reactor is treated first. For ease of problem solving, several assumptions are made without much loss of generality, as follows:

1. Steady state.
2. Plug flow with no axial heat transfer.
3. No radial heat resistance except at the tube wall and the adjacent films.
4. No heat gain from or loss to the surroundings.
5. Constant specific heat of reacting mass as a whole, irrespective of the composition and/or temperature.
6. Unimolecular exothermic reaction  $A \rightleftharpoons B$ , whose reaction velocity is  $V = k_0 \exp\{-\varepsilon/(\theta + \theta_0)\} C_0 [1 - X - X / \{K_0 \exp(\delta/(\theta + \theta_0))\}]$  occurring.
7. Overall heat transfer coefficients proportional to the 0.75th power of the mass velocities.

(No significant difference results from the assumption of bimolecular reaction as will be described in the following paper.)

Under these assumptions, a following nine simultaneous equations should hold for the 3-pass mixed-flow reactor:

$$\theta_2 = [\gamma / (b + \frac{\gamma}{2} (1-b))] \theta_7 \quad (1)$$

$$\theta_6 = \theta_7 + b\theta_2 (= \Delta X + \theta_Q + b\theta_2) \quad (2)$$

$$\theta_5 = ab\theta_4 + (1-a)b\theta_2 + \theta_Q \quad (3)$$

$$X - X_i = ab(\theta_Z - \theta_Y) + \theta_X - b\theta_2 - \theta_Q \quad (4)$$

$$\Delta X = X_f - X_i = \theta_7 - \theta_Q \quad (5)$$

$$\frac{d\theta_X}{d\lambda} = V' - \beta_1(\theta_X - \theta_Y) - \beta_2(\theta_X - \theta_Z) \quad (6)$$

$$\frac{d\theta_Y}{d\lambda} = -\frac{\beta_1}{ab}(\theta_X - \theta_Y) \quad (7)$$

$$\frac{d\theta_Z}{d\lambda} = \frac{\beta_2}{ab}(\theta_X - \theta_Z) \quad (8)$$

$$V' = \exp\{-\varepsilon/(\theta_0 + \theta_X)\} (1 - X - X/[K_0 \exp\{\delta/(\theta_0 + \theta_X)\}]) \quad (9)$$

where  $V' = V/k_0C_0$

the boundary conditions for (6), (7) and (8) are

$$\begin{aligned} \lambda = 0; \theta_X = \theta_5, \theta_Y = \theta_4, \theta_Z = \theta_2 \\ \lambda = \lambda_0; \theta_X = \theta_6, \theta_Y = \theta_Z = \theta_3 \end{aligned}$$

Notice that somewhat unusual dimensionless variables and parameters are used so that the effect of the catalyst bed length can be demonstrated.

Their solution proceeds as follows:

First assume  $\theta_5$ . Assume  $\theta_2$  and find  $\theta_4$  in virtue of Eq. (4). Calculate  $\theta_X, \theta_Y, \theta_Z$  along  $\lambda$  by the use of some suitable numerical method (Runge-Kutta-Gill method is used here). Apply any shooting method until  $\theta_Y$  equals  $\theta_4$  through varying  $\theta_2$  (the interval halving method is used here.). Use another  $\theta_5$  and repeat the whole procedure. Prepare sets of  $\theta_2, \theta_3, \theta_4, \theta_5, \theta_6, \theta_X, \theta_Y, \theta_Z$  and  $\Delta X$ . Calculate  $\theta_7$  from Eqs. (1) and (2). The set of variables which gives the same value of  $\theta_7$ 's within tolerable error is the solution required.

### *Operational Stability*

As is well known not all the solutions of the above simultaneous equations are operationally stable. By assuming that the catalyst bed maintains invariably the temperature distribution specified by the steady state along the flow, van Heerden<sup>3)</sup> presented a graphical method testing the stability shown diagrammatically in Fig. 2, where the curved line I shows the locus of the solutions of Eqs. (6), (7) and (8) on the  $\theta_4$ - $(\theta_4 - \theta_2)$  plane and implies the heat generation by the reaction, whereas the straight line II denotes the relation among  $\theta_2, \theta_4$  and  $(\theta_4 - \theta_2)$ , and expresses the heat removal by the reactant in the internal heat exchanger. Among their possible intersection(s) designating the solution of the above equations, the steady state consideration determines that points A and C are stable but point B is unstable because the angle between the tangent at the intersection to line I and the abscissa is less for A and C, and greater for B, than the one between line II and the axis.

Another criterion thus far not well known concerns with the relationship between the autothermic part and the external heat exchanger. Thus, in the same figure, the intersection(s) between the curvilinear line I' which denotes the relation between  $\theta_2$  and  $(\theta_6 - \theta_2)$  from the solutions of Eqs. (6), (7) and (8), hence the heat generation by the reaction, and the straight line II' which designates the relation among  $\theta_1, \theta_2$ , and  $(\theta_6 - \theta_2)$  and hence the heat removal by the reactant in the external heat exchanger, and the sign of the angle between the tangent to the line I' at the intersection(s) and the line II', dictate another solution(s) and the stability in such a way as A' and C' are stable but B' is unstable. However, as

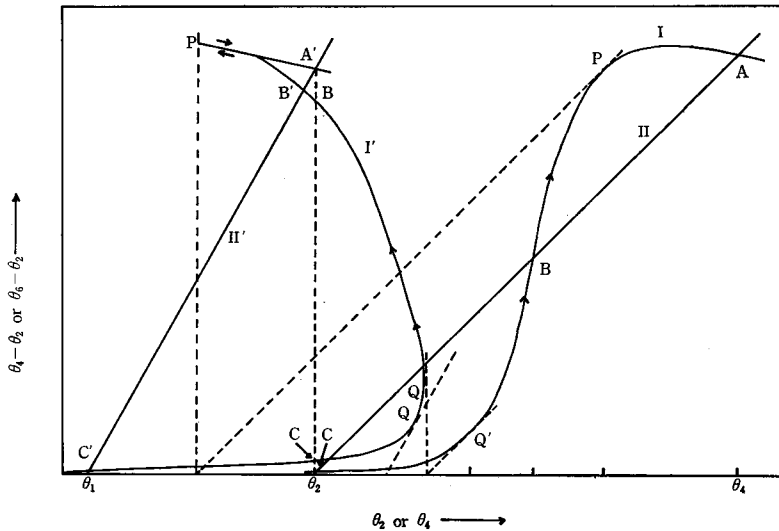

Fig. 2. Two criteria of the autothermic reactor and their relationship. The line I and I' expressed the solution of Eqs. (6), (7) and (8) on the  $\theta_4$ - $(\theta_4 - \theta_2)$  plane and the  $\theta_2$ - $(\theta_6 - \theta_2)$  plane, respectively. The line II has a slope of  $45^\circ$  and is drawn through  $\theta_2$  on the abscissa, and the line II' represents the solution of Eqs. (1) and (2) on the  $\theta_2$ - $(\theta_6 - \theta_2)$  plane.

illustrated in the figure by broken lines, careful examination indicates that the first criterion corresponds to a vertical line in the second criterion which is understandable because no external heat exchanger is present. This clearly shows that the second criterion is more inclusive but nonetheless more restrictive, and hence should be used in commercial reactors which exclusively have external heat exchangers.

*Effect of Heat Transfer in Double Concentric Pipes in the Three-pass Double-pipe Reactor*

Before proceeding further some comment must be made on the performance of the 3-pass double-pipe reactor.

The mathematical model is obtained by substituting Eqs. (6)', (7)' and (8)' written below for Eqs. (6), (7) and (8):

$$\frac{d\theta_X}{d\lambda} = V' - \beta_2(\theta_X - \theta_Y) \tag{6}'$$

$$\frac{d\theta_Y}{d\lambda} = \beta_2(\theta_X - \theta_Y) - \beta_1'(\theta_Y - \theta_Z) \tag{7}'$$

$$\frac{d\theta_Z}{d\lambda} = -\beta_1'(\theta_Y - \theta_Z) \tag{8}'$$

subject to the boundary conditions:

$$\lambda = 0; \theta_X = \theta_5, \theta_Y = \theta_Z = \theta_3$$

$$\lambda = \lambda_0; \theta_x = \theta_6, \theta_y = \theta_4, \theta_z = \theta_2$$

As a matter of course, the stability criterion described above applies to this type of reactor. Kodama et al.<sup>4,5,6,7)</sup> stated that a certain amount of  $\beta_1'$  is favorable based on their mathematical analysis which, for mathematical ease, limited to cases where the chemical reaction rate does not depend upon temperature, or the activation energy is null. Unfortunately no unstable zone exists under their assumption, and the conclusion under practical conditions where the activation energy is considerable and the unstable zone does exist, has been left to scrutiny.

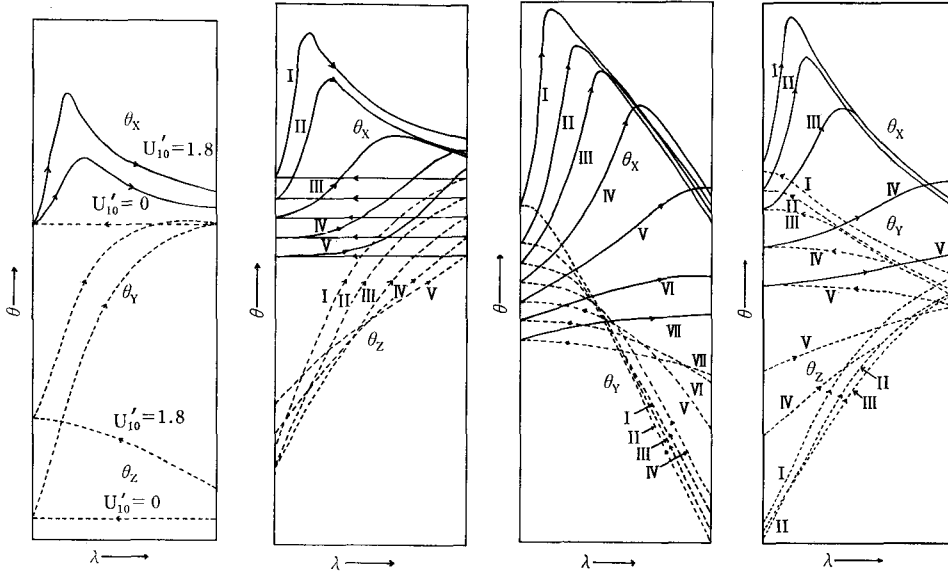

Fig. 3.

Fig. 4.

Fig. 5.

Fig. 6.

Fig. 3. Effect of  $\beta_1'$  on the temperature profile of the 3-pass double-pipe reactor.

$$\beta_1' = U_{1,0}' F^{0.75} S_1' / (k_0 C_0 C_p), U_{1,0}' = 0 \text{ and } 1.8$$

$$\beta_2 = U_{2,0} F^{0.75} S_2 / (k_0 C_0 C_p), U_{2,0} = 7.5$$

For the other parameters, see Table 1.

Fig. 4. Temperature profile of the 2-pass parallel-flow reactor. I at 770°K, II at 760°K, III at 750°K, IV at 740°K and V at 730°K expressed in  $\theta_6$ . Conversion shows max. at 750°K.  $U_{2,0}=10.0, U_{1,0}=0$ . For other parameters, see Table 2.

Fig. 5. Temperature profile of the 2-pass counter-flow reactor. I at 750°K, II at 740°K, III at 730°K, IV at 720°K, V at 710°K, VI at 700°K and VII at 690°K expressed in  $\theta_5$ . Conversion has a max. at 740°K.  $U_{1,0}=8.0, U_{2,0}=0$ . For other parameters, see Table 2.

Fig. 6. Temperature profile of the 3-pass mixed-flow reactor. I at 760°K, II at 750°K, III at 740°K, IV at 720°K and V at 700°K expressed in  $\theta_6$ . Conversion has a max. at 750°K.  $U_{1,0}=U_{2,0}=6.0$ . For other parameters, see Table 2.

The results of the solution of Eqs. (6)', (7)' and (8)' with their boundary conditions disclose that the conversion is at its maximum when  $\beta_1'$  vanishes, at the boundary of the upper stable zone (Fig. 3 and Table 1), in which case the reactor

of this type reduces to a 2-pass parallel-flow reactor. This can be explained at least qualitatively by accepting that the counter-flow heat transfer between the inside and the outside of the inner tube tends to raise  $\theta_3$ , which, in turn, raise  $\theta_6$  and the nearby downstream catalyst temperature, and eventually causes a lower conversion.

Table 1. Maximum conversion (at point P) at various  $\beta_2$  and  $\beta_1'$  values for the 3-pass double-pipe reactor.

Condition:  $C_0=4.44$ ,  $X_i=0.054$ ,  $F=920$ ,  $C_p=10.6344$ ,  $\Delta H=-7,000$ ,  $k_0=0.5 \cdot 10^{-14}$ ,  $E=40,000$ ,  $K_0=0.4735 \cdot 10^{-2}$ ,  $l=5$ ,  $Q=0$ ,  $a=b=0$ ,  $S_2=17.2$ ,  $S_1'=11.5$ ,  $\Delta X$  in %  
 Notice that  $U_2=U_{2,0}F^{0.75}$ ,  $U_1'=U_{1,0}'F^{0.75}$ , and  $\beta_i=U_i S_i/(k_0 C_0 C_p)$

$U_{1,0}'$		$U_{2,0}$			
		7.5	9.0	10.5	13.5
0.0	$T_5=$	760	760	770	770
	$\Delta X=$	25.59	25.40	25.40	25.28
0.25	$T_5=$	760	760	770	770
	$\Delta X=$	25.46	25.51	25.26	25.25
0.50	$T_5=$	760	760	760	770
	$\Delta X=$	25.30	25.51	25.22	25.19
0.75	$T_5=$	750	760	760	770
	$\Delta X=$	25.25	25.45	25.36	25.10
1.0	$T_5=$	750	760	760	770
	$\Delta X=$	25.32	25.32	25.39	24.95
1.4	$T_5=$	750	760	760	760
	$\Delta X=$	25.30	25.11	25.30	25.20
1.8	$T_5=$	750	750	760	760
	$\Delta X=$	25.16	25.28	25.10	25.25
3.3	$T_5=$	740	740	750	750
	$\Delta X=$	25.00	25.00	25.12	25.28

### Behavioral Characteristics of the Autothermic Reactors

When  $\beta_1$  or  $\beta_2$  vanishes in Eqs. (6), (7) and (8), they give the equations for 2-pass parallel-flow or counter-flow reactors, respectively.

The temperature profiles of the two 2-pass reactors and the 3-pass mixed-flow reactor are depicted in Figs. (4), (5) and (6).

There are some general features of particular interest regarding their shapes.

(1) At the boundary of the upper stable zone, P, maximum conversion is attained (Fig. 2),  $\theta_2$  is at its minimum (Figs. 2, 4, 5, 6), and the temperature profiles have negative gradient at the exit of the catalyst bed and shift monotonically upward with a decreased conversion, with the increase in  $\theta_5$  above that point (Figs. 2, 4, 5, 6).

(2) At the boundary of the lower stable zone, Q,  $\theta_2$  is at its local maximum (Fig. 2), and the temperature profile has approximately zero gradient at the bed exit (Figs. 4, 5, 6).

(3) From Q to P along the arrow,  $\theta_2$  tends to fall but with an increased conversion (Fig. 2), and the temperature profile has negative gradient at the bed exit (Figs. 4, 5, 6).

(4) At points below Q,  $\theta_2$  falls off with a decrease in conversion (Fig. 2), and

Table 2. Maximum conversion (at point P) at various  $\beta_1$  and  $\beta_2$  values for the 3-pass mixed-flow reactor.  
 Condition:  $C_0=4.44$ ,  $X_i=0.054$ ,  $F=920$ ,  $C_p=10.6344$ ,  $\Delta H=-7,000$ ,  $k_0=0.5 \cdot 10^{14}$ ,  $E=40,000$ ,  $K_0=0.4735 \cdot 10^{-2}$ ,  $l=5$ ,  $Q=0$ ,  
 $a=b=0$ ,  $S_1=8.6$ ,  $S_2=8.6$ ,  $\Delta X$  in %  
 Notice that  $U_1=U_{1,0}F^{0.75}$ ,  $U_2=U_{2,0}F^{0.75}$ , and  $\beta_i=U_i S_i / (k_0 C_0 C_p)$

$U_{2,0}$		$U_{1,0}$														
		0	1	2	3	4	5	6	7	8	8.5	9	10	11	11.5	12
0	$T_5=$	800	710	710	710	710	720	720	730	730	730	730	730	740	740	740
	$\Delta X=$	20.0	20.18	20.79	21.40	22.41	23.08	23.92	24.64	25.15	25.30	25.38	25.38	25.26	25.17	25.07
2	$T_5=$	370	710	710	720	730		730	740	740		750	750	770		780
	$\Delta X=$	20.85	21.45	22.15	22.99	23.73		25.10	25.54	25.78		25.83	25.77	25.65		25.53
4	$T_5=$	720	720	730	730	740		740	750	750		760	770	780		790
	$\Delta X=$	22.16	22.89	23.60	24.43	24.87		25.81	26.04	26.17		26.18	26.13	26.06		25.99
5	$T_5=$					740	740	750	750		760		770		770	
	$\Delta X=$					25.30	25.72	26.02	26.24		26.33		26.30		26.15	
6	$T_5=$	730	730	740	740	740	750	750	750	760	760	760	770	780		790
	$\Delta X=$	23.49	24.08	24.65	25.19	25.59	25.94	26.22	26.36	26.45	26.47	26.46	26.45	26.42		26.37
7	$T_5=$	730	740	740	740	750	750	750	760	760		760	780			780
	$\Delta X=$	23.96	24.54	25.06	25.42	25.82	26.16	26.33	26.46	26.56		26.57	26.56			26.52
8	$T_5=$	740		740		750	750	760	760		760		770	780	780	780
	$\Delta X=$	24.46		25.24		26.02	26.23	26.40	26.57		26.66		26.69	26.67	26.61	26.66
9.5	$T_5=$			750		750		760	760	760	770		770		780	
	$\Delta X=$			25.65		26.08		26.53	26.65	26.71	26.73		26.81		26.82	
10	$T_5=$	760	750													780
	$\Delta X=$	24.97	25.71													26.86
11	$T_5=$			750		760		760	760	770	770		770	780	780	780
	$\Delta X=$			25.72		26.23		26.56	26.63	26.74	26.79		26.88	26.89	26.91	26.91
12.5	$T_5=$	760		760		760		760	770	770	770		770		780	
	$\Delta X=$	25.32		25.85		26.27		26.46	26.61	26.74	26.79		26.89		26.94	
14	$T_5=$	760		760												780
	$\Delta X=$	25.47		25.93												26.71
15	$T_5=$	760		760		770		770	770	770			770		780	
	$\Delta X=$	25.59		25.90		26.04		26.41	26.54	26.64			26.77		26.87	
17.5	$T_5=$	760		770												780
	$\Delta X=$	25.49		25.67												26.69
18	$T_5=$	760														
	$\Delta X=$	25.40														
21	$T_5=$	770														
	$\Delta X=$	25.40														



the temperature gradient at the exit becomes positive (Figs. 4, 5, 6). Thus  $Q$  is thought to be the minimum permissible condition at which the autothermic part tends to raise its own temperature without resorting to an external heat exchanger, which necessarily functions to give negative temperature gradient at its exit, and with whose presence,  $Q$  shifts to still lower  $Q'$  (Fig. 2).

The above discussion is applicable to the 3-pass double-pipe reactor, although no data are presented.

### Optimization

The 3-pass mixed-flow reactor which embraces the two 2-pass reactors as its extreme cases of  $\beta_1=0$  and  $\beta_2=0$ , is investigated from a viewpoint of maximization of conversion. The results at various  $\beta_1$  and  $\beta_2$  values are summarized in Table 2. All the three reactors exhibit that their maximum conversions are attained at some appropriate values of  $\beta_1$  and  $\beta_2$ , whereas the conversion of the 3-pass reactor is the highest of the three. The reaction trajectories at their maximum conversion on the  $\theta$ - $X$  plane (Fig. 7), disclose that the temperature spreads narrowest along the  $\theta$

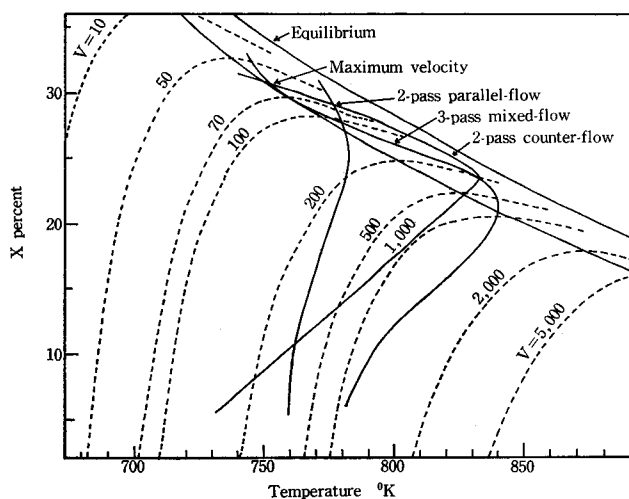

Fig. 7. Reaction trajectories on the  $O$ - $X$  plane optimized with regard to  $\beta_1$ ,  $\beta_2$  and  $\theta_0$ .  $U_{2,0}=15.0$  for the 2-pass parallel-flow reactor,  $U_{1,0}=10.0$  for the 2-pass counter-flow reactor, and  $U_{1,0}=11.5$  and  $U_{2,0}=12.5$  for the 3-pass mixed-flow reactor.

direction for the 2-pass parallel-flow reactor, wider for the 2-pass counter-flow reactor and the 3-pass mixed-flow reactor, while the temperature distribution of the 3-pass reactor is variable by changing  $\beta_1$  and  $\beta_2$  values with no significant loss of conversion.

The effect of various design and operation variables will be discussed in a following paper.

## Nomenclature

- A*: Reactant  
*a*: Fraction of the reactant which enters the internal heat exchanger to that which leaves the external heat exchanger  
*B*: Product  
*b*: Fraction of the reactant which passes through the external heat exchanger to the input reactant  
*C*<sub>0</sub>: Density of the input and the reacting mass at any location in kg-mol/m<sup>3</sup>  
*C*<sub>i</sub>: Concentration of the product in the input in kg-mol/m<sup>3</sup>  
*C*<sub>f</sub>: Concentration of the product in the output in kg-mol/m<sup>3</sup>  
*E*: Energy of activation in kcal/kg-mol  
*F*: Flow rate per unit catalyst cross-sectional area perpendicular to the flow direction in m<sup>3</sup>/m<sup>2</sup>, h  
*ΔH*: Heat of reaction assumed positive for an endothermic reaction in kcal/kg-mol  
*K*<sub>0</sub>: Apparent equilibrium constant at 0°K  
*k*<sub>0</sub>: Preexponential factor of the unimolecular rate constant in h<sup>-1</sup>  
*l*: Distance measured from the inlet of the catalyst bed along the flow in *m*  
*Q*: Heat input from the surroundings per unit catalyst cross-sectional area per unit time at the inlet of the catalyst bed in kcal/m<sup>2</sup>, h  
*R*: Gas constant  
*S*: Heat transfer area per unit cross-sectional area and per unit length of the catalyst bed in m<sup>2</sup>/m<sup>3</sup>  
*S*<sub>1</sub>: *S* between the catalyst bed and the cooling pipe in the counter-flow internal heat exchanger in m<sup>2</sup>/m<sup>3</sup>  
*S*<sub>2</sub>: *S* between the catalyst bed and the cooling pipe in the parallel-flow internal heat exchanger in m<sup>2</sup>/m<sup>3</sup>  
*S*<sub>1</sub>' : *S* between the inner and the outer paths of the double-pipe heat exchanger in m<sup>2</sup>/m<sup>3</sup>  
*S*<sub>x</sub>: Heat transfer area of the external heat exchanger per unit cross-sectional area of the catalyst bed in m<sup>2</sup>/m<sup>2</sup>  
*T*<sub>*i*</sub>: Temperature at point *i* in °K (see Figs. 1, 2, 3, 4)  
*U*<sub>1</sub>: Overall heat transfer coefficient between the catalyst bed and the counter-flow cooling pipe in the internal heat exchanger in kcal/m<sup>2</sup>, h, °K  
*U*<sub>2</sub>: Overall heat transfer coefficient between the catalyst bed and the parallel-flow cooling pipe in the internal heat exchanger in kcal/m<sup>2</sup>, h, °K  
*U*<sub>1</sub>' : Overall heat transfer coefficient between the inner and the outer paths of the double-pipe heat exchanger in kcal/m<sup>2</sup>, h, °K  
*V*: Unimolecular reaction rate in kg-mol/m<sup>3</sup>, h  
*V*' : Dimensionless unimolecular reaction rate  
*X*<sub>*i*</sub>: Initial mole fraction of the product, *C*<sub>*i*</sub>/*C*<sub>0</sub>  
*X*<sub>*f*</sub>: Final mole fraction of the product, *C*<sub>*f*</sub>/*C*<sub>0</sub>  
*ΔX*: Conversion, *X*<sub>*f*</sub> - *X*<sub>*i*</sub>  
*β*<sub>*i*</sub>: Dimensionless heat transfer coefficient, *U*<sub>*i*</sub>*S*<sub>*i*</sub>/(*k*<sub>0</sub>*C*<sub>0</sub>*C*<sub>*p*</sub>)  
*β*<sub>1</sub>' : Dimensionless heat transfer coefficient, *U*<sub>1</sub>'*S*<sub>1</sub>'/(*k*<sub>0</sub>*C*<sub>0</sub>*C*<sub>*p*</sub>)  
*γ*: Dimensionless heat transfer coefficient, *U*<sub>*x*</sub>*S*<sub>*x*</sub>/(*F**C*<sub>0</sub>*C*<sub>*p*</sub>)  
*δ*: Constant, *C*<sub>*p*</sub>/*R*

- $\varepsilon$ : Constant,  $C_p/E/R (-\Delta H)$   
 $\lambda$ : Dimensionless catalyst bed length,  $k_0 l/F$   
 $\theta_i$ : Dimensionless temperature assuming  $T_1=0$ ,  $C_p(T_i-T_1)/(-\Delta H)$   
 $\theta_0$ : Absolute dimensionless temperature corresponding to  $T_1$ ,  $C_p T_1/(-\Delta H)$   
 $\theta_Q$ : Dimensionless temperature rise due to the added heat from outside,  $C_p Q/(-\Delta H)$

### References

- 1) Aris, R. (1969). *Elementary chemical reactor analysis*. Prentice-Hall, 1-352.
- 2) Baddour, R.F., Brian, P.L.T., Logeais, B.A. and Eymery, J.P. (1965). Steady-state simulation of an ammonia synthesis converter. *Chem. Eng. Sci.* **20**, 281-292.
- 3) van Heerden, C. (1953). Autothermic process, properties and reactor design. *Ind. Eng. Chem.* **45**, 1242-1247.
- 4) Kodama, S. and Fukui, K. (1949). On the autothermic reactor. I. Definition and classification. *Ryuan Gijutsu* **2**, No. 2, 31-36.
- 5) Kodama, S. and Fukui, K. (1949). Ditto. II. Temperature distribution. *Ibid.* **2**, No. 2, 37-44.
- 6) Kodama, S. and Fukui, K. (1949). Ditto. III. Design condition under which temperature distributes within narrow range. *Ibid.* **2**, No. 3, 44-47.
- 7) Kodama, S. and Fukui, K. (1950). Ditto. IV. Comparison of counter-flow and parallel-flow internal heat exchangers and significance of the heat transfer in the double-pipe heat exchanger. *Ibid.* **3**, No. 1, 19-25.