



Title	Transmission of Impulses through Abdominal Ganglia in the Crayfish, <i>Cambarus clarkii</i> (With 9 Textfigures and 1 Table)
Author(s)	WATANABE, Yoshio
Citation	北海道大學理學部紀要, 14(1), 17-29
Issue Date	1958-12
Doc URL	http://hdl.handle.net/2115/27282
Type	bulletin (article)
File Information	14(1)_P17-29.pdf



[Instructions for use](#)

Transmission of Impulses through Abdominal Ganglia in the Crayfish, *Cambarus clarkii*^{1, 2)}

By

Yoshio Watanabe

(Zoological Institute, Faculty of Science, Hokkaido University)

(With 9 Textfigures and 1 Table)

The investigation of the physiological function of the nervous system involving sensory and motor mechanism in vertebrates has been successful through the single unit analysis by means of microtechnique by Eccles *et al.* (1953, 1955), and on the other hand by the application of the method of synthetic investigation based on concepts of control engineering (Burns '55, Granit 1952, 1955). Although many fundamental phenomena of the nervous system have been investigated in invertebrates (Bullock 1952, Maynard 1956, Prosser 1946, Wiersma 1952), a few studies have been made based on the above mentioned methods of approach. In the present experiments the author wishes to analyse with the aid of modern techniques the transmission of the impulse through an isolated abdominal ganglion in a crayfish (*Cambarus clarkii*).

Crustacea offer an advantage in that it is easy to remove the central nervous system from the exoskeleton, but it is difficult to discriminate afferent axons from efferent ones anatomically. A nerve map of transmission routes was made up at first by stimulation tests and recording of action potentials. Then the various forms of transmission were observed by extracellular recording, and comparison was made with the intracellular recording from a single nerve cell in the ganglion.

Material and Methods

The ventral nerve cord, which was removed from the abdomen of the crayfish, *Cambarus clarkii*, was placed in a plastic chamber filled with Harrevel'd's solution³⁾. In the operative removal of the ventral nerve cord, the segmental nerves branched off from each ganglion were left attached as long as possible, for convenience of stimulation and recording.

Stimulation was applied by a pair of fine Ag-AgCl electrodes, on which the afferent nerve fibers were hooked and raised in the air above the medium (Fig. 1). In extracellular recording, transmitted impulses through the ganglion were picked up with similar electrodes

1) Contribution No. 426 from the Zoological Institute, Faculty of Science, Hokkaido University, Sapporo, Japan.

2) The preliminary report was published in Proc. Vith Ann. Meet. Japan E.E.G. Soc., 1957. pp. 34-35 (Suppl. Vol. of Folia Psychiat. Neurolog. Japan.).

3) NaCl : 1.2%, KCl : 0.04%, CaCl₂ : 0.15%, MgCl₂ : 0.02%, H₂O : 98.59%, pH : 7.4.

Jour. Fac. Sci. Hokkaido Univ. Ser. VI, Zool., 14, 1958.

from an isolated single efferent axon. Glass capillary microelectrodes used in intracellular recording has to possess an electrical resistance of about 10 Mohms when they were filled with 3M-KCl, for such a microelectrode gave no damage to the cell body and did not deteriorate the frequency characteristic in input stage of the amplifier. The microelectrode was inserted into the neurone by a micromanipulator under a binocular microscope.

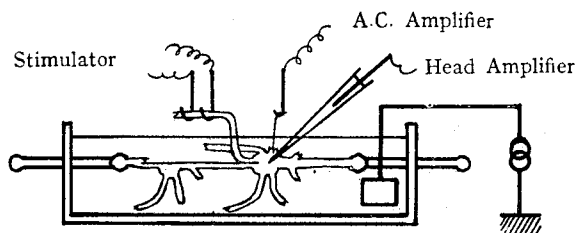

Fig. 1. Diagram of the specimen chamber with recording and stimulating electrodes system. The preparation is suspended in a chamber built of plastic and filled with Harreveld's solution.

For the extracellular record, a resistance-capacity coupled amplifier with time constant of 20 msec. was used, and for the intracellular record, a head amplifier connected to a direct coupled amplifier of balanced type. The head amplifier was early of the cathode follower type, but later in the most part of these experiments it was changed for an ordinary negative feedback amplifier accompanied with a negative impedance circuit (see the appendix). This new head amplifier had the rising time constant of 0.05 msec. for the input impedance of 10 Mohms. After amplification, potential changes were fed to a cathode-ray tube, 3KP11, through an electronic switch of 50 Kcycle for dual sweep to record simultaneously both action potentials and stimulation signals. In a part of the intracellular recording, the dual beam cathode-ray oscilloscope (Nihon Kodan) was also used. All experiments were carried out at room temperature 13°C–22°C.

Results

Nerve map and transmission routes The crayfish have six abdominal ganglia in the ventral nerve cord. Excepting the 6th caudal ganglion, the others have a similar structure; they branch off three pairs of segmental nerve trunks (Fig. 2). A pair of them, *Nervus pedis spurii*, innervates several muscles, hypoderm and pleura of an abdominal appendage. The second pair, *Nervus dorsolaterales*, goes to various muscles and hypoderm of the abdomen. Thus these trunks are comprised of various sensory and motor axons. The third pair, *Nervus ventralis*, have several motor giant axons innervated on several muscles, but have no sensory axons. The results of observations are almost the same as those described by Hanström (1928).

It was possible to distinguish between afferent and efferent axons by examination of direction of impulses transmitted through the ganglion. In this

case, the transmitted impulses occasionally occurred on a background of spontaneous activity, the rhythmic impulses which are conducted to the distal part without any stimulus from the outside. The spontaneous activities were recorded from some axons in the segmental trunks. Such axons were surely efferent, but the spontaneous activity was not always recorded from every efferent axon. In motor giant axons in *Nervus ventralis* the spontaneous activity was never observed. The extracellular record of spontaneous activity in a segmental trunk was represented by impulses of various amplitudes at irregular frequency and had a characteristic feature for each nerve trunk.

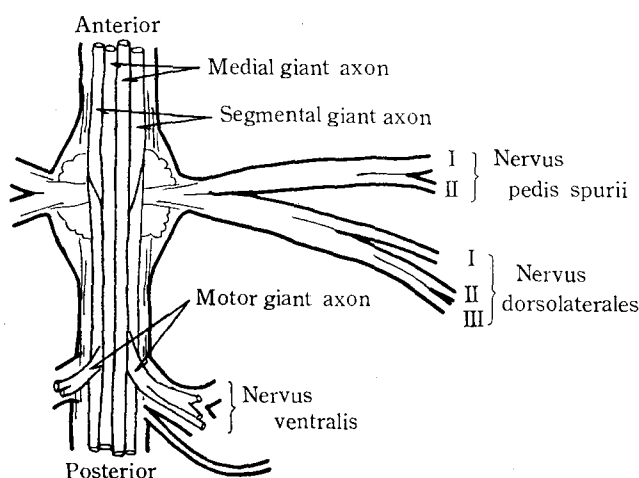

Fig. 2. Dorsal view of a part of the ventral cord of the crayfish in which there is an abdominal ganglion accompanied with the segmental nerves.

When a segmental nerve trunk was stimulated, some responses occurred in several regions through the various routes in the ganglion. These responses were due either directly to transmission of impulses or indirectly to inhibition of the spontaneous activity. Relations between routes and recorded responses are shown in Table 1. The transmission of impulses from N.d. -III to itself means the reflex impulses from afferent axons to efferent axons in this segmental trunk. Stimulation of the ventral cord was applied to the separated axon bundle, which included only several axons in the nerve cord. The system of giant axons is a peculiar feature in the nervous system of the crayfish; two medial giant axons run through the ventral cord in the core, and along them there are segmental giant axons connected to the segmental ganglions one after another and joined with motor giant axons of the contralateral side in each ganglion (Fig. 2). Actually the transmission into *N. ventralis* (motor giant axons) occurred only when a segmental

Table 1. Routes of transmission through the abdominal ganglion. Rows are the stimulating nerves and columns are the recording nerves, respectively. For abbreviations of nerve names see Fig. 2. T: transmission of impulses. I: inhibition of spontaneous discharges. *: no response.

Ss.	V. C.	N. p. -I	N. p. -II	N. d. -I	N. d. -II	N. d. -III	N. v.
V. C.	T, I	T	T	T	T	T	*
N. p. -I	T		I	*	*	*	*
N. p. -II	T	I		*	*	*	*
N. d. -I	*	*	*	*	*	*	*
N. d. -II	*	*	*	*	*	*	*
N. d. -III	T, I	*	*	*	*	T	*
N. v.	T	*	*	*	*	*	

giant axon of contralateral side in the ventral cord was stimulated.

Temporal pattern of the transmitted impulse sequence The stimulation used throughout these experiments was rectangular pulse trains of various frequencies, 25-200 per sec. The pulse frequency of each train was kept constant. Impulses of the preganglionic axon gave rise always without any effect of refractoriness to stimulation of a frequency less than about 200 per sec.

The temporal patterns of impulse sequences transmitted through the ganglion to the postganglionic axon on application of such stimulation could be roughly divided into three types. There was a type in which the frequency of postganglionic impulses always coincided with that of rectangular pulses sent to the preganglionic axon. The time delay from stimulation to postganglionic impulse signal in transmission of this type was within 1-2 msec. In Fig. 3 a

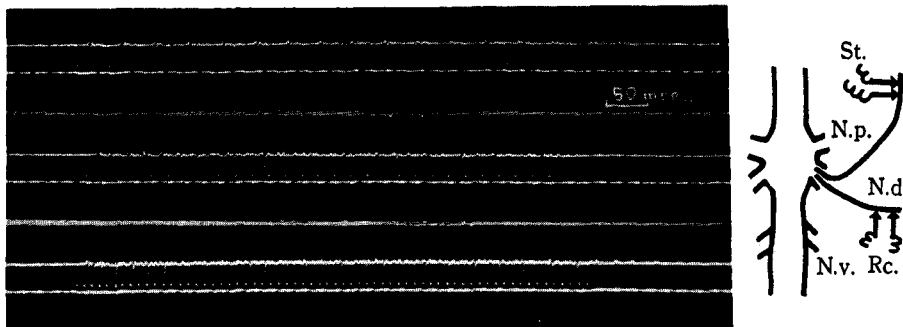

Fig. 3. Temporal patterns of the 2nd type of ganglionic transmission in response to various frequencies of stimulation. Upper signal is transmitted impulses and lower signal is stimuli, in each record. Figure at the right side of record shows the places of stimulating and recording electrodes. St.: stimulating electrodes. Rc.: recording electrodes. N.p.: *Nervus pedis spurii*. N.d.: *Nervus dorsolaterales*. N.v.: *Nervus ventralis*.

typical feature of the 2nd type is shown. The postganglionic impulses occur after 5–10 msec. from the preganglionic stimulation. They occur initially with higher frequency than that of stimulation but with decreasing frequency down to 40–70 per second in the form of exponential decay with a time constant of about 20 msec. In the later period of the time course the frequency of the post-ganglionic impulses fluctuates slightly or occasionally is uniform but it is lower than that of stimulation, therefore, the transmitted impulses through a ganglion do not always follow the preganglionic impulses. The initial frequency of postganglionic response depends closely upon the stimulation frequency of preganglionic nerve up to about 150 per sec. (see Fig. 4) but it is yet lower than the highest frequency (200–250 per sec.) at which the axon can be made to respond without any refractoriness. In stimula-

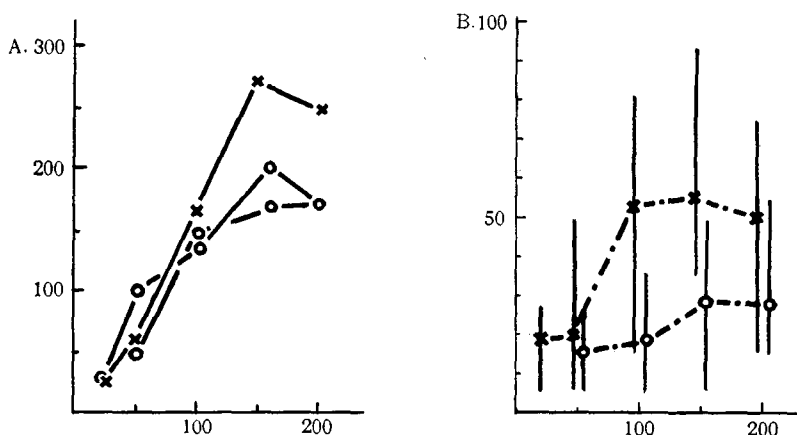

Fig. 4. Relationships between the frequencies of afferent impulses and those of efferent ones in the 2nd type of ganglionic transmission. X and O represent the experimental series of two different experiments respectively. *Abscissae*: stimuli per second. *Ordinates*: efferent impulses per second.

A. Frequency relations of the early period in responses to stimuli.

B. Frequency relations of the later period in responses to stimuli with deviation ranges of the ordinates.

tion at lower frequency than about 50 per sec., there were some cases in which this type was confusable with the 1st type, for absence of the decreasing phase in the temporal pattern of impulse frequency (Fig. 3A). However it was possible to distinguish the 2nd type from the 1st type by the difference of time required for transmission: the time was 5–10 msec. in the former, it was much longer than that in the latter (1–2 msec.).

The particular features of the 3rd type of the transmission through a ganglion are the presence of an increasing phase in the transmitted impulse sequence

and that of a remarkable after-burst. In addition the time delay required for beginning transmission of this type was occasionally longer than the other types (Fig. 5). Fig. 5A shows that the output efferent frequencies are hardly dependent upon the input afferent frequencies, and Fig. 5B that the efferent impulses arise completely independent of the stimulation of the afferent nerve at the three employed frequencies.

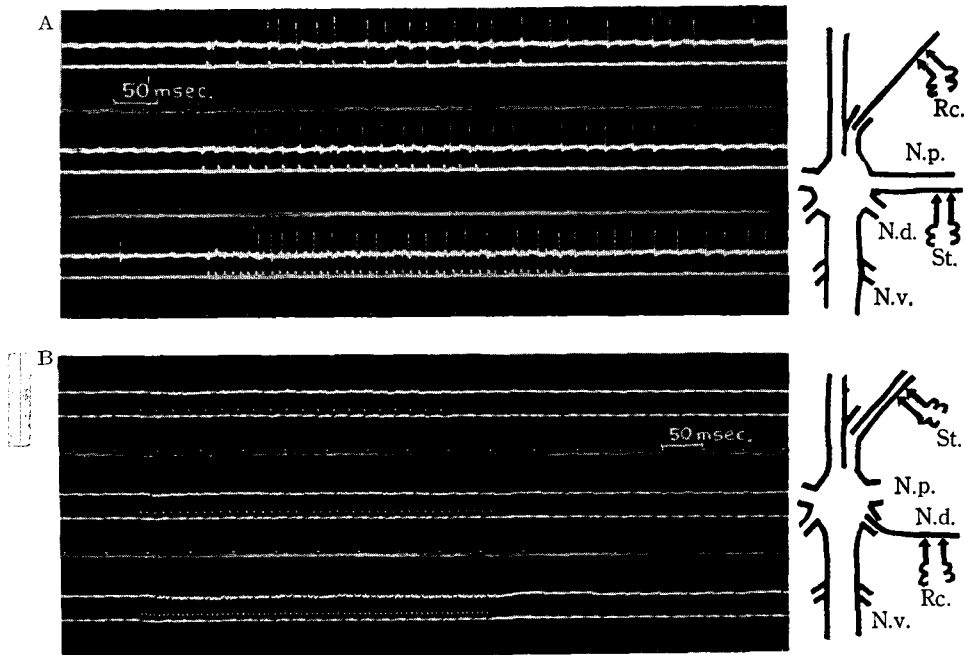

Fig. 5. Temporal patterns of the 3rd type of ganglionic transmission in response to stimuli of various frequencies.

A. Transmission from *N. pedis spurii* to an axon in the ventral cord.

B. Transmission from several axons in the ventral cord to a single axon in *N. dorsolaterales*.

Each type of transmission of the above three occurred usually in a particular route respectively: the 1st type was seen in the route from the ventral cord to N.d.-III in Table 1; the 2nd type, in the route from N.d.-III to itself reflexing ipsilaterally, and the 3rd type, in the route from N.p.-I, II to the ventral cord. However the three transmission types were observed in a route such as that from the ventral cord to N.d.-III, being determined by the combination of various pre- and postganglionic axons in the route.

Besides the increase in the frequency of stimulation, increase both in

amplitude of individual pulse of stimulation and in number of axons in preganglionic nerve bundle stimulated produced a rise in frequency of the transmitted impulse in the postganglionic nerve to a maximum.

Intracellular recording of synaptic response In order to observe directly the process of transmission of an impulse through the single ganglionic cell, an intracellular recording was made. Stimuli were applied to the segmental nerve trunk, in most cases *N. pedis spurii*, and the electrical potential changes were recorded from the basal part of this trunk (Fig. 6H). As the microelectrode was inserted into the ganglion, small potential changes resulting from an unknown source were frequently observed. The entry of the microelectrode into a nerve cell was immediately signaled in the record by the development of the resting membrane potential, 50–60 mV inside negative. The electrode was not always inserted into the neurone soma, in some cases it was inserted into the axon. The resting membrane potentials of the axon ranged 70 to 90mV, and such a potential was deeper than that of the soma. It was possible to distinguish the spikes of an axon from that of soma by their size and the time course both in their rising and in their falling phase.

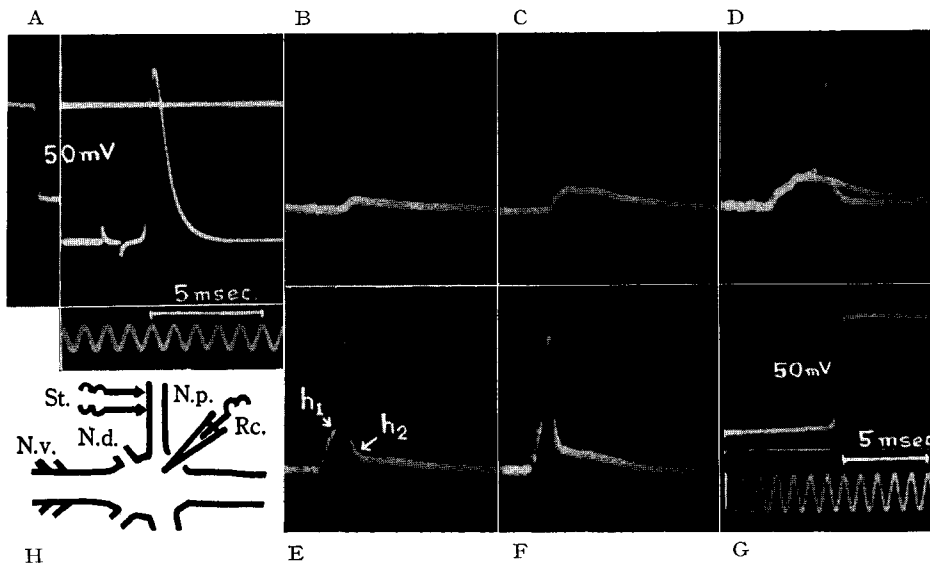

Fig. 6. Action potentials of a neurone recorded with an intracellular microelectrode.

A. A spike potential of the axon. The preceding signal is the stimulus artifact.

B-F. The action potentials of the neurone soma. The preceding signal in each record is the stimulus artifact. In E, h_1 and h_2 indicate an inflecting point at the rise of post synaptic spike from the synaptic potential and another inflecting point at the fall of it to the synaptic potential respectively ($h_1 = h_2 + 15$ mV). (Cf. the text).

The synaptic response was composed of a small and slow depolarization (the synaptic potential) and a spike which was similar to the axon spike but smaller than it (Fig. 6D-F). The synaptic potentials were not always uniform but they ranged 0 to 20 mV in height and 20 to 50 msec. in duration. The synaptic potential was caused to grow up to a critical size by the increase in stimulus strength applied to the afferent axons. The post synaptic spike set up by the synaptic potential exceeded the critical size (J.C. Eccles, '53, '55). In case the postsynaptic spike was set up, the increase in stimulus strength resulted in shortening of the interval between time of rise of the synaptic potential and that of the postsynaptic spike, and it resulted also in raising of the height of synaptic potential at which the postsynaptic spike was evoked. A typical record to the synaptic response (Fig. 6) shows the presence of two inflecting points of action potential, i.e. h_1 at the rise of postsynaptic spike from the synaptic potential and h_2 at the fall of it to the synaptic potential. The former point is always at a higher level of depolarization (constantly as much as about 15 mV) than the latter one. The difference of height between the two points of inflection may be explained as due to suppression of the synaptic potential by the hyperpolarization after the spike (Fig. 6-D, E and F).

Repetitive synaptic response An example of intracellular recording of synaptic response to repetitive stimulation is shown in Fig. 7. Although this transmission is closely similar to the 2nd type of ganglionic transmission, it differs there from with respect of the presence of the initial high frequency response to the stimulation of low frequency. This phenomenon was occasionally observed in the fresh preparation, but it disappeared after too frequent stimulation of the same route.

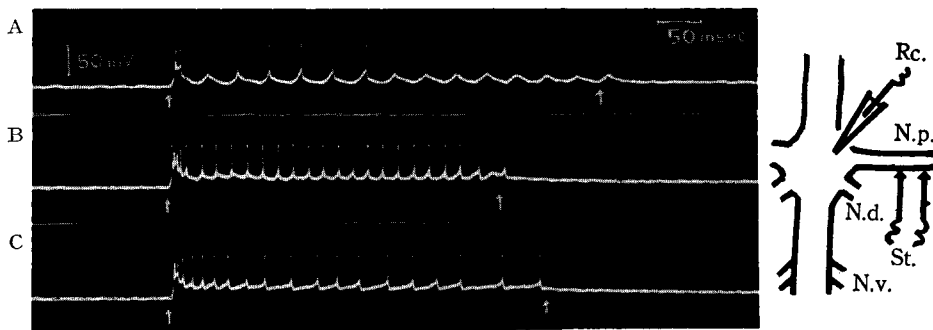

Fig. 7. Intracellularly recorded trains of responses of a neurone some to stimuli of various frequencies. Stimulation frequencies are 25 per sec. in A, 50 per sec. in B, and 100 per sec. in C respectively. Arrows indicate the time when the stimulation was begun and finished.

During the stimulation at low frequency (25 or 50 per sec.) the synaptic potential appeared in response to each pulse of the stimulation, although it was not

always accompanied by the post-synaptic spike (Fig. 7 A, B). The synaptic potentials gradually decay with time and the spikes disappear according to decay of the former below a critical level, as is shown in Fig. 6. After the initial response of high frequency the spikes were apt to disappear owing to the suppression of the synaptic potential by the after potential of the previous spikes (Fig. 7A). On stimulation at a high frequency (100 per sec.) the temporal summation of synaptic potentials occurred and a continuous depolarization of the ganglionic cell membrane was produced (Fig. 7C). The post-synaptic spikes set up by the continuous depolarization do not follow the stimulating pulses but the frequency of them decreases according to gradual decrease in the degree of depolarization. The two lines in Fig. 8A represent the relations of the spike frequency and the depolarization level at which the post-synaptic spike is evoked, respectively to the depolarization suppressed by the after potential. Since the synaptic potential can not directly be seen owing to the evocation of the spikes in direct succession, the

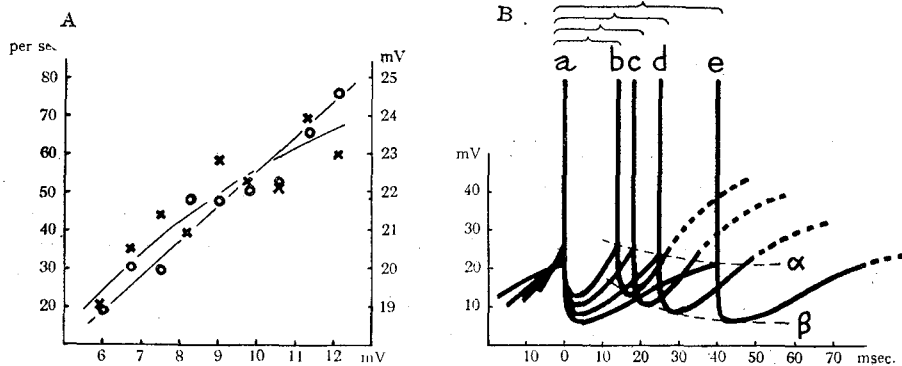

Fig. 8. Relationship between the frequency of efferent impulses and the height of the synaptic potential.

A. Relations of the frequency of efferent impulses (○) and the depolarization level (×) at which the spike is evoked, to the synaptic potential suppressed by the after potential of the spike. Abscissae; the depth voltages from the resting level to the after potential. Ordinates on the left: the frequency of efferent impulses. Ordinates on the right: depolarization level at which the post-synaptic spike is evoked.

B. Schema illustrating the mechanism for determining the interval between the postsynaptic spikes. Abscissae: times in milliseconds. Ordinates: voltages from the resting level of the membrane potential. Spikes a-b, a-c, a-d, and a-e show the time courses of two (the initial and next b, or c, or e) spikes at intervals of 14 msec., 18 msec., 25 msec. and 40 msec. respectively. The broken line α shows the manner of change in the depolarization level at which the post-synaptic spike is evoked, and β the manner of change in the depolarization suppressed by the after potential of spike e.

depolarization suppressed by the after potential was used as an indication of the height of the synaptic potential (Fig. 8B, line β). The spike frequency depends obviously upon the height of this suppressed depolarization (Fig. 8A). On the other hand, the level of the initial depolarization (Fig. 8B, line α) at which the spike was evoked rose with the level of suppressed depolarization (Fig. 8B, line β). It has already been seen in Fig. 6 that the critical level (h_1) at which the spike was set up rose with the synaptic potential (h_2).

Fig. 8B is a scheme which represents the relation of the spike interval to the synaptic potential and the after potential of the spike, drawn from the relations in Fig. 8A. The rising rate in recovering process from the after potential and the suppressed depolarization may increase with the synaptic potential height, as suggested by the dotted lines which extrapolate the after potentials in Fig. 8B. The increase of the rising rate from the after potential results in the shortening of intervals between spikes. On the other hand, the elevation of the critical level of the spike evocation inhibits the increase in the spike frequency. Owing to this effect, in spite of the diminution of the synaptic potential, the post-synaptic spikes occur in response to the stimuli at low frequency, until the spikes disappear after the extreme diminution of the synaptic potential.

Discussion

The routes in which the 1st type of ganglionic transmission occurred have surely no connection with any synapse, because the time required for the transmission was always smaller than the synaptic delay observed in intracellular recording and it was equal to a time required for conduction and latency of only the axon itself.

The time delay of the 2nd type of transmission was longer than the synaptic delay, and occasionally reached to 10msec. The temporal pattern of the efferent impulse sequence in this transmission type may be determined by the time course of the continued depolarization of the ganglionic cell membrane caused by the temporal summation of the repetitive synaptic potentials. The determination of the pattern differs between the low frequency stimulation at which the individual synaptic potentials are separated and the high frequency stimulation at which the temporal summation of the synaptic potential occurs. In the former case, each efferent impulse always appears in response to each individual stimulus. In the latter case, no closer coordination between each efferent impulse and stimulus is seen, although the frequency of efferent impulses depends upon the frequency of stimulation. The interval of efferent impulses may be determined by the competitive condition between the after potential of the spike and the synaptic potential. Besides the above described results a periodic change in frequency of the 2nd type transmission was observed; it may be due to a periodic change in the condition of the competitive action. The 2nd type of transmission probably occurs in the routes connected by a few synapses; it is best suggested by the time delay of transmission.

There were further various cases in the ganglionic transmission classified into the 3rd type. The response of the routes in which the 3rd type occurred was not always in the same way as in the previous trial, even if the experimental

conditions were identical. The uncertainty of the 3rd type may be concerned with the occurrence of some other spontaneous activity, the effect of inhibition or the complexity of the transmission path in these routes (Maynard 1955).

The temporal pattern of the post-synaptic spikes recorded intracellularly is not to be restricted within the 2nd type, for it is impossible to anticipate the route connected with the particular nerve cell into which the microelectrode was inserted. However, the intracellular records from these experiments were of the 2nd type only, presumably because the stimuli were given at the same position in the nervous system every time.

Summary

1. The action potentials set up in the postganglionic nerve by the pre-ganglionic volleys were observed in the isolated abdominal ganglion of the crayfish. A nerve map of the transmission routes was made up on the basis of both by microscopic observation and by recording of action potentials with various combinations of axon routes.

2. The temporal patterns of impulse sequences transmitted through the ganglion were divided into the following three types: 1) the 1st type in which the efferent impulses occurred in the form of one to one correspondence with the afferent impulses throughout; 2) the 2nd one in which the frequency of the efferent impulses decreased gradually; 3) the 3rd one in which the frequency of post-synaptic impulses decreased or increased and sometimes an after-burst occurred directly after the stoppage of stimulation.

3. The frequency of the initial response of the 2nd type transmission was proportional to the stimulation frequency in the range of 50–150 per sec. and it was usually higher than the stimulation frequency.

4. The synaptic potentials were observed by intracellular recording. The height of synaptic potentials depended upon the strength of the preganglionic stimulation and was in the range of 10–20 mV. A post-synaptic spike was evoked when the depolarization owing to the synaptic potential reached a critical level of about 20 mV.

5. A temporal summation of the synaptic potentials occurred as a result of repetitive stimulation. The temporal pattern of the efferent impulse sequence depended upon the time course of continued depolarization owing to the temporal summation of synaptic potentials. In other words, the interval of post-synaptic spikes was determined by a competitive action between the synaptic potential and the after potential of the previous spike.

The author wishes to express his cordial thanks to Professor. Mituo Tamagishi for his kind guidance and encouragement throughout the course of this work and also for improvement of the manuscript.

Literature

- Bullock, T.H. 1952. The invertebrate neuron junction. Cold Spring Hrbr. Symp. Quant. Biol. 17 : 267-273.
- Burns, B.D. 1955. The mechanism of after-burst in cerebral cortex. J. Physiol. 127 : 168-188.
- Coomb, J.S., J.C. Eccles and P. Fatt 1955. Excitatory synaptic action in moto-neurones. J. Physiol. 130 : 374-356.
- Eccles, J.C. 1953. Neurophysiological Basis of Mind. Oxford.
- Granit, R. 1955. Receptors and Sensory Perception. Yale Univ. Pr.
- Granit, R., B. Holmgren and P. A. Merton 1955. The two routes for excitation of muscle and their subservience to the cerebellum. J. Physiol. 130 : 213-224.
- Hanström, B. 1928. Vergleichende Anatomie des Nervensystem der wirbellosen Tiere. Springer.
- Maynard, D.M. 1955. Activity in a crustacean ganglion. II. Pattern and interaction in burst formation. Biol. Bull. 109 : 420-436.
- Prosser, C.L. 1946. Action potential in the nervous system of the crayfish. Effects of drugs and salts upon synaptic transmission. J. Cell. and Comp. Physiol. 16 : 25.
- Wiersma, C.A.G. 1952. Repetitive discharge of motor fibers caused by a single impulse in giant fibers of the crayfish. J. Cell. and Comp. Physiol. 40 : 399-420.

Appendix

A head amplifier for intracellular recording

In intracellular recording with a glass capillary microelectrode filled with 3M-KCl, it is desirable that the grid current and the input capacity at the 1st stage of amplifier be as small as possible. The cathode follower is available for this purpose. To reduce the input capacity, i.e., to increase the input impedance, in this type, it is necessary to make the tube act in high cross conductance and cathode load. On the other hand, to reduce the grid current the plate current must be sufficiently small. Consequently such a high cross conductance can not be expected. It can be covered by means of a multistage amplifier in which the 1st stage tube is used to reduce the grid current and signals are fed back negatively to the 1st stage through the latter high gain stages.

The capacity (ca. 1pF/mm) between the capillary microelectrode and the surrounding medium causes a distortion of the component of high frequency response. This disturbance can be eliminated by addition of a negative impedance circuit, i.e. a positive feed back circuit of high frequency components of the signal.

The head amplifier schematically shown in Fig. 9, was successfully made to fit the above purpose. Low plate and heater voltages were applied to the 1st stage tube, 1T4, to reduce the grid current. Signals were amplified by a D.C. amplifier of two 12AX7 in the next stage and fed back negatively to the cathode of 1T4 and positively to the grid of the same tube through the microelectrode lead shield. In this equipment, the grid current was reduced within 10^{-10} Amp. and the rise of the step input had a time constant of 30 microseconds with the input electrode resistance of about 20 Mohm. In the present work only 1T4 was used as the 1st stage tube. It may be better to use the tube, 1620, 6AU6 or EF86 than it.

It is reported that input capacity of the usual cathode follower is about 10pF (J. W. Woodbury, '52).¹⁾ In order to obtain less distortive records of the action potential

rising in 0.15–0.2 msec., it is impossible to use an electrode of which the resistance is higher than 5 Mohm. The electrical activity of the ganglionic cell can not constantly be recorded when the electrode resistance is lower than 10 Mohm, because the diameter of tip of the electrode is too large to be safely inserted into the cell. The input time constant of such head amplifier reaches 200 microseconds for the microelectrode of 20 Mohm. Nastuk and Hodgkin ('50) got the input time constant of 75 microseconds by a cathode follower input stage with a microelectrode lead shield connected to the cathode, and Woodbury ('52) that of 35 microseconds by means of a positive feedback compensation. In the present equipment, a similar characteristic to theirs has been easily obtainable.

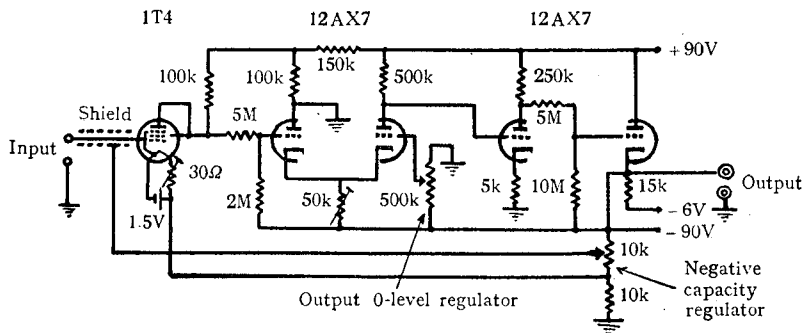

Fig. 9

1) Woodbury, J.W. 1952. Direct membrane resting and action potentials from single myelinated nerve fibers. *J. Cell. Comp. Physiol.* 39: 323–339.