



<b>Title</b>	Cascadable current-mode filters using CDTAs
<b>Author(s)</b>	Pongpisal, Tanin; Unhavanich, Sumalee; Tangsrirat, Worapong; Surakamponorn, Wanlop
<b>Citation</b>	Proceedings : APSIPA ASC 2009 : Asia-Pacific Signal and Information Processing Association, 2009 Annual Summit and Conference, 303-306
<b>Issue Date</b>	2009-10-04
<b>Doc URL</b>	<a href="http://hdl.handle.net/2115/39697">http://hdl.handle.net/2115/39697</a>
<b>Type</b>	proceedings
<b>Note</b>	APSIPA ASC 2009: Asia-Pacific Signal and Information Processing Association, 2009 Annual Summit and Conference. 4-7 October 2009. Sapporo, Japan. Poster session: Advanced Circuits and Systems/VLSI (5 October 2009).
<b>File Information</b>	MP-P3-7.pdf



[Instructions for use](#)

# Cascadable current-mode filters using CDTAs

Tanin Pongpisal\* Sumalee Unhavanich\*\* Worapong Tangsrirat\* Wanlop Surakampontrorn\*

\*Faculty of Engineering,  
King Mongkut's Institute of Technology Ladkrabang (KMITL),  
Ladkrabang, Bangkok 10520, THAILAND  
E-mail: dasa\_kmitl@hotmail.com, ktworapo@kmitl.ac.th, Tel/Fax: +66-2-326-4205

\*\*Faculty of Engineering,  
King Mongkut's University of Technology North-Bangkok (KMUTNB),  
Bangsue, Bangkok 10800, THAILAND

**Abstract**— In this paper, a variety of cascadable current-mode filter architectures incorporating current differencing transconductance amplifiers (CDTAs) and grounded passive elements are realized. The proposed filter topologies mainly contain the CDTA-based cascaded filter structure and the current feedback loop, which provides a systematic and structural method for realizing general filtering functions. They are convenient for integration, electronically tunable, easy cascadability, of low sensitivity, simple in structure and easy to design. Design examples and simulation results by PSPICE confirm the usefulness of the proposed approach.

## I. INTRODUCTION

Recently, a new current-mode active building block, which is called as a current differencing transconductance amplifier (CDTA), has been introduced in [1]. This device that has two current inputs and two kinds of current output provides an easy implementation of current-mode active filters [2]. It also exhibits the ability of electronic tuning by the help of its transconductance gain ( $g_m$ ). All these advantages together with its current-mode operation nature make the CDTA a promising choice for realizing the current-mode filters. As a result, several realizations of current-mode filters using CDTAs as active elements have been developed in the literature [1]-[5]. However, the systematic method for realizing CDTA-based cascadable current-mode filtering structures has not yet been proposed and studied sufficiently. To allow an easy cascadability in current-mode, an active filter should theoretically exhibit both low-input and high-output impedances.

Therefore, this paper largely focuses on presenting structural generations to synthesis the cascadable current-mode filters employing CDTAs. The proposed filter structures consist of CDTAs in cascade connection and the current feedback paths, which can realize the general filter functions, i.e., lowpass (LP), bandpass (BP), highpass (HP), and bandstop (BS). The obtained filter characteristics, such as the natural frequency ( $\omega_0$ ) and the quality factor ( $Q$ -factor), can be electronically tuned through biasing current of the transconductance gain of the CDTAs. All the proposed filter architectures contain only grounded passive components, which can absorb parasitic elements and require smaller chip area than floating ones [6]-[7]. Additionally, the filters possess both low-input and high-output impedance levels, which will be more convenient in terms of cascading and connecting to other stages.

## II. CURRENT DIFFERENCING TRANSCONDUCTANCE AMPLIFIER (CDTA)

The circuit representation and the equivalent circuit of the CDTA are shown in Fig.1. The terminal relation of the CDTA can be characterized by the following set of equations [1].

$$v_p = v_n = 0, \quad i_z = i_p - i_n \quad \text{and} \quad i_x = g_m v_z = g_m Z_z i_z \quad (1)$$

where p and n are input terminals, z and x are output terminals,  $g_m$  is the transconductance gain, and  $Z_z$  is an external impedance connected at the terminal z. According to above equation and equivalent circuit of Fig.1(b), the current through the terminal z follows the difference of the currents through the terminals p and n ( $i_p - i_n$ ), and flows from the terminal z into an impedance  $Z_z$ . The voltage drop at the terminal z is transferred to a current at the terminal x ( $i_x$ ) by a  $g_m$ -parameter, which is electronically controllable by an external bias current.

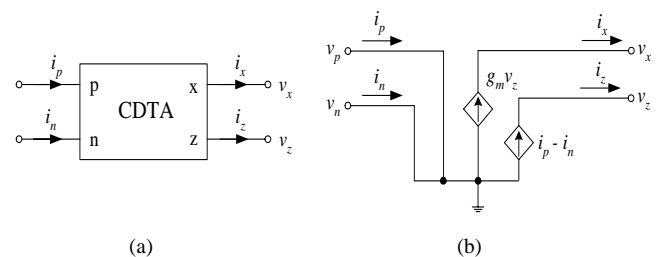

Fig. 1 : CDTA  
(a) circuit symbol (b) equivalent circuit

The possible bipolar realization of the CDTA used in this work is shown in Fig.2. The circuit consists of a current differencing circuit  $Q_1$ - $Q_{11}$  and a transconductance amplifier  $Q_{12}$ - $Q_{24}$ . Therefore, in this case, the transconductance gain  $g_m$  is directly proportional to the external bias current  $I_B$ , which can be written by :

$$g_m = \frac{I_B}{2V_T} \quad (2)$$

where  $V_T \cong 26$  mV at  $27^\circ\text{C}$  is the thermal voltage.

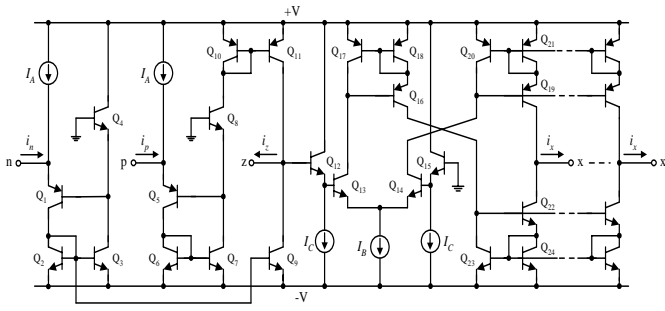

Fig.2 Possible bipolar realization of the CDTA.

### III. PROPOSED CDTA-BASED FILTER REALIZATIONS

#### A. Proposed Topology 1

Fig.3 shows the proposed topology 1 of current-mode CDTA-based filters. In this configuration, the filters comprise of a feed-forward path consisting of CDTAs connected in cascade and one feedback path for Fig.3(a), and two feedback paths for Fig.3(b). Note that all the implementations with low-input and high-output impedances require only two CDTAs and two grounded passive elements, which is beneficial from the point of view of integrated circuit (IC) fabrications [6]-[7], and permit easy cascading in current-mode operation. According to the proposed topology 1 shown in Fig.3, the realizations of general current transfer functions can be divided into two cases by the following descriptions.

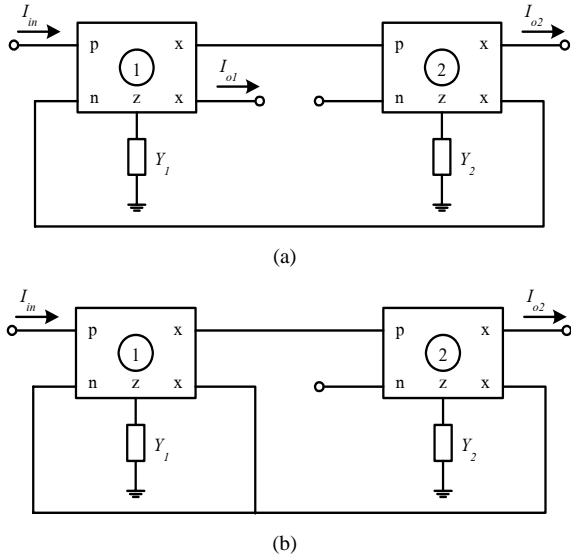

Fig. 3 : Proposed topology 1  
(a) Case 1 (b) Case 2

**Case 1 :** From Fig.3(a) ;

$$\frac{I_{o1}}{I_{in}} = \frac{g_{m1}Y_2}{Y_1Y_2 + g_{m1}g_{m2}} \quad (3)$$

and 
$$\frac{I_{o2}}{I_{in}} = \frac{g_{m1}g_{m2}}{Y_1Y_2 + g_{m1}g_{m2}} \quad (4)$$

**Case 2 :** From Fig.3(b) ;

$$\frac{I_{o2}}{I_{in}} = \frac{g_{m1}g_{m2}}{Y_1Y_2 + g_{m1}Y_2 + g_{m1}g_{m2}} \quad (5)$$

where the parameters  $g_{mi}$  and  $Y_i$  are the transconductance gain and the grounded admittance of the  $i$ -th CDTA, respectively. Owing to the parameter  $g_{mi}$  is linearly tunable with the bias current of the CDTA, it therefore lends electronic tunability to filter parameters. It should be noted that electronic tunability becomes very important when the filter is in a variety of design specifications and in the integrated form. From equations (3)-(5), the proposed filter topology 1 can realize different current-mode filtering functions by appropriately choosing the admittances  $Y_1$  and  $Y_2$ . For example, in equation (3), if  $Y_1 = g_1 + sC_1$ ,  $Y_2 = u8u = sC_2$ , then the BP filter with unity passband gain ( $H_0 = 1$ ) can be realized. Table 1 summaries all the possible current transfer functions obtained from the proposed topology 1.

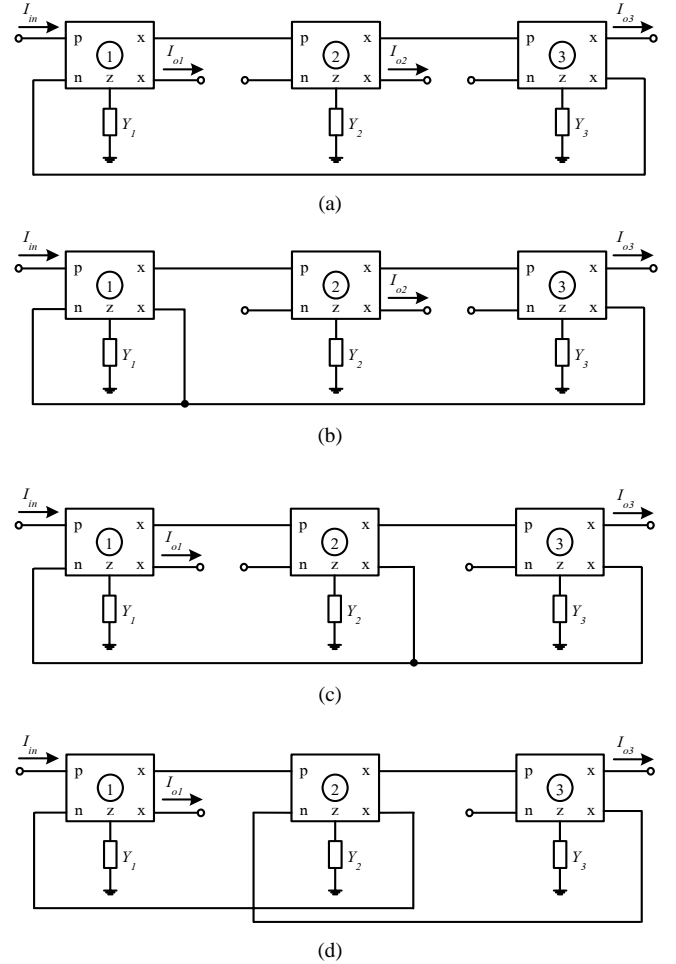

Fig. 4 : Proposed topology 2  
(a) Case 1 (b) Case 2 (c) Case 3 (d) Case 4

TABLE 1  
All the possible filter realizations of the proposed topology 1.

Case	Component condition	Function	$\omega_o$	$Q$ -factor	$H_0$	
1 Fig.3(a)	$Y_1 = g_1 + sC_1$	$g_{m1} = g_1$	Eq.(3), BP = $I_{o1}/I_{in}$	$(g_{m1}g_{m2}/C_1C_2)^{1/2}$	$(g_{m2}C_1/g_{m1}C_2)^{1/2}$	1
	$Y_2 = sC_2$	---	Eq.(4), LP = $I_{o2}/I_{in}$	$(g_{m1}g_{m2}/C_1C_2)^{1/2}$	$(1/g_1)(g_{m2}C_1/g_{m1}C_2)^{1/2}$	1
2 Fig.3(b)	$Y_1 = sC_1$ $Y_2 = sC_2$	---	Eq.(5), LP = $I_{o2}/I_{in}$	$(g_{m1}g_{m2}/C_1C_2)^{1/2}$	$(g_{m1}C_1/g_{m2}C_2)^{1/2}$	1

TABLE 2  
All the possible filter realizations of the proposed topology 2.

Case	Component condition	Function	$\omega_o$	$Q$ -factor	$H_0$	
1 Fig.4(a)	$Y_1 = g_1 + sC_1$	$g_{m1} = g_1$	Eq.(6), BP = $I_{o1}/I_{in}$	$(g_{m1}g_{m2}g_{m3}/g_3C_1C_2)^{1/2}$	$(g_{m2}g_{m3}C_1/g_{m1}g_3C_2)^{1/2}$	1
	$Y_2 = sC_2$	$g_{m3} = g_3$	Eq.(7), LP = $I_{o2}/I_{in}$	$(g_{m1}g_{m2}/C_1C_2)^{1/2}$	$(g_{m2}C_1/g_{m1}C_2)^{1/2}$	1
	$Y_3 = g_3$	---	Eq.(8), LP = $I_{o3}/I_{in}$	$(g_{m1}g_{m2}g_{m3}/g_3C_1C_2)^{1/2}$	$(g_{m2}g_{m3}C_1/g_{m1}g_3C_2)^{1/2}$	1
2 Fig.4(b)	$Y_1 = sC_1$ $Y_2 = g_2$ $Y_3 = sC_3$	$g_{m2} = g_2$	Eq.(9), BP = $I_{o2}/I_{in}$	$(g_{m1}g_{m3}/C_1C_3)^{1/2}$	$(g_{m3}C_1/g_{m1}C_3)^{1/2}$	1
		---	Eq.(10),LP = $I_{o3}/I_{in}$	$(g_{m1}g_{m2}g_{m3}/g_2C_1C_3)^{1/2}$	$(g_{m2}g_{m3}C_1/g_{m1}g_2C_3)^{1/2}$	1
3 Fig.4(c)	$Y_1 = g_1$ $Y_2 = sC_2$ $Y_3 = sC_3$	---	Eq.(11), HP = $I_{o1}/I_{in}$	$(g_{m1}g_{m2}g_{m3}/g_1C_2C_3)^{1/2}$	$(g_1g_{m3}C_3/g_{m1}g_2C_2)^{1/2}$	$(g_{m1}/g_1)$
		---	Eq.(12), LP = $I_{o3}/I_{in}$	$(g_{m1}g_{m2}g_{m3}/g_1C_2C_3)^{1/2}$	$(g_1g_{m3}C_3/g_{m1}g_2C_2)^{1/2}$	1
4 Fig.4(d)	$Y_1 = g_1$ $Y_2 = sC_2$ $Y_3 = sC_3$	---	Eq.(13), BS = $I_{o1}/I_{in}$	$(g_{m2}g_{m3}/C_2C_3)^{1/2}$	$(g_1/g_{m1})(g_{m3}C_2/g_{m2}C_3)^{1/2}$	$(g_{m1}/g_1)$
		$g_{m1} = g_1$	Eq.(14), LP = $I_{o3}/I_{in}$	$(g_{m2}g_{m3}/C_2C_3)^{1/2}$	$(g_{m3}C_2/g_{m2}C_3)^{1/2}$	1

### B. Proposed Topology 2

Based on the same configuration shown in Fig.3, if an additional CDTA3 and the admittance  $Y_3$  are connected as shown in Fig.4, then the proposed topology 2 will be obtained. The resulting configuration possibly corresponds to four cases as follows.

**Case 1 :** Form Fig.4(a), there is only one feedback path and three output currents available. Routine calculations yield the various current transfer functions as follows.

$$\frac{I_{o1}}{I_{in}} = \frac{g_{m1}Y_2Y_3}{Y_1Y_2Y_3 + g_{m1}g_{m2}g_{m3}} \quad (6)$$

$$\frac{I_{o2}}{I_{in}} = \frac{g_{m1}g_{m2}Y_3}{Y_1Y_2Y_3 + g_{m1}g_{m2}g_{m3}} \quad (7)$$

and 
$$\frac{I_{o3}}{I_{in}} = \frac{g_{m1}g_{m2}g_{m3}}{Y_1Y_2Y_3 + g_{m1}g_{m2}g_{m3}} \quad (8)$$

**Case 2 :** From Fig.4(b), in this case, there are two feedback paths and therefore two output currents available. The current transfer functions are

$$\frac{I_{o2}}{I_{in}} = \frac{g_{m1}g_{m2}Y_3}{Y_1Y_2Y_3 + g_{m1}Y_2Y_3 + g_{m1}g_{m2}g_{m3}} \quad (9)$$

and 
$$\frac{I_{o3}}{I_{in}} = \frac{g_{m1}g_{m2}g_{m3}}{Y_1Y_2Y_3 + g_{m1}Y_2Y_3 + g_{m1}g_{m2}g_{m3}} \quad (10)$$

**Case 3 :** From Fig.4(c), there are two feedback paths and two output currents available from the third possible

connection, where the corresponding current transfer functions are derived as :

$$\frac{I_{o1}}{I_{in}} = \frac{g_{m1}Y_2Y_3}{Y_1Y_2Y_3 + g_{m1}g_{m2}Y_3 + g_{m1}g_{m2}g_{m3}} \quad (11)$$

and 
$$\frac{I_{o3}}{I_{in}} = \frac{g_{m1}g_{m2}g_{m3}}{Y_1Y_2Y_3 + g_{m1}g_{m2}Y_3 + g_{m1}g_{m2}g_{m3}} \quad (12)$$

**Case 4 :** From Fig.4(d), three feedback paths are connected in this realization, where the current transfer functions are

$$\frac{I_{o1}}{I_{in}} = \frac{g_{m1}(Y_2Y_3 + g_{m2}g_{m3})}{Y_1Y_2Y_3 + g_{m1}g_{m2}Y_3 + g_{m2}g_{m3}Y_1} \quad (13)$$

and 
$$\frac{I_{o3}}{I_{in}} = \frac{g_{m1}g_{m2}g_{m3}}{Y_1Y_2Y_3 + g_{m1}g_{m2}Y_3 + g_{m2}g_{m3}Y_1} \quad (14)$$

Clearly, depending on the choice of component conditions of  $Y_1$ ,  $Y_2$ , and  $Y_3$ , equations (6)-(14) also provide different current transfer functions. As an example, if we select  $Y_1 = g_1$ ,  $Y_2 = sC_1$ , and  $Y_3 = sC_3$ , then equation (13) can be realized the BS filter function. All the possible filter functions available from the proposed topology 2 are summarized in Table 2.

From the expressions in Tables 1 and 2, we can see that all the filter characteristics provide electronic tunability. The filter parameters  $\omega_o$  and  $Q$ -factor can be tuned by controlling the associated transconductance  $g_{mi}$  through an adjustment of the bias currents of the CDTAs. For both topologies, the sensitivities

$$\left[ S_x^G = \left( \frac{x}{G} \right) \left( \frac{\partial G}{\partial x} \right) \right] \text{ of } G = \omega_o, Q \text{ with respect}$$

to active and passive components  $x = g_i, g_{mi}, C_i$  are evaluated as either 0, or  $\pm 0.5$ , or  $\pm 1$ , all of which are small. Therefore, the proposed filter topologies 1 and 2 also display low sensitivities.

#### IV. DESIGN EXAMPLES AND SIMULATION RESULTS

PSpICE simulations have been used to verify the characteristics of the proposed filter topologies. The CDTA were performed by the schematic bipolar implementation given in Fig.2 with the transistor model parameters of PR100N (PNP) and NP100N (NPN) of the bipolar arrays ALA400 from AT&T [8]. The supply voltage are  $\pm V = \pm 3V$ , and the bias currents are  $I_A = I_C = 100 \mu A$ . Here, two design examples are given.

As the first example, consider the realization of the BP and LP responses based on the proposed topology 1 of Fig.3(a) with the natural frequency  $f_o = \omega_o/2\pi \cong 159 \text{ kHz}$ ,  $Q$ -factor = 1, and  $H_0 = 1$ . According to the component condition of case 1 given in Table 1, the component values of the filter in this example are determined as :  $g_1 = 1 \text{ mA/V}$ ,  $g_{m1} = g_{m2} = 1 \text{ mA/V}$  (i.e.  $I_{B1} = I_{B2} \cong 52 \mu A$ ) and  $C_1 = C_2 = 1 \text{ nF}$ . The simulated filter characteristics are shown in Fig.5. It is confirmed that the proposed topology 1 of Fig.3(a) can certainly realize two types of the biquadratic function, and that the simulated values almost agrees with the theoretical one in frequency band up to 10 MHz.

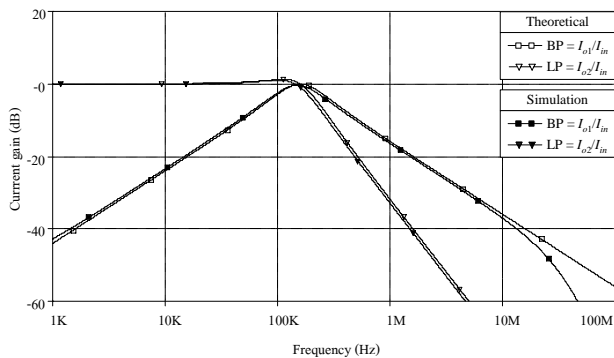

Fig. 5 : Simulated current responses of the proposed topology 1 of Fig.3(a).

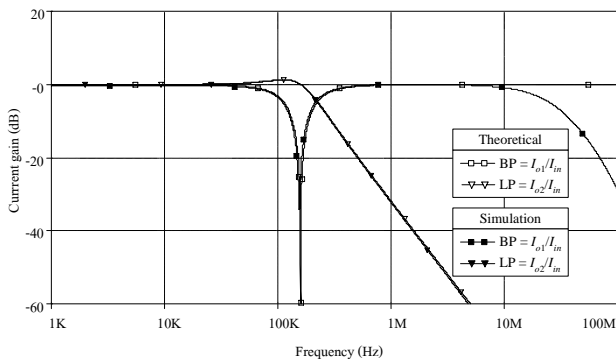

Fig. 6 : Simulated current responses of the proposed topology 2 of Fig.4(d).

In the second example, the proposed filter topology 2 of Fig.4(d) was designed to obtain  $f_o \cong 159 \text{ kHz}$ ,  $Q$ -factor = 1,

and  $H_0 = 1$ . Using the design equations of case 4 in Table 2, the filter component values are :  $g_1 = 1 \text{ mA/V}$ ,  $g_{m1} = g_{m2} = g_{m3} = 1 \text{ mA/V}$  and  $C_1 = C_2 = 1 \text{ nF}$ . Fig.6 shows the filter's simulated frequency characteristics, which are exactly as expected.

#### V. CONCLUSIONS

This paper has proposed an approach to provide the systematic and structural method for generating cascadable current-mode filters employing CDTAs. The proposed filter topologies are composed of only CDTAs and grounded elements, which is beneficial in IC implementation. The filters can generate the general current transfer functions, i.e., LP, BP, HP, BS. The resulting filter characteristics can be electronically tuned by controlling the  $g_m$ -value of the CDTA, and all the active and passive sensitivities are low. With low-input and high-output impedances, the proposed filters are very suitable for cascading in current-mode operation.

#### ACKNOWLEDGMENT

This work was supported by the Commission on Higher Education, Ministry of Education, Thailand, through the Research Group Development Programme (CHE-RG-01A), Research Group in Microelectronics for Communications.

#### REFERENCES

- [1] D. Biolk, "CDTA-Building block for current-mode analog signal processing", *Proceedings of the ECCTD'03*, vol.3, Krakow, Poland, pp.397-400, 2003.
- [2] D. Biolk, and V. Biolkova, "Universal biquads using CDTA elements for cascade filter design", *Proceedings of the CSCC 2003*, Corfu, Greece, 2003.
- [3] A. T. Bekri, and F. Anday, "Nth-order low-pass filter employing current differencing transconductance amplifiers", *Proceedings of the 2005 European Conference on Circuit Theory and Design*, vol.2, pp.193-196, 2005.
- [4] D. Biolk, and V. Biolkova, "CDTA-C current-mode universal 2<sup>nd</sup>-order filter", *Proceedings of the 5<sup>th</sup> WSEAS International Conference on Applied Informatics and Communication*, Malta, pp.411-414, 2005.
- [5] A. U. Keskin, D. Biolk, E. Hancioglu, and V. Biolkova, "Current-mode KHN filter employing current differencing transconductance amplifiers", *International Journal of Electronics and Communications (AEU)*, vol.60, pp.443-446, 2006.
- [6] M. Bhusan, and R.W. Newcomb, "Grounding of capacitors in integrated circuit", *Electronics Letters*, vol.3, pp.148-149, 1967.
- [7] K. Pal, and R. Singh, "Inductorless current conveyor allpass filter using grounded capacitors", *Electronics Letters*, vol.18, pp.47, 1982.
- [8] D.R. Frey, "Log-domain filtering: an approach to current-mode filtering", *IEE Proc. G, Circuits, Devices and Systems*, vol.140, pp 406-416, 1993.