



Title	Inbreeding depression by recessive deleterious genes affecting female fecundity of a haplo-diploid mite
Author(s)	Saito, Y.; Sahara, K.; Mori, K.
Citation	Journal of Evolutionary Biology, 13(4), 668-678 https://doi.org/10.1046/j.1420-9101.2000.00198.x
Issue Date	2000
Doc URL	http://hdl.handle.net/2115/926
Rights	Copyright © 2000, Blackwell Publishing
Type	article (author version)
File Information	JEB13-4.pdf



[Instructions for use](#)

Inbreeding depression by recessive deleterious genes affecting female fecundity of a haplo-diploid mite

Y. Saito¹, K. Sahara² and K. Mori¹

¹ Laboratory of Animal Ecology, Graduate School of Agriculture, Hokkaido University, Kita-ku, Sapporo, 060-8589, Japan, e-mail: yutsat@res.agr.hokudai.ac.jp

² Laboratory of Applied Molecular Entomology, Graduate School of Agriculture, Hokkaido University, Kita-ku, Sapporo, 060-8589, Japan

Key words: genetics, heterosis, deleterious recessive, Tetranychidae, subsociality, backcross, female-limited genes

Running head: Inbreeding depression in haplo-diploidy

¹ Tel: +81-11-706-3893, Fax: +81-11-757-5595

Abstract

The effect of inbreeding on haplo-diploid organisms has been regarded as very low, because deleterious recessive genes on hemizygous (haploid) males were immediately purged generation by generation. However, we determined such recessive genes to decrease female fecundity in a population of *Schizotetranychus miscanthi* Saito which is known in the Acari as a subsocial species with haplo-diploidy. In mother-son inbreeding experiments, there was no depression in egg hatchability nor in the larval survival of progeny over 4 generations. There was, on the other hand, significant inbreeding depression in the fecundity with increasing f -value. Crosses between two lineages, one having deleterious effects on the fecundity and the other having no such effects, established during the inbreeding, revealed heterosis, and backcrosses showed that the depression was caused by deleterious recessive(s). These results strongly suggest the existence of some deleterious genes governing only the traits of adult females in wild populations of haplo-diploid organisms.

Introduction

In haplo-diploid organisms, deleterious mutations are immediately selected out through hemizygous males in accordance with the mutation-selection balancing theory of deleterious recessives (Smith and Shaw, 1980; Matsuda, 1987; Atmer, 1991). Therefore, the equilibrium frequency of a deleterious recessive gene in haplo-diploidy (male-haploidy) is lower than that in diplo-diploidy (Atmer, 1991). However the hypothesis on equilibrium frequency of deleterious recessives in haplo-diploidy is uncertain. If there are genes which govern only the traits of diploids, i.e. "female-limited genes", the equilibrium frequency of such recessive genes may not be so different between haplo-diploid and diplo-diploid organisms (Crozier, 1985; Saito, 1994).

Saito(1994, 1995a) thus presented an idea about a proximate factor of the evolution of eusociality, especially sterile castes, in relation to the inequality of fecundity due to deleterious recessives: The haplo-diploid genetic system *a priori* provided high tolerance for the shift from out-breeding to inbreeding (because of the low frequency of deleterious genes), and deleterious

recessives limited to the female sex have often made homozygous females sterile in this system under some inbreeding conditions. Such deleterious recessives might become sources of sterile-female castes in male-haploid organisms, if they linked with genes governing care-taking of relatives. Therefore Saito (1995b) stressed the importance of genetic studies through inbreeding experiments on the retained pattern of mildly deleterious recessives in haplo-diploid organisms.

Mites are small organisms of low mobility, such that they are expected to be more or less under inbreeding conditions (Mitchell, 1973; Saito, 1995b). Helle (1965) demonstrated inbreeding effects on the egg hatchability of the two-spotted spider mite, *Tetranychus urticae* Koch. From the above report, Helle and Overmeer (1975) concluded that inbreeding in spider mites generally does not lead to severe deterioration of general viability, and is restricted to factors affecting reproduction which might be sex (female)-limited. Their studies however, were not always sufficient because they did not observe the process of the occurrence of depression with the intensity of inbreeding (i.e. increase of f -value of Wright, 1922).

Spider mites are phytophagous, so that the manipulation of food conditions which may greatly affect mite life history and morphology is generally difficult (Saito, 1990). Although environmental variances in such factors are inevitable during long-term genetic studies, good manipulation of experiments and some statistical methods developed recently to eliminate such factors by outbreeding controls may reduce these difficulties (Pray and Goodnight, 1995). This, together with their short life cycles and small body sizes, has led to spider mites becoming very useful model materials for genetic studies of haplo-diploid organisms. For these reasons, we tried to evaluate the nature of inbreeding depression in a haplo-diploid spider mite species.

Materials and Methods

The mite species used was *Schizotetranychus miscanthi* Saito collected from a perennial grass, *Miscanthus sinensis* Andress. (Gramineae) in Hinomisaki in Shimane Prefecture, Japan on Oct. 2, 1995. This species is known as a nest-building subsocial species and shows variation in male aggressiveness (Saito, 1995b, 1997, Saito and Sahara, 1999). We selected two subpopulations, which were about 300m distant from each other and isolated by roads, in order to obtain sufficient genetic variation. From each subpopulation, at least 300 individuals (mainly adults) were randomly collected and brought to our laboratory (Lab. Animal Ecology, Hokkaido University, Sapporo) for rearing. We called these two subpopulations B1 and B2 strains hereafter. In addition, a strain called Mc (Mixed culture) was established by mixing the two subpopulations and maintained by mass culture (consisting of at least 500 individuals) for use as a source of males for random mating (we regarded this as a kind of outbreeding, see below).

Establishment of inbreeding lineages and outbreeding controls

Four virgin females from the strain of B1 and 2 from B2 were randomly picked up and reared individually on detached leaves (1 × 2 cm leaves were randomly picked from *M. sinensis* cultivated in a greenhouse) spread on water-soaked cotton in a petri dish under 24 ± 1°C, 15L-9D and 50-80%RH conditions. About 13 days after unfertilized oviposition (unmated females produce haploid eggs), these females were mated with males of a different strain (this procedure was used to give consistency to all experiments-see below). Then 4 lineages (L1, L2, L3 and L6) from the mating of B1 females and B2 males, and 2 lineages (L4 and L5) from that of B2 females and B1 males were obtained. They were used as grandparents (hereafter called GP) for the following inbreeding lineages and outbreeding controls. Because their genetic constitution was sufficiently mixed by crossing between subpopulations at the GP generation, the Wright's (1922) inbreeding coefficient f at P generation was assumed to be 0.

<Figs.1 & 2

In order to establish inbred lineages, virgin females which developed from early eggs of each GP, were individually placed on detached leaves and allowed to deposit unfertilized eggs for approximately 13 days (this period is necessary for sons' maturation) after maturity. Then, they were mated with their own sons; they performed mother-son inbreeding (Fig. 1). One of the inbred females was used as the mother (P) of each lineage for the next generation (F₁). This procedure was repeated for 6 generations (until F₆).

For establishing outbreeding controls, the same procedures were followed except for mother-son mating: After about 13 days of unfertilized oviposition each female was mated with males of Mc strain; they were assumed to perform outbreeding. One of the outbred females of each lineage was then used as the mother of each lineage for the next generation. This procedure was repeated for 6 generations.

Fitness evaluation

Inbreeding effects were observed for the following 4 life-history traits: Experiment I

The immediate effect of mother-son inbreeding on the early survival of their progeny (Fig.1). The offspring from mother-son mating (2 fertilized females per lineage) of each lineage/generation were observed for their hatchability and larval survival (until the molt of protonymph). No differences between lineages were observed, because of insufficient sample sizes. Number of replicates (number of mothers) in this experiment was limited to 12 (sometimes less than 12 because of accidents). This experiment was conducted from P to F₄ generation.

Experiment II

The effect on the fertilized oviposition of inbred lineages when mated with Mc males (Fig.2). Virgin (quiescent deutonymph) females which developed from eggs of inbred mothers of each lineage were picked up and reared individually. They were mated just after molting with males of the Mc strain (mixed strain of B1 and B2 sub-populations), then the number of eggs (including both female and male offspring) laid for 10 days was observed. This experiment was conducted from P to F₆ generation. No. of replicates of each lineage (per generation) varied from 5 to 10 because of inconsistent numbers of available females.

Experiment III

The effect on the unfertilized oviposition of inbred lineages (Fig. 2). Virgin females which developed from eggs of inbred mothers of each lineage were picked up and reared individually without males. They were kept unmated and the number of eggs (only haploid eggs) laid for 10 days was observed. The number of replicates for each lineage (per generation) varied from 5 to 10 because of inconsistent number of available females.

Experiment IV

The early survival rates (from egg to the molt of protonymph) of the offspring of Experiment II were observed to determine the indirect (maternal) effect of inbreeding (in Fig.2). It should be noted that F₁ generation in this experiment corresponds to P generation in the other experiments, i.e. $f=0$ at F₁ and $f=0.938$ at F₅. Number of eggs observed per female varied from 3 to 15 because of inconsistent oviposition.

All the experiments were accompanied by the control experiments for the outbreeding lineage. They were started in Dec. 1995 (GP) and completed in Sep. 1996 (6th generation).

Out-breeding depression

There was a possibility that females produced by successive inbreeding may develop a type of incompatibility to outbreeding (such as hybrid dysgenesis in Kidwell, 1985 and outbreeding depression in Meester, 1993). Experiment V was thus conducted to determine this possibility: Additionally, 6 females were taken and mated with their brothers at the start of experiment II of

the F₆ generation. The oviposition of these fertilized females was then compared with that of the females of experiment II (the latter outbred with Mc strain males as in Fig. 2).

Genetic study

Inter-lineage cross and backcross experiments (experiment VI) were conducted between two lineages (L2 and L5) showing a different response to inbreeding to determine their genetic bases 6 months after the inbreeding experiment had been completed. In order to obtain a sufficient number of individuals for crossing, these two lineages were increased by within-lineage mating (mostly by sib-mating) for approximately 4 generations after having been maintained until the 10th generation by mother-son mating.

Twelve virgin females were randomly picked up from each lineage culture. Half (6) were crossed with males of the same lineage and the other half (6) were crossed with males of the other lineage. Each pair was kept individually on a leaf disc for oviposition. Then 4 to 7 females developed from the eggs laid by each parent female were used for the 10-day oviposition experiment. The number of replicates per cross type are shown in Figs 6 & 7.

Since the results of the outbreeding control of experiments II and III strongly suggested that host plant conditions vary greatly and affect female oviposition, we tried to eliminate such environmental variance from these genetic experiments in order to get more precise data. We made an effort to give uniformity to the detached host leaves used in all cross experiments: A leaf of *M. sinensis* was divided into 4 (for 4 cross types in the inter-lineage cross) or 6 (for 6 cross types in the backcross) pieces, which were then randomly provided as sets for the experiment. All host leaves used in all cross types were thus regarded as having the same quality. This procedure as well as the synchronization of all experiments might serve to minimize the variation in nutritional conditions of the host plant.

Statistics

Inevitable environmental variance caused by host plant conditions in experiments I, II, III and IV was eliminated by using the magnitude of the variances of outbreeding controls in accordance with Pray and Goodnight (1995). The data were analyzed by one-way Anova, two-way Anova, Ancova and Scheffe's *post hoc* test for multiple comparisons using the statistical software StatView ver.5.0 for Macintosh computers. In addition, the sample sizes for the early survival rates (experiments I and IV) were unavoidably small due to mites' low fecundity (5 to 20 eggs per female) such that the percent survival data was arcsin-transformed according to Mosteller and Youtz (1961) (Freeman-Turkey transformations for small n). Further details are described in the results.

<Figs.3 & 4, Table 1&2

Results

Experiment I

After the percent survival data were arcsin-transformed, we performed a linear regression of the outbreeding-control means on the Wright's f -value. The residuals from the regression were then regarded as to be environmental variances. Another regression analysis of experimental values on the residuals obtained above was performed and the residuals of the second regression were then regarded as providing data corrected for environmental effects (Pray and Goodnight, 1995).

By the regression analysis of the corrected values of early survival rates on f -value, both regression coefficients were not significant (Table 1). Namely the early survival rate indicated no linear trend with the increase of f -value, showing no immediate effect of the mother-son inbreeding on the early survival of their progeny.

All basic statistics of the experiments I to V are tabulated in the appendices.

< Table 3&4

Experiment II

After correcting the data through the variance of the outbreeding controls (as mentioned above), we performed Ancova analysis with f -value as a covariate for all lineages. There were no significant differences between the slopes of regression lines of lineages (Fig. 3), showing no interaction between f -value and lineage difference (Table 2). We found significant differences both in f -values and lineages as shown in Table 2.

The regression analysis for the number of eggs laid by the females of each lineage on f -value showed that there were significant lines (having negative slopes) for the 3 lineages (Fig. 3 and Table 3) even by the use of the sequential Bonferroni's test.

Experiment III

Whether or not inbreeding in a parental generation affects the unfertilized oviposition of progeny females was tested. We corrected the data of experiment III in the same way as in experiments I and II.

There were no significant differences between lineages, nor in f -value, whereas there was a significant interaction between f -value and lineage by Ancova ($P < 0.018$ in Table 4). Such a significant difference among slopes of the regression lines forced us to analyze the lineage data separately.

The regression analysis performed for each lineage showed that the number of eggs of lineage L2 significantly decreased with increase of f -value ($P < 0.05$ by the sequential Bonferroni's test in Table 5). Although we could not say that there was an effect of inbreeding on the unfertilized oviposition in this population because of the significant interaction between lineage and generation in Ancova, it should be noted that one lineage (L2) apparently suffered an inbreeding effect on its uninseminated oviposition (Fig 4) .

It was important to note that the L2 lineage was also had a reduction in the fertilized oviposition in experiment II, and that the decrease in the number of eggs/10-day was not a result of the early death of ovipositing females in both experiments II and III.

<Table 5

Experiment IV

After correcting the arcsin-transformed data through the variance of the outbreeding control (mentioned above), we performed Ancova with f -value as a covariate for whole regression lines in Fig. 5. There was no significant difference among slopes, showing no interaction between f -value and lineage difference. Even after eliminating the interaction effect from the analysis, we did not find any significant differences in f -values nor in lineages (Table 6). The regression analysis of the early survival rates of the progeny on f -value also did not show any significant regression lines (by the sequential Bonferroni's test) in this experiment (Fig. 5 and Table 7).

<Fig.5, Table s 6 & 7

Experiment V

In experiment II as mentioned before, females produced from inbred parents were mated with the Mc strain males. Therefore, we should consider the possibility that outbreeding after continuous inbreeding directly affected the oviposition of females, especially in later generations. Anova testing (error $df=105$) revealed that the interaction of lineage x breeding-type was not significant ($df=5$, $F=0.95$, $P>0.45$). There was no difference between breeding types (after eliminating interaction, sib-mating vs. outbreeding: $df=1$, $F=3.08$, $P>0.08$), whereas there was a significant difference between lineages ($df=5$, $F=6.32$, $P<0.0001$). These showed that outbreeding had no significant effect on the oviposition rate of females from inbred lineages, while there was a big difference in oviposition rate between lineages(at the F_6 generation).

Scheffe's *post hoc* test between lineages revealed that the oviposition rate of L2 was significantly different from the other 5 lineages at $P < 0.03$.

Experiment VI

Lastly, we observed the genetic characteristics of the inbreeding depression observed in experiments II and III. The lineage L2 decreased in fecundity in experiments II and III with successive inbreeding, while no such decrease was found in L5 (Figs 3, 4, Tables 3 and 5). Thus, cross experiments between these two lineages were performed at about the 14th generation after establishment of the inbreeding lineages.

Nineteen to twenty-nine female offspring produced by 6 parental females of each cross type were lumped and their oviposition observed for 10 days. In both the fertilized (mated with Mc males) and unfertilized females (Fig. 6), there were significant differences in the 10-day oviposition rate between the cross types of parents by Anova (the former: error $df=98$, $df=3$, $F=8.24$, $P < 0.001$, and the latter: error $df=101$, $df=3$, $F=13.421$, $P < 0.0001$). The differences were apparently due to the lower oviposition rate in L2C2 (for L2C2 vs. L5C5, L2C2 vs. L2C5 and L2C2 vs. L5C2, $P < 0.01$, < 0.0002 and < 0.0008 in fertilized oviposition, and for all combinations, $P < 0.0001$ in unfertilized oviposition by Scheffe's *post hoc* test for multiple comparisons, respectively), showing that heterosis concurred in L2C5 and L5C2. This suggested that the L2 lineage carried some genetically deleterious factors.

In order to further confirm the genetic characteristics, backcross experiments (for the combination of the crosses, see Fig 7) were carried out in the same manner as those of the inter-lineage cross. In this experiment, only the unfertilized oviposition of progeny females was observed. There was a significant difference in the 10-day oviposition rate between the cross types of parents by Anova (error $df=202$, $df=5$, $F=16.93$, $P < 0.0001$). As seen in Fig. 7, L2C5B2 and L5C2B2 females produced by the backcross of L2 males laid a medium number of eggs between those laid by L2C2C2 (depressed control) and L5C5C5 (normal control), while L2C5B5 and L5C2B5 laid similar numbers of eggs to the normal controls. The number of eggs laid by the L2C5B2 was significantly different from those laid by L2C5B5, L5C2B5, L2C2C2 and L5C5C5 ($P < 0.017$, $P < 0.026$, $P < 0.023$ and $P < 0.013$ by Scheffe's *post hoc* test, respectively). Furthermore, the number of eggs laid by the L5C2B2 was significantly different from that of L2C2C2 ($P < 0.0007$). However, the numbers of eggs laid by L2C5B5 and L5C2B5 females did not differ from that of L5C5C5 (both at $P > 0.90$), but differed significantly from that of L2C2C2 (both at $P < 0.0001$).

These results showed that the recessive genes supposed in the L2 lineage had been heterozygous in the F₁ progeny of L2C5 and L5C2 parents and were segregated in L2C5B2 and L5C2B2 females by the backcrosses.

L1, L3, L5 and L6 strains used in this study are still being maintained in our laboratory mainly by sib-mating, though L2 is now due to sterility.

<Figs. 6&7

Discussion

Several authors have theoretically demonstrated that a lower equilibrium frequency of deleterious recessive genes can be expected from haplo-diploidy than from diplo-diploidy under random mating conditions (Crozier, 1985; Matsuda, 1987; Atmer, 1991). Therefore, some evolutionary theories concerning the sex-ratio and mating structure of haplo-diploidy have *a priori* involved the lower effect of inbreeding (Matsuda, 1987; Wensch, 1993). However, there are only a few empirical studies on inbreeding depression of haplo-diploidy (Cale and Gowen, 1956; Bruckner, 1978; Sorati et al., 1996), and its nature is not well known. The difficulty in

rearing species having this genetic system under controlled conditions, and scarce knowledge about the structure of the mating systems make it difficult to evaluate the importance of inbreeding depression on the evolution of sociality in haplo-diploid organisms (Saito, 1995a).

As expected from the theories mentioned above, the inbreeding effects on the early survival of *S. miscanthi* immatures were undetectable for 4 generations in the progeny of inbred parents (both in experiments I and IV). This suggests a lower frequency of deleterious recessive genes which govern the immatures' early survival.

On the other hand, we could demonstrate that there is inbreeding depression working on reproductive ability in the progeny of females. Crozier (1985) and Saito (1994) argued that if there are genes which govern only the traits of diploid females, i.e. sex-limited, the equilibrium frequency of such recessive genes may not be so different between haplo-diploid and diplo-diploid organisms { $SQR(2u/s)$ in the former and $SQR(3u/2s)$ in the latter, where u =mutation rate, s =selection coefficient}. The present finding apparently supports their hypothesis. Although there is no way to evaluate whether the degree of depression in *S. miscanthi* is at a similar level to diplo-diploid species having the same ecology, the important point is that there are mildly deleterious genes which cause inbreeding depression in adult females of haplo-diploid organisms. Furthermore, we could show from the cross and backcross experiments that the depression was primarily caused by recessive alleles.

Another important question is how many loci and alleles are responsible for the depression in fecundity. We could not determine this because of the difficulty in maintaining constant rearing conditions, especially host plant conditions, for 2 generations (F_1 and F_2), which is a prerequisite for the estimation of an effective number of additive and dominant loci (Lande, 1981; Olivier and Janss, 1993).

Because the grandparents used in this study originated from two distant subpopulations, we could not determine whether the inbreeding depression detected in this study was the effect of the deleterious genes being retained in a single subpopulation or if it was concerned with the breakdown of a heterosis caused by the cross between subpopulations at the GP generation. If it is the latter case, we observed that crossing with unrelated individuals in normally inbreeding subpopulations resulted in a significant fitness gain by heterosis as expected by Charlesworth and Charlesworth (1987).

Whether inbreeding depression will occur or not in a species already inbred under natural conditions is the other important question under discussion (Shield, 1982). This question may involve the mechanisms by which deleterious genes or genetic variation are maintained within a small population. Spider mites have low mobility, so that they are more or less living under inbreeding conditions (Mitchell, 1973, Osakabe and Komazaki 1999). The *Schizotetranychus celarius* species complex including *S. miscanthi* make woven nests and live gregariously within the nests. Overlapping more than two generations in a nest, which observed in *S. miscanthi* suggests that they usually inbreed between sibs. On the other hand, there is clinal variation in male antagonism and the cline may be closely related to the difference in relatedness between interactors (Saito, 1995b; Saito and Sahara, 1999). Because the males of the *S. miscanthi* population used in the present study showed high aggressiveness (Saito and Sahara, 1999), we expect the mating system of this population to be relatively outbreeding among species of the *S. celarius* species complex. Although whether the mating system (structure) of the present population is outbreeding enough to retain deleterious recessives by mutation-selection balancing theory is unknown, we believe that the mechanisms by which deleterious recessives are maintained in the population are not only "mutation-selection balance", but also some pleiotropical effects of such genes. In order to determine how genetic variation, including

deleterious recessives, is maintained in a local and small population distributing patchily, the mating system of the population has to be determined by the use of some genetic markers in the future (Saito, 1997).

Michod (1993) stated that inbreeding depression, the effect of inbreeding on genetic structure, and the effect of inbreeding on the evolution of social behavior all need to be investigated together to understand whether inbreeding has different roles to play in the origin of social behavior than it does in its maintenance. Saito (1994) proposed a theory about proximate causes of inequality (caste) among females of haplo-diploid organisms by mildly deleterious recessives retained exclusively in females. However, with no empirical data to support it, this theory faced strong criticism from Keller (1995). We believe that the present finding is one of such empirical data required to support this theory.

Acknowledgements

We thank H. Abe, S. Abe, S. Akimoto, N. Itagaki, S. Kudo, H. Matuda, H. Mori, M. Nishijima, Mh. Osakabe, T. Sakagami, K. Saito, M. Toyama, M. Umemoto, S. Urano, N. Yamamura and Y. Yasui for their valuable suggestions and help. We also appreciate the efforts of A.R. Chittenden who kindly reviewed the manuscript. Further we heartily appreciate two anonymous reviewers who kindly pointed out statistical errors and gave us the opportunity to re-analyze our raw data carefully. This work was supported by Grants-in-Aid (nos. 07454209, 09460022, 11640626) for Scientific Researches from the Ministry of Education, Science, Sports and Culture (Monbushou), Japan.

References

- Atmer, W. 1991. On the role of males. *Anim. Behav.* 41: 195-205.
- Bruckner, D. 1978. Why are there inbreeding effects in haplo-diploid systems? *Evolution* 32: 456-458.
- Cale, G.H. and J.W. Gowen. 1956. Heterosis in the honey bee (*Apis mellifera* L.). *Genetics* 41: 292-303.
- Charlesworth, D. and B. Charlesworth. 1987. Inbreeding depression and its evolutionary consequences. *Ann. Rev. Ecol. Syst.* 18: 237-268.
- Crozier, R.H. 1985. W. Helle and M.W. Sabelis (Eds.), *Spider Mites. Their Biology, Natural Enemies and Control* Vol. 1A. Elsevier, Amsterdam.
- Helle, W. 1965. Inbreeding depression in an arrhenotokous mite (*Tetranychus urticae* Koch). *Ent. Exp. Appl.* 8: 299-304.
- Helle, W. and W.P.J. Overmeer. 1973. Variability in tetranychid mites. *Ann. Rev. Entomol.* 18: 97-120.
- Keller, L. 1995. Sterility by deleterious alleles and the evolution of sociality. *J. theor. Biol.* 174: 467-469.
- Kidwell, M.G. 1995. Hybrid dysgenesis in *Drosophila melanogaster*: nature and inheritance of P element regulation. *Genetics* 111: 337-350.
- Lande, R. 1981. The minimum number of genes contributing to quantitative variation between and within populations. *Genetics* 99: 541-553.
- Matsuda, H. 1987. Conditions for the evolution of altruism, pp. 67-80. In Y. Ito, J.L. Brown and J. Kikkawa eds. *Animal Societies. Theories and Facts*. Japan Sci. Soci. Press, Tokyo.
- Meester, L.D. 1993. Inbreeding and outbreeding depression in *Daphnia*. *Oecologia* 96: 80-84.

- Michod, R.E. 1993. Inbreeding and evolution of social behavior, pp. 74-96. In N.W. Thornhill (Ed.), *The natural history of inbreeding and outbreeding*. The University of Chicago Press, Chicago and London.
- Mitchell, R. 1973. Growth and population dynamics of a spider mite (*Tetranychus urticae* K., Acarina: Tetranychidae). *Ecology* 54 : 1349-1355.
- Mosteller, F. and C. Youtz. 1961. Tables of the Freeman-Tukey transformations for the binomial and poisson distributions. *Biometrika* 48: 433-440.
- Olivier, L. and L.L.G. Janss. 1993. A note on the estimation of the effective number of additive and dominant loci contributing to quantitative variation. *Genetics* 135: 907-909.
- Osakabe, Mh. and S. Komazaki 1999. Laboratory experiments on a change in genetic structure with an increase of population density in the citrus red mite population, *Panonychus citri* (McGregor) (Acari: Tetranychidae) *Appl. Entmol. Zool.* 34: 413-420.
- Pray, L.A. and C. J. Goodnight. 1995. Genetic variation in inbreeding depression in the red flour beetle *Tribolium castaneum*. *Evolution* 49: 176-188.
- Saito, Y. 1990. Factors determining harem ownership in a sub-social spider mite (Acari, Tetranychidae). *J. Ethology* 8: 37-43.
- Saito, Y. 1994. Is sterility by deleterious recessives an origin of inequalities in the evolution of eusociality? *J. theor. Biol.* 166: 113-115.
- Saito, Y. 1995a. "Altruistic gene" a priori involves two different deleterious gene effects. A reply to Keller. *J. theor. Biol.* 174: 471-472.
- Saito, Y. 1995b. Clinal variation in male-to-male antagonism and weaponry in a subsocial mite. *Evolution* 49: 413-417.
- Saito, Y. 1997. Sociality and kin selection in Acari, pp. 443-457. In J.C. Choe and B.J. Crespi (Eds.), *The Evolution of Social Behaviour in Insects and Arachnids*. Cambridge Univ. Press, London.
- Saito, Y. and K. Sahara. 1999. Two clinal trends in male-male aggressiveness in a subsocial spider mite. *Behav. Ecol. Sociobiol.* (in press).
- Shields, W.M. 1982. *Philopatry, inbreeding, and the evolution of sex*. State University of New York Press, Albany, New York.
- Smith, R.H. and M.R. Shaw. 1980. Haplod sex ratios and the mutation rate. *Nature* 287: 728-729.
- Sorati, M., M. Newman and A.A. Hoffmann. 1996. Inbreeding and incompatibility in *Trichogramma nr. brassicae*: evidence and implications for quality control. *Ent. Exp. Appl.* 78: 283-290.
- Wensch, D.L. 1993. Evolutionary flexibility through haploid males or how chance favors the prepared genome, pp. 118-149. In D.L. Wensch and M.A. Ebbert (Eds.), *Evolution and Diversity of Sex Ratio in Insects and Mites*. Chapman & Hall, New York.
- Wright, S. 1922. Coefficient of inbreeding and relationship. *Amer. Natural.* 56: 330-338.

Figure legends (Saito et al.)

Fig. 1. Design of maintaining inbreeding lineages and Experiment I. L1,, L6 are the lineages established by 6 virgin females randomly picked up from two sub-populations (B1 and B2) approximately 300 m apart. They were mated with different subpopulation males and used as GP generation of each lineage. P, F1, F2.... are the successive generations. Females italicized are under unfertilized (non-mated) conditions. Experiments II-IV were explained in Fig. 2 and in the text.

Fig. 2. Design of Experiments II, III and IV. F_t indicates t generation (t=0 is parental generation). Females italicized are under unfertilized (non-mated) conditions. Mc strain was the mixed strain of B1 and B2 sub-populations. The other details of the experiments are explained in the text.

Fig. 3. Parental inbreeding effect on the fecundity (fertilized oviposition) of the progeny females in Experiment II. Number of eggs laid for 10 days was corrected by environmental variance observed in outbreeding control. Corrected mean (circle or box) with \pm SD and linear regression line of each lineage are given. The scale of abscissa is extended 3 times from $f=0.5$ to 1.0.

Fig. 4. Parental inbreeding effect on the unfertilized oviposition of the progeny females in Experiment III. Number of eggs laid for 10 days was adjusted by environmental variance observed in outbreeding control. Corrected mean (circle or box) with \pm SD and linear regression line of each lineage are given. The scale of abscissa is extended 3 times from $f=0.5$ to 1.0.

Fig. 5. Indirect maternal effect of inbreeding on the early survival (egg to protonymph) rate of the progeny (experiment IV) grown from the cross between females of inbred lineages and Mc males (in experiment II). Survival rate transformed to arcsin-root was adjusted by environmental variance observed in outbreeding control. Corrected mean (circle or box) with \pm SD and linear regression line of each lineage are given. The scale of abscissa is extended 3 times from $f=0.5$ to 1.0.

Fig. 6. Results of cross experiments between a depressed lineage (L2) and a normal one (L5). The left shows fecundity of fertilized females produced by parental cross and the right shows that of unfertilized females. L2C2: offspring of L2female \times L2male; L5C5: those of L5female \times L5male; L2C5: those of L2female \times L5male; L5C2: those of L2 female \times L5male. In the left figure, $P < 0.001$ between characters "a" and "b"; in the right figure, $P < 0.0001$ between characters "a" and "b" (analyzed by Scheffe's *post hoc* test for multiple comparisons). There were no significant differences between the same characters. Numerals in the figure are numbers of replicates (offspring females).

Fig. 7. Results of backcross experiment using progeny from the cross experiment between L2 and L5 (see Fig. 4). Between the combinations linked like horizontal bars, there are significant differences at $P < 0.03$ (by Scheffe's *post hoc* test for multiple comparisons). Vertical bars are standard deviations. L2C5B2: offspring of (L2C5) female \times L2 male; L5C2B2: those of (L5C2) female \times L2 male; L2C5B5: those of (L2C5) female \times L5 male; L5C2B5: those of (L5C2) female \times L5 male; L2C2C2: those of (L2C2) female \times L2 male (depressed control); L5C5C5: those of (L5C) female \times L5 male (normal control). Numerals in

the figure are number of progeny females tested. Other details are the same as in Fig. 6.

Table 1. Result of Anova for regression of early survival rate of progeny of inbred parents on I -value in experiment I. $F = 1.084 - 1.971 * I; r = 0.173; R^2 = .03$

Source	<i>df</i>	Sum of square	Mean square	<i>F</i>	<i>P</i>
Regression	1	23.25	23.25	1.47	0.232
Residual	47	745.54	15.86		

Table 2. Ancova analysis with *f*-value as a covariate for 10-day fecundity (fertilized oviposition) of all lineages in experiment II.

Source	<i>df</i>	Sum of square	Mean square	<i>F</i>	<i>P</i>
<i>f</i> -value	1	343.19	343.19	31.62	<.0001
Lineage	5	56.26	11.25	1.04	.396
<i>f</i> -val. * Line.	5	89.47	17.89	1.65	.147
Residual	279	3028.23	10.85		

After eliminating the interaction (<i>f</i> -val. * Line.)					
<i>f</i> -value	1	342.10	342.10	31.16	<.0001
Lineage	5	750.05	150.01	13.67	<.0001
Residual	284	3117.70	10.98		

Table 3. Statistical test for the linear regression of fecundity (fertilized) of progeny female produced by inbred pairs on f -value for each lineage in experiment II. P is the significance level of sequential Bonferroni test.

Lineage	L1	L2	L3	L4	L5	L6
r	-0.40	-0.39	-0.48	-0.06	-0.18	-0.31
R^2	0.16	0.16	0.23	0.00	0.03	0.10
Anova						
df	1, 46	1, 44	1, 49	1, 45	1, 48	1, 47
F	8.60	8.07	14.99	0.17	1.57	5.16
P	<0.03	<0.03	<0.01	>0.5	>0.3	>0.05

Table 4. Ancova analysis with f -value as a covariate for 10-day fecundity (unfertilized oviposition) of all lineages in experiment III.

Source	<i>df</i>	Sum of square	Mean square	<i>F</i>	<i>P</i>
<i>f</i> -value	1	1.41	1.41	0.34	0.563
Lineage	5	9.86	1.97	0.47	0.800
<i>f</i> -val. * Line.	5	58.45	11.69	2.77	0.018
Residual	301	1268.82	4.22		

Table 5. Statistical test for the linear regression of unfertilized oviposition rate of progeny female produced by inbred pairs on F -value for each lineage in experiment III. P is the significance level of sequential Bonferroni test.

Lineage	L1	L2	L3	L4	L5	L6
r	-0.03	-0.40	0.01	0.21	-0.06	0.15
R^2	0.00	0.16	0.01	0.04	0.00	0.02
Anova						
df	1, 53	1, 46	1, 57	1, 50	1, 48	1, 47
F	0.04	8.74	0.00	2.29	0.19	1.08
P	>0.5	0.03	>0.5	>0.5	>0.5	>0.5

Table 6. Ancova analysis with f -value as a covariate for early survival rate of all lineages in experiment IV.

Source	<i>df</i>	Sum of square	Mean square	<i>F</i>	<i>P</i>
<i>f</i> -value	1	23.77	23.77	0.45	0.505
Lineage	5	326.98	65.40	1.23	0.300
<i>f</i> -val. * Line.	5	288.94	57.79	1.08	0.372
Residual	150	8001.97	53.35		
After eliminating the interaction (<i>f</i>-val. * Line.)					
<i>f</i> -value	1	20.83	20.83	0.39	0.534
Lineage	5	316.66	63.33	1.18	0.320
Residual	155	8290.92	53.49		

Table 7. Statistical test for the linear regression of early survival rate of progeny of experiment II females produced by inbred pairs on r -value for each lineage in experiment IV. P is the significance level of sequential Bonferroni test.

Lineage	L1	L2	L3	L4	L5	L6
r	0.25	-0.24	0.05	0.20	-0.33	-0.33
R^2	0.06	0.06	0.00	0.04	0.00	0.11
Anova						
df	1, 26	1, 25	1, 25	1, 25	1, 24	1, 25
F	1.66	1.51	0.07	1.06	0.02	3.05
P	>0.5	>0.5	>0.5	>0.5	>0.5	>0.4

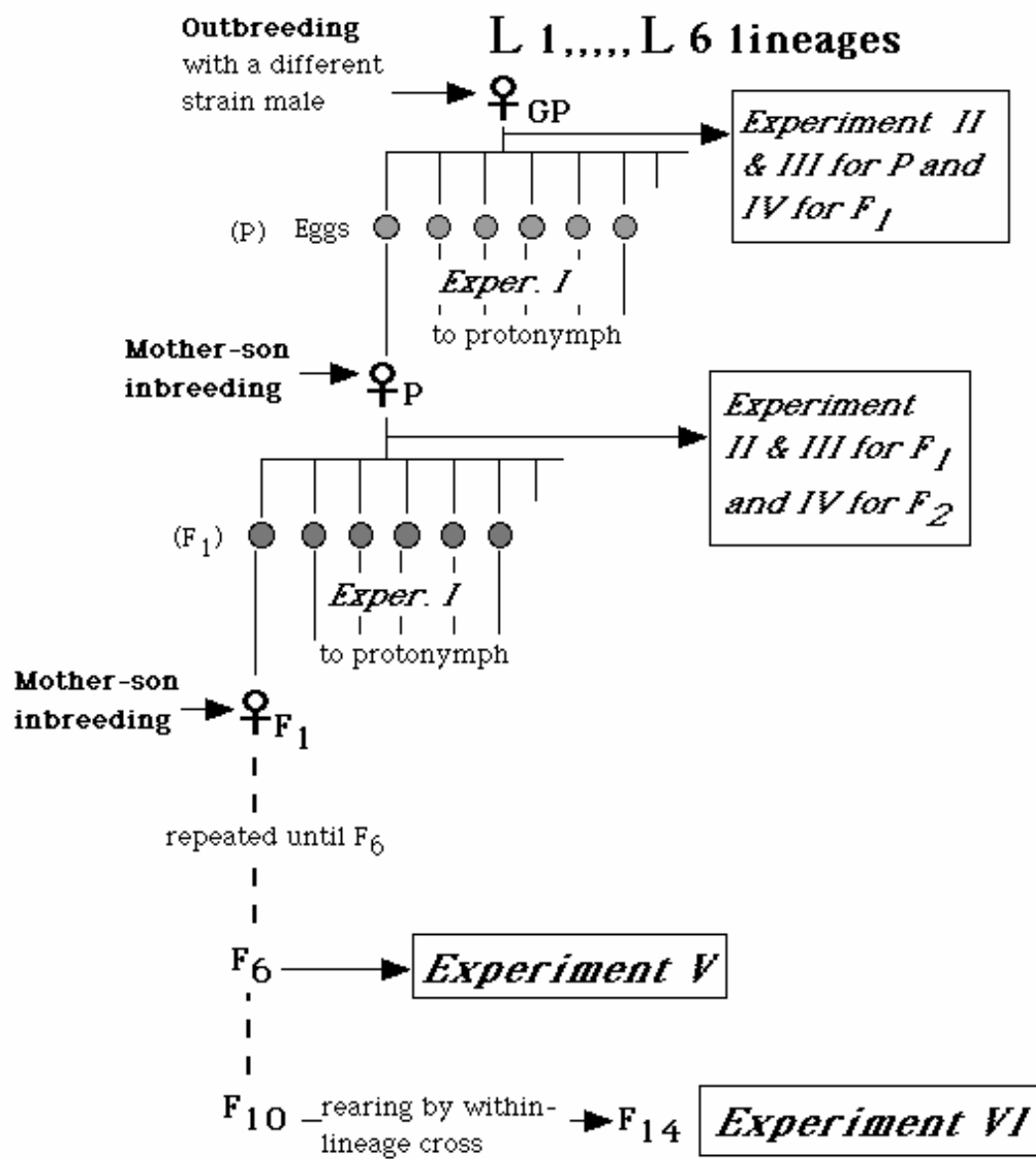

Saito et al. Fig. 1

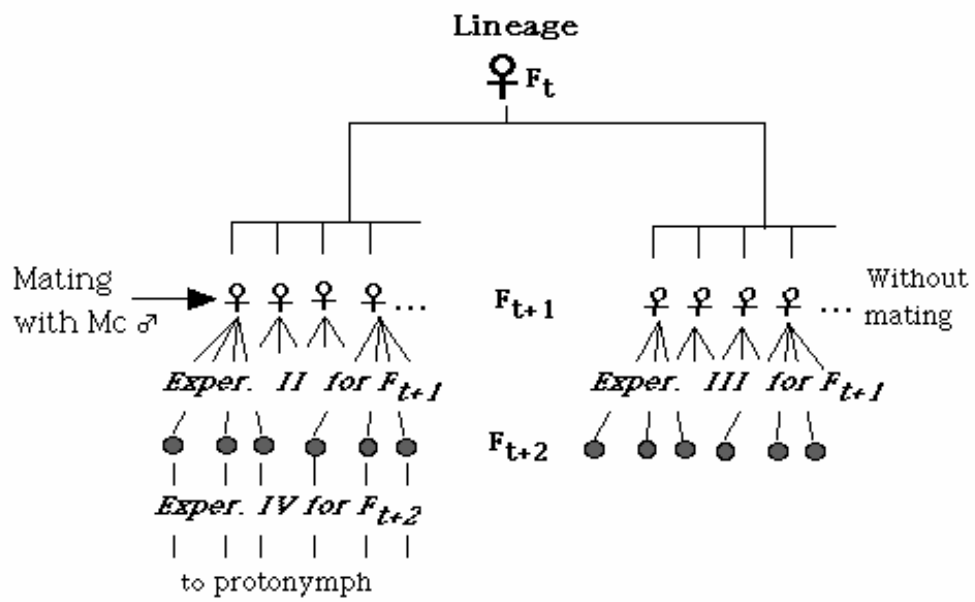

Saito et al. Fig. 2

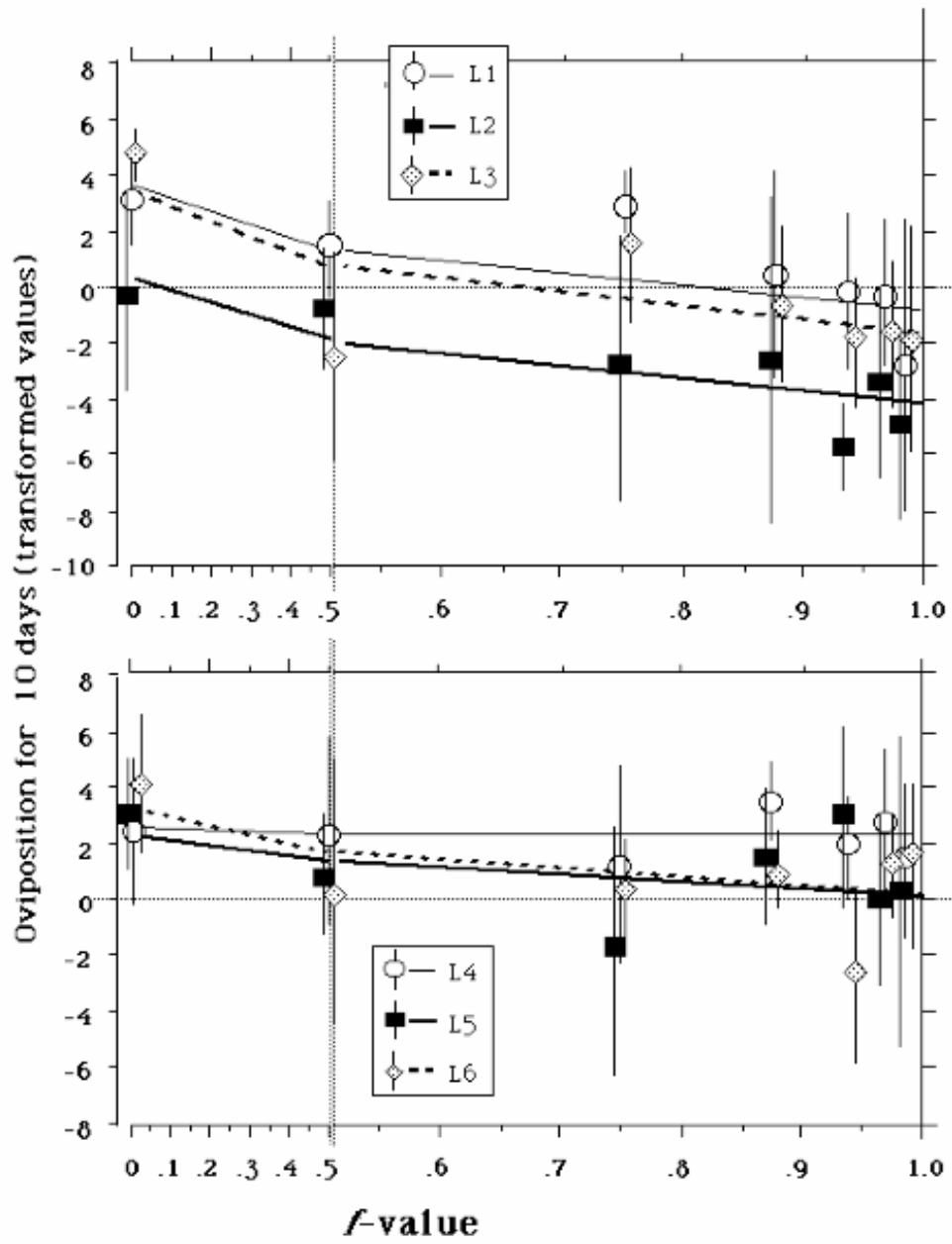

Saito et al. Fig.8

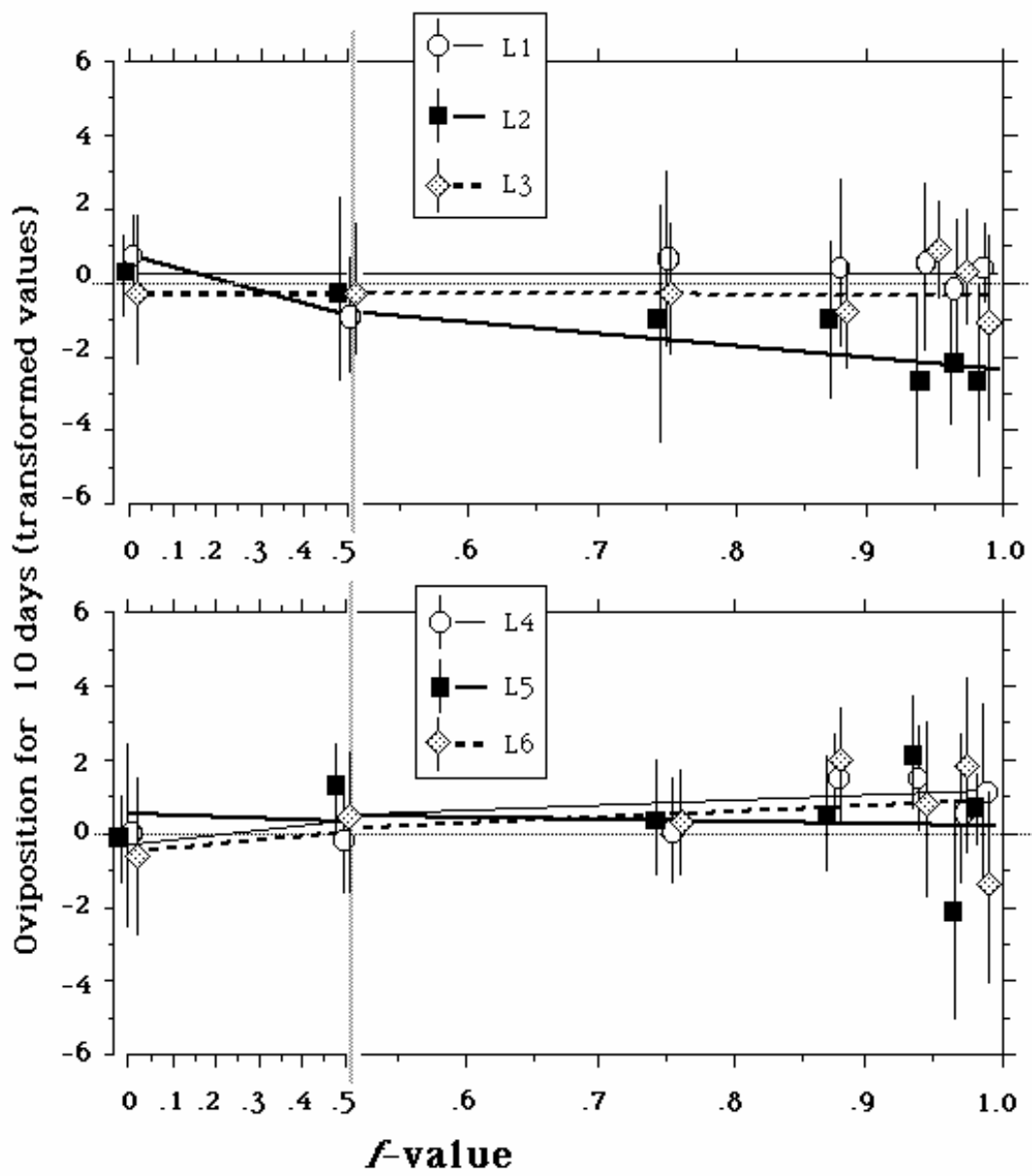

Saito et al. Fig. 4

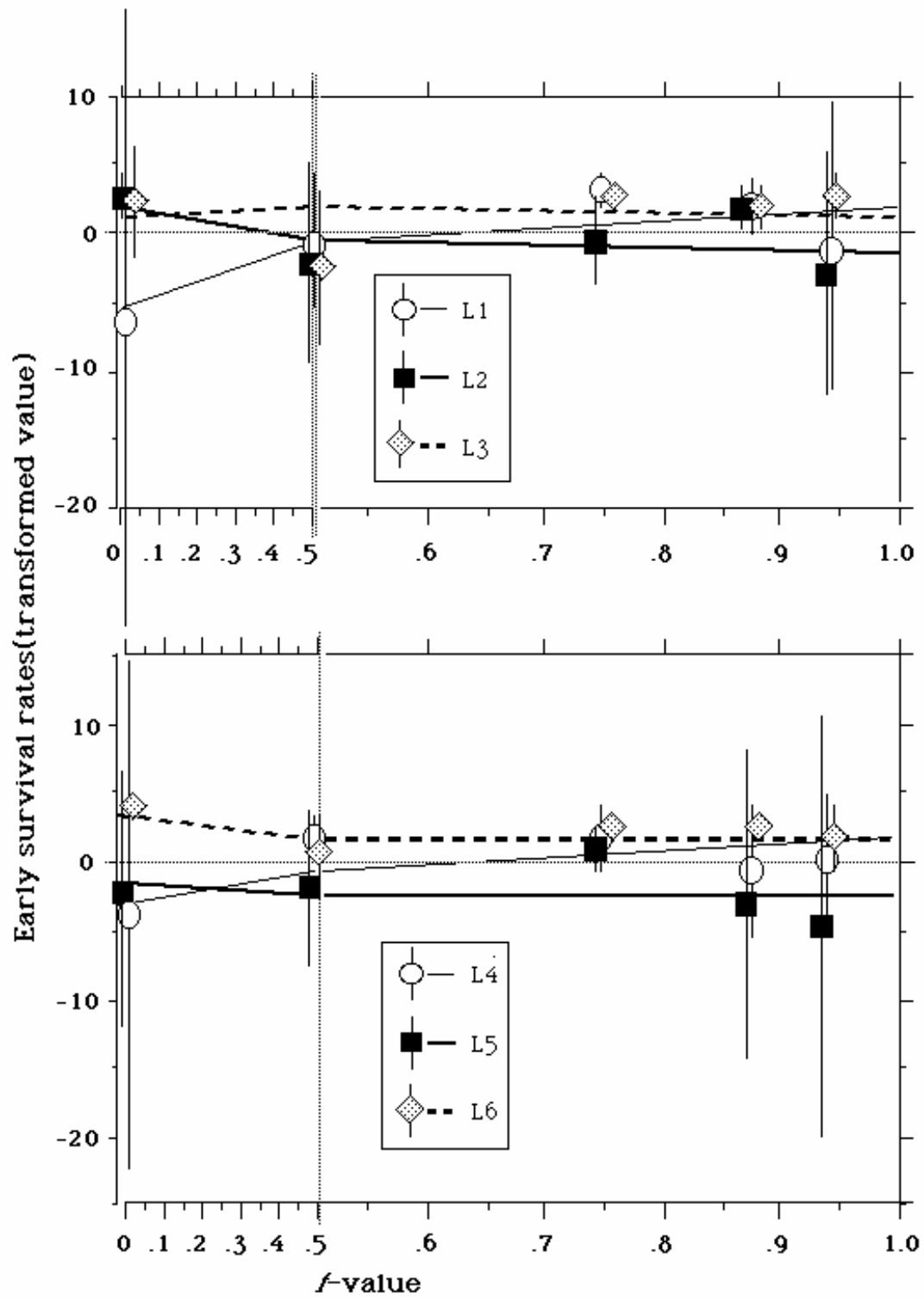

Salto et al. Fig.5

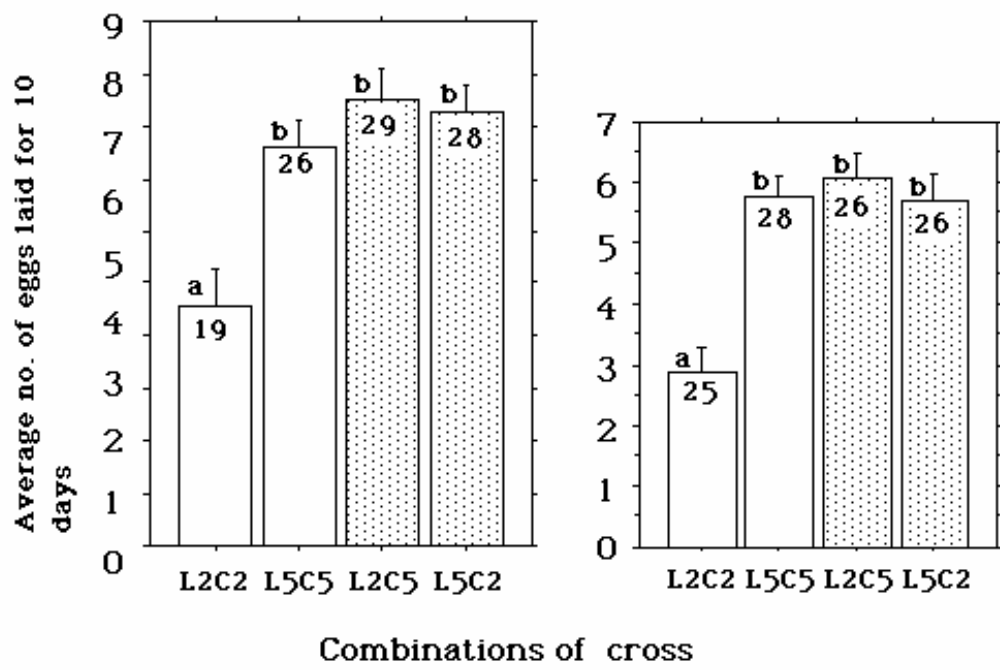

Saito et al. Fig.6

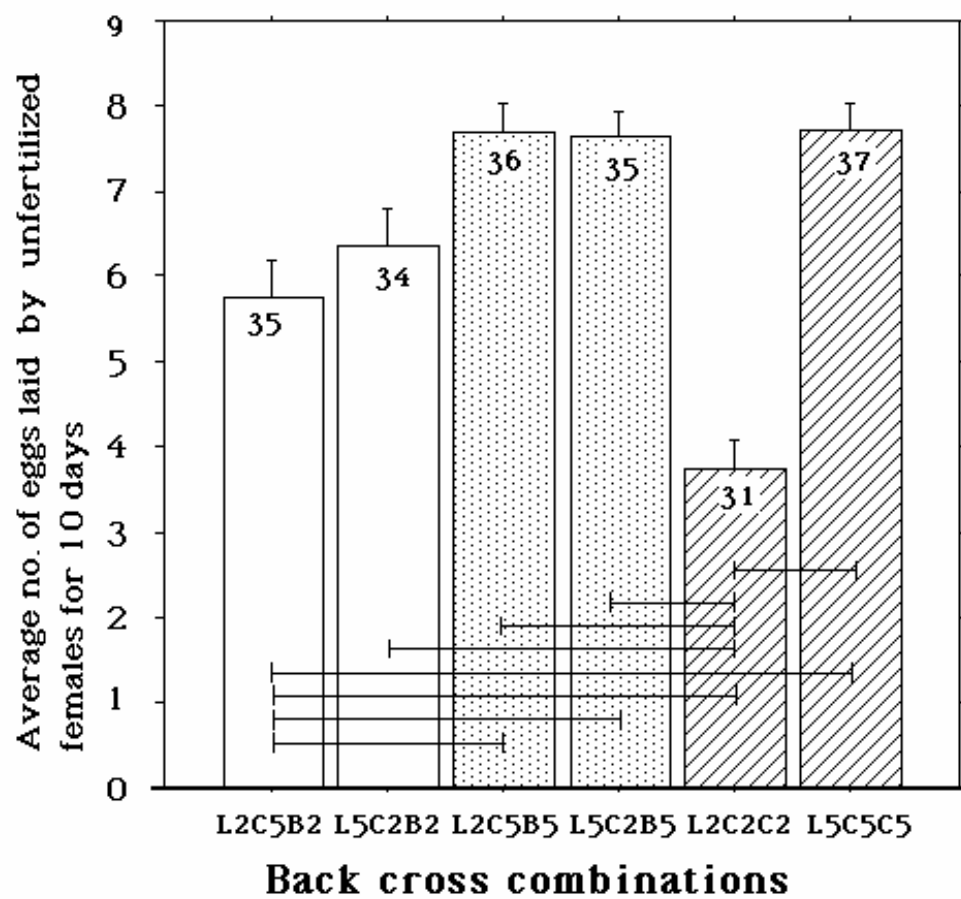

Seito et al. Fig.7