



# HOKKAIDO UNIVERSITY

Title	Properties of a GaAs Single Electron Path Switching Node Device Using a Single Quantum Dot for Hexagonal BDD Quantum Circuits
Author(s)	Nakamura, Tatsuya; Abe, Yuji; Kasai, Seiya et al.
Description	THE SEVENTH INTERNATIONAL CONFERENCE ON NEW PHENOMENA IN MESOSCOPIC STRUCTURES & THE FIFTH INTERNATIONAL CONFERENCE ON SURFACES AND INTERFACES OF MESOSCOPIC DEVICES (27 November--2 December 2005, Maui, Hawaii, USA)
Citation	Journal of Physics: Conference Series, 38, 104-107 <a href="https://doi.org/10.1088/1742-6596/38/1/026">https://doi.org/10.1088/1742-6596/38/1/026</a>
Issue Date	2006
Doc URL	<a href="https://hdl.handle.net/2115/10195">https://hdl.handle.net/2115/10195</a>
Type	journal article
File Information	NPMSnakamuraRev.pdf



# Properties of a GaAs Single Electron Path Switching Node Device Using a Single Quantum Dot for Hexagonal BDD Quantum Circuits

Tatsuya Nakamura, Yuji Abe, Seiya Kasai, Hideki Hasegawa and Tamotsu Hashizume

Research Center for Integrated Quantum Electronics and Graduate School of Information Science and Technology, Hokkaido University, North 13, West 8, Sapporo 060-8628, Japan

E-mail: nakamura@rciqe.hokudai.ac.jp

**Abstract.** A new single electron (SE) binary-decision diagram (BDD) node device having a single quantum dot connected to three nanowire branches through tunnel barriers was fabricated using etched AlGaAs/GaAs nanowires and nanometer-sized Schottky wrap gates (WPGs), and their operation was characterized experimentally, for the hexagonal BDD quantum circuit. Fabricated devices showed clear and steep single electron pass switching by applying only an input voltage signal, which was completely different from switching properties in the previous SE BDD node devices composed of two single electron switches. As the possible switching mechanism, the correlation between the probabilities of tunnelling through a single quantum dot in exit branches was discussed.

## 1. Introduction

Intensive efforts have been made to realize ultra-low-power and ultra-high-density logic LSIs using quantum nanodevices such as single electron transistors (SETs). However, it is very difficult to implement the conventional logic gate architecture, which is used in the present LSIs, with quantum nanodevices due to small gain, small current drive, and poor threshold voltage control. To overcome these problems, we have proposed a hexagonal binary decision diagram (BDD) quantum circuit architecture [1,2] and have fabricated various digital circuits, mainly utilizing quantum wire (QWR) based switches [3].

In this paper, we investigate basic properties of a new GaAs single electron (SE) BDD node device having a single quantum dot as a possible key node device for the hexagonal BDD quantum logic LSIs.

## 2. Concept of hexagonal BDD quantum circuits and single electron node device

The basic concept of the hexagonal BDD quantum circuit is shown in **figure 1**. The logic architecture of the circuit is the binary-decision diagram, BDD, where a logic function is represented by a directed graph [4,5]. The graph has a root, terminal-1, terminal-0, and node devices. A node device has one entry and two exit branches and its function is to select one of the exit branches for an information messenger coming from the entry branch, according to logic input, 0 or 1. The hexagonal layout of the graph enables high-density integration of the node devices. As shown in **figure 1**, the circuit does not include direct input-output connection, then voltage gain and large current drivability of the node

devices are not required. Here, for low power operation of the circuit with low current, a single or a few electrons are used as the messenger, and they are controlled precisely utilizing SE transport.

To realize SE-based hexagonal BDD circuits, a new SE node device, which is called as a node-switch-type device, was investigated. Its schematic illustration is shown in **figure 2(a)**. The basic structure has been already proposed [2]. In this study, its operation was characterized in more detail. The device has three nanowire-branches with a quantum dot (QD) at their junction node. The QD is isolated from each branch by a tunnel barrier formed by a nanometer-sized wrap gate (WPG) as shown in **figure 2(b)**. Basically, for path switching, complimentary gate voltages are applied to WPGs on the two exit branches, keeping the entry WPG voltage constant. As compared with a previous SE node device having two single electron switches at each branch, called a branch-switch-type device, the present node-switch-type device has simpler and more sophisticated structure. Here, T-junction structure was used instead of Y-junction for simplicity of fabrication and operation.

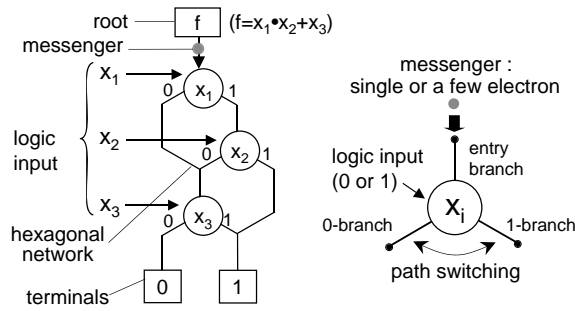

**Figure 1.** Basic concept of hexagonal BDD quantum circuit.

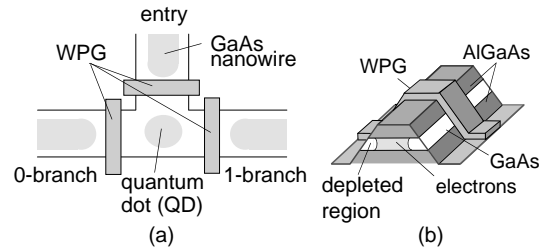

**Figure 2.** (a) Design of node-switch-type BDD SE node device and (b) WPG structure.

### 3. Experimental

The WPG-based SE BDD node device was fabricated on a T-branch GaAs nanowire structure formed on an AlGaAs/GaAs heterostructure wafer using electron beam (EB) lithography and wet chemical etching. After formation of Ge/Au/Ni Ohmic contacts for roots and terminals, 110 nm-length Cr/Au Schottky wrap gates were formed by the EB lithography, metal deposition and lift-off process. Conductance through each exit branch and path switching characteristics of the fabricated device was measured at 1.6 K.

### 4. Result and discussion

A secondary electron microscope (SEM) image of a fabricated SE node device is shown in **figure 3**. Each WPG-controlled nanowire branch operated as a conventional field effect transistor (FET) with good gate control characteristics from 1.6 K to room temperature. At 1.6 K, each exit branch showed clear conductance oscillation as shown in **figures 4** with the measurement setup shown in the top of the figure. In these measurements, only the WPG voltage on the exit branch was swept with keeping the other WPG voltages constant. The conductance oscillations maintained up to 20 K. The temperature dependence of the width and height of the conductance oscillation peaks indicated that the transport is controlled by the single-electron resonant tunnelling [5].

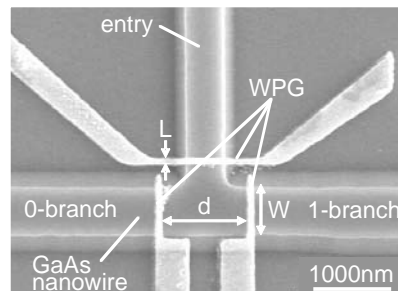

**Figure 3.** An SEM image of a fabricated SE node device.  $W = 630$  nm,  $L = 110$  nm,  $d = 1100$ nm.

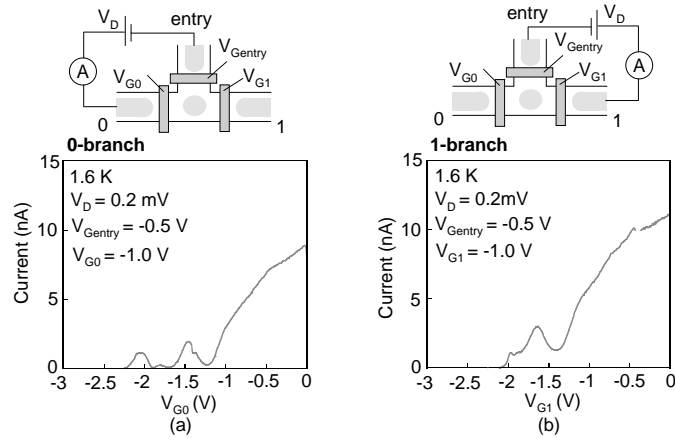
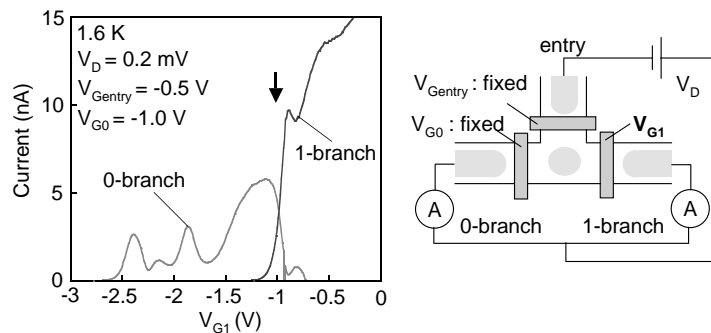

**Figure 4.** Conductance oscillations through each exit branch.

**Figure 5** shows the path switching characteristic of the fabricated device at 1.6 K with its measurement circuit. Here, both exit branch currents are plotted as a function of 1-branch WPG voltage,  $V_{G1}$ . It was found that the path of the current switched with keeping conductance oscillations, which confirmed that single electron path switching took place in this device. The notable characteristic is that the path switching occurred by sweeping only  $V_{G1}$ , even when the entry and 0-branch WPG voltages,  $V_{G0}$  and  $V_{Gentry}$ , respectively, were fixed. This operation is completely different from that in the branch-switch-type SE and QWR node devices where two complementary-input voltages were required for path switching [3]. In addition, the path switching took place only once by changing  $V_{G0}$  as indicated by an arrow in **figure 5**, which is also different from the operation in the SE node devices utilizing phase shift of conductance oscillations in two SE switches on exit branches [7]. Furthermore, the slope of the current-voltage curves around the cross point in this switching was steeper than that expected from the curves for single-path conductance measurements in **figure 4**. For example, in **figure 4**, the voltage difference between conductance peak and valley,  $\Delta V$ , was 0.26 V, although  $\Delta V$  at the current cross point in **figure 5** was 0.19 V.

Path switching characteristics were also measured by changing the entry WPG voltage,  $V_{Gentry}$ , and results are shown in **figure 6**. With decreasing  $V_{Gentry}$ , the 0-branch current-voltage curve was shifted toward positive, although the 1-branch current hardly shifted. It was also found that the voltage at current cross point kept almost constant, even changing  $V_{Gentry}$  from -0.2 V to -0.8 V. We also measured path switching characteristics by changing the 0-branch WPG voltage,  $V_{G0}$ , and in this case the current cross point was shifted toward positive slightly by decrease of  $V_{G0}$ . Then, the entry and exit branch WPGs were found to play different roles in this device.

The path switching mechanism in the present device seems complicated as compared with those in the other-type SE node devices. One of possible mechanisms for the observed unique path switching properties is that WPGs on exit branches change not only an individual tunnel barrier height and width, but also the distribution of electron wave functions in the dot that also affect on the tunnel barriers



**Figure 5.** Path switching characteristic of the fabricated node-switch type SE node device. The arrow indicates a pass switching bias point for exit electrons.

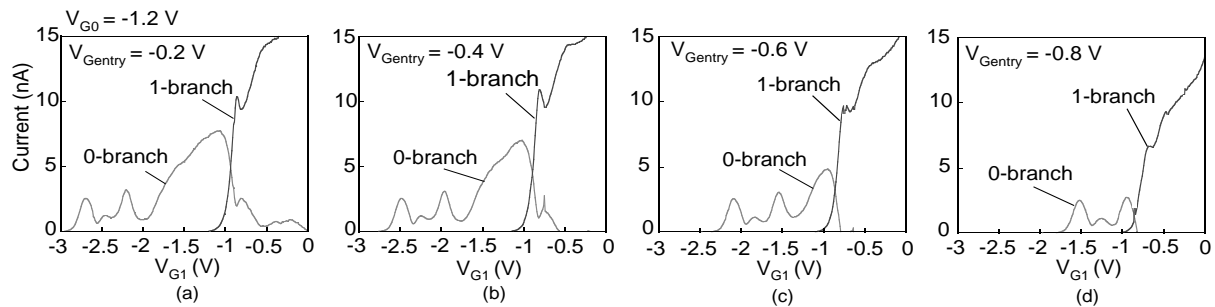

**Figure 6.** Path switching characteristics for the entry WPG voltages from -0.2 V to -0.8 V.

each other. Hereby, the conductances in the exit branches have non-classical correlation, where the currents are determined by the Kirchhoff's law for individual tunnel resistance values.

The entry WPG voltage should change the dot size and potential, then the both exit conductance oscillations seem to be shifted by  $V_{\text{Gentry}}$ . However, experimental results showed that the current cross point voltage hardly depended on  $V_{\text{Gentry}}$ . This indicates that the path switching is controlled mostly by the balance between the tunneling probabilities in the two exit branches.

The steep path switching in the present node-switch-type device as shown in **figure 5** also cannot be explained by the change of individual tunnel probability on each exit branch. Taking into account that all branches are connected to the same dot, the WPG voltage at the exit branch affects the whole SE transport in this system. If the 1-branch WPG voltage becomes negative, the electron distribution in the dot should skew to the 0-branch side, as well as increasing the 1-branch tunneling barrier height and width. Then, the tunneling probability in the 0-branch increases at the same time, even when only the 1-branch WPG is swept. In such manner, sharing the single dot in this device seems to bring non-classical correlation of the transport between the two exit branches, which is never seen in the branch-switch-type device. Although further investigation is necessary to completely understand this interesting switching mechanism, from the viewpoint of the steep path switching characteristic shows a good prospect for a new low-power switching operation of the present SE node device.

## 5. Conclusion

The new SE BDD node device having a single quantum dot connected to three nanowire branches through tunnel barriers was fabricated using etched AlGaAs/GaAs nanowires and nanometer-sized WPGs and their operation was characterized experimentally, for a hexagonal BDD quantum circuit. Fabricated devices showed clear and steep single electron pass switching by applying only an input voltage signal, which was completely different from switching properties in the previous SE BDD node devices composed of two single electron switches. As the possible switching mechanism, the correlation between the tunnel probabilities in exit branches through a single quantum dot was discussed.

## Acknowledgement

This work was partly supported by 21st Century COE program "Meme-Media Technology Approach to the R&D of Next-Generation ITs" in Hokkaido University and Grant-in-Aid for Young Scientists (A) (#17686028) from MEXT, Japan, and FY2004 Indust. Tech. Res. Grant Prog. from NEDO, Japan.

## References

- [1] Hasegawa H and Kasai S 2001 *Physica E* **11** 149
- [2] Kasai S and Hasegawa H 2002 *IEEE Electron Device Lett.* **23** 446
- [3] Kasai S, Yumoto M and Hasegawa H 2003 *Solid-State Electron.* **47** 199
- [4] Akers S B 1978 *IEEE Trans. Compt.* **C-27** 509
- [5] Asashi N, Akazawa M and Amemiya Y 1997 *IEEE Trans. Electron Devices* **44** 1109
- [6] Kasai S and Hasegawa H 2001 *Springer Proceedings in Physics ICPS-25 issue*, Part II, p. 1817
- [7] Nakajima F, Miyoshi Y, Motohisa J and Fukui T 2003 *Appl. Phys. Lett.* **83** 2680