



HOKKAIDO UNIVERSITY

Title	Studies on Potato Leaf-roll Virus
Author(s)	KOJIMA, Makoto
Citation	Journal of the Faculty of Agriculture, Hokkaido University, 57(4), 368-430
Issue Date	1974-09
Doc URL	https://hdl.handle.net/2115/12887
Type	departmental bulletin paper
File Information	57(4)_p368-430.pdf



STUDIES ON POTATO LEAF-ROLL VIRUS*

Makoto KOJIMA

(Department of Botany, Faculty of Agriculture
Hokkaido University, Sapporo, Japan)

Received Nov. 16, 1973

Contents

I. Introduction	369
II. Materials and methods	370
III. Mechanical inoculation of the virus	372
A. Mechanical inoculation of green peach aphid, <i>Myzus persicae</i>	372
B. Mechanical inoculation of aphid, <i>Aulacorthum solani</i>	374
C. Discussion and brief conclusions	376
IV. Some properties of the virus in the crude sap	377
A. Longevity <i>in vitro</i>	378
B. Dilution end point	378
C. Thermal inactivation point	378
D. Infectivity of frozen plant tissues	380
E. The effect of freezing and thawing of crude sap	380
F. Infectivity of pellets obtained by low-speed centrifuging	380
G. Infectivity of pellets obtained by high-speed centrifuging	382
H. Discussion and brief conclusions	383
V. Clarification and concentration	385
A. Clarification with chloroform	385
B. Clarification with a mixture of chloroform and <i>n</i> -butanol	386
C. Adsorption with a mixture of charcoal and Celite	386
D. Concentration by high-speed centrifugation	388
E. Discussion and brief conclusions	390
VI. Fractionation of clarified sap	391
A. Column chromatography	391
B. Sucrose density-gradient centrifugation	394
C. Discussion and brief conclusions	399
VII. Purification	400
A. Establishment of purification procedure	400
B. Morphology of purified PLRV	403

* This paper comprises part of a thesis submitted to Hokkaido University in partial fulfilment of the requirements for the degree of Doctor of Agriculture.

C.	Biological purity	404
D.	Effects of magnesium ion	405
E.	Purification of the virus from root tissues	406
F.	Attempts to simplify the concentrating procedure of clarified sap	406
G.	Discussion and brief conclusions	408
VIII.	Intracellular localization of the virus within plant host	410
A.	Experimental procedure	410
B.	Results	411
C.	Discussion and brief conclusions	412
IX.	General discussion	413
X.	Summary	420
XI.	References	422
XII.	Plates	

I. Introduction

Leaf-roll is the most prevalent and serious of the potato virus diseases and causes heavy damage in many districts over the world every year. In the beginning of this century, the causal agent of this disease was considered to be a virus based on the results obtained by grafting (QUANJER *et al.*, 1916). Subsequently, it was recognized that the agent was transmitted by an aphid vector (BOTJES, 1920; SCHUITZ and FOISON, 1921). In Japan, the disease was first mentioned by Hori (1920), but experiments on the transmission of the virus through the tubers, by grafting, juice inoculation and aphid vectors were first reported by KASAI (1922).

To date about 40 plant viruses are known to be transmitted persistently by aphid vectors (KENNEDY *et al.*, 1962; GIBBS, 1969). Potato leaf-roll virus (PLRV) is one of the most extensively studied. Although many studies on the transmission of the virus were done after 1922, there was little information on the nature of the virus, due to the lack of a bioassay method because it could not be transmitted from plant to plant by sap inoculation. In 1955, Heinze attempted to inject the aphid vector, and advocated the application of the technique to the study of persistent aphid-borne plant viruses. Subsequently, many workers confirmed the usefulness of his technique in experiments on aphid-borne plant viruses. PLRV was tested for infectivity by the bioassay method using extracts from infected plants or viruliferous aphids (DAY, 1955; STEGWEE and PONSEN, 1958; MURAYAMA and KOJIMA, 1963, 1965). Two trends of research on PLRV appeared, one of them research concerning the relationship between virus and vector, especially, virus multiplication in the vector, and another research on the

characterization of the virus. This investigation is along the latter lines and utilizes recent developments of purification techniques in addition to the application of the bioassay method. Some physical properties, isolation and purification of PLRV from plants, and the virus localization in plant tissues, will be described. This investigation was conducted over period of 10 years from 1961 to 1970 at Department of Botany, Faculty of Agriculture, Hokkaido University, Sapporo, Japan.

This investigation was supported in part by grants from the Hokkaido Science Foundation, Science Foundation of the Ministry of Education and the Matsunaga Science Foundation.

Grateful acknowledgement is made to Prof. Daiki MURAYAMA, Department of Botany, Faculty of Agriculture, Hokkaido University, for his guidance and suggestion throughout the experiments. Sincere appreciation is expressed to Assis. Prof. Eishiro SHIKATA, Department of Botany, Faculty of Agriculture, Hokkaido University, for his training and assistance throughout the experiments. The author wishes to acknowledge his indebtedness to Prof. EMER. of Hokkaido University, Teikichi FUKUSHI, and Prof. Koji HIRATA, Niigata University, for their personal interest and encouragement during the investigations. The author also thanks Dr. MYRON K. Brakke, University of Nebraska, Lincoln, Nebraska, U.S.A, for his suggestions during the preparation of this manuscript. Thanks are also due to Prof. Naoji SUZUKI, Kobe University, Dr. Ikuo KIMURA, late Dr. Tadashi KODAMA, Institute for Plant Virus Research, Chiba and Dr. Tatsuo YOKOYAMA, Institute for Fermentation, Osaka, for their advice and kind help during some of experiments concerning purification. The author is indebted to Assis. Prof. Kikuo SHIBATA, Niigata University, for his advice on rearing of aphids. Thanks are also due to Dr. Nobuyuki OSHIMA, Institute for Plant Virus Research, Mr. Rinzo SATO, Hokkaido Agricultural Experiment Station, and Mr. Shoichiro TAKAHASHI, Institute for Tuberculosis, Hokkaido University, for their kind help in using the electron microscope. Sincere appreciation is expressed to the members of Department of Botany, Faculty of Agriculture, Hokkaido University.

II. Materials and methods

Virus source: The virus used in this study was isolated from the sprouts of diseased potato tubers from the Agricultural Co-operative Association in Kameda, Hokkaido. The PLRV isolate was cultured in *Physalis floridana* RYDB. plants, which showed the distinct symptoms after inoculation with viruliferous aphids. The top leaf of *P. floridana* first showed

a chlorosis 7–10 days after inoculation. Thereafter a chlorosis between the veins occurred in lower leaves which became leathery and were slightly rolled. The inoculated plants were somewhat stunted.

Plant cultivation: *P. floridana* plants were usually used as test plants (KIRKPATRICK, 1948). Seeds of this plant were sown on vermiculite, and seedlings were transplanted to 10 cm pots when the second or third leaves were developed. Seedlings of plants for virus cultivation or aphid rearing were transplanted to 12 cm pots. Plants were grown in a glass house from 1961 to 1966 and in a temperature controlled green house (26°C) from 1967 to 1970.

Aphid vectors and their rearing: The green peach aphid *Myzus persicae* SULZ. (green clone) was used as a vector, but *Aulacorthum solani* KALTENBACH was also used in some experiments. Green peach aphids were reared on radish (*Raphanus sativus* L.) or Chinese cabbage (*Brassica peitsai* BAILEY), and *A. solani* on *Rumex obtusifolius* plants within insect cages in a green house. The buds from tulip bulbs were also used as the host for both aphids in the laboratory during the winter season (SHIBATA, 1962). All experiments were conducted with apterous adult aphids, which were removed by means of a hair brush.

Aphid-injection method: Injection procedures were carried out under

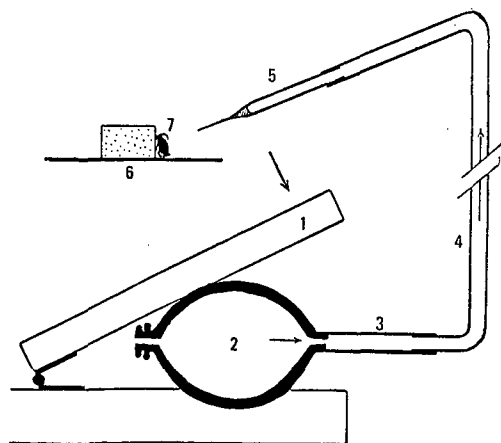

1. pushing plate; 2. rubber bulb;
3. rubber tube; 4. vinyl resin tube;
5. glass needle; 6. insect holder;
7. aphid

Figure 1. Schematic sketch of aphid-injection apparatus.

a binocular microscope ($\times 25$ or 40) in a cold room or at room temperature. Aphids anesthetized with carbon dioxide were kept in an insect-holder on the microscope stage. The needle was inserted as gently as possible into the abdomen through the intersegmental membrane. Two methods for injection were employed. The injection apparatus used for studies of rice dwarf virus (FUKUSHI and KIMURA, 1959; KIMURA and FUKUSHI, 1960) was used in some early experiments. Another apparatus used in later experiments is shown in Fig. 1. Inoculum within a glass needle was forced into the aphid body by pressing

the rubber bulb by foot. A capillary was twice drawn from a hard glass tube, 6 mm in diameter, in the flame of a Bunsen burner, and the tip of needle was made on a micro-forge. The tip of capillary, 10 to 30 μ in diameter, was then cut with a razor blade to make it sharp.

Inoculation feeding by the injected aphids: The injected aphids were placed in a petri-dish until they recovered from the anesthesia and were transferred to the test plants immediately or after rearing on immune plants overnight. Inoculation feedings were done within small insect cages in a green house. After exposing test plants to the injected aphids for 3 to 4 days, the aphids were removed with a hair brush. Then the plants were sprayed with the insecticide (Metasystox-S) and kept in a green house at least for one month.

Preparation of inoculum: Inoculum for aphid-injection was usually prepared in a cold room (4°C), unless mentioned otherwise. Low speed centrifugation was carried out in Kubota KT-65 centrifuge and high speed centrifugation in the Hitachi 40 P ultracentrifuge. Further details will be mentioned in the text.

Other equipments: Spectrophotometric measurements were made with a Hitachi EPU-2 A photometer. The virus specimens were observed with a JEM-5 Y electron microscope (80 KV). Ultrathin section were cut by a Porter-Blum MT-1 ultramicrotome equipped with glass knives.

III. Mechanical inoculation of the virus

Potato leaf-roll virus (PLRV), one of the circulative aphid transmitted viruses, can not be transmitted to plants by mechanical inoculation. For studies on leafhopper-borne plant viruses, a mechanical inoculation by insect-injection was developed in 1933 (STOREY, 1933). HEINZE (1955) first successfully applied the insect-injection technique to the aphid-borne plant viruses. Thereafter several workers have succeeded in transmitting PLRV by this technique (DAY, 1955; HARRISON, 1958; STEGWEE and PONSEN, 1958; DAY and ZAITLIN, 1959; STEGWEE and PETERS, 1963, 1965). The present author confirmed that the aphid vectors, when injected with the extracts from the diseased plants and homogenates or blood from viruliferous aphids, were capable of transmitting the virus to healthy plants (MURAYAMA and KOJIMA, 1963).

A. Mechanical inoculation of green peach aphid, *Myzus persicae*

1. Use of the extract from diseased potato plants as the inoculum

To prepare the liquid extracts, sprouts from diseased potato tubers were

ground with buffer solution (1/30 M phosphate buffer or 0.8% NaCl) in a mortar. Subsequently the juices were squeezed through double layers of gauze and were centrifuged at low speed. The supernatant fluids were assayed for infectivity by injection. As shown in Table 1, positive results were obtained in only two out of 7 experiments.

The upper parts of the test plants showing symptoms were grafted onto healthy *P. floridana* plants. Infection was confirmed, when the stock showed distinct symptoms. On the other hand, the 30 check plants that were fed with the aphids taken from the same stock culture and without injection, showed no symptoms.

2. Use of the extract from infected *P. floridana* plants as the inoculum

The next 3 experiments were carried out using the extracts from infected *P. floridana* plants (2-5 g) inoculated by green peach aphids that had acquired virus from diseased *Datura stramonium* plants.

Leaves of infected *P. floridana* plants were ground with 1/30 M phosphate buffer (pH 7.0) or physiological saline and the expressed saps were

TABLE 1. Transmission of PLRV by green peach aphids *Myzus persicae* injected with extracts from infected plants and viruliferous aphids.

Inoculum	Experiment	Number of aphids injected	Number of survivors ^a	Transmission ^b
<i>Solanum tuberosum</i>	1	30	19	0/30
	2	30	21	0/30
	3	30	27	2/30
	4	30	10	0/10*
	5	40	5	0/10
	6	90	63	2/30
	7	120	17	0/17*
<i>Physalis floridana</i>	1	90	44	1/30
	2	70	8	1/8*
	3	40	31	4/31*
<i>Myzus persicae</i>	1	30	19	2/30
	2	48	41	2/41*
	3	41	28	1/28*

a 24 hours after injection

b numerator: number of plants infected;

denominator: number of plants infested with injected aphids

* inoculation feeding 24 hours after injection

centrifuged at low speed. The resulting supernatant fluids were assayed for infectivity. All procedures were carried out in a cold room. Only 6 out of 69 test plants infested with the injected aphids showed symptoms in 3 experiments (Table 1).

3. Use of the homogenates from viruliferous aphids as the inoculum

Homogenates obtained from viruliferous green peach aphids which had been reared on diseased potato or *P. floridana* plants were used as inocula in the following experiments.

In *Exp. 1*, apterous aphids which had been reared on diseased potato plants were ground with 10 times the original volume of the phosphate buffer; the homogenates were centrifuged at 5,000 rpm for 30 minutes.

In the other 2 experiments, apterous aphids which had fed on infected *P. floridana* plants were ground with 40 times the original volume of the 0.8 per cent sodium chloride. The homogenates were centrifuged at 9,000 rpm for 8 minutes.

The supernatants in these 3 experiments were injected into virus-free green peach aphids which were kept on detached leaves of *P. floridana* or radish plants for 24 hours. All procedures were carried out at room temperature. As shown in Table 1, 5 out of 99 test plants showed symptoms.

4. Use of the blood of viruliferous aphids as the inoculum

Apterous aphids which had fed on diseased potato plants for 5 days were anesthetized with CO₂ gas. Their blood was removed with a glass needle, and then was immediately injected into one or two virus-free aphids with same needle. Each of the injected acceptor and donor aphids was placed separately in a petri-dish until it recovered from the anesthesia and was then transferred to a test plant. As shown in Table 2, five out of 13 donor aphids transmitted the virus and 4 out of 19 acceptor (injected) aphids became inoculative. The results also showed that the ability to transmit the virus seemed to vary considerably with individual aphids (in either donor or acceptor). In general, aphids which acquired the virus by feeding on infected plants for 5 days had a high inoculativity. However, the transmission rate of the donors in this experiment was low, i. e., 38 per cent. It might be due to high mortality caused by injury during removal of blood from the donors.

B. Mechanical inoculation of the aphid, *Aulacorthum solani*

1. Use of the extract from infected *P. floridana* plants as the inoculum

A. solani has been known as a vector of this virus in Japan (FUKUSHI,

TABLE 2. Infectivity of hemolymph from viruliferous aphids *M. persicae*

Insect No.	Infectivity	
	Donor	Acceptor
1	○	○
2	○	●
3	●	○ ○
4	○	○
5	●	○ ●
6	○	○ ○
7	○	●
8	●	○ ○
9	●	○ ○
10	○	○ ○
11	●	○ ●
12	○	○
13	○	○
Total	5/13	4/19

● infection ○ no infection

1946; MURAYAMA and KOJIMA, 1964 a, 1965). *A. solani* transmitted the virus after they had been injected with the expressed juice of infected *P. floridana* plants that had been clarified by centrifugation for 30 minutes at 3,000 rpm. Experiments were repeated twice. In *Exp. 1*, thirty aphids were injected with the extract from 10 g of fresh leaves of infected *P. floridana* plants and kept on detached leaves of *Rumex obtusifolius* for 24 hours at room temperature before the inoculation feeding. Only one out of 19 survivors became inoculative (Table 3). On the other hand, in *Exp. 2*, five out of 25 plants infested with the injected aphids showed symptoms (Table 3).

2. Use of the homogenates from viruliferous aphids as the inoculum

Apterous, adult aphids (183 mg), fed on diseased potato plants, were ground in a mortar with 25 times their weight of phosphate buffer. Subsequently the supernatant obtained by centrifuging the homogenate at 3,000 rpm for 15 minutes was assayed for infectivity. Fifty five injected aphids were kept on detached leaves of *R. obtusifolius* plant for 24 hours at room temperature and then were transferred to test plants. As shown in Table 3, two out of 29 test plants infested individually with injected aphids, and 3 out of 10 plants infested with 2 aphids per plant, showed symptoms.

TABLE 3. Transmission of PLRV by *Aulacorthum solani* injected with extracts from infected plants and viruliferous aphids

Inoculum	Experiment	Number of aphids injected	Number of survivors ^a	Transmission ^b
<i>Physalis floridana</i>	1	30	19	1/19
	2	50	25	5/25
<i>Aulacorthum solani</i>	3	55	49	2/29 3/10 ^c

a 24 hours after injection

b numerator: number of plants infected;
denominator: number of plants infested with injected aphids

c 2 aphids per test plant

C. Discussion and brief conclusions

Although the potato leaf-roll disease has been studied for many years, little information on the causal entity is available as compared with any other virus causing a major disease of potato plants. One of the reasons is the lack of a suitable quantitative method for assaying virus activity. HEINZE (1955), first introduced successfully the insect-injection method, which had been developed in studies of some leafhopper-or planthopper-borne plant viruses, to the studies of the aphid-borne persistent plant viruses. Thereafter several workers succeeded in the mechanical transmission of PLRV by means of the aphid-injection method. So far, extracts from the infected plants and homogenates and hemolymph from the viruliferous aphids have been used by several workers as inocula, but there have been no reports to compare efficiency of those preparations as inocula. For an example of use of the extract from plant tissues, one may cite HEINZE (1955), who first recognized the infectivity in supernatant obtained by low-speed centrifugation of extracts from *D. stramonium*, *P. floridana* and *S. tuberosum* plants infected with PLRV. DAY and ZAITLIN (1958) also found that green peach aphids injected with concentrated extracts from infected *P. floridana* plants, transmitted the virus to test plants even though at low frequency. PETERS (1967 b) also reported positive results using crude plant extracts. He, however, did not succeed in detecting the infectivity in preparation concentrated by differential centrifugation. For example of use of the hemolymph from viruliferous aphids, one may again cite, HEINZE (1955), who pointed out that hemolymph as inoculum was less toxic to aphids than were plant extracts. DAY (1955) and STEGWEE and

PONSEN (1958) confirmed that green peach aphids injected with hemolymph from viruliferous aphids became inoculative. On the other hand, DAY (1955) first used homogenates of viruliferous aphids as inoculum. He found that the pellet obtained by centrifuging homogenates from viruliferous aphids at 100,000 *g* for 30 minutes was infective. HARRISON (1958) and PETERS (1967 b) also confirmed that the homogenates of viruliferous aphids were infective and a good source of virus for injection to aphid vectors. Although the honeydew from viruliferous aphids was known as good inoculum of pea enation mosaic virus (RICHARDSON and SYLVESTER, 1965), no attempts to use honeydew were reported in studies on PLRV.

In this experiment, the present author also succeeded in transmitting the virus by injecting green peach aphids with extracts from diseased plants and homogenates or blood from viruliferous aphids, *M. persicae*. However, the frequency of transmission by the injected aphids was too low to compare with that of inocula from different sources and prepared in different ways. *A. solani* also became inoculative after injection with extracts from infected plants and viruliferous aphids. This aphid species, however, does not seem to be a suitable vector for injection in spite of its large size because of its high mortality. Furthermore, *P. floridana* seedlings (test plants) infested with *A. solani* aphids frequently withered. Hence, green peach aphids, *M. persicae* were used as vector for injection-assay in the following experiments.

Since HARRISON (1958) reported that *M. persicae* seldom transmitted the virus within 20 hours after injection, the injected aphids in many cases in this work were kept on detached leaves for 24 hours at room temperature and then transferred to test plants. However, a few injected aphids transmitted the virus within 24 hours after injection when the aphids were transferred to test plants immediately after injection. STEGWEE (1960) suggested that the presence of PLRV in the blood could be demonstrated about eight hours after acquisition feeding and that after the first demonstration of the virus in the blood another eight to sixteen hours were required before the aphid was able to transmit the virus. Accordingly, when the virus preparations are injected into the abdomen of aphids, the aphids may become inoculative 8 to 16 hours after injection.

IV. Some properties of the virus in the crude sap

Although several workers have succeeded in transmitting PLRV by the aphid-injection method, few attempts have been made to study extensively the characteristics of the virus. It appeared that some properties of the

virus in crude sap should be investigated before attempting purification of the virus from infected plant tissues. Experiments were conducted on the stability and concentration of the virus in sap. Experimental results on the longevity *in vitro*, the dilution end point, the thermal inactivation point, the effect of freezing of plant tissue or sap, and the centrifugation needed to pellet the virus, are described in this Chapter.

A. Longevity *in vitro*

Fresh leaves (10 g) of infected *P. floridana* plants were ground in 10 ml of 0.3 M phosphate buffer (pH 7.0). Crude sap was centrifuged at 3,000 rpm for 30 minutes and then the supernatant fluids were stored at 2°C. The samples were assayed for infectivity 1, 3, 5 and 10 days after preparation. As a control, a part of the preparation was injected immediately to aphid vectors. As shown in Table 4, the virus appeared to retain activity for 5 days.

TABLE 4. Longevity of PLRV *in vitro*

Storage time	Number of aphids injected	Number of survivors ^a	Infectivity ^b
control ^c	50	29	3/29
1 day	50	38	3/38
3 days	60	53	5/20
5 days	50	29	2/29
10 days	50	11	0/11

a 24 hours after injection

b numerator: number of plants infected;

denominator: number of plants infested with injected aphids

c assayed immediately after preparing inoculum

B. Dilution end point

The juices from infected *P. floridana* plants (10 g) were clarified by centrifuging at 3,000 rpm for 30 minutes and were diluted to 10^{-1} , 10^{-2} , 10^{-3} and 10^{-4} with 0.3 M phosphate buffer. Each preparation was assayed for infectivity. The results indicated that the dilution end point of the virus lay between 10^{-3} and 10^{-4} (Table 5).

C. Thermal inactivation point

The extracts from infected *P. floridana* plants (5–25 g) were clarified by centrifuging at 10,000 rpm for 30 minutes and then put into glass tubes (90 × 6 mm) which were plugged with rubber stoppers at both ends and immersed in a water bath at the desired temperature for 10 minutes. After

TABLE 5. Dilution end point of PLRV

Dilution	Number of aphids injected	Number of survivors ^a	Infectivity ^b
10 ⁻¹	60	56	5/56
10 ⁻²	40	35	4/35
10 ⁻³	110	99	4/59 ^c
10 ⁻⁴	70	62	0/20 ^d
control ^e	40	35	3/35

a 24 hours after injection

b numerator: number of plants infected;
denominator: number of plants infested with injected aphids

c 2 aphids per plant

d 3 aphids per plant

e undiluted

TABLE 6. Thermal inactivation point of PLRV

Experiment	Temperature	Number of aphids injected	Number of survivors ^a	Infectivity ^b
1	30°C	50	27	5/27
	40	50	36	9/36
	50	50	39	9/39
	control ^c	50	25	9/25
2	50	50	46	4/30
	60	50	43	8/30
	70	50	45	5/30
3	50	40	19	3/19
	70	40	20	3/20
	80	40	12	0/12
	control	40	23	3/23
4	70	60	55	2/27
	80	60	45	0/21
	control	60	47	3/24
5	50	50	45	4/45
	80	100	74	0/74
	control	90	62	8/62

a 24 hours after injection

b numerator: number of plants infected;
denominator: number of plants infested with injected aphids

c not heated

cooling in cold tap water, the preparations were immediately assayed for infectivity. Before assaying the aliquots, they were sometimes centrifuged at 3,000 rpm for 10 minutes to remove the heat-denatured materials. As shown in Table 6, the thermal inactivation point of the virus appeared to lie between 70° and 80°C.

D. Infectivity of frozen plant tissues

The infected leaves of *P. floridana* were frozen at -20°C and used as source of inocula in this experiment. The frozen tissues (5-10 g) were ground with 0.3 M phosphate buffer (pH 7.0) at room temperature after storage for 1/2, 1, 3, and 7 days, 1 and 3 months, and 1 year, respectively. The crude saps were clarified by centrifuging at 3,000 rpm for 30 minutes and then the supernatant fluids were assayed for infectivity. As shown in Table 7, infectivity was retained in the frozen plant tissues at least for three months.

TABLE 7. Infectivity of frozen plant tissues

Storage time	Number of aphids injected	Number of survivors ^a	Infectivity ^b
12 hours	40	14	4/14
24 hours	50	40	7/40
3 days	50	24	4/24
7 days	50	30	3/30
1 month	50	33	5/33
3 months	60	52	6/10
1 year	50	22	0/22

a 24 hours after injection

b numerator: plants infested; denominator: plants infested

E. The effect of freezing and thawing of crude sap

The supernatant fluids clarified by centrifuging extracts from infected *P. floridana* plants (10 g) at 3,000 rpm for 15 minutes were frozen at -20°C for 24 hours. They were thawed gradually at room temperature and then were recentrifuged at 3,000 rpm for 30 minutes. The resulting supernatant fluids were assayed for infectivity. It was found that the juices frozen at -20°C for 24 hours retained their infectivity, viz. 4 out of 25 test plants infested individually by aphids injected with treated inocula became infected.

F. Infectivity of pellets obtained by low-speed centrifuging

Fresh leaves (10 g) of infected *P. floridana* plants were ground in 10 ml of 0.3 M phosphate buffer (pH 7.0) and the crude sap was centrifuged at

3,000 rpm for 30 minutes. As shown in Fig. 2, the resulting supernatant was centrifuged at 5,000 rpm (1,600g) for 30 minutes and then subsequently the supernatant was again centrifuged at 10,000 rpm (6,500g) for 30 minutes in a 40 P rotor. Each pellet was resuspended in 10 ml of phosphate buffer and then clarified by centrifuging at 3,000 rpm for 30 minutes. Each resulting supernatant (S, P₅, P₁₀ and S₁₀) was assayed for infectivity. The experiment was repeated three times. As shown in Table 8, it was found that S₁₀ (supernatant obtained by centrifuging at 10,000 rpm) was associated with the infectivity, although P₅ and P₁₀ (pellets obtained by centrifuging at 5,000 rpm and 10,000 rpm, respectively) were also infectious except in *Expt. 3*. These results suggested that PLRV particles could not precipitated intrinsically in the neutral condition by centrifuging at 10,000 rpm (6,500g) for 30 minutes, and also that a considerable amount of the virus was lost during low-speed centrifugation.

G. Infectivity of pellets obtained by high-speed centrifugation

To find the time and speed of centrifugation required to pellet PLRV, the following experiments were done. Crude sap from 10 g of infected *P. floridana* plants was clarified by the procedure described previously. As shown in Fig. 3, the resulting supernatant was centrifuged at 10,000 rpm (6,500g) for 60 minutes and then at 20,000 rpm (26,000g) for 60 minutes

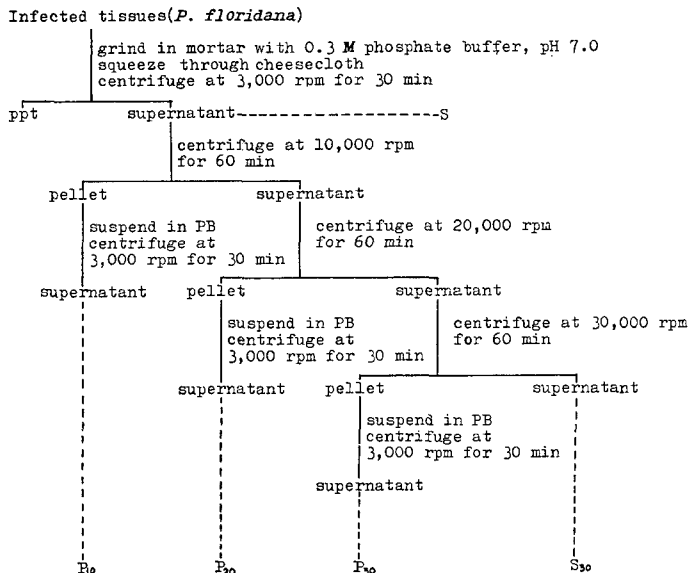

Figure 3. Procedure of high-speed centrifugation test.

TABLE 9. Infectivity of each fraction after high-speed centrifugation

Experiment	Fraction ^a	Number of aphids injected	Number of survivors ^b	Infectivity ^c
1	S	40	22	5/22
	P ₁₀	40	37	3/37
	P ₂₀	40	38	2/38
	P ₃₀	40	38	2/38
	S ₃₀	40	36	2/36
2	S	30	18	1/18
	P ₁₀	30	25	2/25
	P ₂₀	30	24	1/24
	P ₃₀	30	26	7/26
	S ₃₀	30	3	1/3
3	P ₁₀	50	41	2/15
	P ₂₀	50	49	2/15
	P ₃₀	50	37	4/15
	S ₃₀	50	44	1/15

a S: supernatant obtained by centrifugation for 30 min at 3,000 rpm; P₁₀: pellet obtained by centrifugation for 60 min at 10,000 rpm; P₂₀: pellet obtained by centrifugation for 60 min at 20,000 rpm; P₃₀: pellet obtained by centrifugation for 60 min at 30,000 rpm; S₃₀: supernatant obtained by centrifugation for 60 min at 30,000 rpm

b 24 hours after injection

c numerator: number of plants infected;
denominator: number of plants infested with injected aphids

in a 40 P rotor. The resulting supernatant was centrifuged at 30,000 rpm (58,000*g*) for 60 minutes. Each pellet was resuspended in 10 ml of phosphate buffer and clarified by centrifuging at 3,000 rpm for 30 minutes. The resulting supernatants (P₁₀, P₂₀, P₃₀ and S₃₀) were assayed for infectivity. Same experiments were repeated three times. On the basis of the results obtained here, it appears that a small amount of infectious materials still remained in the supernatant fraction (S₃₀) after being centrifuged at 30,000 rpm (58,000*g*) for 60 minutes (Table 9). Each pellet obtained by centrifuging below 58,000*g* for 60 minutes was also associated with infectivity, suggesting that infectious materials considerably sedimented to the pellet.

H. Discussion and brief conclusions

The stability and some physical properties *in vitro* of PLRV were

mentioned in this Chapter. The results are considered to be of a restricted value, although the stability of the virus in crude preparations is important. The virus appeared to be still infectious after storing it at 2°C for 5 days. DAY and ZAITLIN (1958) reported that plant sap from the infected plants retained infectivity for 24 hours at 2°C. Conversely, infectivity in blood from the viruliferous aphids remained for 3 days at 2°C (MUELLER and ROSS, 1961). STEGWEE and PETERS (1961) reported that homogenates of the viruliferous aphids retained infectivity for 24 hours at 3°C and for 3 weeks at -16°C, respectively. PETERS (1967, b) reported that homogenates of the viruliferous aphids remained infectious for 5 days at 2°C when the virus was kept in phosphate buffer containing 0.006 *M* mercaptoethanol, but only for 12 hours at 25°C and for 4 hours at 37°C, respectively, when it was kept in phosphate buffer alone. On the basis of these results, it is necessary to extract the virus from plant materials as quickly as possible, and at low temperatures.

The dilution end point appeared to be between 10^{-3} and 10^{-4} , when plant sap was diluted with 0.3 *M* phosphate buffer. Similar results were reported for this virus in blood and homogenates of the viruliferous aphids (STEGWEE and PONSEN, 1958; PETERS, 1967, b).

The virus in crude plant sap appeared to be inactivated between 70°C and 80°C. PETERS (1967, b) reported similar results using homogenates of aphids. Similar results were reported for barley yellow dwarf virus, one of the aphid-borne persistent plant viruses (HEAGY and ROCHOW, 1965).

PLRV was tolerant to freezing of plant tissue and sap. This fact is very useful for storage of the virus source and purification of the virus.

PLRV in crude plant sap appeared to be rather stable, based on the data for stability.

It was found in these experiments that infectivity still remained in the supernatant fraction of extracts of the infected plants after being centrifuged at 30,000 rpm (58,000 *g*) for 60 minutes. DAY (1955) reported that the pellet obtained by centrifuging the extract from viruliferous aphids at 100,000 *g* for 30 minutes was associated with infectivity. However, he did not assay for infectivity in the supernatant fluid. STEGWEE and PETERS (1961) found that each pellet obtained by centrifuging homogenates of aphids at 6,500 *g*, 26,000 *g* and 105,000 *g* for 80 minutes, respectively, was infectious. PETERS (1967, b) also reported that no infectivity remained in the supernatant fraction of homogenates of the viruliferous aphids after being centrifuged at 100,000 *g* for 70 minutes. On the basis of these results, PLRV is considered to be a small particle.

V. Clarification and concentration

Several methods to clarify sap from plants infected with viruses are known (KODAMA, 1968). In this investigation, I tried clarification with organic solvents, which have been extensively applied to plant viruses. The method was combined with the adsorption in some experiments. To concentrate clarified sap, high speed-centrifugation was employed.

A. Clarification with chloroform

Infected plants (5–25 g) were extracted in 0.3 M phosphate buffer, pH 7.0. The maceration media contained the following: 0.01 M MgCl₂ (*Exp. 3*), 0.001 M EDTA (*Exp. 4*), 0.1% ascorbic acid (*Exp. 5*) and 0.001 M DIECA (*Exp. 6*). After centrifugation at 3,000 rpm for 30 minutes, chloroform was added to the supernatant fluid and stirred for 10 minutes. Chloroform was added at a concentration of 20% in *Exp. 5*, 25% in *Exp. 6* and 10% in other experiments. Emulsions were broken by centrifuging at 3,000 rpm for 30 minutes. The resulting supernatant fluid was concentrated by differential centrifugation (58,000 g for 90 minutes; 6,500 g for 30 minutes). All procedures were done in a cold room (4°C). Concentrated preparations were injected to green peach aphids for bioassay. After being kept on radish plants (immune) overnight, the injected aphids were transferred to test plants. Six experiments were done.

As shown in Table 10, the preparations treated with chloroform were infectious. The clearest preparation was obtained in the final experiment (*Exp. 6* in Table 10). It was brown with slight opalescence.

TABLE 10. Effect of chloroform on PLRV

Experiment ^a	Number of aphids injected ^b	Number of survivors ^c	Infectivity ^d
1	50	47	7/47
2	80	66	2/22
3	50	30	5/15
4	50	40	6/20
5	60	52	2/26
6	60	46	2/23

a emulsified with 10% chloroform (*Exp. 1–4*), 20% (*Exp. 5*) and 25% (*Exp. 6*), respectively

b number of aphids injected with each clarified aqueous phase

c 24 hours after injection

d numerator: number of plants infected;

denominator: number of plants infested with injected aphids

B. Clarification with a mixture of chloroform and *n*-butanol

Infected *P. floridana* plants (40–100 g) were triturated in 0.3 M phosphate buffer containing DIECA at a concentration of 0.001 M (*Exp. 1* and *2*) and 0.01 M (*Exp. 3*), except for *Exp. 4*. In *Exp. 4*, extraction was made in 0.05 M borate buffer (pH 7.0) containing 0.01 M DIECA. After low-speed centrifugation, a mixture of chloroform and *n*-butanol (1:1) was added to the supernatant fluid at a concentration of 20–25%, and stirred for 10 minutes. After the emulsion was broken by low-speed centrifugation, the aqueous phase was decanted and then concentrated by differential centrifugation. All procedures were conducted in a cold room. Four experiments were done. Extractions from healthy plants were done simultaneously in *Exp. 2* and *4*.

TABLE 11. Effect of a chloroform and *n*-butanol mixture on PLRV

Experiment ^a	Number of aphids injected ^b	Number of survivors ^c	Infectivity
1	60	47	2/23
2	60	52	3/26
3	50	32	4/32
4	66	38	6/22

a used *P. floridana* as virus source/emulsified with 20% chloroform and *n*-butanol (*Exp. 1* and *4*) and 25% (*Exp. 2* and *3*)

b number of aphids injected with each clarified aqueous phase

c 24 hours after injection

It was confirmed that the preparations clarified with a mixture of chloroform and *n*-butanol were infectious (Table 11). The final preparations appeared more clear than that with chloroform alone, which were a pale yellow color or transparent. The ultraviolet absorption spectrum showed that the preparation from PLRV-affected plants (*Exp. 3*) contained some nucleoproteins. Measured from the spectrum, a ratio of A₂₆₀/A₂₈₀ is 1.81 and A_{max} (260)/min (235) is 1.52. However, the concentrated preparation from healthy *P. floridana* plants by the same procedure, showed a similar UV-spectrum. Similar results were obtained from *Exp. 4*, in which borate buffer was used to macerate both infected and healthy plant tissues.

C. Adsorption with a mixture of charcoal and Celite

Infected *P. floridana* plants (25–50 g) were triturated in 0.1 M phosphate buffer (pH 7.0) containing 0.01 M DIECA. A mixture of charcoal and Celite

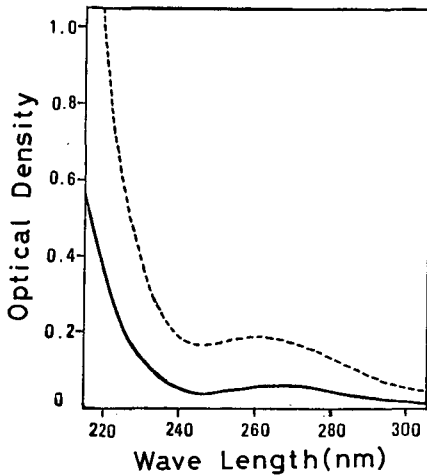

Figure 4. Ultraviolet absorption spectra of clarified preparations. Extracts from *P. floridana* plants were concentrated by differential centrifugation following filtration through a charcoal and Celite pad. The final pellets were resuspended in 0.01 *M* phosphate buffer. Solid and dotted curves represent preparation from infected and healthy plants, respectively.

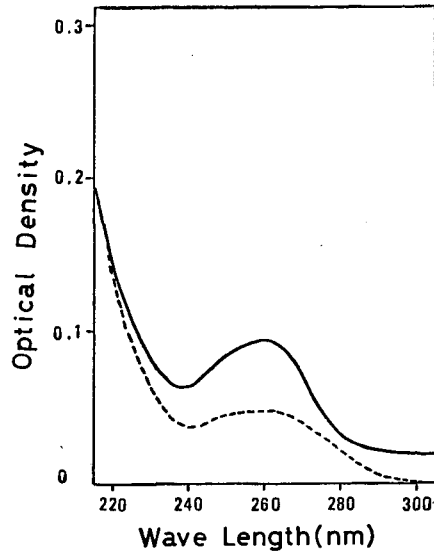

Figure 5. Ultraviolet absorption spectra of clarified preparations. Extracts from *P. floridana* plants were concentrated by differential centrifugation following centrifugation of mixtures in which charcoal and Celite were added to sap. The final pellet was resuspended in 0.01 *M* phosphate buffer. Solid and dotted curves represent preparations from infected and healthy plants, respectively.

(1:1) was added to expressed sap at a concentration of 10%. After stirring for 30 minutes, the mixed sap was clarified by either filtration through a Buchner funnel or centrifugation at 8,500 *g* for 30 minutes. In each case, the clarified sap was again treated with a mixture of chloroform and *n*-butanol, and then concentrated by differential centrifugation (65,000 *g* for 120 minutes; 8,500 *g* for 30 minutes). Each final preparation was compared spectrophotometrically with a healthy one.

An ultraviolet absorption spectrum of a 10-fold concentrated preparation which had been filtered through a Buchner funnel, is shown in Fig. 4. The preparation was not opalescent. Additionally, this one was not infectious. Fig. 5 shows a spectrum of a 10-fold concentrated preparation which had been clarified by centrifugation. Although the preparation from infected plants had a somewhat higher absorption than that of healthy one, it was not infectious.

2. Results

As shown in Table 12, each fraction was associated with infectivity, but the P₄₀ fraction (pellet obtained by centrifuging at 100,000*g* for 60 minutes) appeared to be more infectious than the others. Sometimes, the P_{40'} fraction (pellet obtained by again centrifuging at 100,000*g* for 180 minutes) was infectious. Conversely, specific particles with a uniform shape and size were not obvious in the electron microscope, although several kinds of particles were observed in each fraction.

Based on the data (Table 12), partial purification was attempted. Extraction and clarification from 40 g of leaves was done as described above. The aqueous phase was concentrated by differential centrifugation (100,000*g* for 90 minutes; 6,500*g* for 15 minutes). When the aphids injected with a final preparation (10-fold concentrated) were fed on test plants (4 aphids per plant), 4 out of 10 plants became infective. The preparation used as inoculum was diluted 5 times with 0.01 *M* phosphate buffer, and the ultraviolet absorption spectrum determined (Fig. 7). Another preparation

TABLE 12. Infectivity of each fraction after high-speed centrifugation using sap clarified by a chloroform and *n*-butanol mixture

Experiment	Fraction ^a	Number of aphids injected	Number of survivors ^b	Infectivity
1	P ₂₀	36	27	2/12
	P ₃₀	36	27	4/12
	P ₄₀	36	28	3/12
2	P ₂₀	30	25	1/10
	P ₃₀	30	28	2/10
	P ₄₀	30	27	4/10
3	P ₃₀	50	33	3/10
	P ₄₀	50	42	7/10
	P _{40'}	50	35	0/10
4	P ₃₀	50	42	4/10
	P ₄₀	50	34	6/10
	P _{40'}	50	46	2/10

- a P₂₀: pellet obtained by centrifugation for 60 min at 20,000 rpm;
 P₃₀: pellet obtained by centrifugation for 60 min at 30,000 rpm;
 P₄₀: pellet obtained by centrifugation for 60 min at 40,000 rpm;
 P_{40'}: pellet obtained by centrifugation for 180 min at 40,000 rpm
- b 24 hours after injection

was simultaneously made from healthy plants to compare with that from PLRV-infected ones. The spectra show that preparations from both infected and healthy plants had nucleoproteins. By the way, the absorbance ratio was as follows: $A_{260}/A_{280}=1.46$ in infected, $A_{260}/A_{280}=1.29$ in healthy; $A_{260}/A_{240}=1.18$ in infected, $A_{260}/A_{240}=1.24$ in healthy. Because the preparation from healthy plants obtained by this procedure contained some nucleoproteins, it appeared that majority of absorbance in the preparation from infected plants was due to normal cell constituents which sedimented at 100,000g. The amount of virus could not be exactly deduced from the spectrum. Electron microscopic examination suggested that the amount of virus isolated from plant materials was very small, i. e., no uniform particles were found in the preparation from infected plants.

E. Discussion and brief conclusions

It was considered that clarification and concentration were the important steps in purification procedures of viruses. Several methods to clarify plant saps were known, but among them a method of clarification with organic solvents was examined in this experiment (STEERE, 1959). Chloroform (SCHNEIDER, 1953) had not been applied for clarification of saps from plants infected with PLRV. In this experiment, it was confirmed that PLRV survived chloroform treatment and saps from *P. floridana* plants became fairly clear. To avoid oxidation of plant saps and to stabilize the virus in saps, $MgCl_2$ (BRAKKE, 1967), EDTA (LINDNER *et al.*, 1955), ascorbate and DIECA (FULTON, 1959) were added to the maceration media (phosphate buffer) before clarification with a chloroform solvent. Addition of DIECA was most effective. In addition, clarification by chloroform and *n*-butanol together (STEERE, 1956) was more effective than chloroform alone, for extracts in phosphate buffer containing DIECA. There was no noticeable difference when borate buffer, which

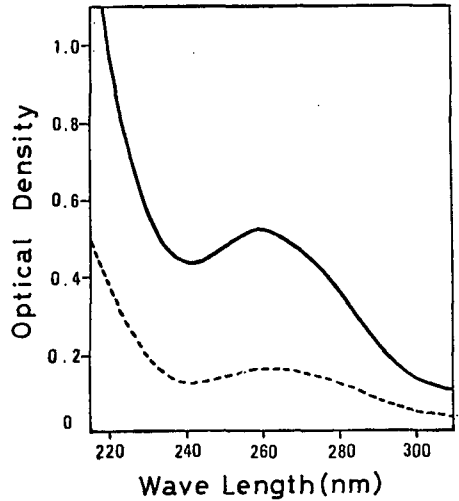

Figure 7. Ultraviolet absorption spectra of partially purified preparations. Solid curve represents preparation from PLRV-infected plants obtained by differential centrifugation following clarification with a chloroform and *n*-butanol mixture. The final pellet was resuspended in 0.01 M phosphate buffer. Dotted curve represents preparation from healthy plants obtained by same procedure.

prevents aggregation of some viruses (SHEPHERD and POUND, 1960; TOMLINSON, 1963), was used for maceration medium as a substitute for phosphate buffer.

Normal cell constituents were not completely removed, when a plant extract treated with a mixture of charcoal and Celite was filtered through a Buchner funnel (PRICE, 1946; CORBETT, 1961; CORBETT and ROBERTS, 1962; HARIHARASUBRAMANIAN, 1964) or centrifuged (GÁLVEZ, 1964), and then treated with chloroform and *n*-butanol.

High-speed centrifugation methods were employed to concentrate the virus in this experiment. Some experiments were conducted again to investigate the force of gravity needed to sediment the virus particles from clarified sap. It appeared that PLRV was sufficiently sedimented by centrifugation at 100,000 *g* for more than 60 minutes, although some of the virions were pelleted by centrifugation below 100,000 *g*.

It was shown by both electron micrographs and ultraviolet absorption spectra that the preparations partly purified by a procedure based on some results described above, contained a large amount of normal cell constituents, but, nevertheless, were highly infectious (MURAYAMA and KOJIMA, 1964 b). As the next step, it was necessary to separate the virus particles and cell constituents.

VI. Fractionation of clarified sap

Infectious preparations were obtained from PLRV-infected plant tissues by clarification with organic solvents followed by differential centrifugation (V Chapter). The ultraviolet spectrum indicated that the preparation obtained by the procedure described above contained normal cell constituents. Next it was necessary to separate the normal cell constituents and infectious agent. For this purpose, the author applied column chromatography with DEAE-cellulose (TOYODA *et al.*, 1965) and sucrose density-gradient centrifugation (BRAKKE, 1960).

A. Column chromatography

1. Experimental procedure

a) Conditioning of DEAE-cellulose column

Ten grams of DEAE-cellulose (BROWN Co., 0.93 meq/g) was washed with 0.5 *N* NaOH for 15 hours, and then with distilled water. The washed resin was placed in a column. The DEAE-cellulose column was washed with phosphate buffer until the pH of effluent fell to 7.0. The top of column was covered with a disk of filter paper to avoid disturbance of the surface.

b) Stepwise elution

The buffer-washed column (1 × 5 cm), to which a clarified and concentrated preparation had been added, was washed with stepwise increasing concentrations of NaCl in phosphate buffer. Each effluent was examined by measuring the optical density at 260 nm.

c) Linear gradient elution

The column, to which a clarified preparation had been added, was washed with 80 ml of phosphate buffer, and then with a linear gradient of NaCl from 0 to 1.0 M in phosphate buffer prepared with a mixing device of two 400 ml jars (PHILIPSON, 1967). The effluent was collected with a fraction collector and the optical density at 260 nm measured. Elution was done at room temperature.

2. Experimental results

a) Step-wise elution

Crude sap obtained from diseased *P. floridana* plants by grinding with 1/30 M phosphate buffer, pH 7.0, was clarified with chloroform, and was concentrated by differential centrifugation (58,000 g for 90 min; 6,500 g for 30 min). The column, to which 5 ml of clarified preparation had been added, was washed with 20 ml portions of 1/30 M phosphate buffer containing NaCl (from 0.1 to 1.0 M). The effluent was divided into 5 test tubes (4 ml per tube) for each NaCl concentration. Finally the column was washed with 20 ml of 0.5 N NaOH to elute acidic substances. The control preparation from healthy *P. floridana* plants was fractionated by the same procedure. Two identical chromatograms with maximum peaks at 0.6 M NaCl were obtained. Pigments were eluted by alkali.

TABLE 13. Infectivity of each fraction obtained by DEAE-cellulose column chromatography

Molarity of NaCl	Fraction number	Number of aphids injected	Number of survivors ^a	Infectivity
0.2	11-15	30	29	0/10
0.3	16-20	30	27	0/10
0.4	21-25	30	28	0/10
0.5	26-30	30	28	3/10
0.6	31-35	30	28	5/10
0.7	36-40	30	27	0/10
Unfractionated		30	27	1/10

a 24 hours after injection

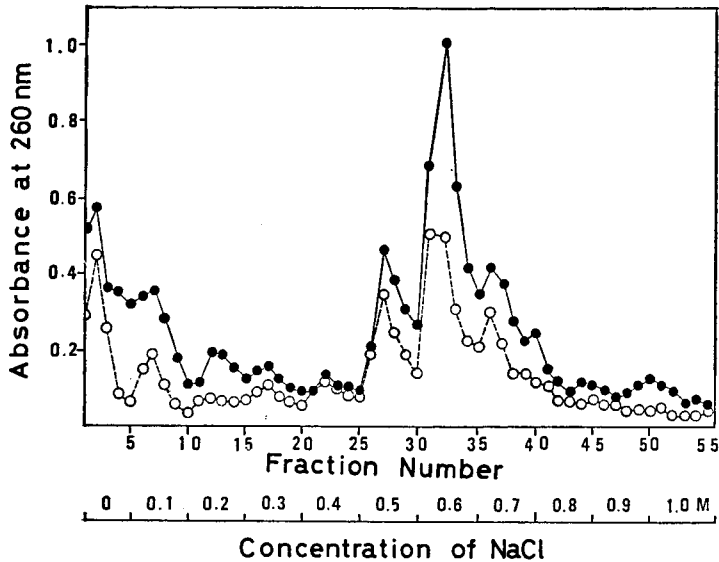

Figure 8. DEAE-cellulose column chromatogram of the preparations obtained from infected (closed circle) and healthy (open circle) plants. (step-wise elution)

After the combined effluents (corresponding to each NaCl concentration) were dialyzed against phosphate buffer overnight in a cold room, they were assayed by the aphid-injection method. It was confirmed that effluents corresponding to 0.5 M or 0.6 M NaCl contained some infectious agents (Table 13).

In another experiment, an extract obtained by grinding diseased *P. floridana* plants in 1/30 M phosphate buffer containing 0.01 M DIECA, was clarified with a mixture of chloroform and *n*-butanol, and was concentrated by differential centrifugation (65,000 *g* for 90 min; 8,500 *g* for 15 min). The column, to which 6 ml of the 10-fold concentrated preparation was added, was washed in the same manner as the experiment mentioned above despite varying the clarification procedure, the same chromatogram were obtained (Fig. 8). Three effluents fraction numbers 12 and 32 (corresponding to 0.2 M and 0.6 M NaCl, respectively), from the "infected" preparation, and 32 from the "healthy" preparation, were dialyzed against phosphate buffer, and assayed. Two out of 20 test plants infested by aphids injected with fraction number 32 from the "infected" preparation showed symptom.

b Linear gradient elution

An extract obtained from frozen *P. floridana* plants (100 g) by grinding

in 200 ml of 1/30 M phosphate buffer containing 0.01 M DIECA, was clarified with a mixture of chloroform and *n*-butanol, and was concentrated by differential centrifugation (65,000 *g* for 90 min; 8,500 *g* for 15 min.). The column, to which 5 ml of a 20-fold concentrated preparation was added, was washed with 80 ml of phosphate buffer, and then with a linear gradient of 0.2 M to 1.2 M NaCl in phosphate buffer. The optical density of each 4 ml of effluent was measured at 260 nm. A preparation from healthy *P. floridana* plants was fractionated by the same procedure. The linear gradient elution, which had three main peaks (P 1-P 3) and a smaller one (S), did not distinguish between the "infected" and the "healthy" preparations (Fig. 9). Five fractions from S and P 3 regions were collected and dialyzed against phosphate buffer and then assayed by aphid-injection. A small amount of the concentrated preparation (before addition to the DEAE-cellulose column) was also assayed. The infectious agent was not recovered from either the S or P 3 preparation, although 9 out of 20 test plants infested by aphids injected with a control preparation were infected.

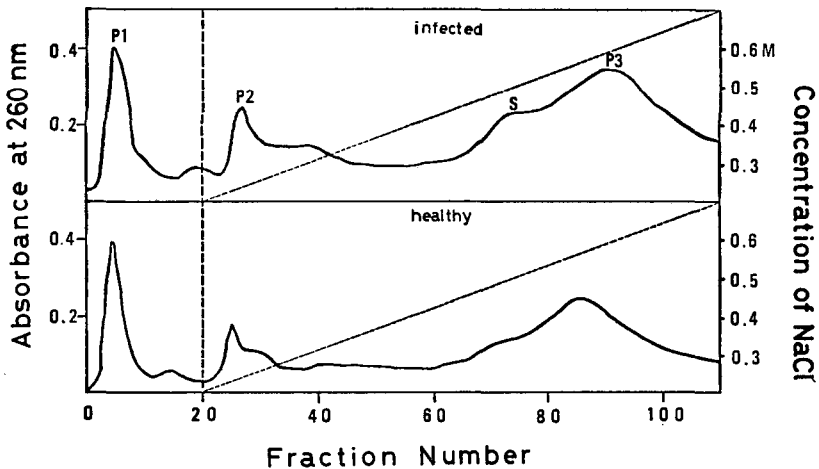

Figure 9. DEAE-cellulose column chromatogram of the preparations obtained from infected and healthy plants. (linear elution)

B. Sucrose density-gradient centrifugation

1. Spectrophotometric analysis

a) Experimental procedure

Rate zonal sucrose density-gradient columns consisted of descending layers (1, 1, 1, and 1 ml) of 10, 20, 30, and 40 per cent (w/v) sucrose dis-

solved in 0.01 *M* phosphate buffer, pH 7.4. The columns were allowed to stand at 4°C for 24 hours to obtain continuous gradients. Following storage, 0.5 or 1 ml samples were layered on the columns which were centrifuged in a precooled RPS 40 swinging bucket rotor. After centrifugation, the contents of the columns were collected by droplet fractionation. Each fraction was diluted to 4 ml and the optical density read at 260 nm.

b) Experimental results

Homogenates obtained from fresh leaves of diseased and healthy *P. floridana* plants in 0.1 *M* phosphate buffer, pH 7.4, were clarified with a chloroform and *n*-butanol mixture (1/4 volume), concentrated by differential centrifugation (82,000 *g* for 90 min ; 6,500 *g* for 15 min.). The sucrose columns, on which the concentrated preparation was layered, were centrifuged at 105,000 *g* for 180 minutes. The contents of the columns were divided into 20 tubes. The same UV absorption patterns, which contained 3 peaks, were obtained from both "infected" and "healthy" plants.

In the preparations obtained from the same procedures using 0.1 *M* phosphate buffer containing 0.1% ascorbate (*Exp. 2*) or 0.01 *M* DIECA (*Exp. 3*), also showed no difference in UV-absorbance pattern between the infected and healthy materials (Fig. 10).

For bioassays, three inocula, from combined fraction numbers 1-10, 11-25, and 26-40 were dialyzed overnight against phosphate buffer (0.01 *M*, pH 7.4), and injected into aphid vectors. A part (fraction 11-25) was associated with infectivity (Table 14), which was yet low. Infectivity of an unfractionated preparation, before layering onto a sucrose column, was also low, suggesting that the virus was lost during the first step in the purification procedure, the maceration in acidic media (phosphate buffer pH 6.0), although the extract was clarified effectively.

TABLE 14. Infectivity of each zone after sucrose density-gradient centrifugation (*Exp. 3*)

Fraction number	Number of aphids injected	Number of survivors ^a	Infectivity
1-10	50	42	0/5
11-25	50	37	1/5
26-40	50	30	0/5
Unfractionated	50	38	1/6

a 24 hours after injection

In another experiment (*Exp. 4*), extracts obtained from fresh leaves of infected plants in 0.1 M phosphate buffer, pH 7.4 containing 0.01 M DIECA, were clarified by a chloroform and *n*-butanol mixture, concentrated, and centrifuged at 120,000 *g* for 120 minutes on sucrose density gradient columns.

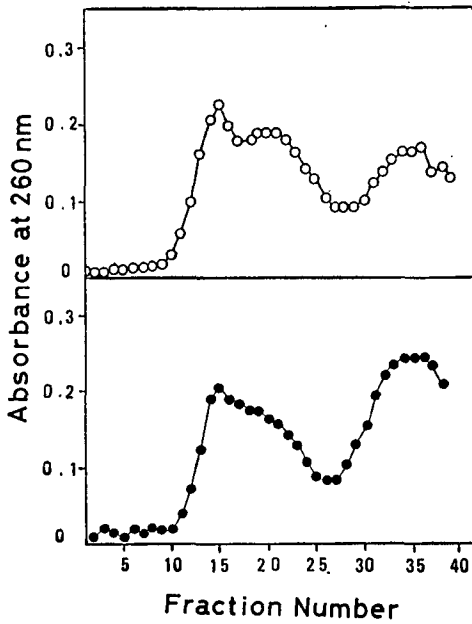

Figure 10. Ultraviolet absorption patterns of gradient columns centrifuged after layering concentrated preparations from infected (closed circle) and healthy (open circle) plants. Columns were centrifuged at 120,000 *g* for 180 minutes. (Experiment 3)

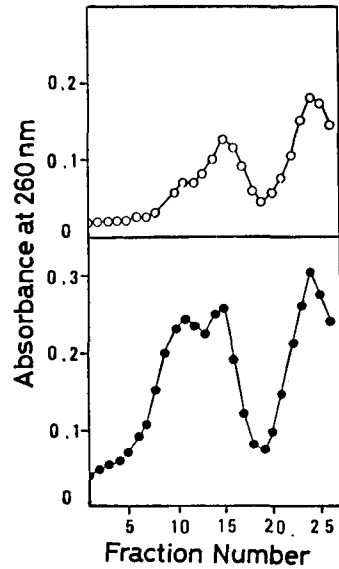

Figure 11. Ultraviolet absorption patterns of gradient columns centrifuged after layering concentrated preparations from infected (closed circle) and healthy (open circle) plants. Columns were centrifuged at 120,000 *g* for 120 minutes. (Experiment 4)

TABLE 15. Infectivity of each zone after sucrose density-gradient centrifugation (*Exp. 4*)

Fraction number	Number of aphids injected	Number of survivors ^a	Infectivity
1-6	50	36	0/5
7-12	50	41	2/5
13-18	50	44	2/5
19-26	50	30	0/5
Unfractionated	50	41	3/5

a 24 hours after injection

The resulting UV-absorbance patterns are shown in Fig. 11. Fractions collected were divided into four groups, numbers 1 to 6; 7 to 12; 13 to 18; and 19-26, and were assayed by aphid injection. As shown in Table 15, regions of two peaks (i. e., fraction 7-12; 13-18) were associated with infectivity, suggesting that the virus was distributed widely in the column due to aggregation.

2. Analysis by bioassay

a) Experimental procedure

Leaves and petioles of diseased *P. floridana* plants, harvested 10-16 days after inoculation and kept at -35°C , were ground in a mortar in a cold room (-35°C), gradually thawed at 4°C , and then homogenized in 0.1 *M* phosphate buffer (pH 7.4) containing 0.01 *M* DIECA. A chloroform and *n*-butanol mixture (1:1) was added to the expressed sap to make a final concentration of 25% and then stirred vigorously for 15 minutes. The emulsion was broken by low-speed centrifugation at 1,000 *g*. The aqueous phase was decanted and centrifuged at 20,000 rpm (33,000 *g*) for 15 minutes in the RP 30 rotor of a Hitachi 40-P ultracentrifuge. The supernatant was centrifuged again at 30,000 rpm (75,000 *g*) for 180 minutes. Resultant pellets were resuspended in 2 ml of 0.01 *M* phosphate buffer (pH 7.4) in a Teflon-glass homogenizer, and then centrifuged at 20,000 rpm (26,000 *g*) for 15 minutes. The preparations were further purified by means of sucrose density-gradient centrifugation. The density-gradient columns were prepared by layering 0.9 ml each of 10, 20, 30, 40, and 50% sucrose dissolved in 0.01 *M* phosphate buffer (pH 7.4) and kept for 24 hours in a cold room. One-half milliliter of the concentrated preparation was floated on the column. Tubes were centrifuged in the RPS 40 swinging-bucket rotor of a Hitachi ultracentrifuge at 35,000 rpm (100,000 *g*) for 120 minutes. Each zone was removed by puncturing the gradient tubes with hypodermic syringe, diluted to 5 ml with 0.01 *M* phosphate buffer (pH 7.4), and then centrifuged again at 100,000 *g* for 120 minutes. The pellets were resuspended in 0.01 *M* phosphate buffer (0.1 ml per 100 *g* for tissues), and assayed immediately for infectivity. All experimental procedures were performed at 4°C within a day. Injected aphids were reared on immune plants (tulip bud) for 24 hours at room temperature, and then transferred to test plants (6 aphids per plant).

b) Experimental results

After centrifugation, three light-scattering zones, 24-27 mm, 30-32 mm and 34-36 mm from the bottom of the gradient tubes were distinguished. Similar bands were also observed in a gradient tube with a preparation

from healthy *P. floridana* plants. Six experiments were done to detect the infectious zones in a sucrose density-gradient column. As shown in Table 16, the visible zones (fraction A, B, and C) were not associated with infectivity. High infectivities were recovered in fraction E and F, in which no visible bands were observed. Fraction G immediately below E-F had some infectivity. Some infectious material, probably aggregated virus particles, sedimented to the bottom of gradient tubes after centrifugation (Table 16, fraction I). The absence of visible bands in the infectious zones suggests that the concentration of the virus extracted from the infected plants was rather low.

TABLE 16. Infectivity of each fraction after sucrose density-gradient centrifugation

Experiment	Fraction ^a	Distance from tube bottom (mm)	Infectivity
1	F	15-18	2/5
	G	11-15	0/5
	H	6-11	0/5
2	F	15-18	4/5
	G	11-15	2/5
	H	6-11	0/5
3	D	21-24	0/5
	E	18-21	4/5
	F	15-18	3/5
4	D	21-24	0/5
	E	18-21	5/5
	F	15-18	3/5
5	B	30-32	0/5
	C	24-27	0/5
	E F	15-21	5/5
	I	0	2/5
6	A	34-36	0/5
	C	24-27	0/5
	E F	15-21	5/5
	I	0	3/5

a A-C: visible bands; D-H: without bands; I: pellet

3. Virus-like particles in the infectious zone

a) Observation of shadowed specimens

The glycerin washing method (ROCHOW and BRAKKE, 1964) was employed to prepare the electron microscopic specimen from the infectious zone (fraction E and F) described above. A part of the infectious zone with sucrose was dropped on the carbon coated formvar grids and kept for 3 hours in a cold room. Then the grids were floated on 20% glycerin solution for 20 minutes at room temperature to remove sucrose. After sucking off excess fluid with a piece of filter paper, the specimens were shadowed with tungsten oxide and observed with a JEM-5 Y electron microscope. The electron micrographs showed that the infectious zone contained small spherical virus-like particles (Plate I-A).

b) Observation of negatively-stained specimens

The infectious zone, 15–21 mm from the bottom, was removed, diluted to 5 ml, and centrifuged at 100,000*g* for 120 minutes in a RPS 40 swinging-bucket rotor. The sediment was fixed with 0.1 ml of 1% neutral formaldehyde and then centrifuged again briefly at 8,000 rpm (5,200*g*) for 20 minutes. The supernatant was mixed with an equal volume of 2% PTA (pH 7.0) and mounted on a grid. As shown in Plate I-B and C, spherical or polyhedral particles with uniform size and shape, approximately 24–25 nm in diameter were observed intermingled with considerable amount of amorphous precipitate.

No virus-like particles were found in 15–21 mm fractions from extracts of healthy *P. floridana* plants or from healthy aphids that were reared on tulip buds.

C. Discussion and brief conclusions

We have several techniques to separate viruses from normal cell constituents at present. I employed column chromatography with DEAE-cellulose and sucrose density-gradient centrifugation in this experiment. Many animal viruses have been purified by column chromatography with DEAE-cellulose, e. g., adenovirus (KLEMPERER., *et al.*, 1959, HARUNA., *et al.*, 1961), foot and mouth disease virus (BROWN and CARTWRIGHT, 1959), and Newcastle disease virus (Wilson, 1962). TOYODA., *et al.*, (1965) have applied this method to the purification of rice dwarf virus. I applied the procedure for RDV purification to separation of PLRV from cell constituents.

In this experiment, an extra component was not detected in the chromatogram of a concentrated preparation from the infected plants. Although the effluent eluted with 0.5–0.6 *M* NaCl was associated with some infectivity,

it was obvious that the effluent contained not only the virus but cell constituents, since the chromatogram of a preparation from healthy plants had similar absorbance. It was not known whether the virus had same electrostatic properties as cell constituents or was adsorbed by cell constituents. This technique seems to be inadequate for PLRV purification, probably due to a low concentration of the virus.

Sucrose density-gradient centrifugation (BRÄKKE, 1960) has been widely adapted to research on plant and animal viruses and bacteriophages. After centrifuging an unfractionated PLRV preparation layered onto a sucrose density-gradient column, an extra component was not detected spectrophotometrically in the "infected" preparation (MURAYAMA, KOJIMA and SUGAWARA, 1967). This result suggests that an unfractionated preparation obtained by clarification with a chloroform and *n*-butanol mixture followed by differential centrifugation, contained large amounts of normal cell constituents with not enough virus to detect spectrophotometrically. However, it was confirmed that a zone 15–21 mm from the tube bottom was associated with infectivity and that this infectious zone contained uniform spherical particles (24–25 nm in diameter). Furthermore, three visible bands not associated with infectivity did not contain uniform particles. These facts indicated that sucrose density-gradient centrifugation had separated the virus from normal cell constituents (KOJIMA *et al.*, 1968).

VII. Purification

The purification of PLRV from infected plants by sucrose density-gradient centrifugation was attempted, based on the experimental results in the preceding chapter. In this chapter, the purification procedure, morphological aspects and biological purity of PLRV are described.

A. Establishment of purification procedure

1. An attempt to isolate the virus from a large amount of plant material

An attempt was made to isolate the virus from frozen plant tissues (1,000 g). Each 200 g of frozen tissue was macerated in 400 ml of 0.1 M phosphate buffer, pH 7.4, containing 0.01 M DIECA, with a fruit juice extractor. Crude saps were emulsified with a chloroform and *n*-butanol mixture for 3 minutes. The emulsion was broken by centrifuging at 1,000 *g* for 10 minutes. The resultant brown aqueous phase was concentrated by differential centrifugation (33,000 *g* or 10 min; 75,000 *g* for 180 min.). The pellets were resuspended in small volumes of 0.01 M phosphate buffer, PH 7.4, with a Teflon-glass homogenizer.

Sucrose density-gradient columns, on which concentrated, unfractionated preparations were floated, were centrifuged at 100,000 *g* for 120 minutes in a RPS-40 swinging-bucket rotor. After centrifugation, the infectious zone (selected as in the preceding chapter) was removed by puncturing the gradient tubes with a hypodermic syringe, transferred a sealed small test tube and kept at -3°C . The procedures described above were performed at 4°C within a day. The procedures were repeated five on 5 days with 200 g of tissue each day. The infectious zones were combined, dialyzed overnight against 0.01 *M* phosphate buffer, pH 7.4 in a collodion-bag, and concentrated by differential centrifugation (26,000 *g* for 15 min ; 100,000 *g* for 120 min.). One-half milliliter of the concentrated preparation was placed on a sucrose column. After the tube was again centrifuged at 100,000 *g* for 120 minutes, a faint light scattering zone 15–21 mm from the tube bottom was removed, diluted to 5 ml and centrifuged at 100,000 *g* for 120 minutes in the same swinging-bucket rotor. The resultant pellet was resuspended in 0.1 ml ($\times 10,000$ concentrated) of 0.01 *M* phosphate buffer, pH 7.4, and assayed for infectivity. All 5 test plants infested with the injected phids (6 aphids per plant) became infected. Furthermore, the preparation contained many uniform spherical particles, although a considerable amount of amorphous material was also found (Plate I-D). In this way, it was possible to prepare the infectious virus preparation from 1,000 g plant materials during 5 days.

2. Effect of fluorocarbon on the infectivity

It was confirmed that the virus preparation treated with fluorocarbon, Daifron S-3 (PHILIPSON, 1967), during differential centrifugation was still highly infectious. A partially purified preparation from 200 g plant tissue was emulsified with 1/4 volume of Daifron S-3 for 3 minutes, and the emulsion was broken by centrifugation for 10 minutes at 1,000 *g*. The aqueous phase was given a subsequent differential centrifugation followed by sucrose density-gradient centrifugation. The 15–21 mm fraction was immediately assayed for infectivity by same procedure as described above. All six plants infested with the injected aphids developed typical symptoms on the leaves.

3. Final purification procedure

The final purification procedure, based on the results described above was as follows :

Step 1. Frozen tissues of diseased *P. floridana* plants (1,000 g) were ground in a fruit juice extractor with 2 ml of 0.1 *M* phosphate buffer (pH 7.4) containing 0.01 *M* DIECA for each gram of tissue.

Step 2. To one volume of the extract was added 0.25 volume of a mixture of chloroform and *n*-butanol (1 : 1) and the mixture was emulsified in a Waring Blendor for 3 minutes.

Step 3. The emulsion was broken by low-speed centrifugation at 1,000 *g* for 10 minutes.

Step 4. The aqueous phase was again centrifuged at 33,000 *g* for 15 minutes in the RP-30 rotor of the Hitachi ultracentrifuge.

Step 5. The clarified supernatant fluid was subsequently centrifuged at 75,000 *g* for 180 minutes.

Step 6. The resultant pellet was resuspended in 0.01 *M* phosphate buffer (pH 7.4) in a Teflon-glass homogenizer, and emulsified again with 1/4 volume of Daifron S-3 for 3 minutes. Subsequently the emulsion was broken by centrifugation for 10 minutes at 1,000 *g*.

Step 7. The aqueous phase was subsequently concentrated by centrifugation for 120 minutes at 100,000 *g*.

Step 8. The resultant pellet was resuspended in 4 ml of 0.01 *M* phosphate buffer (pH 7.4), and centrifuged at 26,000 *g* for 10 minutes.

Step 9. The supernatant was layered onto sucrose columns, made by layering 0.9 ml each of solutions containing 100, 200, 300, 400, and 500 mg sucrose per milliliter in 0.01 *M* phosphate buffer (pH 7.4), and then centrifuged in a swinging-bucket rotor (RPS-40) at 100,000 *g* for 120 minutes.

Step 10. The zone (faintly turbid) 15–21 mm from tube bottom was removed, dialyzed overnight against 0.01 *M* phosphate buffer, and pelleted by high-speed centrifugation at 100,000 *g* for 120 minutes in a RPS-40 swinging-bucket rotor.

Step 11. The resuspended preparation was layered onto the second density-gradient column and centrifuged at 100,000 *g* for 120 minutes.

Step 12. The virus zone was removed from the tube with a hypodermic syringe, diluted to 5 ml, and centrifuged again at 100,000 *g* for 120 minutes.

Step 13. The resultant pellet was dissolved in 0.1 ml of 0.01 *M* phosphate buffer (pH 7.4).

The procedures (*Step 1–6*) were performed during 3 days, and subsequent procedures (*Step 7–13*) were done during 2 days in a cold room. After the second density-gradient centrifugation (*Step 11*), two faint but visible bands, 15–17 mm and 19–21 mm from the bottom, were observed. Both visible zones were separately pelleted (*Step 12–13*), assayed immediately for infectivity, and observed with an electron microscope.

Aphids injected with each fraction transmitted the virus to all plants (6 for each sample) on which they fed. Furthermore, the bottom fraction

was still infectious after 7 days of storage in a cold room (4°C) i. e., 2 out of 6 assay plants infected, but the top fraction was not infectious after storage for 7 days. The bottom fraction (15–17 mm) consisted of the characteristic uniform spherical or polyhedral virus particles, while the top fraction (19–21 mm) contained a few spherical virus particles intermingled with a considerable number of amorphous particles.

Based on these results, it was concluded that the bottom fraction was the PLRV fraction.

B. Morphology of purified PLRV

Negatively stained preparations were made by placing a small drop of virus suspension on a carbon-coated formvar grid and adding a droplet of a 2% PTA in 0.05% bovine serum albumin. The excess fluid was sucked up with a small piece of filter paper. The specimens were examined with a JEM-5 Y electron microscope.

The top and bottom fractions were diluted and sedimented at 100,000g for 120 minutes. The resultant pellets were resuspended in 0.1 ml of 0.01 M phosphate buffer (pH 7.4) and then negatively stained with 2% PTA at pH 7.0. Numerous uniform spherical particles approximately 29 nm in diameter (side by side) were detected in the bottom fraction (Table 17). Some of them appeared hexagonal. It appears possible that there are some fine outer projections on the surface of the particles (Plate II-A, B). When the final virus suspension was taken up in 0.01 M phosphate buffer at pH 6.0 and negatively stained with 2% PTA adjusted to pH 5.5, most virions presented hexagonal profiles approximately 25 nm in diameter (Table 17, Plate II-D). Lastly, the final pellet was suspended in 0.01 M phosphate buffer (pH 6.0), fixed with an equal volume of 1% glutaraldehyde, and stained with 2% PTA (pH 5.5). As shown in Plate II-E, the virions presented hexagonal profiles with a diameter of 25 nm (Table 17).

TABLE 17. Size of PLRV particle

Sample	Medium for suspension	Fixative	Stain	Size measured (nm)
isolated preparation ^a		neutral formaldehyde	2% PTA, pH 7.0	24-25
	0.01 MPB ^b , pH 7.4		2% PTA, pH 7.0	29-30
purified preparation	0.01 MPB, pH 6.0		2% PTA, pH 5.5	25
	0.01 MPB, pH 6.0	glutaraldehyde	2% PTA, pH 5.5	25
ultrathin section ^c				23

a see VI Chapter b phosphate buffer c see next Chapter

Plate II-C shows an electron micrograph obtained from the top fraction. A few virions of PLRV were found intermingled with a considerable number of amorphous particles, which could be degraded virus particles.

The size of virions in various treatments is shown in Table 17. When the non-fixed suspensions were kept neutral, the virions had a tendency to swell slightly. On the other hand, the virions kept in slightly acid solution, or fixed, presented rigid profiles approximately 25 nm in diameter.

C. Biological purity

Since the presence of virus-like particles, carried by aphids with the moderate PLRV isolate, was demonstrated by PETERS (1965, 1967 a, b), the following experiments were carried out to see whether the diseased *P. floridana* plants or aphids were contaminated with any other viruses or virus-like particles.

1. Check of "virus-like particles" from aphids

About 500 mg of aphids reared on healthy Chinese-cabbage as a stock, were anesthetized with carbon dioxide, and homogenized in 10 ml of 0.1 M phosphate buffer (pH 7.4) in a Teflon-glass homogenizer. After clarification by chloroform and *n*-butanol, the aqueous phase was centrifuged at 100,000 *g* for 120 minutes in a RPS-40 swinging-bucket rotor. The resultant pellet was resuspended in 1 ml of 0.01 M phosphate buffer, and layered onto a sucrose column. After centrifugation at 100,000 *g* for 120 minutes, the 15-21 mm zone was removed, diluted to 5 ml and again pelleted at 100,000 *g* for 120 minutes. The pellet was resuspended in 0.1 ml of 0.01 M phosphate buffer, and negatively stained with 2% PTA (pH 7.0). As shown in Plate III-A, there were no particles in the 15-21 mm fraction of the purified preparations.

2. Check of "virus-like particles" from plants

Aphids fed on infected *Datura stramonium* plants for 3 days, were transferred to Chinese-cabbage plants which are immune to PLRV. After 2 weeks, a number of nymphs which appeared on the Chinese-cabbage plants were transferred to young *P. floridana* plants. Two weeks after infestation the plants were harvested and subjected to the same purification procedure used for PLRV from plants. The final pellet from 100 g of plant tissue, was resuspended in 0.1 ml of 0.01 M phosphate buffer (pH 6.0), and then negatively stained with 2% PTA. No virus-like particles were found in the final purified preparations. From this fact, it was obvious that the isolate of PLRV used here was not contaminated with other viruses able to propagate in Chinese-cabbage plants and to infect to *P. floridana* plants.

D. Effects of magnesium ion

The purified PLRV particles seem to be labile structurally. It is probable that the time required for purification was too long, and that the medium used for suspending the virus was not optimum. It has been known that magnesium or polyamines may stabilize spherical viruses (HIEBERT and BANCROFT, 1969). Effects of Mg^{2+} on the virus particles were examined as follows.

1. Biological examination

Infected *P. floridana* plants (150 g) were macerated in 0.01 M Tris-HCl-buffer (pH 8.0) containing 0.1 M $MgCl_2$, and the extract clarified by a chloroform and *n*-butanol. The aqueous phase was subjected to the purification procedure. The high speed pellet was suspended in 0.01 M Tris-HCl-buffer (pH 7.4) containing 0.1 M glycine and 0.01 M $MgCl_2$. After the first sucrose density-gradient centrifugation, a visible band, 8–18 mm from the bottom, was removed, diluted to 5 ml and then centrifuged again at 100,000 g for 120 minutes. The resultant pellet was resuspended in 0.1 ml of Tris-HCl-buffer (pH 6.0) containing 0.1 M glycine and 0.01 M $MgCl_2$, and assayed immediately for infectivity. A broad light-scattering zone, which included the so-called virus zone (A, 3 in this chapter), was not infectious (Fig. 12).

2. Electron microscopic observation

The diseased tissues (300 g) were ground in 2 ml of 0.1 M phosphate buffer (pH 7.4) containing 0.01 M DIECA added for each gram of tissue. The juices were clarified and concentrated by 2 cycles of differential centrifugation. A pellet was resuspended in 0.01 M phosphate buffer (pH 7.0) containing 0.01 M $MgCl_2$. As shown in Fig. 13, a light-scattering zone,

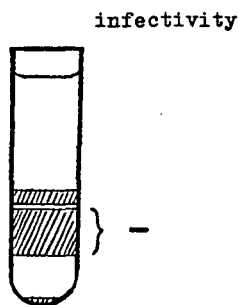

Figure 12. Schematic sketch of a sucrose gradient column with 0.01 M $MgCl_2$ centrifuged at 100,000 g for 120 minutes and infectivity of "virus zone".

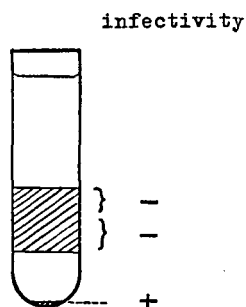

Figure 13. Schematic sketch of a sucrose gradient column with 0.00 M $MgCl_2$ centrifuged at 100,000 g for 120 minutes and infectivities of three zones.

11–23 mm from the bottom was observed. This zone was divided two fractions, the 11–17 mm fraction and the 17–23 mm fraction. Each fraction was diluted to 5 ml with the resuspending medium and then centrifuged at 100,000 *g* for 120 minutes. The resultant pellets and the pellet obtained by first sucrose density-gradient centrifugation were dissolved in 0.1 ml of 0.01 *M* phosphate buffer (pH 7.0) containing 0.01 *M* MgCl₂, and then assayed for infectivity. Neither fraction (visible zone) was infectious, but the pellet from the density-gradient centrifugation was (Fig. 13). Each sample was negatively stained with 2% PTA (pH 5.5) and observed in the electron microscope. A large number of small amorphous particles were found in a visible zone (Plate III-B). These particles seemed to be aggregated ribosomes from plant cells. The PLRV particles were probably aggregated by the Mg²⁺, and sedimented to the pellet during sucrose density-gradient centrifugation.

E. Purification of the virus from root tissues

Leaves and petioles of infected *P. floridana* plants were the source of virus previously purified. An attempt was made to purify the virus from root tissues of infected plants.

Frozen root tissues (100 g) of diseased *P. floridana* plants were ground in a meat chopper and then homogenized with 0.1 *M* phosphate buffer (pH 7.4) containing 0.01 *M* DIECA, 2 ml for each gram of tissue. Concentrated preparations of the virus were made by chloroform-butanol clarification and 2 cycles of differential centrifugation as described above. After sucrose density-gradient centrifugation, the virus zone was removed, and again pelleted. The final pellet was resuspended in 0.1 ml of 0.01 *M* phosphate buffer (pH 7.4). The preparation was injected into aphids and negatively stained with 2% PTA (pH 5.5).

All six test plants infested by aphids, which had been injected with the final preparation either undiluted or diluted 40-fold, developed typical symptoms. On the other hand, the preparation contained many not-uniform contaminants along with a few virus particles (Plate III-C). After repeated experiments, it was concluded that while infectious virus particles could be recovered from the root tissues, these root tissues were not a good virus source for purification.

F. Attempts to simplify the concentrating procedure of clarified sap

1. Concentration by evaporation

Extracts from 200 g fresh leaves of diseased *P. floridana* plants were clarified by the chloroform and butanol method. The resultant aqueous

phase was evaporated under reduced pressure for 20 minutes in water bath (35°C) in a rotary evaporator. The clarified sap was reduced to one-fourth volume in 20 minutes. Concentrated preparations were further purified by differential centrifugation followed by sucrose density-gradient centrifugation. When the final pellet was assayed for infectivity, it was not infectious. Furthermore, electron micrographs showed that the preparation consisted of amorphous, disrupted particles.

2. Centrifugation in sucrose cushion

As loss or disruption of the virus during purification seemed to be due to repeated centrifugation, an attempt was made to concentrate the virus by centrifugation onto a sucrose cushion. To the juice obtained from 300 g of fresh *P. floridana* plants, was added an equal volume of saturated ammonium sulfate (adjusted to pH 7.0). The mixtures were stirred for 5 minutes and then kept in centrifuge tubes for 60 minutes. The flocculated material was collected by centrifugation at 1,000 g for 20 minutes. The precipitates were dissolved in 60 ml of 0.01 M phosphate buffer (pH 7.4), and then clarified by a chloroform and *n*-butanol mixture. Each 20 ml of aqueous phase was directly layered onto 3 sucrose-cushions, which were made by layering each 3 ml of 200 and 700 mg sucrose per milliliter, respectively, in centrifuge tubes (1 × 3 inch), and kept for 24 hours in a cold room (Fig. 14-1). Subsequently, the columns were centrifuged at 60,000 g for 120 minutes in a RPS-25 swinging bucket rotor (Fig. 14-2). After centrifugation, the cushion zone was turbid (Fig. 14-3). The cushion zone was divided into two fractions and each was dialyzed overnight against 0.01 M phosphate buffer (pH 7.4) in a cold room at 4°C, and subsequently pelleted by centrifugation at 100,000 g for 120 minutes in a RPS-40 rotor. The resulting pellets were resuspended in the same buffer, and subjected to sucrose density-gradient centrifugation as described previously. Each virus zone was removed and examined in the electron microscope. The electron micrograph showed that both fractions of the sucrose cushion contained virus particles (Plate III-D,

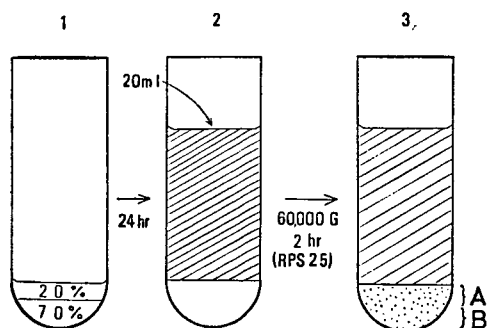

1. sucrose cushion; 2. clarified preparation layered onto the cushion 24 hours after layering sucrose; 3. centrifugation at 60,000 g for 120 minutes.

Figure 14. Centrifugation onto a sucrose cushion.

E). The same results were obtained when the experiment was repeated twice. This fact indicated that the virus particles were not effectively collected in the upper zone within a sucrose cushion under the condition used here.

G. Discussion and brief conclusions

PLRV was purified by the procedure shown in this chapter, which included clarification with organic solvent (a chloroform and *n*-butanol mixture, and Daiflon S-3), 2 cycles of differential centrifugation, and subsequently 2 cycles of sucrose density-gradient centrifugation. Two visible zones were obtained after the 2nd sucrose density-gradient centrifugation, and both zones were associated with infectivity. The bottom fraction contained many uniform spherical particles, but the top fraction consisted of a few spherical particles intermingled with a considerable number of amorphous particles (KOJIMA *et al.*, 1969). Similar results were encountered in the purification of pea enation mosaic virus (GIBBS *et al.*, 1966). The "upper light-scattering layer" in the centrifuged sucrose density-gradient column was associated with some infectivity and contained a few intact virus particles. Although the unfixed particles had spherical or polyhedral profiles, the fixed virus particles (either in formaldehyde or glutaraldehyde) appeared hexagonal in outline suggesting that the shell is icosahedral in shape like other isometric viruses which have been studied.

The fixed particles appeared smaller than the unfixed particles, indicating that the latter were probably more flattened (HULL *et al.*, 1969). As the size of the fixed particles corresponded with that of the particles suspended and stained under acidic condition, PLRV probably has hexagonal particles 25 nm in diameter (side to side). Peters (1967 a, b) reported that the size of PLRV particles purified from aphid vectors was 23 nm in diameter. The measurement was done on preparations suspended in phosphate buffer (pH 7.2) and stained with 2% PTA (pH 5.5). ARAI *et al.*, (1969) partly purified PLRV from three kinds of the diseased plants, *P. floridana*, *D. stramonium* and potato plants, and each of the final preparations suspended in 0.005 M phosphate buffer (pH 8.0) contained spherical particles approximately 25 nm in diameter. It is known that the hydrodynamic behaviour of some small isometric viruses is pH dependent, and that the particles swell near neutrality and in doing so become susceptible to attack by RNase (BANCROFT *et al.*, 1967).

The electron micrographs (Plate II-A, B) showed that the particles suspended in phosphate buffer (pH 7.4) and subsequently stained with 2% PTA

(pH 7.0), had some surface structure, and some were disrupted. These photographs were quite similar to that of cucumber mosaic virus when suspended in distilled water and stained with 1% PTA (pH 6.0) (MURANT, 1965).

The top fraction contained a considerable number of amorphous particles which had same surface structure as the virus and some disrupted virus particles (Plate II-C). In the case of pea enation mosaic virus, the "upper light-scattering layer" contained some disrupted virus particles (GIBBS *et al.*, 1966), and the photograph of them was similar to that shown in Plate II-C.

There was no evidence of so-called "empty" virus shells like those found in negatively stained preparations of many other isometric viruses (BAWDEN, 1964). Similarly, no empty shells were found in the preparations of pea enation mosaic virus (GIBBS *et al.*, 1966; BOZARTH and SHOW, 1966). One of reasons that no "empty" shells are found in these viruses, is thought to be because there are strong attractive forces between the RNA and protein. The proteins of some; e. g. pea enation mosaic, have a high proportion of basic amino acids and therefore probably have a strong electrostatic attraction for RNA. The virions of viruses that readily form empty shells are held together predominantly by protein-protein interactions, e. g., turnip yellow mosaic virus (KAPER, 1971). MURANT (1965) pointed out that many CMV particles were disrupted by phosphotungstate, and preparations examined after 1.5 hours in the stain showed no intact virus particles. His attempts to improve the preservation of the particles by fixation for 30-60 minutes in 1% formaldehyde were unsuccessful, and good photographs were obtained only when preparations were dried onto the microscope grid as soon as possible after mixing the virus suspension and PTA. FRANCKI *et al.*, (1966) also reported that CMV (Q strain) was unstable and was slowly disrupted in 2% PTA. Their micrographs of CMV were obtained from preparations in which virus solutions were applied to grids and were fixed in OsO₄ vapour for 10 seconds and then stained with 3% unbuffered uranyl acetate. Furthermore, they examined the virions directly in the analytical ultracentrifuge and found evidence of disintegration of CMV particles by PTA. Alfalfa mosaic virus, even though it is a virus with multiple components, also does not withstand negative staining in neutral PTA unless previously fixed in 1% formaldehyde (GIBBS *et al.*, 1963). According to results reported by HULL *et al.*, (1969), the analytical ultracentrifuge showed that AMV broke down in the presence of 1% PTA in a manner similar to that shown for CMV (FRANCKI *et al.*, 1966). However, they succeeded in staining unfixed AMV particles with saturated uranyl formate.

The viruses mentioned above also have other properties in common, i. e., they are sensitive to magnesium ions. The bottom, middle, and top components of AMV were precipitated by the addition of MgCl_2 to give 0.005 M Mg^{2+} (HULL and JOHNSON, 1968). As one of reasons, they thought that the precipitation of the virus arises from the binding of Mg^{2+} to RNA phosphate (or possibly between phosphate and carboxyl groups) with the consequent reduction in the charge of the particles, and that the phosphate groups must be near the surface to participate in interparticle charge effects. CMV began to precipitate at 0.001 M of MgCl_2 (TAKANAMI and TOMARU, 1969). They improved the Scott's purification procedure (SCOTT, 1963) by addition of 0.005 M EDTA to sucrose density-gradient columns. In my experiment, PLRV particles were precipitated in sucrose density-gradient columns in the presence of Mg^{2+} .

The small isometric viruses may be divided into two groups according to the action of Mg^{2+} . The viruses of one group are precipitated by Mg^{2+} and are stabilized by EDTA. The viruses of another group are stabilized by Mg^{2+} and inactivated by EDTA. Southern bean mosaic virus is representative of the latter group (WELLS and SYSLER, 1969). Thus the small isometric viruses with a relatively high RNA content (KAPER, 1968) respond differently to the action of Mg^{2+} , from the point of view of stability. Further detailed studies concerning the stability and structure of PLRV are indispensable.

As the PLRV-isolate used in this study was free of any detectable contaminating virus, it may be concluded that the particles found in final preparation were the causal agent of the leaf-roll disease of potato.

However, the purification procedure was fairly laborious and resulted in considerable loss of virus.

Thus I attempted to collect the virus particles from the top of the 70% sucrose pad without differential centrifugation (ERIKSON, 1969), but did not succeed.

In future, a large scale purification will be required for biochemical or biophysical studies of this virus, and thus further investigations to simplify the procedure are necessary.

VIII. Intracellular localization of the virus within plant hosts

A. Experimental procedure

1. Fixation and embedding

Small pieces of leaves and petioles from infected and non-infected plants, were placed in 75% ethanol, and then washed in distilled water.

Samples were then placed in a droplet of cold buffered 5% glutaraldehyde (pH 7.0) on a glass slide, and cut into small pieces (2×6 mm). After 120 minutes fixation in 5% glutaraldehyde buffered in pH 7.0 phosphate buffer, specimens were washed in 0.1 M phosphate buffer and were post-fixed in 2% osmium tetroxide for 90 minutes. After rinsing with 75% ethanol for 120 minutes, and transferred again into 75% ethanol. Further dehydration in graded ethanol was followed by staining with saturated lead acetate in 100% ethanol for 60 minutes, after which the materials were dehydrated again in 100% ethanol, and then embedded in Epon epoxy resin. The procedure throughout fixation and dehydration was done in a cold room at 4°C.

2. Ultrathin section and staining

Ultrathin sections were cut with a Porter-Blum Mt-1 ultramicrotome equipped with glass knives, and were stained with 3% uranyl acetate for 30 minutes. After washing with distilled water, the sections were stained again with Millonig Pb stain for 10 minutes, and then viewed and photographed with a JEM-5 Y electron microscope (80 kv).

B. Results

1. Ultrathin sections of *P. floridana* plants

Electron microscope examinations of ultrathin sections of *P. floridana* plants infected with PLRV indicated that the virus was localized in phloem tissue even though in low frequency, but was not found in other tissues, such as epidermis, mesophyll cells and xylem vessels.

In ultrathin sections of PLRV-infected plants, masses of small electron-dense particles of uniform size and shape, approximately 23 nm in diameter, were found. These particles usually appeared in degenerated phloem cells of petioles and veins of diseased leaves. Frequently, the cells containing virus particles had large areas filled with a network structure. Virus particles were scattered singly or in masses in the network structure of degenerate cells (Plate IV-A, C). Also virus particles were scattered singly throughout the lumen of the cell and interspersed with remnants of cell organelles (Plate IV-B). Accumulation of the virus in a remarkable crystal in the vacuole of phloem cells is shown in Plate V-A. Serial sections of these crystalline arrays, partly shown in Plate V-A and VI, revealed that they definitely consisted of spherical particles. Such crystalline arrays of the virus particles were rarely seen in cells of old diseased leaves, i. e., more than 50 days after infection.

Occasionally there were necrotic cells adjacent to cells containing PLRV.

One of them had densely staining material throughout the cell with a triangle shape (Plate VIII-C). In another necrotic cell, a densely staining material was deposited in the center of the cell (Plate VIII-B). In these necrotic cells, no virus particles could be detected. However, the necrotic cells with a network of densely staining fibers contained the virus particles (Plate VIII-A).

2. Ultrathin sections of *D. stramonium* plants

In *D. stramonium* plants infected with PLRV, virus particles also occurred within cells of phloem tissues either scattered or in accumulations, but rarely in crystalline arrays as in *P. floridana* plants. Clear virus profiles are seen in Plate V-B. Virus particles of uniform size and shape appeared in dense structures in the cell, or were free beside the cell wall. Accumulations of the virus, even though not in a crystalline array, were found in the central vacuole of phloem cells (Plate VII-A, B).

In *D. stramonium* plants necrotic cells were also observed adjacent to cells containing PLRV (Plate VII-A).

The virus particles appeared round or hexagonal in outline and uniform in shape and diameter when viewed in transverse sections of the phloem cells of both host plants. The largest clearly resolved particles in crystalline arrays were approximately 23 nm in diameter (see Table 17), which corresponded with that of the virions from purified preparations.

C. Discussion and brief conclusions

It is well known that staining with uranyl nitrate during dehydration is effective in strengthening contrast (MILNE, 1966; HILLS and PLASKITT, 1968). Furthermore, staining with uranyl nitrate and lead acetate, simultaneously, during dehydration (KUSHIDA and FUJITA, 1967), was more effective than a single stain for observing small isometric virus particles such as PLRV *in situ* in cells of infected plants. The virus particles differed from ribosomes in several aspects. In general, they stained more densely than the ribosomes; virus was always round or hexagonal with a discrete margin; ribosomes were frequently pleomorphic with an indistinct margin. There were some indications of crystallization of the virus particles (Plate V-A, VI); whereas ribosomes are not known to crystallize under normal experimental conditions. Also the virus particles differed from phloem protein (ESAU and CROUSHAW, 1967) which appear elongate when seen in longitudinal sections of phloem cells (see Plate VII-C).

Since the particles of uniform size and shape were encountered in the ultrathin sections of the diseased plant cells, and apparently corresponded

with those of the purified particles from plant tissues, it is likely that these particles are potato leaf-roll virus.

ARAI *et al.*, (1969) confirmed the virus localization within cells of *P. floridana*, *D. stramonium* and *Solanum tuberosum* plants. Their sections revealed uniform particles, spherical with a diameter of approximately 24 nm in the phloem tissue of all three hosts. They also pointed out that these particles were observed within the young xylem vessels.

From the results described above, PLRV appears to be confined to the phloem, where it causes a degeneration of the phloem cells. I have examined other tissues of PLRV-infected plants but found no particles of the type mentioned previously. However, one cannot exclude the possibility of overlooking or mistaking virus for ribosomes in the mesophyll and other cells except the phloem cells.

In PLRV-infected plants, phloem necrosis has been observed under the light microscope by many workers. But as shown in ultrathin section illustrated here, so-called phloem necrosis appears to be divided between the degenerate cells which contain the virus particles, and the necrotic cells which contain no particles.

The low concentration of PLRV in the sap of infected plants was also deduced from the fact that distribution of the virus was restricted to phloem tissues. For example, only one cell in an entire vascular bundle contained virus particles, as shown in Plate VII-A.

It is not known where the virions are multiplied and assembled in host plants cells. In ultrathin sections of cells infected with PLRV, I did not recognize a viroplasmic matrix as found viruses such as wound tumor, rice dwarf, and rice black-streak dwarf viruses (SHIKATA and MARAMOROSCH, 1965, SHIKATA, 1968, 1969).

IX. General discussion

In the past 20 years, many developments have been made in the field of insect transmitted plant viruses, especially leafhopper borne plant viruses. These advances depended on improved techniques of preparation of nucleoprotein and electron microscopy. Among them, potato yellow dwarf virus was isolated for the first time from plant hosts by differential centrifugation (BLACK *et al.*, 1948) and by sucrose density-gradient centrifugation (BRAKKE *et al.*, 1951). Wound tumor virus was successfully isolated from both plant and insect hosts, and was found to be a large spherical virion with a diameter of 70–85 nm (BRAKKE *et al.*, 1954). Rice dwarf virus was subsequently isolated from both plant and insect hosts and its morphology

determined to be similar to that of wound tumor virus (FUKUSHI *et al.*, 1960, 1962). In addition, the fine structures of these three viruses were determined under the electron microscope (BILS and HALL, 1962, BLACK *et al.*, 1965; FUKUSHI and SHIKATA, 1963; KIMURA and SHIKATA, 1968). To date, the size and shape of many viruses transmitted by leafhoppers or planthoppers, have been determined (i. e., maize mosaic virus (HEROLD *et al.*, 1960, 1967; wheat striate mosaic virus (LEE, 1967, 1968), northern cereal mosaic virus (SHIKATA and LU, 1967; LU *et al.*, 1968), maize rough dwarf virus (LOVISOLO *et al.*, 1967), rice tungro virus (GÁLVEZ, 1968), rice streak virus (KITANI and KISO, 1968), rice black-streak dwarf virus (KITAGAWA and SHIKATA, 1969), and rice transitory yellowing virus (SHIKATA and CHEN, 1969). Rice tungro virus was the only one of these which was transmitted non-persistently by a leafhopper (LING 1966). These viruses are variable in morphology. There are four types, viz., large spherical particles with outer projections (rice dwarf and wound tumor viruses) or without projections (maize rough dwarf and rice black-streak dwarf viruses), bacilliform or bullet-shaped particle (maize mosaic, wheat striate mosaic, northern cereal mosaic and rice transitory yellowing viruses) and small isometric particles (rice tungro and rice streak viruses).

Other meaningful findings were given by observation of the viruses within cells of both plant and insect hosts by ultrathin section. Localization of rice dwarf virus within both plant and leafhopper tissues was first described (FUKUSHI *et al.*, 1962; SHIKATA, 1966). Many viruses have been observed within both hosts as follows; wound tumor virus (SHIKATA *et al.*, 1964; SHIKATA and MARAMOROSCH, 1965), maize mosaic virus (HEROLD and MUNZ, 1965), potato yellow dwarf virus (MACLEOD *et al.*, 1966), wheat striate mosaic virus (LEE, 1964, 1967), northern cereal mosaic virus (SHIKATA and LU, 1967), maize rough dwarf virus (LOVISOLO and CONTI, 1966), rice black-streak dwarf virus (SHIKATA, 1968), and rice transitory yellowing virus (SHIKATA and CHEN, 1969). Finding of virus particles in several internal organs of insect vectors provided additional evidence for virus multiplication in the insect vector. Furthermore, several types of ultrastructural change of cells of both hosts infected with these viruses have been discussed in relation to the site of virus multiplication.

The viral RNA's of wound tumor and rice dwarf viruses have been extensively studied (BLACK and MARKHAM, 1963; GOMATOS and TAMM, 1963; MIURA *et al.*, 1966; SATO *et al.*, 1966), as has the serology (WHITCOMB and BLACK, 1961; WHITCOMB, 1964; NAGARAJ and BLACK, 1961; NAGARAJ *et al.*, 1961; KIMURA and SUZUKI, 1965), because of the high

TABLE 18. Some characters of aphid-borne persistent viruses

Virus	PLRV	BYDV	PEMV	CaMV	LNyV	SYVV
Vector	<i>Myzus persicae</i>	<i>Macrosiphum avenae</i>	<i>Achyrthosiphon pisum</i>	<i>Cavariella aegopodiae</i>	<i>Hyperomyzus lactucae</i>	<i>Hyperomyzus lactucae</i>
Pattern of transmission	propagative ^{a)}	circulative	circulative	circulative ^{a)}	propagative	propagative
Sap transmission	impossible	impossible	possible	possible	possible	possible
Particle shape size	isometric 23-25 nm	isometric 30 nm	isometric 22-24 nm	isometric 30 nm	bullet (baciriform) 66×227 nm	bullet (baciriform) 80×220 nm
Sedimentation constant	—	115-118 S	T 106 S ^{a)} B 122 S	—	943 S	—
Tolerance to chloroform	positive	positive	positive	—	negative	—
Envelope	negative	negative	negative	negative	positive	positive
Yield	—	25-50 µg/ℓ	0.3 mg/g	—	—	—
Nucleic acid	—	—	RNA	RNA ^{b)}	—	—
Distribution plant	phloem	phloem	epidermis, mesophyl ^{b)} , phloem, xylem	—	epidermis, mesophyl, xylem	mesophyl ^{a)}
insect	—	—	gut lumen, fat body	—	salivary gland, muscle, intestine, fat body	salivary gland ^{a)}
Remarks	a) circulative, probably		a) multicomponent b) nucleus infection	a) with red leaf virus b) based on RNase treatment		a) nucleus infection

* PLRV: potato leaf-roll virus; BYDV: barley yellow dwarf virus; PEMV: pea enation mosaic virus; CaMV: carrot mottle virus; LNyV: lettuce necrotic yellows virus; SYVV: sowthistle yellow vein virus

yield and high purity in which these viruses can be prepared.

Researches on aphid-borne persistent plant viruses became active during the past 10 years, based on advances in studies on leafhopper-borne plant viruses. The nature and properties of virions of 5 aphid-borne persistent viruses besides PLRV have been determined to some extent, i. e., barley yellow dwarf (ROCHOW and BRAKKE, 1964; JENSEN, 1969), carrot mottle (WATSON *et al.*, 1965), pea enation mosaic (IZADPANAH and SHEPHERD, 1966; SHIKATA *et al.*, 1966), lettuce necrotic yellows (CROWLEY *et al.*, 1965; HARRISON *et al.*, 1965) and sowthistle yellow vein viruses (RICHARDSON and SYLVESTER, 1968). About 40 viruses are known to be transmitted persistently by aphid vectors (KENNEDY *et al.*, 1962; GIBBS, 1969). Although the transmission pattern of these viruses is similar, it is difficult to compare and discuss them completely at the virions level at present. The particles of only a few aphid-borne persistent viruses have been described. These viruses for which particles have been observed are summarized in Table 18. PLRV and barley yellow dwarf viruses, which have been not transmitted mechanically, have isometric particles with 25–30 nm diameter and have a very small concentration in the sap of infected plants. Both viruses are classified as the leaf-roll virus group (GIBBS, 1969). According to GIBBS, this group contains some additional viruses based on their transmission pattern and symptomatology, even though their particles have been not yet determined. Pea enation mosaic virus, which is readily transmitted mechanically, has isometric particles 30 nm diameter. Carrot mottle virus is unusual in that it can be transmitted mechanically, but is only transmitted by aphid from plants also infected with carrot red leaf virus. Its particles are approximately spherical and about 50 nm in diameter. Lettuce necrotic yellows and sowthistle yellow vein viruses are readily transmitted mechanically, but are unstable in sap. Both have similar distinctive bacilliform or bullet particles.

All four viruses, except carrot mottle virus, were purified by sucrose density-gradient centrifugation. Lettuce necrotic yellows virus has also been purified by column chromatography on calcium phosphate gel (MCLEAN and FRANCKI, 1967). Barley yellow dwarf virus was the first of these viruses to be purified (ROCHOW and BRAKKE, 1964). In my investigation, column chromatography with DEAE-cellulose was first tested for the purification of PLRV, but the results were unfavourable, maybe because of the low concentration of the virus. Eventually, PLRV was also purified by sucrose density-gradient centrifugation. In the case of the leaf-roll virus group, bioassay for infectivity of each fraction of sucrose columns after

centrifugation appears to be a most important step because there are no more sensitive or accurate assay methods than bioassay, even though it is fairly laborious. Spectrophotometrical measurement of nucleo-proteins and observation under electron microscope are meaningless, when the virus concentrations are very low.

Small isometric viruses among the 6 viruses are tolerant to organic solvents, but both lettuce necrotic yellow and sowthistle yellow vein viruses are sensitive to one, suggesting that both viruses have an envelope which is essential to integrity of these virions. In fact, it was reported that particles of these viruses were bacilliform or bullet shape with an envelope (HARRISON and CROWLEY, 1965; RICHARDSON and SYLVESTER, 1968). They closely resemble particles of some leafhopper-borne plant viruses described above and animal viruses such as vesicular stomatitis virus (BROWN *et al.*, 1967).

Morphology of PLRV, barley yellow dwarf, and pea enation mosaic viruses appears to be quite similar to many small isometric viruses, the surface of which generally consist of 180 subunits, except cowpea mosaic virus (190 in all) (KAPER, 1968).

Barley yellow dwarf virus sediments as a single component (i. e., 115–118 S). Conversely, pea enation mosaic virus sediments as two components (106 S and 122 S), but whether only one of these is infectious is not certain. The sedimentation rates of the small isometric viruses lie between 83 S (broad bean mottle virus) to 132 S (tomato bushy stunt virus), mainly between 99 S to 119 S (KAPER, 1968). The sedimentation rate of PLRV would probably be within this range.

It is generally accepted that the small isometric viruses contain a relatively high content of nucleic acid from 15% (tomato bushy stunt virus) to 42% (tobacco ring spot virus). Among aphid-borne persistent viruses pea enation mosaic virus is the only one whose nucleic acid has been characterized (SHEPHERD *et al.*, 1968). Its particles contain 27% RNA with a molar base ratio (G : A : C : U) of G 26 : A 24 : C 24 : U 26. No viral nucleic acid has been reported for the leaf-roll virus group. BRANDENBURG (1962) reported that DNA extracted from PLRV-infected potato leaves was the causal agent of potato leaf-roll. However, this result was disputed by some workers (GOVIER, 1963; SARKAR, 1963; KÖNIG, 1964; KÖING and MUELLER, 1964).

Based on the present knowledge described above, it is presumed that PLRV has isometric particles 25 nm in diameter with some surface structures, contains more than 20% nucleic acid, and sediments as a single

component (about 120 S).

As described above, some of the aphid-borne persistent viruses show some characteristics common to certain small isometric viruses, but are distinguished from other isometric viruses in yield. Yield of viruses that are sap inoculative is from mg to g level from one liter of plant sap (KODAMA, 1968). Yield of barley yellow dwarf virus from plant materials was estimated to be 25–50 μg per one liter of sap based on the scanning pattern of the ISCO fractionator (ROCHOW and BRAKKE, 1964). In my investigation, a faint visible band was observed in only a few experiments in which more than 1 kg of plant tissue was used as virus source, suggesting that the yield of PLRV from plant tissues was quite similar to that of barley yellow dwarf virus. Its value corresponds to between one thousandth and one tenthousandth of many sap inoculative plant viruses. The low concentration has been a limiting factor in purification of the leaf-roll virus group. PETERS (1967 b) reported that homogenates of viruliferous aphids contained PLRV more than plant sap, based on the results of bioassay. However, the results of bioassay of crude preparations may not reflect the actual virus concentration.

The low concentration of PLRV within plant tissues is also suggested by the localization of the virus. In this investigation, it was found that PLRV was restricted to phloem tissues. In addition, PLRV was found in only a few cells of phloem tissue. Barley yellow dwarf virus was also reported to be localized in phloem tissue (JENSEN, 1969). The similarity in the localization and cytopathology in PLRV and barley yellow dwarf viruses is interesting. Conversely, the distribution of pea enation mosaic virus within plant tissues is distinctly different from that of the leaf-roll virus group. Pea enation mosaic virus was observed in epidermis, mesophyll and vascular bundle tissues (SHIKATA *et al.*, 1966). In addition, the virus was in nuclei at an early step of infection (SHIKATA and MARAMOROSCH, 1966). Lettuce necrotic yellows virus was also distributed throughout whole tissues (CHAMBER *et al.*, 1965; CHAMBER and FRANKI, 1966). Four aphid-borne persistent viruses mentioned above divide into two groups on the basis of virus localization in plant hosts. The leaf-roll virus group (PLRV and barley yellow dwarf virus) which have a low concentration of virus in the plant restricted to phloem tissues. Pea enation mosaic and lettuce necrotic yellow viruses, which can be transmitted by sap and have a relatively high concentration in the plant, are distributed in epidermis and other tissues. Based on this fact, virus localization in plant host appears to be responsible for virus yield and the possibility of sap inoculation.

In the case of the leaf-roll virus group, it should be called "tissue infection", although it is local infection in a way.

Viruses for which particles have been observed in sections of viruliferous aphids include pea enation mosaic, lettuce necrotic yellows, and sowthistle yellow vein viruses. Pea enation mosaic virus is the first to be observed in the aphid vector. The virus was scattered in gut lumen and fat body of pea aphid, *Acyrtosiphone pisum* (SHIKATA *et al.*, 1966). This discovery, however, is not complete proof for virus multiplication within insect vectors (SYLVESTER, 1969). Lettuce necrotic yellows and sowthistle yellow vein viruses were detected in several internal organs (O'LOUGHLIN and CHAMBER, 1967; RICHARDSON and SYLVESTER, 1968). The latent period of these viruses in aphid vectors had been determined to be about one week (STUBBS and GROGAN, 1963; DUFFUS, 1963), which is longer than that of other aphid-borne viruses. In addition, sowthistle yellow vein virus could be transmitted serially from insect to insect by manual inoculation and transovarially. These facts suggest that these viruses multiply in cells of different organs and tissues of insect vector (SYLVESTER and RICHARDSON, 1969; SYLVESTER, 1969). Conversely, PLRV ironically was not detected in internal organs of the green peach aphid, *M. persicae* (MOERICKE, 1961, 1963), although it was the first virus reported to multiply in the aphid vector (STEGWEE and PONSEN, 1958).

As summarized in Table 18, PLRV is quite similar to barley yellow dwarf virus from several viewpoints, suggesting that these viruses form a new and unique group among plant viruses. Beet western yellows (DUFFUS and GOLD, 1965; SUGIMOTO *et al.*, 1970) and soybean dwarf viruses (TAMADA *et al.*, 1969; TAMADA, 1972; KOJIMA and TAMADA, unpublished) are probably of the leaf-roll virus group.

Finally, the relationships between potato leaf-roll disease and PLRV as the causal entity is depicted. Many workers have confirmed that potato leaf-roll (virus) is transmitted by aphid vectors, but not mechanically by sap. Transmission of the virus from viruliferous adult to progeny has generally been thought to be negative. In Japan, however, it was reported that a few progeny from viruliferous adults transmitted the virus during the winter season only (MIYAMOTO and MIYAMOTO, 1966). The spread of the disease (virus) from plant to insect and from insect to plant was shown by infectivity tests, viz., aphids can be infected by injecting them with extracts from infected plants and from viruliferous aphids. In addition, the pathway was revealed at virus particle level. In this investigation, infectious virions were successfully purified from the infected plant hosts. Conversely, PE-

TERS (1967 a, b) succeeded in purifying the same virion from viruliferous aphids. Both results taken together reveal that virions pass from plant to insect hosts or from insects to plant hosts. Detection of virions within phloem tissues is a circumstantial evidence for the idea that aphids are capable of picking up of virus from phloem tissues with nutrient and injecting it to phloem tissues with saliva. However, I still have some problems deciding how and where PLRV multiplies or assembles in plant host, and whether the virus is indeed capable of multiplying in its vector. Furthermore, I wish to investigate the biochemical and physicochemical properties of the virus, which probably would enhance the possibility of diagnosis of the disease and quantitative calculation of the virus.

X. Summary

1. Mechanical inoculation, some physical properties in sap, isolation and purification of potato leaf-roll virus (PLRV), and the virus localization in plant tissues are described.

2. It was confirmed that PLRV was transmitted by green peach aphids, *Myzus persicae*, injected with the extracts from diseased plants and homogenates or blood from viruliferous aphids.

3. *Aulacorthum solani* also became virus transmitters after injection with extracts from infected plants and viruliferous aphids.

4. The virus appeared to be still infectious after 5 days at 2°C.

5. The dilution end point of the virus appeared to be between 10^{-3} and 10^{-4} .

6. The virus in crude sap appeared to be inactivated between 70 and 80°C.

7. The virus was tolerant against freezing of plant tissue and sap.

8. The virus infectivity remained in the supernatant fraction of extract of the infected plants after being centrifuged at 30,000 rpm (58,000g) for 60 minutes.

9. The virus was tolerant to a chloroform solvent and a mixture of chloroform and *n*-butanol.

10. Normal cell constituents were not completely removed when plant saps treated with a mixture of charcoal and Celite were filtered or centrifuged, followed by the chloroform and *n*-butanol treatment.

11. The virus in clarified sap was sedimented by centrifugation at 40,000 rpm (100,000g) for more 60 minutes, although the virus was also partly pelleted by centrifugation below 100,000g.

12. Electron micrographs and ultraviolet absorption spectra showed that the partly purified preparations contained a large amount of normal cell constituents, despite which they were highly infectious.

13. An extra component was not detected when a concentrated preparation from infected plants was chromatographed on DEAE-cellulose.

14. An extra component was not detected spectrophotometrically after centrifuging an unfractionated infectious preparation layered onto a sucrose density-gradient column. However, a zone 15–21 mm from the tube bottom was associated with infectivity and this infectious zone contained uniform spherical particles (24–25 nm in diameter).

15. The virus was purified by the procedure shown in Chapter VII, which contained clarification with organic solvents (a chloroform and *n*-butanol mixture, and Daiflon S-3), 2 cycles of differential centrifugation and subsequently 2 cycles of sucrose density-gradient centrifugation.

16. Two visible zones were obtained by this procedure. Both zones were associated with infectivity.

17. The bottom fraction contained many uniform spherical or polyhedral particles with some surface structure, but the top fraction consisted of a few spherical particles intermingled with the considerable number of amorphous particles.

18. The fixed virus particles (either in formaldehyde or glutaraldehyde) appeared to have hexagonal outlines.

19. As the size of the fixed particles corresponded with that of the particles suspended and stained under acidic condition, it was concluded that PLRV has hexagonal particles of 25 nm diameter (side to side).

20. The amorphous particles contained in the top fraction appeared to be disrupted virus particles, because these particles had the same surface structure as the virus.

21. PLRV particles were precipitated within sucrose density-gradient column centrifuged in the presence of Mg^{2+} .

22. It was confirmed that the PLRV-isolate used in this investigation was free of any contaminating virus.

23. Infectious virus was also recovered from root tissues of the infected plants, but the preparation contained more impurities than that from leaves.

24. Two attempts to simplify the concentrating procedure of clarified sap for a large scale purification by evaporation and centrifugation onto sucrose cushion did not succeed.

25. Electron microscope examinations of ultrathin sections of infected

plants indicated that the virus was localized in phloem tissue even though in low frequency, but was not found in other tissues.

26. Virus particles were scattered singly or in masses in the network structure of degenerated cells.

27. Also, virus particles were scattered singly throughout the lumen of the cell and interspersed with remnants of cell organelles.

28. Crystalline arrays of the virus particles were rarely seen in the central vacuole of cells of old diseased leaves.

29. Serial sections of these crystalline arrays revealed that they definitely consisted of spherical particles.

30. The particles in crystalline arrays were approximately 23 nm in diameter, which corresponded satisfactorily with that of the virion from purified preparations.

31. There were some necrotic cells adjacent to cells containing PLRV particles.

32. One of them had a uniformly densely staining material throughout a cell of triangle shape, in which no virus particles could be detected.

33. In other necrotic cells, densely staining materials were deposited in the center of the cells, in which no virus particles were found.

34. The necrotic cells with a network of densely staining fibers contained virus particles.

35. The low concentration of PLRV in the sap of infected plants was deduced from the fact that distribution of the virus was restricted to phloem tissues.

XI. References

1. ARAI, K., DOI, Y., YORA, K. and ASUYAMA, H. (1969). *Ann. Phytopath. Soc. Japan* 35: 10-15. (in Japanese).
2. BANCROFT, J. B., HILLS, G. J. and MARKHAM, R. (1967). *Virology* 31: 354-379.
3. BAWDEN, F. C. (1964). *Plant viruses and virus diseases* (4th edition). Ronald Press Company, New York.
4. BILS, R. F., and HALL, C. E. (1962). *Virology* 17: 123-130.
5. BLACK, L. M., and MARKHAM, R. (1963). *Netherlands J. Plant Pathol.* 69: 215.
6. BLACK, L. M., MOSLEY, V. M., and WYCKOFF, R. W. G. (1948). *Biochim. Biophys. Acta* 2: 121-123.
7. BLACK, L. M., SMITH, K. M., HILLS G. J., and Markham, R. (1965). *Virology* 27: 446-449.
8. BOTJES, J. G. O. (1920). *De bladrolziekte van de aardappelplant.* 8: 1-136. H. Veeman en Zonen, Wageningen.
9. BOZARTH, R. F., and CHOW, C. C. (1966). *Contrib. Boyce Thompson Inst.* 23: 301-309.

10. BRAKKE, M. K. (1960). *Adv. Virus Res.* 7: 193-224.
11. BRAKKE, M. K. (1967). In "Methods in Virology" (K. Maramorosch and H. Koprowski, eds.), Vol. II: 93-118. Academic Press, New York.
12. BRAKKE, M. K. (1967). In "Methods in Virology" (K. Maramorosch and H. Koprowski, eds.), Vol. II: 119-136. Academic Press, New York.
13. BRAKKE, M. K., BLACK, L. M., and WYCKOFF, R. W. G. (1951). *Amer. J. Bot.* 38: 332-342.
14. BRAKKE, M. K., VATTER, A. E., and BLACK, L. M. (1954). *Abnormal and Pathological Plant Growth. Brookhaven symposia in biology No. 6*: 137-156.
15. BRANDENBURG, E. (1962). *Phytopath. Z.* 43: 420-404.
16. BROWN, F., and CARTWRIGHT, B. (1959). *Biochim. Biophys. Acta* 33: 342-346.
17. BROWN, F., CARTWRIGHT, B., CRICK, J., and SMALE, C. J. (1967). *J. Virology* 1: 362-373.
18. CORBETT, M. K. (1961). *Virology* 15: 8-15.
19. CORBETT, M. K., and ROBERTS, D. A. (1962). *Phytopath.* 52: 902-905.
20. CROWLEY, N. C., HARRISON, B. D., and FRANKI, R. I. B. (1965). *Virology* 27: 290-296.
21. DAY, M. F. (1955). *Aust. J. Biol. Sci.* 8: 498-513.
22. DAY, N. F., and ZAITLIN, M. (1958). *Phytopath. Z.* 34: 83-85.
23. DUFFUS, J. E. (1963). *Virology* 21: 194-202.
24. DUFFUS, J. E., and GOLD, A. H. (1965). *Virology* 27: 388-390.
25. ERIKSON, R. L. (1969). *Virology* 37: 124-131.
26. ESAU, K., and CRONSHAW, J. (1967). *Virology* 33: 26-35.
27. FRANCKI, R. I. B., RANGLES, J. W., CHAMBERS, T. C., and WILSON, S. B. (1966). *Virology* 28: 729-741.
28. FUKUSHI, T. (1946). *Seibutsu* 1: 37-41. (in Japanese).
29. FUKUSHI, T., and KIMURA, I. (1959). *Proc. Japan Acad.* 35: 482-484.
30. FUKUSHI, T., and SHIKATA, E. (1963). *Virology* 21: 500-503.
31. FUKUSHI, T., SHIKATA, E., and KIMURA, I. (1962). *Virology* 18: 192-205.
32. FUKUSHI, T., SHIKATA, E., KIMURA, I., and NEMOTO, M. (1960). *Proc. Japan Acad.* 36: 352-357.
33. FULTON, R. W. (1959). *Virology* 9: 522-535.
34. GÁLVEZ, G. E. (1964). *Virology* 23: 307-312.
35. GÁLVEZ, G. E. (1968). *Virology* 35: 418-426.
36. GIBBS, A. J. (1969). *Adv. Virus Res.* 14: 263-328.
37. GIBBS, A. J., HARRISON, B. D., and WOODS, R. D. (1966). *Virology* 29: 348-351.
38. GIBBS, A. J., NIXON, H. L., and WOODS, R. D. (1963). *Virology* 19: 441-449.
39. GOMATOS, P. J., and TAMM, I. (1963). *Proc. Nat. Acad. Sci. U. S.* 50: 878-885.
40. GOVIER, D. A. (1963). *Virology* 19: 561-564.
41. HARIHARASUBRAMANIAN, V. (1964). *Phytopath. Z.* 49: 393-400.
42. HARRISON, B. D. (1958). *Virology* 6: 265-277.
43. HARRISON, B. D., and CROWLEY, N. C. (1965). *Virology* 26: 297-310.
44. HARUNA, I., YAOI, H., KANO, R., and WATANABE, I. (1961). *Virology* 13: 264-267.

45. HEAGY, J., and ROCHOW, W. F. (1965). *Phytopath.* 55: 809-810.
46. HEINZE, K. (1955). *J. econ. Entom.* 48: 751.
47. HEINZE, K. (1955). *Phytopath. Z.* 25: 103-108.
48. HEROLD, E., and MUNZ, K. (1965). *Virology* 25: 412-417.
49. HEROLD, F., and MUNZ, K. (1967). *J. gen. Virology* 1: 227-234.
50. HEROLD, F., BERGOLD, G. H., and WEIBEL, J. (1960). *Virology* 12: 335-347.
51. HIEBERT, E., and BANCROFT, J. B. (1969). *Virology* 39: 296-311.
52. HILLS, G. J., and PLASKITT, A. (1968). *J. Ultrastructure Res.* 25: 323-329.
53. HORI, S. (1920). *Byochugai-Zasshi* 7: 667-671. (in Japanese).
54. HULL, R., and JOHSON, M. W. (1968). *Virology* 34: 388-390.
55. HULL, R., HILLS, G. J., and MARKHAM, R. (1969). *Virology* 37: 416-428.
56. IZADPANAH, K., and SHEPHERD, R. J. (1966). *Virology* 28: 463-476.
57. JENSEN, S. G. (1969). *Virology* 38: 83-91.
58. KAPER, J. M. (1968). In "Molecular Basis of Virology" (H. Fraenkelconrat, ed.), pp. 82. Reinhold Book Corporaton.
59. KAPER, J. M. (1971). *J. Mol. Biol.* 56: 259-276.
60. KASAI, M. (1922). *Berichte Ohara Inst. f. Landwirtsch. Forsch.* 2: 47-77.
61. KENNEDY, J. S., DAY, M. F., and EASTOP, V. F. (1962). A conspectus of aphids as vectors of plant viruses. Eommonwelth Institute of Entomology.
62. KIMURA, I., and FUKUSHI, T. (1960). *Ann. Phytopath. Soc. Japan* 25: 131-135. (in Japanese).
63. KIMURA, I., and SHIKATA, E. (1968). *Proc. Japan Acad.* 44: 538-543.
64. KIMURA, I., and SUZUKI, N. (1965). *Shokubutsu-boeki (Plant Protection)* 19: 137-140. (in Japanese).
65. KIRKPATRICK, H. C. (1948). *Amer. Potato J.* 25: 283-290.
66. KITANI, K., and KISO, A. (1960). *Bull Shikoku Agric. Exp. Stn.* 18: 101-116. (in Japanese).
67. KITAGAWA, Y., and SHIKATA, E. (1969). *Mem. Fac. Agriculture Hokkaido Univ.* 6 (4): 446-451. (in Japanese).
68. KLEMPERER, H. G., and PEREIRA, H. G. (1959). *Virology* 9: 536-545.
69. KODAMA, T. (1968). *Biological techniques I. Zoku-Seibutsu-Butsuri-Koza* 4, Yoshida Shoten. pp. 431-462. (in Japanese).
70. KOJIMA, M., SHIKATA, E., SUGAWARA, M., and MURAYAMA, D. (1968). *Virology* 35: 612-615.
71. KOJIMA, M., SHIKATA, E., SUGAWARA, M., and MURAYAMA, D. (1969). *Virology* 39: 162-174.
72. KÖNIG, R. (1964). *Dissert. Abst.* 24 (12. Pt. 1): 4903.
73. KÖNIG, R., and MUELLER, W. C. (1964). *Phytopath.* 54: 1223-1227.
74. KUSHIDA, H., and FUJITA, K. (1967). *J. Electron Microscopy* 16: 323-329.
75. LEE, P. E. (1964). *Virology* 23: 145-151.
76. LEE, P. E. (1967). *Virology* 33: 84-94.
77. LEE, P. E. (1968). *Virology* 34: 583-589.
78. LINDNER, R. C., KIRKPATRICK, H. C., and WEEKS, T. E. (1955). *Phytopath.* 45: 574-576.

79. LING, K. C. (1966). *Phytopath.* 56: 1252-1256.
80. LOVISOLO, O., and CONTI, E. M. (1966). *Atti. Accad. Sci. Torino Classe Sci. Fis. Mat. Nat.* 100: 62-72.
81. LOVISOLO, O., LUISONI, E., CONTI, E. M., and WETTER, C. (1967). *Naturwissenschaften* 54: 73-74.
82. LU, Y. T., SHIKATA, E., and MURAYAMA, D. (1968). *Mem. Fac. Agr. Hokkaido Univ.* 6 (3): 335-339. (in Japanese).
83. MACLEOD, R., BLACK, L. M., and MOYER, F. H. (1966). *Virology* 29: 540-552.
84. MCLEAN, G. D., and FRANCKI, R. I. B. (1967). *Virology* 31: 585-591.
85. MILNE, R. (1966). *Virology* 28: 79-89.
86. MIURA, K., KIMURA, I., and SUZUKI, N. (1966). *Virology* 28: 571-579.
87. MIYAMOTO, S., and MIYAMOTO, Y. (1966). *Science Reports of the Hyogo University of Agriculture* 7: 51-66. (in Japanese).
88. MOERICKE, V. (1961). *Z. Pflanzenkrank. u. Pflanzensch.* 68: 581-587.
89. MOERICKE, V. (1963). *Z. Pflanzenkrank. u. Pflanzensch.* 70: 464-470.
90. MUELLER, W. C., and ROSS, A. F. (1961). *Amer. Potato J.* 38: 249-258.
91. MURANT, A. F. (1965). *Virology* 26: 538-544.
92. MURAYAMA, D., and KOJIMA, M. (1963). *Ann. Phytopath. Soc. Japan* 28: 85-86. (Abstr. in Japanese).
93. MURAYAMA, D., and KOJIMA, M. (1964 a). *Ann. Phytopath. Soc. Japan* 29: 78. (Abstr. in Japanese).
94. MURAYAMA, D. and KOJIMA, M. (1964 b). *Ann. Phytopath. Soc. Japan* 29: 279. (Abstr. in Japanese).
95. MURAYAMA, D., and KOJIMA, M. (1965 a). *Ann. Phytopath. Soc. Japan* 30: 20-23. (in Japanese).
96. MURAYAMA, D., and KOJIMA, M. (1965 b). *Ann. Phytopath. Soc. Japan* 30: 209-215.
97. MURAYAMA, D., KOJIMA, M., and SUGAWARA, M. (1967). *Ann. Phytopath. Soc. Japan* 32: 98. (Abstr. in Japanese).
98. NAGARAJ, A. N., and BLACK, L. M. (1961). *Virology* 15: 289-294.
99. NAGARAJ, A. N., SHINHA R. C., and BLACK, L. M. (1961). *Virology* 15: 205-208.
100. O'LOUGHLIN, C. T., and CHAMBERS, T. C. (1967). *Virology* 33: 262-271.
101. PETERS, D. (1965). *Virology* 26: 159-161.
102. PETERS, D. (1967 a). *Virology* 31: 46-54.
103. PETERS, D. (1967 b). *Meded. L. E. B. Fonds No. 45. Veenman and Zonen, Wageningen, The Netherlands.*
104. PHILIPSON, L. (1967). *In "Methods in Virology"* (K. Maramorosch., and H. Koprowski, eds.), Vol. II: 179-233. Academic Press, New York.
105. PHILIPSON, L. (1967). *In "Methods in Virology"* (K. Maramorosch., and H. Koprowski, eds.), Vol. II: 235-244. Academic Press, New York.
106. PRICE, W. C. (1946). *Amer. J. Bot.* 33: 45-54.
107. QUANJER, H. M., VAN DER LEK, H. A. A., and Botjes, J. O. (1961). *Meded. van de Landbouwhoogeschool* 10: 1-138.
108. RICHARDSON, J., and SYLVESTER, E. S. (1965). *Virology* 25: 472-475.

109. RICHARDSON, J., and SYLVESTER, E. S. (1968). *Virology* 35: 347-355.
110. ROCHOW, W. F., and BRAKKE, M. K. (1964). *Virology* 24: 310-322.
111. SARKAR, S. (1963). *Virology* 21: 510-513.
112. SATO, T., KYOGOKU, Y., HIGUCHI, S., MITSUI, Y., IITAKE, Y., TSUBOI, M., and MIURA, K. (1966). *J. Mol. Biol.* 16: 180-190.
113. SCHLITZ, E. S., and FOLSOM, D. (1921). *J. Agr. Res.* 21: 47-80.
114. SCHNEIDER, I. R. (1953). *Science* 117: 30-31.
115. SCOTT, H. (1963). *Virology* 20: 103-106.
116. SHEPHERD, R. J., and POUND, G. S. (1960). *Phytopath.* 50: 797-803.
117. SHEPHERD, R. J., WAKEMAN, R. J., and GHABRIAL, S. A. (1968). *Virology* 35: 255-267.
118. SHIBATA, K. (1962). *Shyokubutsu-Boeki (Plant Protection)* 16: 281-282. (in Japanese).
119. SHIKATA, E. (1966). *J. Fac. Agr., Hokkaido Univ.* 55: 1-110.
120. SHIKATA, E. (1968). In "The Virus Diseases of the Rice Plant" pp. 223-240. Johns Hopkins Press.
121. SHIKATA, E. (1969). In "Viruses, Vectors, and Vegetation" (K. Maramorosch, ed.), pp. 393-415. Interscience Publishers.
122. SHIKATA, E., and CHEN, M. J. (1969). *J. Virology* 3: 261-264.
123. SHIKATA, E., and LU, Y. T. (1967). *Proc. Japan Acad.* 43: 918-923.
124. SHIKATA, E., and MARAMOROSCH, K. (1965). *Virology* 27: 461-475.
125. SHIKATA, E., and MARAMOROSCH, K., (1966). *Virology* 30: 439-454.
126. SHIKATA, E., MARAMOROSCH, K., and GRANODOS, R. (1966). *Virology* 29: 426-436.
127. SHIKATA, E., ORENSKI, S. W., HIRUMI, H., MITSUHASHI, J., and MARAMOROSCH, K. (1964). *Virology* 23: 441-444.
128. STEERE, R. L. (1956). *Phytopath.* 46: 60-69.
129. STEERE, R. L. (1959). *Adv. Virus Res.* 6: 3-73.
130. STEGWEE, D. (1960). *Proceed. 4th Confer. Potato Virus Dis.* Branschweig, pp. 12-17.
131. STEGWEE, D., and PETERS, D. (1961). *Virology* 15: 202-203.
132. STEGWEE, D., and PONSEN, M. B. (1958). *Entom. Exp. Appl.* 1: 291-300.
133. STOREY, H. H. (1933). *Proc. Roy. Soc. (London) Ser. B.* 113: 463-485.
134. STUBBS, L. L., and GROGAN, R. G. (1963). *Australian J. Agr. Res.* 14: 439-459.
135. SUGIMOTO, T., MURAYAMA, D., and SANAI, S. (1970). *Bulletin of Sugar Beet Research* 8: 1-163. (in Japanese).
136. SYLVESTER, E. S. (1969). *Virology* 38: 440-446.
137. SYLVESTER, E. S. (1969). In "Viruses, Vectors, and Vegetation" (K. Maramorosch, ed.), pp. 150-173. Interscience Publishers.
138. SYLVESTER, E. S., and RICHARDSON, J. (1969). *Virology* 27: 26-31.
139. TAKANAMI, Y., and TOMARU, K. (1969). *Virology* 37: 293-295.
140. TAMADA, T. (1970). *Ann. Phytopath. Soc. Japan* 36: 266-274.
141. TAMADA, T. GOTO, T., CHIBA, I., and SUWA, T. (1969). *Ann. Phytopath. Soc. Japan* 35: 282-285. (in Japanese).
142. TOMLINSON, J. A. (1963). *Nature* 200: 93-94.

143. TOYODA, S., KIMURA, I., and SUZUKI, N. (1965). *Ann. Phytopath. Soc. Japan* 30: 225-230.
144. WATSON, M., SERJEANT, E. P., and LENNON, E. A. (1964). *Ann. appl. Biol.* 54: 153-166.
145. WELLS, J. M., and SISLER, H. D. (1969). *Virology* 37: 227-236.
146. WHITCOMB, R. F. (1964). *Virology* 24, 488-492.
147. WHITCOMB, R. F., and BLACK, L, M, (1961). *Virology* 15: 136-145.
148. WILSON, D. E. (1962). *J. Bacteriol.* 84: 295-301.

Explanation of plates**Plate I.**

- A. An electron micrograph of virus-like particles from the infectious zone of the sucrose density-gradient column. Shadowed with tungsten oxide. $\times 50,000$.
- B, C. Negatively stained virus-like particles isolated from diseased *Physalis floridana* plants. The particles were fixed in 1% formaldehyde before staining in 2% PTA (pH 7.0). $\times 200,000$
- D. Negatively stained particles isolated from diseased *P. floridana* plants. Spherical particles (arrow) are observed intermingled with a considerable number of amorphous precipitate. The particles were stained with 2% PTA (pH 7.0). $\times 50,000$.

Plate II.

- A. An electron micrograph of PLRV from the bottom zone of a sucrose density-gradient column. The final preparation was suspended in 0.01 M phosphate buffer (pH 7.4) and negatively stained with 2% PTA (pH 7.0). $\times 100,000$.
- B. An enlarged view of a part shown in A. Note that virus particles show some surface structures. $\times 200,000$.
- C. An electron micrograph of particles from the top zone of a sucrose density-gradient column. A few virus particles are observed intermingled with a considerable amount of amorphous precipitate or disrupted virus particles. $\times 100,000$.
- D. An electron micrograph of the purified virus particles. The preparation was suspended in 0.01 M phosphate buffer (pH 6.0) and negatively stained with 2% PTA (pH 5.5). $\times 200,000$.
- E. Do. The preparation was fixed in 1% glutaraldehyde before staining with 2% PTA (pH 5.5). $\times 300,000$.

Plate III.

- A. An electron micrograph of a preparation from the "virus zone" of the sucrose density-gradient column on which extracts from virus-free green peach aphids were layered. No virus-like particles are observed. $\times 100,000$.
- B. An electron micrograph of particles from the "virus zone" of the sucrose density-gradient column under the presence of magnesium ion. Many small particles appear to be the aggregated ribosomes of *P. floridana* plants. $\times 100,000$.
- C. An electron micrograph of particles from the root tissues of diseased *P. floridana* plants. A few virus particles (arrow) are observed intermingled with a large amount of contaminants. The particles were stained with 2% PTA (pH 5.5). $\times 100,000$.

- D. An electron micrograph of particles contained in the sucrose cushion. Virus particles from the upper part (20% sucrose) of the cushion. $\times 100,000$.
- E. Do. Virus particles from the lower part (70% sucrose) of the cushion. $\times 100,000$.

Plate IV.

- A. A transverse section of a phloem cell of a PLRV-infected *P. floridana* plant. Virus particles (V) are scattered in the network structure of a degenerated cell. $\times 50,000$.
- B. Do. Virus particles scattered in cytoplasm of a degenerated phloem cell. V, virus particles; S, starch grain. $\times 50,000$.
- C. An ultrathin section of degenerated phloem cell in which virus particles (V) are loosely accumulated. $\times 50,000$.

Plate V.

- A. An ultrathin section of a phloem cell of an old infected *P. floridana* plant. Virus microcrystals occur in the central vacuole of the sieve tube. The cytoplasm is at the periphery of the cell. M, mitochondrion. $\times 50,000$.
- B. An ultrathin section of a phloem cell of an infected *Datura stramonium* plant. Note the clear round uniform profiles of the virions which occur freely scattered in the vacuole and beside the cell wall (upper right). $\times 50,000$.

Plate VI.

- A. An enlarged view of the virus crystals in one of the serial sections of a cell. Note that some of the virions show hexagonal profiles. $\times 100,000$.

Plate VII.

- A. An ultrathin section of a phloem tissue of a leaf from an infected *D. stramonium* plant. An accumulation of the virus particles (arrow) occur in the vacuole of a phloem cell. n, necrotic cell. $\times 5,500$.
- B. An enlarged view of the part indicated by arrow in A showing a large accumulation of PLRV (V). $\times 50,000$.
- C. An ultrathin section of a phloem cell of a leaf from an infected *P. floridana* plant. Note that a mass of the phloem proteins (P) with tubular structure occur in the vacuole of a phloem cell. N, nucleus. $\times 50,000$.

Plate VIII.

- A. An ultrathin section of a degenerated (necrotic) phloem cell in which virus particles (V) still occur. S, starch grain. $\times 50,000$.

- B. An ultrathin section of a degenerated (necrotic) phloem cell in which it is difficult to detect the virions due to osmiophilic substances. S, starch grain. $\times 50,000$.
- G. An ultrathin section of another type of necrotic phloem cell. Note that no virus particles and cell organelles are observed in the cell showing a triangle shape. $\times 50,000$.

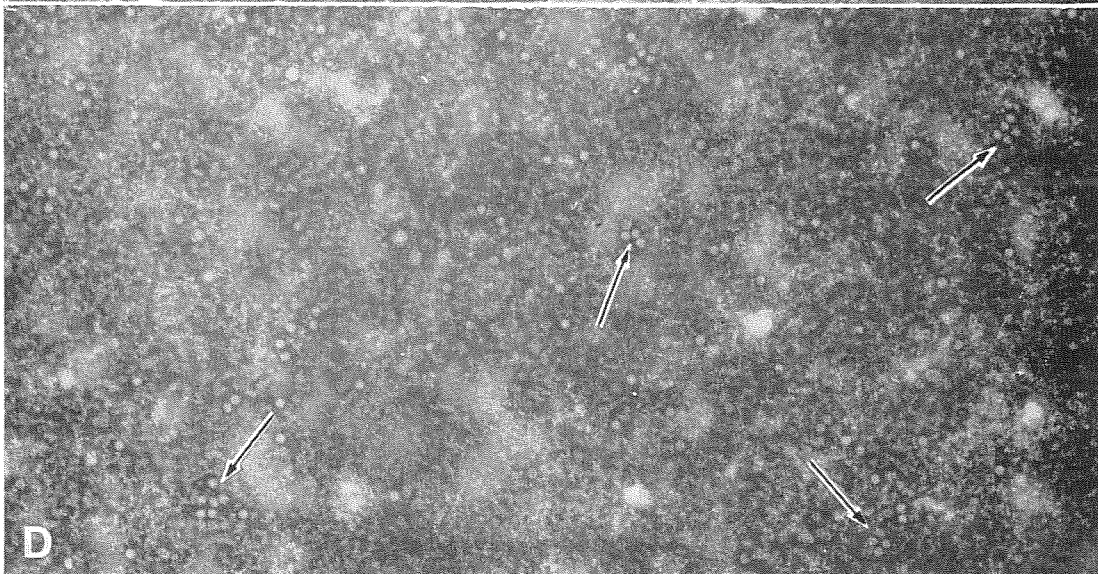
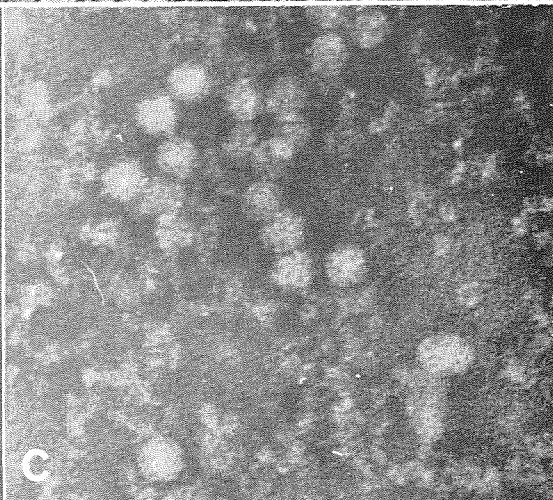
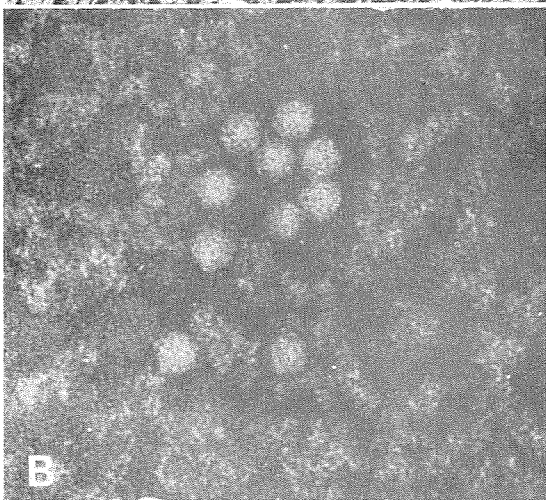
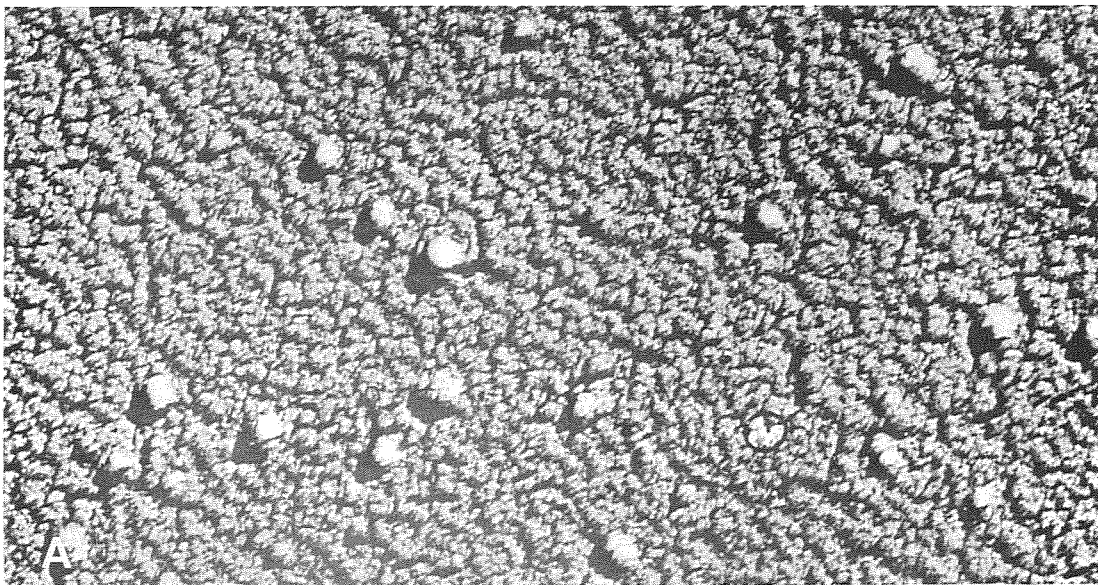

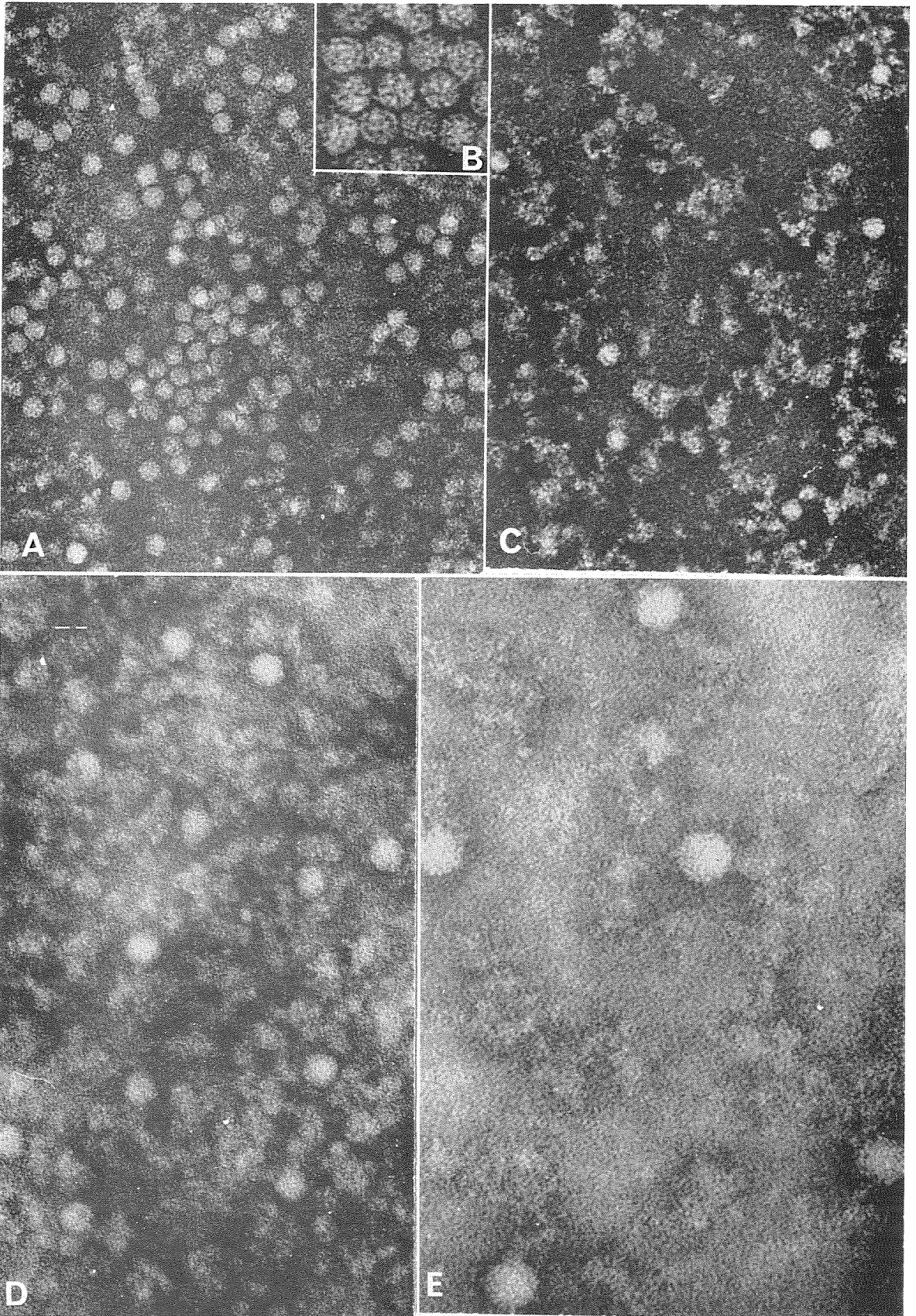

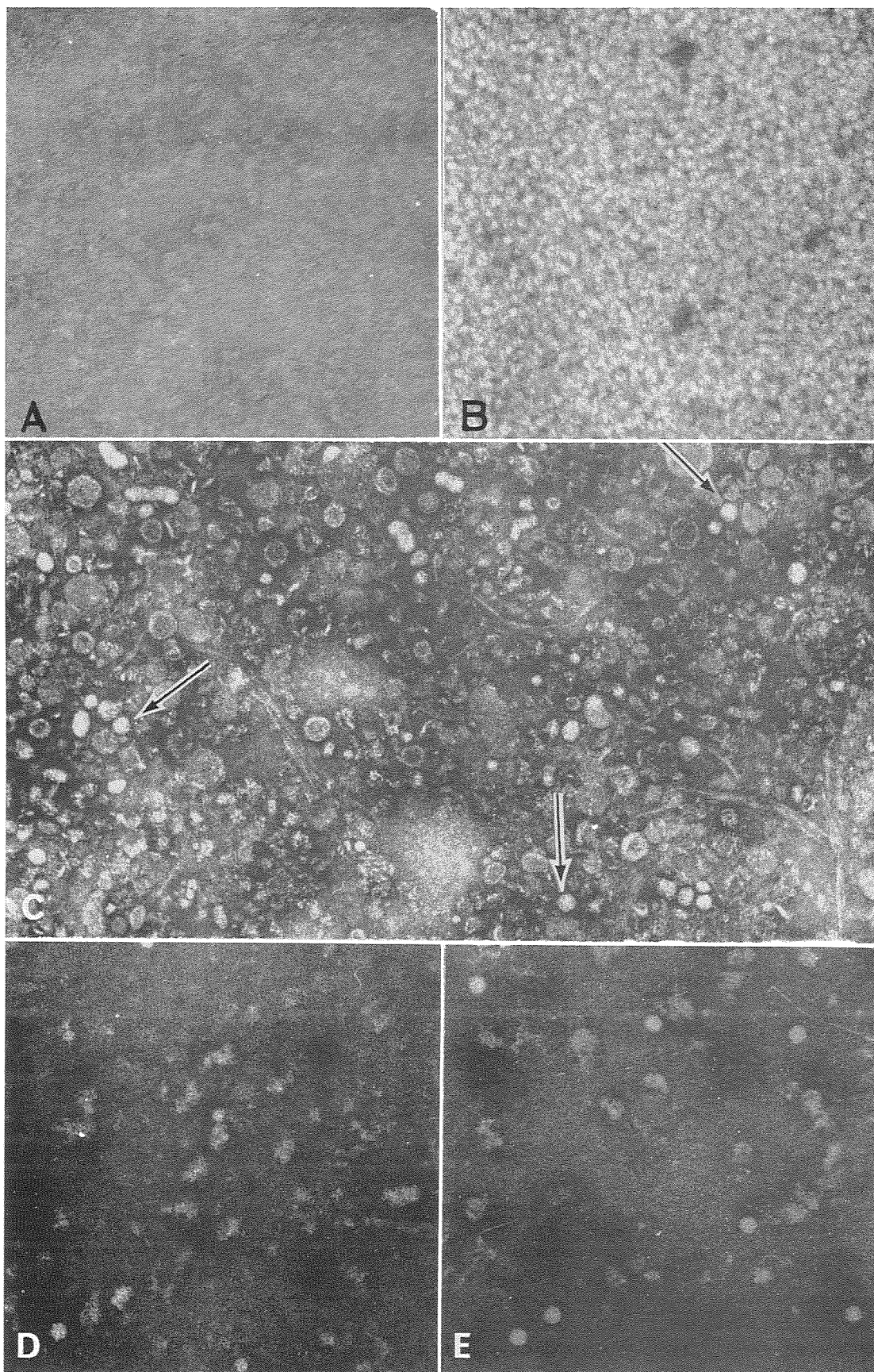

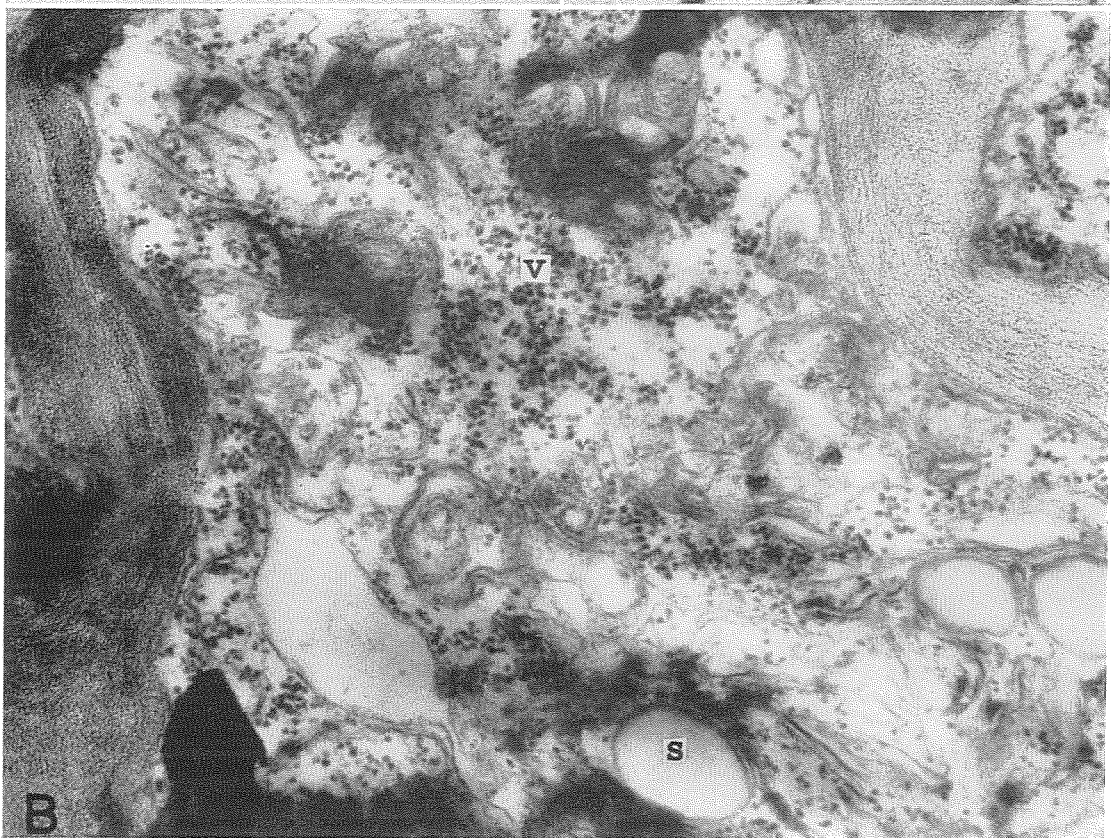
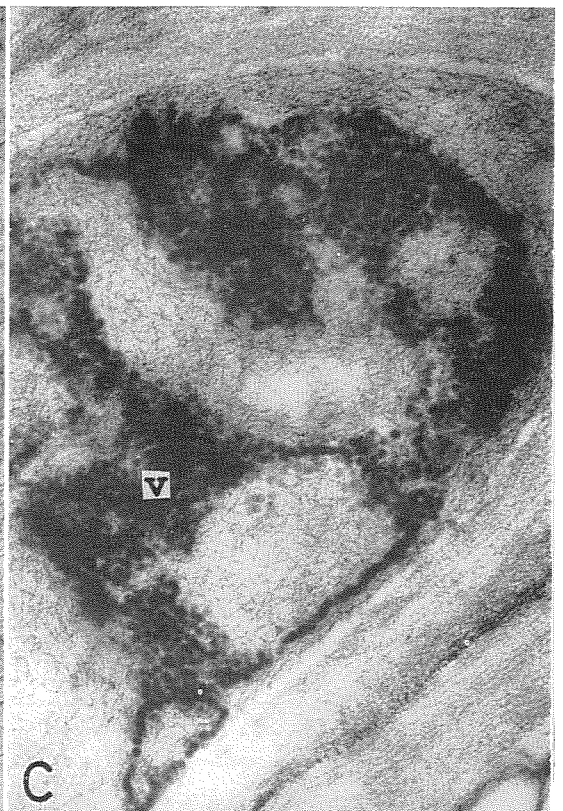
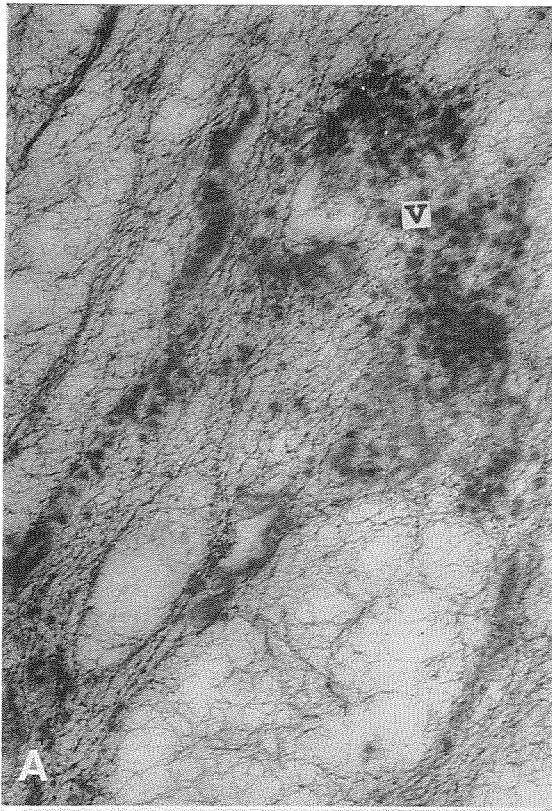

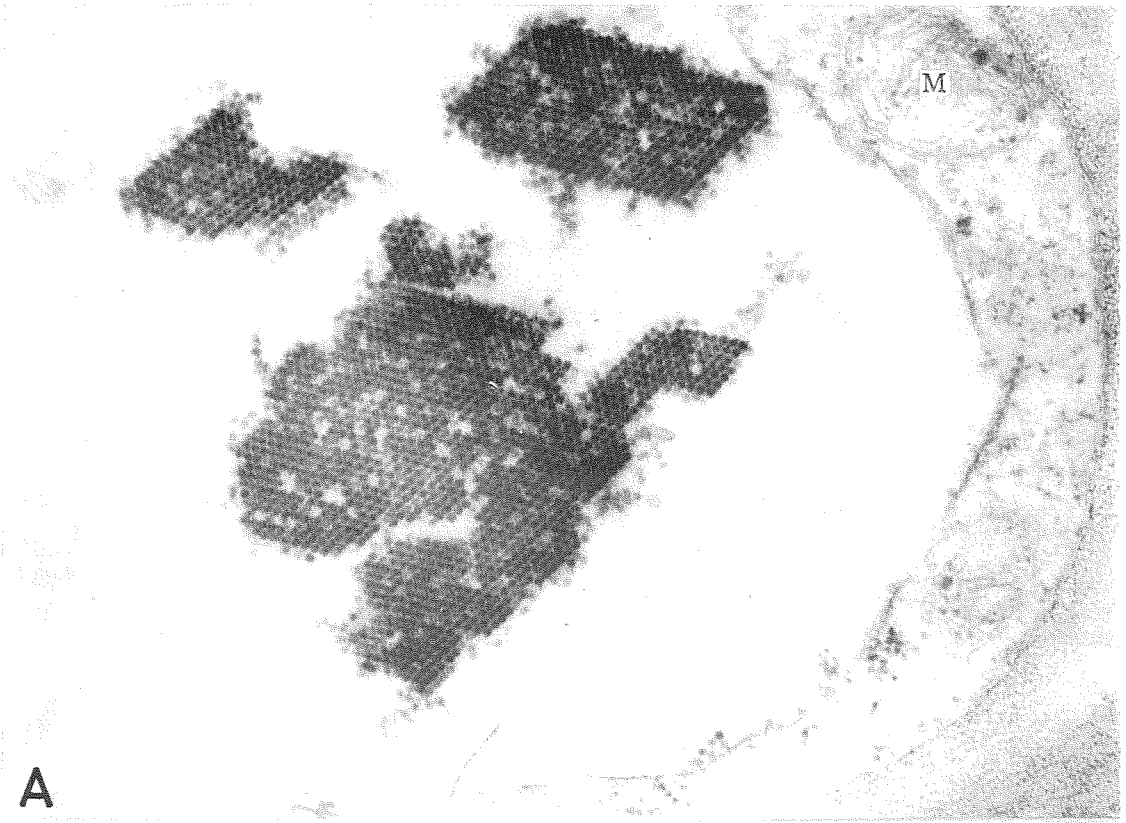

A

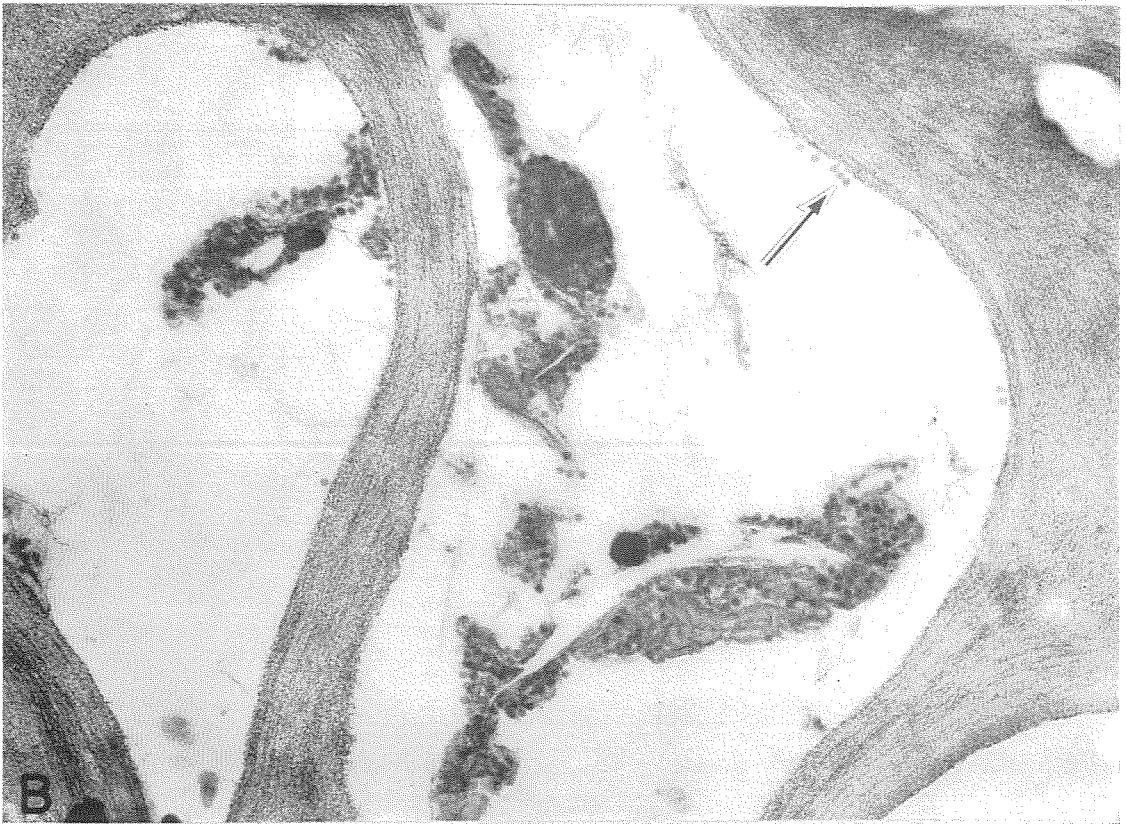

B

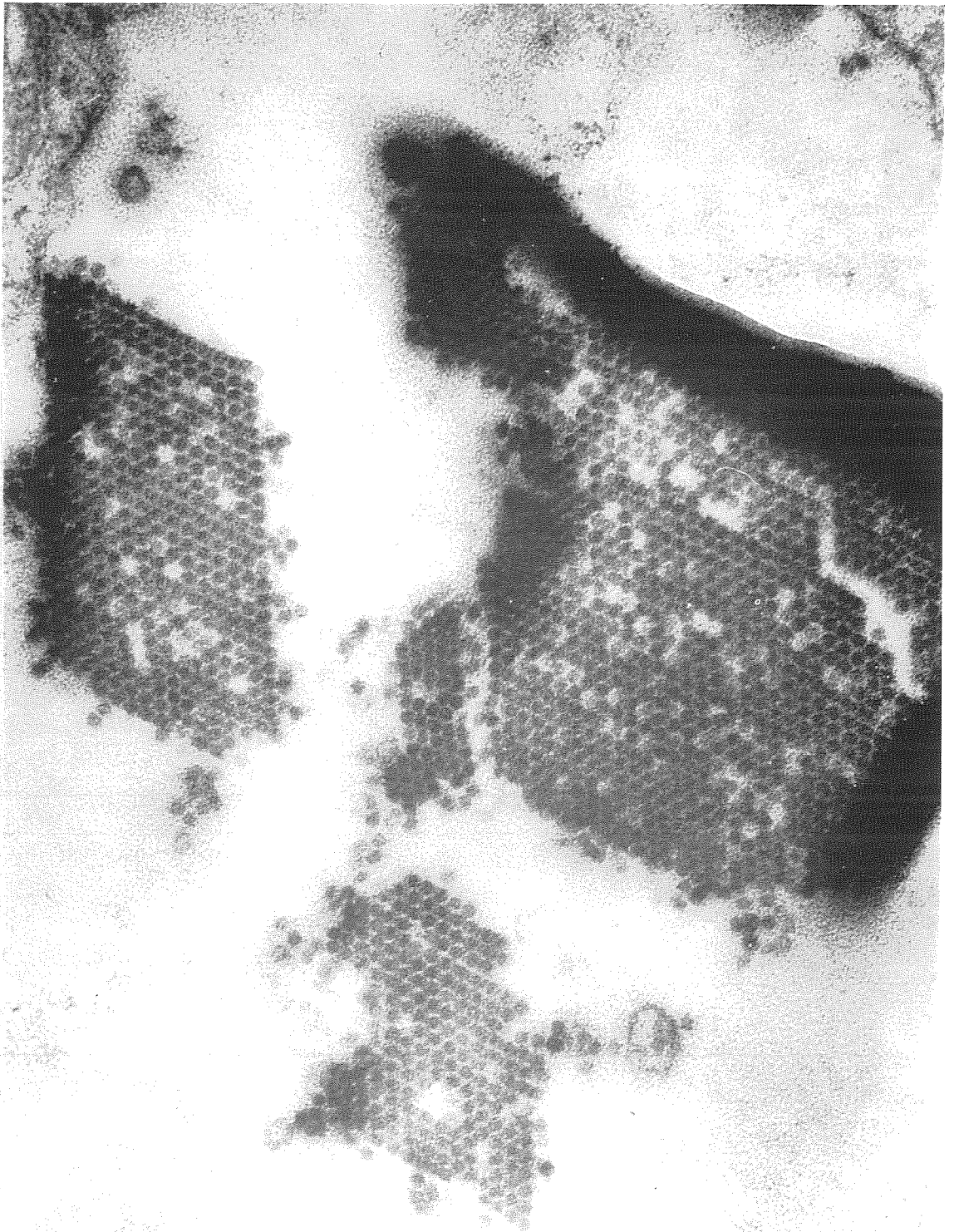

A

