



HOKKAIDO UNIVERSITY

Title	TILLAGE OPERATIONS BY RUBBER-TRACKED TRACTOR WITH HYDRO-STATIC DRIVE
Author(s)	HATA, Shun-ichi; TAKAI, Munehiro; SAKAI, Kenshi et al.
Citation	Journal of the Faculty of Agriculture, Hokkaido University, 65(3), 229-237
Issue Date	1992-03
Doc URL	https://hdl.handle.net/2115/13117
Type	departmental bulletin paper
File Information	65(3)_p229-237.pdf



TILLAGE OPERATIONS BY RUBBER-TRACKED TRACTOR WITH HYDRO-STATIC DRIVE

Shun-ichi HATA, Munehiro TAKAI, Kenshi SAKAI and Satoru NAMBU

Department of Agricultural Engineering, Faculty of Agriculture,
Hokkaido University, Sapporo 060, Japan

(Received October 14, 1991)

Introduction

A major cause of soil compaction in agricultural soil is considered wheel traffic. The use of tracks instead of tires in agricultural tractors has the potential of reducing soil compaction because of reduced surface contact pressure and uniform load distribution over a relatively long track^{1,2)}. Tracked tractors also have the advantage of developing high dynamic traction ratios. In the past, steel-tracked tractors were replaced with large 4-wheel drive tractors, because of their greater mobility and higher traveling speeds.

With the introduction of rubber tracks and new technology, tracked tractors are now coming back in agricultural activities. In 1988, Caterpillar Inc., introduced the rubber-tracked tractor. This tractor is rated as an "Ultra Large" tractor, with a 191kW engine and 16050kg of operating weight. It has greater mobility than the predecessors and has the general characteristics of low ground pressure and large draft force.

Other makers are following the lead of Caterpillar. In 1990, Track Marshall, Britain's oldest crawler maker, and Morooka Co., Ltd. of Japan have developed hydro-static driven rubber tracked tractors, which incorporate all the advanced engineering and technology of the present day.

It is the focus of this paper to reevaluate tracked tractors for use in agricultural tillage operations. For this project, a model MCT-250 was supplied by Morooka.

Machine Description

An outline of the model MCT-250 is given in Table 1. The tractor was equipped with a turbo charged 184kw engine. Engine power is directly routed off to the two variable delivery hydraulic swash plate pumps and onward to the two wheel motors. The wheel motors are equipped with reduction gears of 1/27. The maximum hydraulic pressure is 34MPa. The speed controls, which also control forward and reverse and steering, are achieved by two hydraulic drive levers in front of an operator. They are conveniently located so that a operator can control the movement of the tractor with one hand. The maximum speed of the

Table 1 Specifications of Tested Tractor
MOROOKA MCT250

Dimensions:	
Length/Width/Height	4345/2500/2800mm
Ground clearance	450mm
Total Mass	6150kg
Engine:	
Model No.	Komatsu SA6D108
Type	Turbocharged Diesel Engine with Inter-cooler
Max. Output	184kW / 2500rpm
Displacement	7150cc
Tracks:	
Type	Rubber Belt encased steel wire
Drives	Hydro-Static Transmission 2 Pumps, 2 Wheel-Motors Max. Pressure: 34MPa
Width/Length	700/6900mm
Crawler Base	2400mm
Max. Speed	15km/hr
Power Take-off:	
Type	1-3/4in. dia. 6-splines
Drive	Mechanical Drive
Rated Speed	540rpm/2500rpm engine

tractor is 15km/h in either forward or reverse.

The rubber tracks are 700mm in width and crawler base is 2400mm. The tracks consist of steel wires encased in highly durable rubber. The belts are driven by drive sprockets. The total weight of the tractor is 6150kg, with a ground pressure of 15kPa. In comparison to other agricultural tracked tractor, the ground pressure is remarkably low.

The 6-splines standard PTO is mechanically driven at rated speed of 540rpm through a wet disc integral clutch.

Measuring Instruments and Procedure

Six transducers were used to measure the dynamic performance of the tractor. Fig.1 shows an outline of the installation of these devices. In the drawbar tests, a drawbar pull was measured by the load cell with a capacity of 10 tons. The fuel flow meter generates a pulse for each 10cc of fuel used. The displacement of the left crawler's swash plate was measured by a linear potentiometer. The engine tachometer was mounted through a splitter gear box to the cam shaft and generated 3 pulses per round. The speed of each crawler was measured by proximity switches that detect teethes of drive sprockets. Real ground speed was measured by a radar speed sensor. The outputs from these sensors were recorded on a data recorder and imported into a computer through A/D converter and pulse counters.

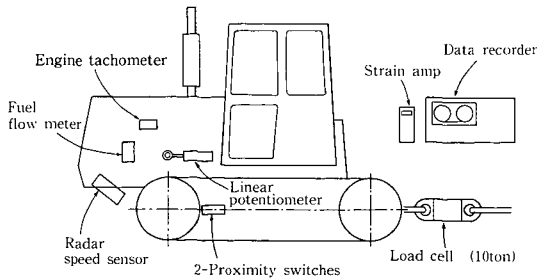

Fig.1 Measuring instruments.

All tests were conducted at 'Sugano White Farm' in Kami-Furano, Hokkaido, on a clay loam soil. Research sites consisted of an oat stubble field and a permanent grassland.

Results and Discussion

1. Drawbar performance

Drawbar performance tests were conducted to determine the basic dynamic performance of the tractor. For this test a John Deer 3350, 4-wheel driven tractor was used as a loading car. The stubble field was pulverized and leveled by a rolling harrow. The cone indexes of the test fields were 0.5-0.7 MPa in the stubble field and exceeded the measuring capacity of our equipment (3MPa) in the grassland.

The results of the drawbar pulls are given in Fig.2. In the stubble field, the maximum continuous drawbar pull of 50kN was achieved with 15% slip. This translates into a traction coefficient of 83%. This figure is remarkably greater than that of steel-tracked tractors (67%) and 4-wheel drive tractors (56%)³⁾. The black dots and broken line in Fig.2 indicate when the tractor was in an overload condition. This would cause the relief valves in either the left or right hydraulic drive to work. In such cases the maximum drawbar pull was 56kN and the coefficient of traction was about 93%.

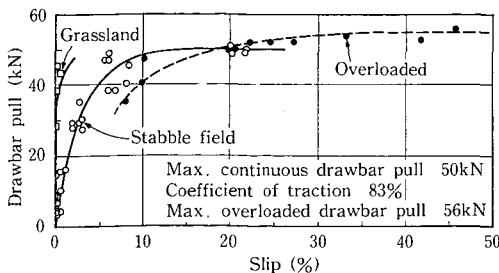

Fig.2 Results of drawbar tests.

Engine power was estimated by the amount of reduction in engine speed and engine performance curve. The amount of power that was exerted on the drive sprocket, was estimated by the draft force and the average speed of both crawlers. By using the above two estimates, the efficiency of hydro-static drive was also estimated.

In the grassland test, the loading car was not able to load sufficiently, because of the soil conditions. A maximum pull of 46kN and coefficient of traction of 76% were obtained. This is quite a bit less than the result achieved in the stubble field test. Considering the Caterpillar CHAL-

LENGER 65, rubber-tracked tractor, achieved a coefficient of traction of 92% with 13% slippage on a concrete track⁴⁾, if we could loaded sufficiently to obtain 10-15% slippage in grassland tests, the drawbar performance higher than the stubble field could be obtained.

2. Efficiency of the Hydro-static Drive

The speed of the left crawler, in the drawbar tests, is illustrated in Fig.3. The crawler speed was determined by the engine speed N , the displacement ratio of the hydraulic pump V/V_{max} and volumetric efficiency η_v . The displacement ratio can be varied by the hydraulic drive lever in this tractor. The crawler speed would be proportional to $N \cdot V/V_{max}$, if η_v was a constant. Generally in a hydraulic system, a volumetric efficiency is decreased, as a load is increased and a displacement ratio is decreased. Therefor, the crawler speed was not proportional only to $N \cdot V/V_{max}$, as shown in Fig.3. This fact shows the necessity of the real ground speed meter for hydro-static drive tractor.

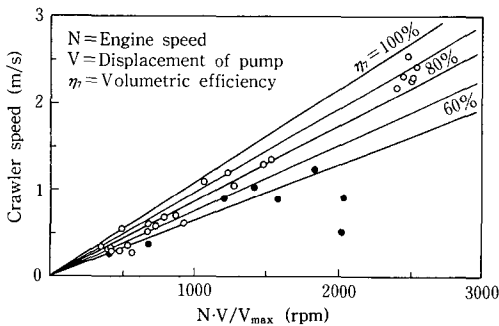

Fig. 3 Speed of left crawler.

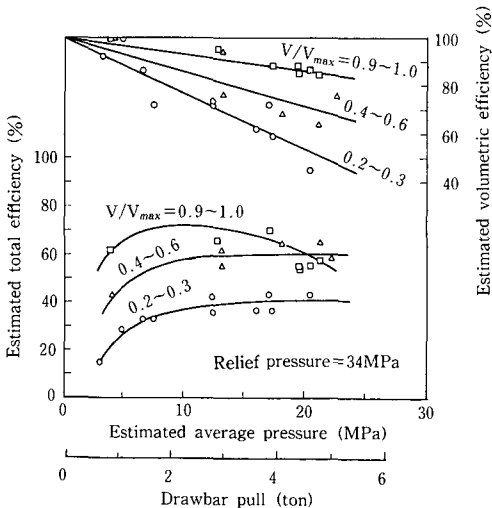

Fig. 4 Estimated efficiency of hydro-static drive.

The efficiency of hydro-static drive was estimated from drawbar tests and is outlined in Fig.4. Data that was collected when the tractor was in a overload condition was not plotted. Estimated average pressure was derived from drawbar pull. Data for the volumetric efficiency was derived from the left crawler only.

Therefore, when the data is plotted it gives a very scattered reading, but it dose show the general characteristics of the variable delivery swash plate pump. When the tractor is in a heavy tractive situations, to slow down a traveling speed only by hydraulic drive levers, i.e. by reducing displacement ratio, will cause a reduction in the efficiency of the hydraulic system. For example, of V/V_{max} is 0.3 and drawbar pull is 5 tons, the volumetric and total efficiency are lowered to 50% and 40% respectively.

3. Working tests

1) Plowing

The working test for the mounted

plow was carried out in the stubble field. Field conditions were not ideal, because of rain that had fallen in the previous night. The water content of surface soil was about 30% d. b. . In these conditions even a 4 wheel drive tractor could not be used. The plow used was a integral-mounted 2-24inch moldboard plow. The plow was also equipped with a plastic moldboard, cover-board and moldboard extension.

The results of the test are illustrated in Fig. 5. The total stoppage time was approximately 6% of the total infield time. Most of the stoppage occurred in the travels from A to B. In this travel the tractor was carried to the right, because of the slope of the ground and the offset load of the plow. Counter steering was difficult because the hydraulic drive levers were hard to manipulate properly and the uneven draft of the plow. The tractor had to be stopped frequently to be reoriented in the field.

Comparing this to plowing from C to D, the tractor was pulled to the left. Since this was countered by the offset load of the plow, counter steering was scarcely needed in this case. As we can see from Fig. 5 the time in making one run from C to D was less than the run from A to B, even though there was an uphill grade when plowing from C to D. Cautious counter steering increased the time required to make one run.

The working rate was 49a/hr, and the field efficiency was 55%. These values are not outstanding, but if we take into account the field conditions, they are quite respectful. In this case we consider this tractor to have out performed a 4-wheel drive tractor.

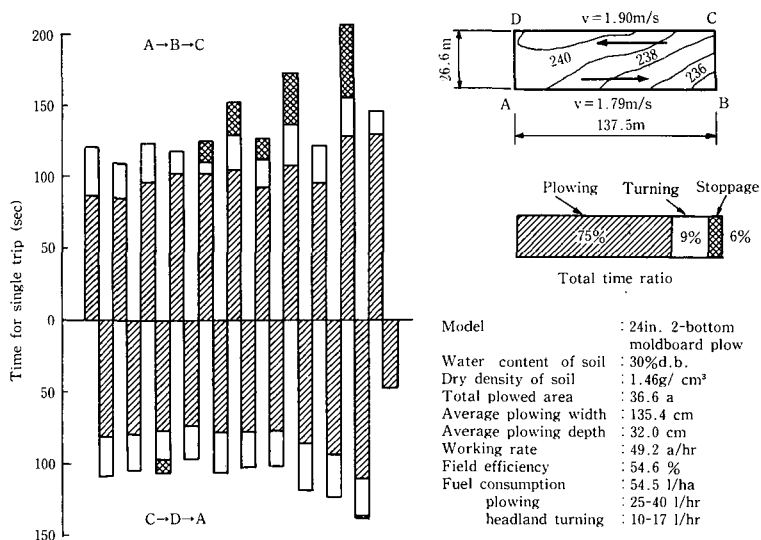

Fig. 5 Results of plowing test.

If improvements are made to the hydraulic controls, by separating steering control from speed control, even in the conditions outlined above, working rates of 60a/hr and a field efficiency of 75%, which can be realized by wheeled tractors in ordinary conditions⁵⁾, could be realized.

2) Rotary Tiller

Tests were conducted in the stubble field. The soil conditions were the same as in plowing test. A Morooka rotary tiller HR2500 with 238cm of working width and 18cm of standard tilling depth was used. Fourteen flanges were welded on the rotor shaft and six blades were bolted on each flange. The rated rotating speed of the rotor shaft was 170rpm at 540rpm PTO speed.

The results of the test are outlined in Fig.6. Traveling speed was 1.53m/s with a tilling pitch of 3cm. The working rate was 33a/hr with a field efficiency of 71%. These low rates are due mostly to inexperience of the operator in working test and the cautious attitude when turning the tractor in the head land. Depth of 23cm could be realized, because of the 184kW of power that produced by the tractor.

Steering controls were not a factor in this test. Fig.7 shows the magnitude of control manipulations in the plowing and rotary tilling. It is evident that during the plowing operation the controls had to be manipulated more often than the rotary tilling operation. During the rotary tilling operation the tractor was not pulled to the left or right as it was in the plowing tests, because the hydraulic power was consumed only by self-propelling and no offset load existed. Thus

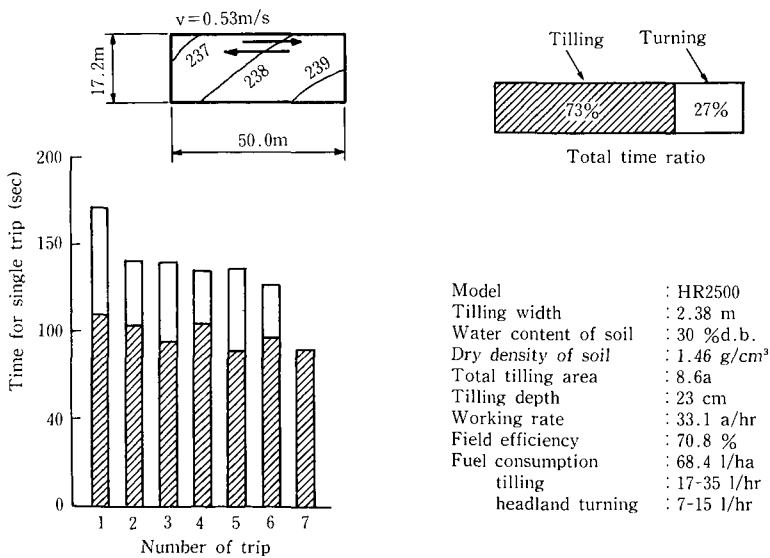

Fig. 6 Results of working test of rotary tiller.

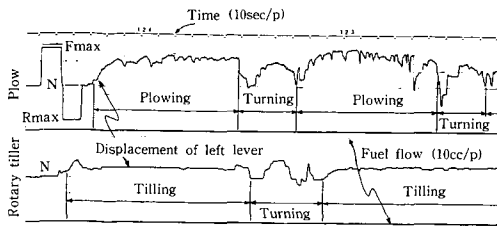

Fig.7 Aspect of manipulation of hydraulic drive lever.

the levers were left in the static position.

3) Subsoiler

The working tests of the subsoiler were carried out in the permanent grassland. The water content of the tested field was 20% d.b., and the dry density of the soil was 1.8g/cm³. The subsoiler was originally equipped with three shanks. Due to the compactness

of the soil, one shank was removed, reducing the working width from 2100mm to 1400mm. The test was carried out with working depth of 37cm.

Results obtained are illustrated in Fig.8. A high working rate of 61.3a/hr was obtained with traveling speed of 1.84m/s. We feel that this working rate could be obtained with working depth of 50cm in ordinary soil conditions.

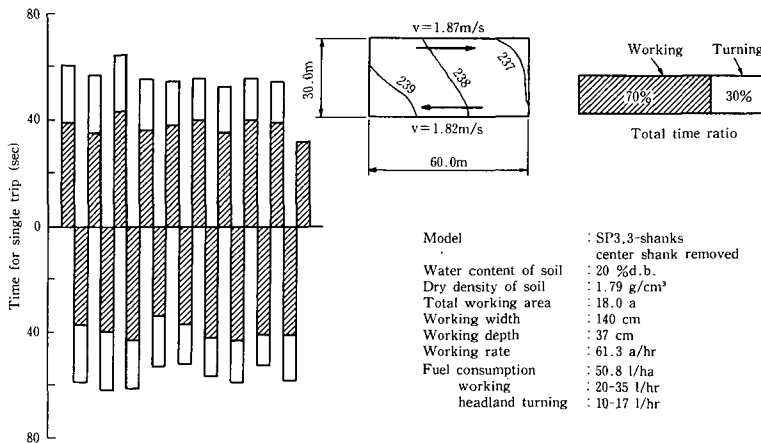

Fig.8 Results of working test of subsoiler.

4) Fuel Consumption

Fig.9 shows the fuel consumption during the plowing and subsoiler tests. As described in the drawbar test, the efficiency of hydraulic system becomes higher as the displacement ratio of pump is increased. Fig.9 also shows the effects of varying engine speed. In the case of plowing, we varied the engine speed and maintained the same traveling speed. In the case of using the slower engine speed (2300rpm), the displacement ratio of pump were set to be greater than in the case of using faster engine speed (2700rpm), thus increasing the efficiency of the hydraulic system.

The fuel consumptions during plowing practice were 20-40 liters/hr at 2300rpm and 25-45 liters/hr at 2700rpm. The estimated iso-power lines ascend

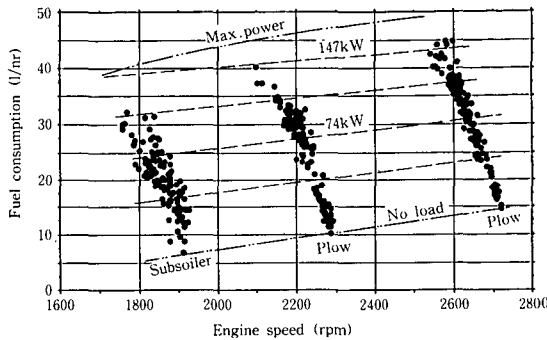

Fig. 9 Fuel consumption of MCT250 during working tests.

gently as the engine speed increases. Therefore, for both engine speeds, the power requirement for plowing was in a same range of 75-100kw. These findings substantiate the fact that greater displacement ratio and lower engine speeds improve the hydraulic efficiency, thus improving overall energy efficiency of this tractor.

Conclusion

The Morooka model MCT250 was used to evaluate the effectiveness of a hydro-static driven rubber-tracked tractor in drawbar test and three agricultural applications, plowing, rotary tilling and subsoiling. In this study the tests were conducted in less than ideal soil conditions. We feel that some of our tests results may not be representative of the true effectiveness of this type of tractor. However, we can see this tractor would perform in real working conditions.

In conclusion, a hydro-static driven rubber-tracked tractor can generate a good dynamic traction, combined with good mobility and ultra-low ground pressure. The rubber tracked tractor could replace the ultra-large wheeled tractors in some agricultural applications. We recommended the following to improve the effectiveness of this tractor;

- 1) Improvement of the hydraulic drive efficiency, such as a addition of mechanical transmissions.
- 2) Separation of speed and steering controls. This would help in situations of heavy tractive operations.
- 3) The installation of a ground speed meter, this will reduce the uncertainty of the hydraulic driven track speeds.
- 4) Completion of hydraulic controls of three point hitch. At the very least, a position control is needed.
- 5) Reduction in the amount of engine noise.

Acknowledgment

We wish to express our deep indebtedness to Dr. Nobuhito MURAI, managing director of Hokkaido Agricultural Machinery Association, for his cooperation

and suggestion throughout this study.

We would like to extend our appreciation to Morooka Co., Ltd. and Sugano Farm Machinery Mfg. CO., Ltd. for their offers of tested machines and test fields, and their cooperation in the tests.

Literature Cited

1. TAYLOR, J.H. and BURT, E.E. : Track and Tire Performance in Agricultural Soils, *Trans. of ASAE*, **18**(1) : 3-6. 1975
2. BASHFORD, L.L., JONES, A.J. and MIELKE, L.N. : Comparison of Bulk Density Beneath a Belt Track and Tire, *Applied. Eng. in Agr.*, **4**(2) : 122-125. 1988
3. HARA, Y : On performance Test of 100PS Class Tractors (Part 2), *J. of JSAM Hokkaido Sect. Japan*, **21** : 26-33. 1980
4. Center for Agr. Equip. Dept. of Agr. Eng. Univ. Nebraska : Caterpillar Challenger 65 Rubber tracked Tractor, Nebraska Tractor Test Report 1613, 1988
5. HUNT, D. : Farm Power and Machinery Management, Iowa State Univ. Press, 5p. 1983