



# HOKKAIDO UNIVERSITY

Title	Cloning and functional characterization of a novel up-regulator, cartregulin, of carnitine transporter, OCTN2
Author(s)	Nagai, Kazuhiko; Takikawa, Osamu; Kawakami, Naoko et al.
Citation	Archives of Biochemistry and Biophysics, 452(1), 29-37 <a href="https://doi.org/10.1016/j.abb.2006.06.006">https://doi.org/10.1016/j.abb.2006.06.006</a>
Issue Date	2006-08-01
Doc URL	<a href="https://hdl.handle.net/2115/14620">https://hdl.handle.net/2115/14620</a>
Type	journal article
File Information	ABB2006-452-1.pdf



**CLONING AND FUNCTIONAL CHARACTERIZATION OF A NOVEL  
UP-REGULATOR, CARTREGULIN, OF CARNITINE TRANSPORTER,  
OCTN2\***

Kazuhiko Nagai<sup>1,2</sup>, Osamu Takikawa<sup>1</sup>, Naoko Kawakami<sup>3</sup>, Mitsuhiro Fukao<sup>1</sup>, Takamitsu Soma<sup>2</sup>, Atsushi Oda<sup>4</sup>, Tadashi Nishiyama<sup>1</sup>, Misato Hayashi<sup>1</sup>, Lingyun Lu<sup>1</sup>, Manabu Nakano<sup>1</sup>, Emi Kajita<sup>1</sup>, Hiroyoshi Fujita<sup>4</sup>, and Soichi Miwa<sup>1#</sup>

Departments of Pharmacology<sup>1</sup>, Cardiovascular Medicine<sup>2</sup> and Environmental Biology<sup>4</sup>, Hokkaido University Graduate School of Medicine, N15, W7, Sapporo 060-8638, Japan. Department of Pharmacology<sup>3</sup>, Kyoto University Graduate School of Medicine, Yoshida Konoe-cho, Sakyo-ku, Kyoto 606-8501, Japan.

Short title: A novel up-regulator of OCTN2

<sup>#</sup>To whom correspondence should be addressed: E-mail: smiwa@med.hokudai.ac.jp;  
Phone: +81-11-706-6921; Fax: +81-11-706-7824.

The subject area of this article is "Cell Biochemistry."

FOOTNOTES:

\*This work was supported by Grants-in-Aid and Special Coordination Funds for Promoting Science and Technology, from the Ministry of Education, Culture, Sports, Science and Technology of Japan, and by a grant from the Smoking Research Foundation, Japan.

The abbreviations used are: OCTN, novel organic cation transporter; RT-PCR, reverse transcription-polymerase chain reaction; PGS, protein G-Sepharose; GST, glutathione S-transferase; ER, endoplasmic reticulum; PBS, phosphate-buffered saline; RT, room temperature; GFP, green fluorescent protein; ET<sub>A</sub>R, endothelin type A receptor; Ab, antibody. The accession number of rat cartregulin cDNA in the GenBank database is ***DQ119106***.

## ABSTRACT

Acetylcarnitine exerts therapeutic effects on some neurological disorders including Alzheimer's disease. OCTN2 is known as a transporter for acetylcarnitine, but its expression in the brain is very low. To examine a brain-specific transporter for acetylcarnitine, we screened a rat brain cDNA library by hybridization using a DNA probe conserved among an OCTN family. A cDNA homologous to OCTN2 cDNA was isolated. The cDNA encoded a novel 146-amino acid protein with one putative transmembrane domain. The mRNA was expressed not only in rat brain but also in some other tissues. The novel protein was localized in endoplasmic reticulum when expressed in COS-7 cells but exhibited no transport activity for acetylcarnitine. However, when co-expressed with OCTN2, it enhanced the OCTN2-mediated transport by about twofold. The enhancement was accompanied by an increase in the levels of mRNA and protein. When OCTN2 was expressed in *Xenopus* oocytes by injection of its cRNA, its transport activity was enhanced by co-expression of the novel protein. These data suggest that the novel protein increases OCTN2 by stabilizing the mRNA in endoplasmic reticulum. The protein may be an up-regulator of OCTN2 and is tentatively designated cartregulin.

**Key words:** cDNA cloning, acetylcarnitine, carnitine, OCTN2, mRNA stabilization, transporter, up-regulation, Alzheimer's disease.

## INTRODUCTION

Carnitine ( $\beta$ -hydroxy- $\gamma$ -trimethylamino butyrate) is essential for the transfer of long chain fatty acids from cytosol to mitochondrial matrix for subsequent  $\beta$ -oxidation to produce cellular energy [1]. Its deficiency therefore impairs the ability to use the fatty acids as fuel, causing critical symptoms such as cardiomyopathy, skeletal muscle myopathy, and hypoglycemia [2]. Carnitine is also the precursor of acetylcarnitine, which is the major constituent of blood acylcarnitine [3]. A study using positron emission tomography has demonstrated that the blood acetylcarnitine is taken up into specific regions of the human brain [4] and the uptake in some of the regions is impaired in the brain of patients with chronic fatigue syndrome [5]. It has recently been reported in mice that the acetyl group of acetylcarnitine is used mainly for synthesis of neurotransmitters such as glutamate and aspartate in the brain [5]. Thus acetylcarnitine appears to play a role in the brain which is distinct from carnitine: this notion is consistent with the observations that acetylcarnitine but not carnitine possesses therapeutic potentials in the treatment of a wide variety of neurological disorders including chronic fatigue syndrome [27], age-dependent memory loss [6, 7] and Alzheimer-type dementia [8, 9]. These data strongly indicate that a transporter for acetylcarnitine is present in the brain and plays an important role for brain function.

In many tissues of human [10, 11], mouse [12, 13], and rat [13], carnitine is transported into cells by a plasma membrane organic cation transporter, OCTN2, in a  $\text{Na}^+$ -dependent manner with a high

affinity for carnitine ( $K_m < 10 \mu\text{M}$ ). Rat OCTN2 is able to transport acetylcarnitine in addition to carnitine [13] and it is therefore likely that both human and mouse OCTN2 can also transport acetylcarnitine. However, levels of mRNA and protein for OCTN2 in the brain of humans or mice are very low or negligible [11, 12]. On the other hand, OCTN1 has been identified as a homologue to OCTN2 in various tissues of the above three mammals [12, 14, 15]. Mouse OCTN1 transports carnitine in a  $\text{Na}^+$ -dependent manner with a low affinity for the substrate ( $K_m > 400 \mu\text{M}$ ) [14], whereas human and rat OCTN1 appear to be inactive for carnitine transport [12, 15]. The transport activity of OCTN1 for acetylcarnitine has not been reported so far, but the activity is expected to be very low or absent based on transport activity for carnitine. In addition to OCTN1 and OCTN2, a third carnitine transporter, OCTN3, has been identified in the mouse [12]. Unlike OCTN2, mouse OCTN3 transports carnitine in a  $\text{Na}^+$ -independent manner and the exclusive expression of OCTN3 in the kidney and testis limits its physiological function in the other tissues [12]. While the corresponding human and rat OCTN3 cDNAs have not yet been isolated, an expression of an OCTN3-like protein has recently been demonstrated in the human sperm and a human cell line by Western blot [16, 17], and a rat OCTN3-like cDNA (NCBI Accession No. *XM\_220427*) is predicted by a computer analysis of a locus of rat chromosome 10 (10q22). It is unknown that mouse OCTN3 or the human OCTN3-like protein can transport acetylcarnitine as well as carnitine. Thus there are at present no definitive candidate molecules for acetylcarnitine transporter in the brain.

Brain region-specific uptake of acetylcarnitine [4], its involvement in the synthesis of neurotransmitters and its therapeutic potentials in neurological disorders encouraged us to speculate that a brain-specific acetylcarnitine transporter or a brain-specific regulator of acetylcarnitine transport is present to tightly regulate the uptake of acetylcarnitine in the brain. To get insights into molecular basis for acetylcarnitine transport into the brain, we attempted to isolate a brain-specific acetylcarnitine transporter. For this purpose, we screened a rat brain cDNA library by a plaque-hybridization method: for a probe, a DNA sequence was used which was conserved between OCTN1 and OCTN2. During the course of this study, we have isolated a new cDNA highly homologous to those of rat OCTNs. Therefore, the new clone appears to be a member of OCTN family. The new cDNA encodes a novel protein consisting of 146 amino acids with one transmembrane domain conserved between rat OCTN1 and OCTN2. The novel protein itself showed no transport activity for carnitine or acetylcarnitine when expressed in COS-7 cells, but it enhanced the transport activity of OCTN2 when co-expressed with OCTN2. The protein thus may be an up-regulator of OCTN2 and is tentatively designated cartregulin. We describe here the cDNA structure, the tissue distribution of its mRNA, the subcellular localization of cartregulin, and some of insights into the mechanism of enhancement of OCTN2 activity caused by the new protein.

## MATERIALS AND METHODS

**Materials** - L-[methyl-<sup>3</sup>H] Carnitine HCl (81 Ci/mmol), PGS, GSH-Sepharose, ECL Plus kit, and pGEX-5X-1 were obtained from Amersham Biosciences. [1-<sup>14</sup>C] Acetyl-L-carnitine (30 Ci/mol) was synthesized as described [5]. COS-7 and CHO cells were cultured in Dulbecco's modified Eagle's medium containing 10% fetal calf serum, penicillin (100 U/ml), and streptomycin (100 µg/ml) at 37 °C under 5% CO<sub>2</sub>. Total RNA and poly (A)<sup>+</sup> RNA from adult male Sprague-Dawley rat tissues or cells were prepared with Sepasol-RNA I (Nacalai Tesque, Kyoto, Japan) and GenElute mRNA Miniprep kits (Sigma), respectively.

**Cloning of cartregulin cDNA** - An oligo(dT)-primed λZAP Express (Stratagene) cDNA library was generated from rat brain poly(A)<sup>+</sup> RNA. About 2 x 10<sup>6</sup> primary cDNAs were plaque-amplified by infection into *E.coli* XL1-Blue MRF' and transferred to Colony/Plaque Screen filters (MEN Life Science Products). The plaques were then screened with a <sup>32</sup>P-labeled 0.35 kb fragment (25-375) of rat OCTN2 cDNA (*AF110416*). Hybridizations were carried out for 16 h at 55 °C in 5x SSC, 5x Denhardt's solution, 0.1% SDS, 30% formamide, 50 mM Na-phosphate buffer (pH 6.5), and 100 µg/ml denatured salmon sperm DNA. The filters were then washed three times with 0.5x SSC, 0.1% SDS for 30 min at 50 °C. Positive clones were plaque-purified and excised into pBK-CMV phagemids by infection with ExAssist helper phage (Stratagene).

**Northern blot and RT-PCR for cartregulin** - Twenty µg of poly(A)<sup>+</sup> RNA mRNA from various rat

tissues, electrophoresed in a 1% agarose gel and transferred onto a nitrocellulose membrane, was hybridized with a <sup>32</sup>P-labeled 0.195 kb cartregulin cDNA fragment (18-212) for 16 h at 42 °C in 20 mM Na phosphate buffer (pH 7.0), 50% formamide, 5x SSC, 5x Denhart's solution, 0.1% SDS, 100 µg/ml denatured salmon sperm DNA, and 10% dextran sulfate. The membrane was then washed with 2x SSC containing 0.1% SDS at RT for 30 min and finally with 0.1x SSC containing 0.1% SDS at 65 °C for 1 h. The radioactivity was measured with a BAS 5000 phosphor-imager (Fuji Photo Film Co. Ltd., Tokyo, Japan). For RT-PCR analysis, 1 µg of poly(A)<sup>+</sup> RNA from various rat tissues was converted to cDNA with a SuperScript II reverse transcriptase (InVitrogen) and oligo dT primers. PCR was carried out for 35 cycles (94 °C for 15 sec, 55 °C for 30 sec, and 72 °C for 45 sec) with forward primer 5'-CCTCACGCCCTGGGTGTCTTTG and reverse primer 5'-CCCGCTGGGAATCTGAAGAC. The 0.195 kb product was separated in 2% agarose gel and stained with ethidium bromide.

**Western blot** - COS-7 cells (3 x 10<sup>6</sup> cells) were transfected with 10.8 µg of pBK-CMV carrying appropriate cDNA with 67.5 µl of Polyfect (QIAGEN). At indicated times after transfection (Figs. 3, 7), the cells were washed twice with ice-cold PBS and solubilized with the lysis buffer [25 mM Tris-HCl buffer (pH8.0), 50 mM NaCl, 1% Triton X-100, 1x Complete protease inhibitor cocktail (Roche Diagnosis)]. As for cartregulin, the cells were solubilized with NE-PER Nuclear and Cytoplasmic Extraction Reagents (PIERCE). The lysate was pretreated with 90 µl of 50% PGS for 1

h and then mixed with 1  $\mu$ g of rabbit primary Ab against each protein. The Ab to cartregulin was prepared in this study (see below). The anti-rat OCTN2 and OCTN1 Abs were donated by Dr. Nezu [12] and the anti-ET<sub>A</sub>R was a gift of Dr. Nakajima. After incubation with the primary Ab for 1 h, 60  $\mu$ l of 50% PGS was added to the mixture and incubated for 1 h at 37°C to form antigen-Ab-PGS complex. The tertiary complex was washed twice with the wash buffer [10 mM Tris-HCl (pH 7.8), 0.15 M NaCl, 1 mM EDTA, 0.1% Tween 20] and the antigen was released from the complex by heating at 95 °C for 5 min with 120  $\mu$ l of SDS-PAGE sample buffer [29], separated by 12 or 15 % SDS-PAGE, and transferred onto nitrocellulose membrane. The membrane was then blocked for 1 h at RT with 2% BSA in TBST [50 mM Tris-HCl (pH 7.8), 0.1 M NaCl, and 0.05% Tween 20] and incubated for 1 h at RT with the primary Ab, and subsequently with the goat anti-rabbit IgG conjugated to horseradish-peroxidase labeled EnVision<sup>+</sup> polymer (DAKO) as described [18]. The antigen was visualized using BIOMAX film (Kodak) with ECL Plus kit and analyzed with a MCID densitometer (Imaging Research Inc. Canada). The Ab to cartregulin was isolated from the rabbit anti-serum raised to its C-terminus peptide (QKFFPSQFELYSP) fused with GST using GSH-Sepharose column. The GST-fusion protein was produced in BL-21 gold E.coli (Stratagene) transformed with pGEX-5X-1 carrying the coding region of cartregulin cDNA.

***Northern blot of OCTN2, OCTN1, and ET<sub>A</sub>R*** – Twenty  $\mu$ g of total RNA prepared from COS-7 cells ( $3 \times 10^6$  cells) transfected with pBK-CMV carrying cDNA for rat OCTN2 [13], rat OCTN1 [15], or

human ET<sub>A</sub>R [28] along with or without pBK-CMV carrying cartregulin cDNA, was subjected to Northern blot analysis under the same conditions used for cartregulin mRNA. As probes, a 0.25 kb fragment (494-752) of rat OCTN2 cDNA, a 0.5 kb fragment (1463-1950) of rat OCTN1 cDNA, or the full size (1.6 kb) of the ETR<sub>A</sub> cDNA was used.

***Immunofluorescence experiments*** - Cells on glass coverslips were washed with ice-cold PBS and fixed with 3.7% paraformaldehyde for 30 min at RT. The cells were then permeabilized in 0.15% Triton X-100 in PBS for 5 min, rinsed with PBS, and blocked with Block Ace (Snow Brand, Tokyo) for 30 min at RT. Mouse anti-ER (KDEL) Ab (Stressgen; Victoria, Canada) at 3 µg/ml in PBS with 10% of Block Ace was added for 10 min at RT. After washing with PBS, the cells were incubated for 10 min at RT with Alexia Fluor 546-conjugated secondary Ab (Molecular Probes, Eugene, OR) at 3 µg/ml in PBS with 10% of Block Ace. The fluorescent images were taken with a Zeiss LSM 510 confocal microscope. To add GFP to the C-terminal end of cartregulin, the coding region of cartregulin cDNA was subcloned into pEGFP-N1 vector (BD Biosciences) at SacI/SacII site.

***Transport study in COS-7 cells*** – COS-7 cells (10<sup>5</sup> cells/well) cultured in a 24-well plat were transfected with 0.3 µg of vector with 2 µl of Polyfect. After culture for 48h, the cells were washed twice with 1 ml of transport buffer (TB) [125 mM NaCl, 4.8 mM KCl, 5.6 mM D-glucose, 1.2 mM CaCl<sub>2</sub>, 1.2 mM KH<sub>2</sub>PO<sub>4</sub>, 1.2 mM MgSO<sub>4</sub>, and 25 mM HEPES (pH 7.4)]. Then cells were pre-incubated in 0.2 ml of TB for 10 min at 37 °C, and transport reaction was initiated by the addition

of 0.2 ml of TB containing 20 nM [<sup>3</sup>H]-carnitine or 1.0 μM [<sup>14</sup>C]-acetylcarnitine. After 1h, the reaction was terminated by aspiration of TB followed by two washes with 1 ml of ice-cold TB. The amounts of [<sup>3</sup>H]-carnitine or [<sup>14</sup>C]-acetylcarnitine transported into the cells were counted with a liquid-scintillation counter as described [11].

***Transport study in Xenopus oocytes*** – Freshly collected oocytes were washed in Ca<sup>2+</sup>-free MBS (88 mM NaCl, 1 mM KCl, 2.4 mM NaHCO<sub>3</sub>, 0.82 mM MgSO<sub>4</sub>, 0.3 mM Ca(NO<sub>3</sub>)<sub>2</sub>, 0.41 mM CaCl<sub>2</sub>, 15 mM Tris-HCl, pH 7.4). After defolliculation for 3h at 20 °C in Ca<sup>2+</sup>-free MBS containing 2 mg/ml of collagenase A (Roche Diagnosis), oocytes were incubated in MBS overnight at 20 °C and injected with 50 nl of cRNA dissolved in water. After 48h incubation in MBS, oocytes were washed with ND 96 medium (96 mM NaCl, 2 mM KCl, 2 mM CaCl<sub>2</sub>, 1 mM MgCl<sub>2</sub>, 5 mM HEPES, pH 7.4) and incubated with ND 96 medium containing 1.0 μM [<sup>14</sup>C]-acetylcarnitine for 20 min at 25 °C. Oocytes were then washed five times with 5 ml of ND 96 and the amounts of [<sup>14</sup>C]-acetylcarnitine transported into the cells were counted as described above. cRNA was synthesized using AmpliScribe T7 transcription kits (EPICENTRE, Madison, WI) and purified with RNeasy kits (QIAGEN).

## RESULTS

### *Cloning of cartregulinc DNA.*

We have screened a rat brain cDNA library (about  $2 \times 10^6$  independent cDNA) with cross-hybridization using a probe from a highly conserved sequence between OCTN1 and OCTN2, and finally obtained 20 positive cDNA clones. Of the 20 cDNA clones, 12 clones encoded OCTN2, 7 clones OCTN1, and the remaining 1 clone a new sequence designated cartregulin.

### *Structure of cartregulin cDNA.*

The cartregulin cDNA that consisted of 2926 nucleotides had a 5'-untranslated region of 233 bp and an open reading frame of 438 bp encoding a polypeptide of 146 amino acids. The coding region was followed by a long 3'-untranslated region of about 2300 bp including a polyadenylation signal (AATAAA) at the end of the sequence (Fig. 1). Homology analysis indicated that the first ~ 0.6 kb sequence (1-626) of cartregulin cDNA was unique because no sequences identical to this part were found in any databases of rat cDNA and genome DNA available at present. However, the part (240-626) of the first 0.6 kb sequence was highly homologous to the corresponding region (78-464) of rat OCTN1 cDNA (*AF169831*) with 85% identity or the region (107-493) of rat OCTN2 cDNA (*AF110416*) with 90% identity. Further homology analysis (Fig. 1) revealed that the middle ~1.5 kb sequence (627-2119) of cartregulin was essentially identical to the sequence of 350-1839 of a putative rat OCTN3 cDNA (*XM\_220427*), which was predicted by a computational analysis of an annotated rat

genomic sequence located in the chromosome 10 (q22) (*NW\_047334*) using gene prediction methods, GNOMON (<http://www.ncbi.nlm.nih.gov/genome/guide/gnomon.html>) and TWINSKAN (<http://genes.cs.wustl.edu/>). The untranslated ~0.8 kb sequence from 2120 to the polyadenylation signal sequence was derived from the sequence of the chromosome 10 located after exon 10.

***Structure of cartregulin protein and its subcellular localization.***

Homology analysis of the 146 amino acid protein encoded by the cartregulin cDNA revealed that the first 131 amino acid of the protein was highly homologous to corresponding parts of rat OCTN1 [15] and OCTN2 [13] with 80% or 85% identity, respectively (Fig. 2). The predicted cartregulin protein had a transmembrane domain (FQRLIFFLLSASII), which was identical to the conserved first domain of 11 or 12 transmembrane domains of rat OCTN1 or OCTN2, respectively. It also had three putative N-glycosylation sites conserved between rat OCTN1 and OCTN2. To clarify the size of cartregulin, we expressed it in COS-7 cells by transfection with the vector carrying cartregulin cDNA and analyzed by Western Blotting with a rabbit Ab raised against to the unique C-terminus amino acid sequence (QKFFPSQFELYSP) of cartregulin. The protein expressed in COS-7 cells gave two bands with sizes of 27 kDa and 23 kDa, which were bigger than the expected size (16 kDa) of unmodified naked protein (Fig. 3). This result suggested that cartregulin was post-translationally modified, such as, glycosylation. To examine the intracellular localization of cartregulin protein, cartregulin tagged with GFP was expressed in CHO or COS-7 cells and its subcellular distribution was

examined with a confocal microscopy. As shown in Fig. 4, the subcellular distribution of the cartregulin protein in CHO cells was almost identical to that of ER, which was identified with anti KDEL Ab. Similar results were obtained for COS-7 cells (data not shown). These findings indicated that the cartregulin protein was localized in ER.

#### ***Tissue distribution of cartregulin mRNA.***

The tissue distribution of cartregulin mRNA was examined by Northern blot analysis and RT-PCR. The probe for Northern blot was a non-coding 195 bp sequence (18-213) of cartregulin cDNA, which was carefully designed to avoid cross-reaction with mRNAs for rat OCTN1, OCTN2 or the putative OCTN3. As shown in Fig. 5A, the ~3.0 kb mRNA corresponding to the cartregulin cDNA in size was detected in many tissues of rat. The mRNA was strongly expressed in the rat kidney and epididymis, moderately in the intestine and colon, and weakly in the brain, lung, heart and skeletal muscle, but it was undetectable in the liver, stomach, and spleen. In the testis, two mRNAs with different sizes (~2.3 kb and ~3.3 kb) were found, suggesting an occurrence of splicing variants of cartregulin mRNA. Essentially similar tissue distribution of cartregulin mRNA was obtained when examined by RT-PCR with a pair of primers that amplify the 195 bp sequence (18-213) specific for cartregulin mRNA (Fig. 5B).

#### ***Functional characterization of cartregulin.***

The high sequence homology of cartregulin to the part of OCTN1 or OCTN2 (Fig. 2) prompted

us to test the possibility that the cartregulin has a transport activity for carnitine and acetylcarnitine. The cartregulin cDNA ligated with a mammalian expression vector (pBK-CMV) driven by a cytomegalovirus promoter was transfected into COS-7 cells and the uptake of carnitine or acetylcarnitine was measured. Under our assay conditions, however, we were unable to demonstrate any transport activity of cartregulin for carnitine or acetylcarnitine, being consistent with the fact that cartregulin is expressed in ER but not in plasma membrane (Fig. 4). Then, we examined the possibility that cartregulin may modulate the transport activity of OCTN2. When cartregulin was co-transfected with OCTN2, it enhanced the transport activity of OCTN2 for carnitine by about 2-fold (Fig. 6). Similarly, cartregulin enhanced the transport activity of OCTN2 for acetylcarnitine by about 2-fold (data not shown). However, the enhancement of the transport activity of OCTN2 for carnitine or acetylcarnitine was not observed following transfection of the mock vector alone (not containing cartregulin cDNA) or the vector carrying rat OCTN1 cDNA, which was inactive for the transport activity for carnitine as reported previously [13].

***The mechanism of the enhancement of OCTN2 transport activity caused by cartregulin.***

To understand how cartregulin enhances the transport activity of OCTN2, we first investigated the kinetic parameters ( $K_m$  and  $V_{max}$  values) of OCTN2 for carnitine or acetylcarnitine as described by Tamai et al. [11]. The  $V_{max}$  represents the maximal transport activity at saturated concentrations of the substrate and the  $K_m$  value (the Michaelis constant) is defined as the concentration of the substrate

which gives the half activity of the  $V_{max}$ . Our results indicated that the  $K_m$  values of  $12.6 \pm 1.3 \mu\text{M}$  and  $17.7 \pm 1.7 \mu\text{M}$  for carnitine and acetylcarnitine, respectively, in cells expressing OCTN2 alone were not significantly changed by cartregulin ( $K_m$  values of  $11.1 \pm 2.0 \mu\text{M}$  and  $18.3 \pm 1.4 \mu\text{M}$  in cells expressing OCTN2 and cartregulin). These  $K_m$  values represent the mean  $\pm$  S.E. from three independent experiments. In contrast, the  $V_{max}$  values expressed as  $\text{pmol/h}/10^6$  cells increased from  $53 \pm 5$  to  $90 \pm 10$  for carnitine and from  $70 \pm 8$  to  $110 \pm 15$  for acetylcarnitine. These results suggested that the increase in the transport activity of OCTN2 was not caused by an increase in its affinity for carnitine or acetylcarnitine but by an increase in the protein level of the transporter. To address this point, we carried out Western blot and analysed the protein level of OCTN2 with an Ab against rat OCTN2. When expressed in COS-7 cells, OCTN2 existed as three forms with different molecular sizes: 60 kDa, ~80 kDa and ~160 kDa (Fig. 7A). The 60 kDa protein was likely to be the unmodified naked form of OCTN2, and the ~80 kDa protein was considered to be a post-translationally modified (e.g., glycosylation) form of OCTN2, and the ~160 kDa entity was probably a dimeric form of the ~80 kDa protein. The levels of the major 80 kDa and 160 kDa forms of OCTN2 (Figs. 7A and 7D) were significantly elevated by co-transfection of cartregulin cDNA in parallel with the enhancement of the transport activity of OCTN2 (Fig. 7C). These findings clearly indicated that the increase in the transport activity of OCTN2 caused by cartregulin was due to an increase in protein levels of OCTN2 in COS-7 cells. To test whether the increase in protein levels of

OCTN2 is caused by an increase in the level of OCTN2 mRNA, we measured the transcript by Northern blot. Following the co-expression of cartregulin, the level of OCTN2 mRNA increased to the same extent as that of OCTN2 protein (Figs. 7B and 7E). These results demonstrated that the enhancement was due to an increase in the level of OCTN2 mRNA.

To determine whether the effect of cartregulin is specific for OCTN2, we examined the effect of cartregulin on levels of protein and mRNA for OCTN1 or ET<sub>A</sub>R, and found that these parameters were unaffected by co-expression of cartregulin (data not shown). These results indicated that the effect of cartregulin is specific for OCTN2.

In general, an elevation of mRNA level is explained by two mechanisms. One mechanism is an increase in the rate of transcription and the other is a stabilization of mRNA, that is, an inhibition of decay of mRNA. The transcription (synthesis of mRNA) of OCTN2 cDNA ligated with the eukaryotic expression vector, pBK-CMV, is under the control of a promoter of a cytomegalovirus and the transcription requires binding of endogenous transcription factors of transfected cells to the promoter sequence of the vector. These events occur in nucleus and therefore the vector should be transferred to nucleus for transcription of the OCTN2 cDNA [26]. Since cartregulin is localized in ER (Fig. 4), it is unable to activate the transcription of OCTN2 by interacting directly with the promoter element or by interacting with the endogenous transcription factors in nucleus. Rather, it is plausible that cartregulin stabilizes OCTN2 mRNA in ER and thereby increases the mRNA levels of

OCTN2, leading to an elevation in protein level of OCTN2. To test this idea, OCTN2 cRNA was injected into *Xenopus* oocytes alone or in combination with cartregulin cRNA and the uptake of acetylcarnitine into the oocytes was measured. As shown in Fig. 8, there was no substantial uptake of acetylcarnitine into the oocytes injected with cartregulin cRNA or OCTN1, as compared with that into oocytes injected with tRNA alone. Notably, the uptake of acetylcarnitine via OCTN2 increased by about two-fold in oocytes injected with OCTN2 cRNA in combination with that for cartregulin, as compared with the uptake in oocytes injected with OCTN2 cRNA alone. Because the amount of injected OCTN2 cRNA is the same among oocytes (50 ng/oocyte), the enhancement of transport activity of OCTN2 is interpreted to reflect an elevation of OCTN2 protein resulting from stabilization of OCTN2 mRNA by cartregulin and a subsequent increase in the mRNA level. However, co-injection of cRNA for OCTN1 into oocytes was without effect on the uptake of acetylcarnitine via OCTN2. Thus, we concluded that cartregulin specifically stabilized OCTN2 mRNA and thereby increased OCTN2 expression.

## DISCUSSION

In this study, we have isolated a new cDNA, cartregulin, from a rat brain cDNA library, which functions as an upregulator of OCTN2, a membrane transporter for carnitine and acetylcarnitine. Homology analysis revealed that the cartregulin cDNA is a member of OCTN family. A significant part of cartregulin cDNA sequence was essentially identical to a part of the putative rat OCTN3 cDNA (*XM\_220427*), which was predicted by computational analysis of an annotated rat genomic sequence (*NW\_047334*), spanning ~73 kb in a locus of the chromosome 10 (10q22) (Fig. 1). Although the predicted OCTN3 cDNA consists of 10 exons, long sequences of ~ 42 kb located between exon 1 and exon 2 and of the ~ 3 kb sequence located between exon 2 and exon 3 have not yet been determined. The predicted rat 1.8 kb OCTN3 cDNA has an open reading frame of 1359 bp and the OCTN3 protein therefore consists of 453 amino acids (~50 kDa). This size is much smaller than those of mouse OCTN3 (564 amino acids and ~ 60 kDa) (12) and human OCTN3 (~ 60 kDa), whose sizes are rather very close to those of other OCTNs such as OCTN1 (553 amino acids) and OCTN2 (557 amino acids) expressed in rodent and human tissues (10-15). The N-terminal amino acid sequence (1-30 amino acids) of the rat putative OCTN3, encoded by the exons 1-3, has no significant homology with those of rat OCTNs, whereas the remaining amino acid sequence (31-423 amino acids), encoded by the exons 4-10, exhibits a high homology (~ 90 %) to that of the corresponding region of mouse OCTN3

[12]. In addition, we failed to amplify the putative cDNA fragment derived from exons 1-3 by PCR using the rat brain cDNA library used here (data not shown). These findings taken together indicated that the rat OCTN3 cDNA was predicted wrongly by the computer-based gene prediction methods, where the exons 1-3 were incorrectly recognized and combined with the exons 4-10 to generate the putative OCTN3 cDNA. Under these circumstances, it is therefore likely that the unique sequence of cartregulin cDNA from 1 to 626 is derived from undiscovered exons located in the gap regions in the locus of rat chromosome 10 (10q22). The “correct” rat homologue of OCTN3 cDNA may consist of some of the undiscovered exons located in the same gap regions and the exons 4-10. In this context, cartregulin may be a splicing variant of the correct OCTN3, because both share the same exons 4-10.

In contrast to the plasma membrane transporters, OCTNs, cartregulin is localized in ER, suggesting a distinct role of cartregulin from those of OCTNs, and in fact cartregulin was found to increase the expression of OCTN2 when co-expressed in cultured cells. This increase is due to an elevation of OCTN2 mRNA through a cartregulin-mediated stabilization of the mRNA. This new finding raises the question of how cartregulin stabilizes OCTN2 mRNA. Based on previous works on mRNA stabilization/destabilization [reviewed in 21, 22], the OCTN2 mRNA might become resistant to ribonucleases by binding of cartregulin to the *cis*-elements of 5'-untranslated region (UTR) or 3'-UTR of OCTN2 mRNA. Several such *cis*-elements have been identified for various mRNAs. For example, the c-jun N-terminal kinase (JNK)-response element in the 5'-UTR plays a role in the

stabilization of mRNAs for interleukin-2 and chemokine KC, and nucleolin and YB-1 are demonstrated to bind to the JNK-response element [23]. As for such elements in the 3'-UTR mRNA, the adenosine-uridine regions (AUUUA) or AU rich element (ARE) is identified for various mRNAs, and ELAV and AUF1 proteins are shown to interact with the ARE [21]. It is also reported that a C-rich element in the 3'-UTR of  $\alpha$ -globin mRNA is critical for the stability of this long-lived mRNA and  $\alpha$ -CP protein is demonstrated to bind to the element [24]. In addition to the 5'-UTR or 3'-UTR of mRNA, a part of the coding region of mRNA has been shown to be implicated in its stability. For example, the exon 3 region of c-myc mRNA is identified to protect the mRNA from nucleases, and a binding of a 70 kDa protein to the element is demonstrated [25]. Sequence analysis of cartregulin, however, indicated that neither of the JNK-element, the ARE-element or the C-rich element is present in the 5'-UTR or 3'-UTR of OCTN2 mRNA. These data suggest that a novel element in either 5'-UTR or 3'-UTR of OCTN2 mRNA is involved in the cartregulin-mediated stabilization of the mRNA. Alternatively, an element of the coding region of OCTN2 mRNA is responsible for the cartregulin-mediated stabilization. It is also possible that cartregulin may be indirectly involved in the stabilization of OCTN2 mRNA, where cartregulin associates with other effector protein that interacts directly with the UTR or the coding element of OCTN2 mRNA. Analysis of the putative element of OCTN2 mRNA is in progress in our laboratory.

The mRNA-stabilizing action of cartregulin is specific for OCTN2 mRNA, because the levels of

protein and mRNA for OCTN1 and ET<sub>A</sub>R were unaffected by cartregulin. Conversely, the stabilization of mRNA for OCTN2 is specific for cartregulin, because OCTN1 (an analog of cartregulin) showed no mRNA-stabilizing action. This specificity may be explained by the hypothesis that the stabilization of OCTN2 mRNA is attained through a specific interaction between cartregulin and an element of OCTN2 mRNA.

Of interest is that the tissue distribution of cartregulin mRNA (Fig. 5) differed from that of OCTN2 [11]; the expression of cartregulin mRNA is undetectable in some organs such as the liver, spleen, and stomach, whereas OCTN2 mRNA is expressed ubiquitously in many organs. The most striking difference is observed in the skeletal muscle, where the expression of cartregulin is very low, being in contrast with the highest expression of OCTN2 among many tissues [11]. This non-parallel expression of cartregulin with OCTN2 indicates that the expression of cartregulin is controlled in a different way from that of OCTN2.

OCTN2 transports carnitine as well as acetylcarnitine. Not only carnitine plays an important role in transfer of long chain fatty acids from cytosol into mitochondria for  $\beta$ -oxidation, but also it has been recently shown that carnitine prevents injury of normal cells caused by a anti-cancer drug, cisplatin [19] and inhibits hepatocarcinogenesis via protection of mitochondria [20]. Acetylcarnitine, on the other hand, has been attracting much attention because of its pharmacological effects on various neurological disorders such as age-dependent memory loss [6, 7], Alzheimer-type dementia [8, 9], and

chronic fatigue syndrome [5]. Therefore, OCTN2 could be a therapeutic target for cancers and neurological diseases, and since cartregulin up-regulates the expression of OCTN2 as shown here, it could be an alternative therapeutic target for these diseases through enhancement of OCTN2 expression.

In conclusion, we were the first to isolate cartregulin cDNA as a new family member of OCTNs, and show a novel role of cartregulin in the regulation of OCTN2. With a better understanding of the regulatory mechanism, we hope to improve the treatment of a variety of diseases with carnitine or acetylcarnitine.

## REFERENCES

- [1] K. Bartlett, S. Eaton, *Eur. J. Biochem.* 271 (2004) 462-469
- [2] Y. Wang, J. Ye, V. Ganapathy, N. Longo, *Proc. Natl. Acad. Sci.* 96 (1999) 2356-2360
- [3] L. Vernez, M. Wenk, S. Krahenbuhl, *Rapid Commun. Mass Spectrom.* 18 (2004) 1233-1238
- [4] H. Kuratsune, Y. Watanabe, K. Yamaguti, G. Jacobsson, M. Takahashi, T. Machii, H. Onoe, K. Onoe, K. Matsumura, S. Valind, T. Kitani, B. Langstrom, *Biochem. Biophys. Res. Commun.* 13 (1997) 488-493
- [5] H. Kuratsune, K. Yamaguti, G. Lindh, B. Evengard, G. Hagberg, K. Matsumura, M. Iwase, H. Onoe, M. Takahashi, T. Machii, Y. Kanakura, T. Kitani, B. Langstrom, Y. Watanabe, *Neuroimage* 17 (2002) 1256-1265
- [6] J. Liu, E. Head, A.M. Gharib, W. Yuan, R.T. Ingersoll, T.M. Hagen, C.W. Cotman, B.N. Ames, *Proc. Natl. Acad. Sci.* 99 (2002) 2356-2361
- [7] T.M. Hagen, J. Liu, J. Lykkesfeldt, C.M. Wehr, R.T. Ingesoll, V. Vinarsky, J.C. Bartholomew, B.N. Ames, *Proc. Natl. Acad. Sci.* 99 (2002) 1870-1875
- [8] L. Parnetti, A. Gaiti, P. Mecocci, D. Cadini, U. Senin, *Eur. J. Clin. Pharmacol.* 42 (1992) 89-93

- [9] J.W. Pettegrew, J. Levine, R.J. McClure, *Mol. Psychiatry* 5 (2000) 616-632
- [10] X. Wu, P.D. Prasad, F.H. Leibach, V. Ganapathy, *Biochem. Biophys. Res. Commun.* 246 (1998) 589-595
- [11] I. Tamai, R. Ohashi, J. Nezu, H. Yabuuchi, A. Oky, M. Shimane, Y. Sai, A. Tsuji, *J. Biol. Chem.* 273 (1998) 20378-20382
- [12] I. Tamai, R. Ohashi, J. Nezu, Y. Sai, D. Kobayashi, A. Oku, M. Shimane, A. Tsuji, *J. Biol. Chem.* 275 (2000) 40064-40072
- [13] X. Wu, W. Huang, P.D. Prasad, P. Seth, D.P. Rajan, F.H. Leibach, J. Chen, S.J. Conway, V. Ganapathy, *J. Pharmacol. Exp. Ther.* 290 (1999) 1482-1492
- [14] I. Tamai, H. Yabuuchi, J. Nezu, Y. Sai, A. Oku, M. Shimane, A. Tsuji, *FEBS Lett.* 419 (1997) 107-111
- [15] X. Wu, R.L. George, W. Huang, H. Wang, S.J. Conway, F.H. Leibach, V. Ganapathy, *Biochim. Biophys. Acta* 1466 (2000) 315-327
- [16] A.M. Lamhonwah, J. Skaug, S.W. Scherer, I. Tein, *Biochem. Biophys. Res. Commun.* 301 (2003) 98-101
- [17] W. Xuan, A.M. Lamhonwah, C. Librach, K. Jarvi., I. Tein, *Biochem. Biophys. Res. Commun.* 306 (2003) 121-128
- [18] T. Fukuda, Y. Tani, T. Kobayashi, Y. Hirayama, O. Hino, *Anal. Biochem.* 285 (2000)

274-276

- [19] B. Chang, M. Nishikawa, E. Sato, K. Utsumi, M. Inoue, *Arch. Biochem. Biophys.* 405 (2002) 55-64
- [20] B. Chang, M. Nishikawa, S. Nishiguchi, M. Inoue, *Int. J. Cancer* 113 (2005) 719-729
- [21] J. Guhaniyogi, G. Brewer, *Gene* 265 (2001) 11-23
- [22] R.E. Dodson, D.J. Shapiro, *Prog. Nucleic Acid Res. Mol. Biol.* 72 (2002) 129-164
- [23] C.Y. Chen, R. Gherzi, J.S. Anderson, G. Gaietta, K. Jurchott, H.D. Royer, M. Mann, M. Karin, *Genes and Dev.* 14 (2000) 1236-1248
- [24] N.D. Dodgers, Z. Wang, M. Kiledjian, *RNA* 8 (2002) 1526-1537
- [25] R.D. Prokipack, D.J. Herrick, J. Ross, *J. Biol. Chem.* 269 (1994) 9261-9269
- [26] J. Sambrook, T. Fritsch, T. Maniatis, *Molecular Cloning: A Laboratory Manual*, 2nd Ed., Cold Spring Harbor Laboratory, Cold Spring Harbor, NY, 1989
- [27] R.C. Vermeulen, H.R. Scholte, *Psychosom. Med.* 66 (2004) 276-282
- [28] K. Hosoda, K. Nakao, A. Hiroshi, S. Suga, Y. Ogawa, M. Mukoyama, G. Shirakami, Y. Saito, S. Nakanishi, H. Imura, *FEBS Lett.* 287 (1991) 23-26
- [29] O. Takikawa, T.K. Littlejohn, R.J.W. Truscott, *Exp. Eye Res.* 72 (2001) 271-277

## **ACKNOWLEDFEMENT**

We are grateful to Dr. Nezu, Chugai Pharmaceuticals, Japan for a kind donation of rabbit anti-mouse OCTN2 and OCTN1 antibodies, and to Dr. Nakajima, Novartis Pharma, Japan for a kind donation of rabbit anti-human ET<sub>A</sub>R Ab.

## FIGURE LEGENDS

**Fig. 1. Structural relationship among cartregulin cDNA, the predicted OCTN3-like cDNA, and the corresponding rat chromosomal gene.**

*Top*, the predicted OCTN3-like cDNA; *Middle*, the corresponding rat chromosome 10 gene (LOC303140); *Bottom*, cartregulin cDNA. The open boxes in the cDNAs indicate open reading frame. The closed boxes in the chromosomal gene represent predicted exons.

**Fig. 2. Amino acid sequence alignment of cartregulin, OCTN1, and OCTN2.**

The closed box indicates a transmembrane domain. Astarisk indicates possible N-glycosylation sites.

**Fig. 3. Western blot analysis of cartregulin expressed in COS7 cells.**

COS-7 cells were transfected with pBK-CMV cartregulin or a mock vector for control. After 48h culture, cell lysates were prepared and expression of cartregulin was analyzed by Western blot with an anti-cartregulin Ab.

**Fig. 4. Localization of cartregulin in ER.**

A (red), CHO cells expressing GFP-tagged cartregulin were fixed and stained with mouse anti-ER (KDEL) Ab followed by Alexia Fluor 546-conjugated anti-mouse IgG. for the detection of ER. B (green), the localization of GFP-cartregulin in the same cells. C, A was merged with B.

**Fig. 5. Northern blot and RT-PCR analyses of cartregulin mRNA.**

A, Twenty  $\mu\text{g}$  of poly(A)<sup>+</sup> mRNA from each rat tissue were Northern blotted. B, RT-PCR of cartregulin mRNA. One  $\mu\text{g}$  of total RNA from each tissue was reverse-transcribed into cDNA and amplified by PCR.

**Fig. 6. Effect of cartregulin on the transport activity of OCTN2 for carnitine in COS-7 cells.**

COS-7 cells ( $1 \times 10^5$  cells) were transfected with 0.3  $\mu\text{g}$  of the indicated combination of pBK-CMV vectors. The mock vector pBK-CMV (0.15  $\mu\text{g}$ ) was added to normalize the total amount of vector added. i) pBK-CMV OCTN2 (0.15  $\mu\text{g}$ ) + pBK-CMV (0.15  $\mu\text{g}$ ); ii) pBK-CMV cartregulin (0.15  $\mu\text{g}$ ) + pBK-CMV (0.15  $\mu\text{g}$ ); iii) pBK-CMV OCTN1 (0.15  $\mu\text{g}$ ) + pBK-CMV (0.15  $\mu\text{g}$ ); iv) pBK-CMV OCTN2 (0.15  $\mu\text{g}$ ) + pBK-CMV cartregulin (0.15  $\mu\text{g}$ ); v) pBK-CMV OCTN2 (0.15  $\mu\text{g}$ ) + pBK-CMV OCTN1 (0.15  $\mu\text{g}$ ). After 48h incubation, uptake

of [<sup>3</sup>H]-carnitine into the cells was determined. The data represent the mean values with standard deviations from three independent experiments.

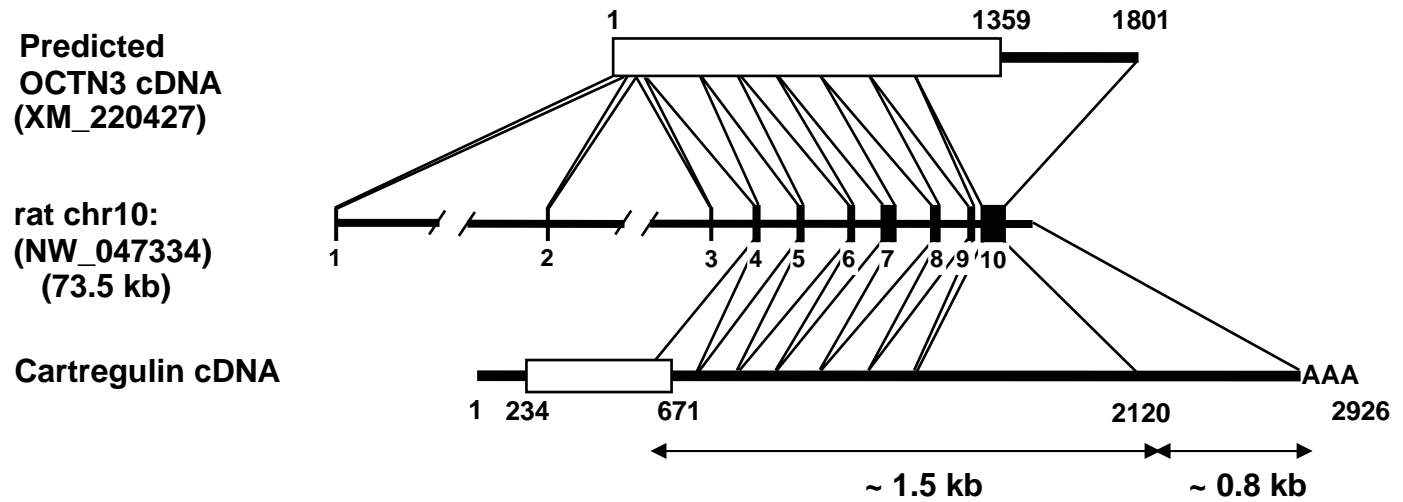
**Fig. 7. Western blot and Northern blot analyses of OCTN2 in COS-7 cells co-expressed with cartregulin.**

COS-7 cells ( $3 \times 10^6$  cells) were transfected with pBK-CMV OCTN2 (5.4  $\mu$ g) and the mock pBK-CMV vector (5.4  $\mu$ g) or co-transfected with pBK-CMV OCTN2 (5.4  $\mu$ g) and pBK-CMV cartregulin (5.4  $\mu$ g). At indicated time after transfection, the expression of OCTN2 was analyzed by Western blot (A) and Northern blot (B). C shows the changes in the transport activity for [<sup>3</sup>H]-carnitine assayed in a 24 well-plate under the same conditions described in the legend of Fig. 6. The data represent the mean values with standard deviations from three independent experiments. D represents densitometric determination of the bands on the Western blot (A). E is the quantitative analysis of the Northern blot (B). The relative density or the relative radioactivity was expressed as percentages of the value at 1 day after transfection with pBK-CMV OCTN2 alone and the mock vector.

**Fig. 8. Effect of cartregulin on the acetylcarnitine transport activity of OCTN2 expressed in *Xenopus* oocytes.**

Xenopus oocytes were injected with 50 nl of following RNA solutions; i) 2 ng/ml of tRNA as control, ii) 1 ng/ml of OCTN2 cRNA and 1 ng/ml of tRNA, iii) 1 ng/ml of OCTN2 cRNA and 1 ng/ml of cartregulin cRNA, iv) 1 ng/ml of OCTN2 cRNA and 1 ng/ml of OCTN1 cRNA, v) 1 ng/ml of cartregulin cRNA and 1 ng/ml of tRNA, vi) cartregulin cRNA and 1 ng/ml of tRNA. After 48h incubation, uptake of [<sup>14</sup>C]-acetylcarnitine into the oocytes was measured. tRNA was added to normalize the total amount of RNA injected. The data represent the mean values with standard deviations from 10 Xenopus oocytes.

# Fig. 1



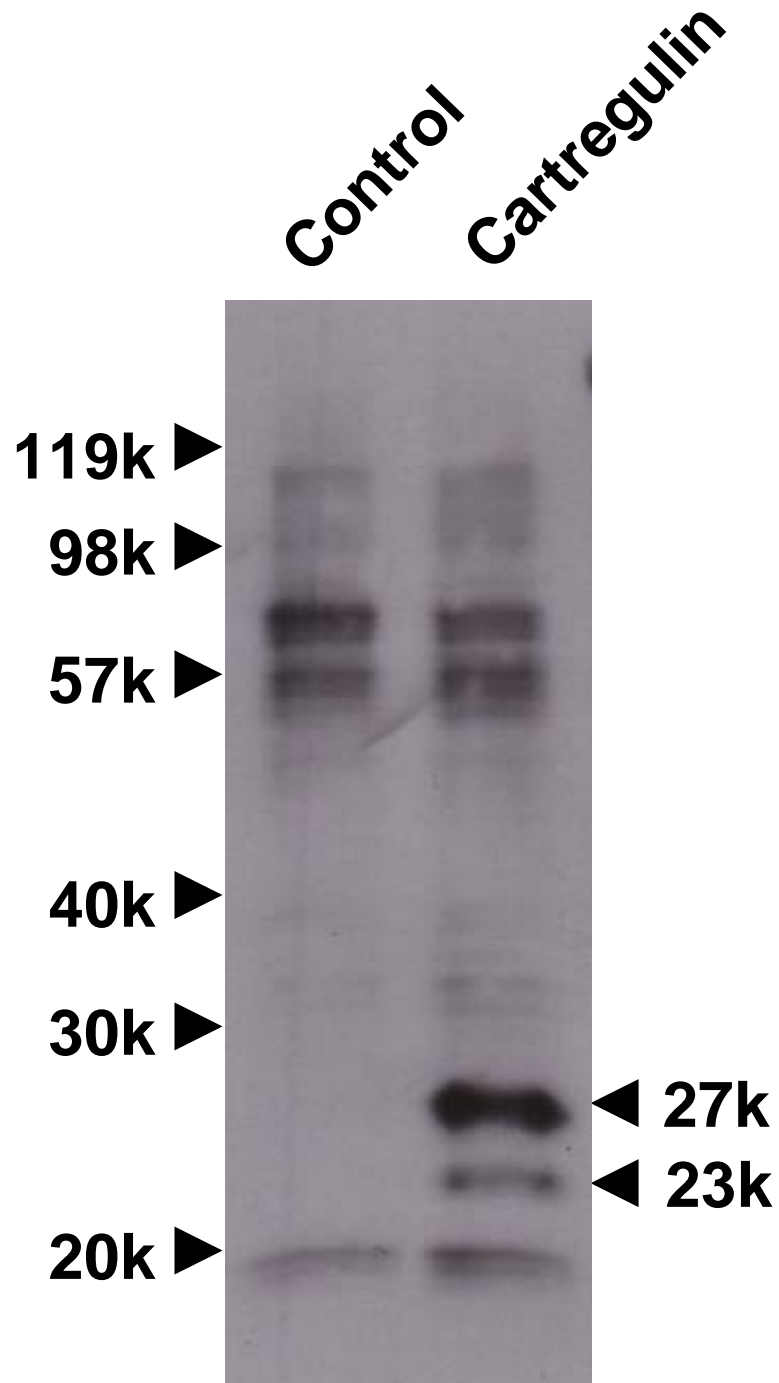
# Fig. 2

	1						*
OCTN2	MRDYDEVIAF	LGDWGPFRQL	IFFLLSASII	PNGFNGMSVV	FLAGTPEHRC	LVPHTVNLSS	
OCTN1	*****T**	**E*****	*****	***N*M*I*	***GT*****	*****	
Cartregulin	*****T**	**E*****	*****	***T*L*A*	***AS*****	***D*****	

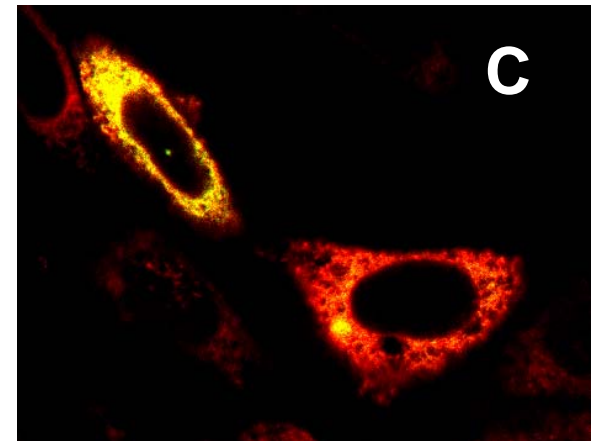
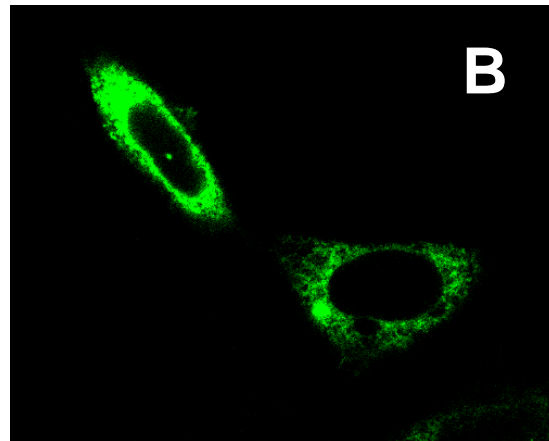
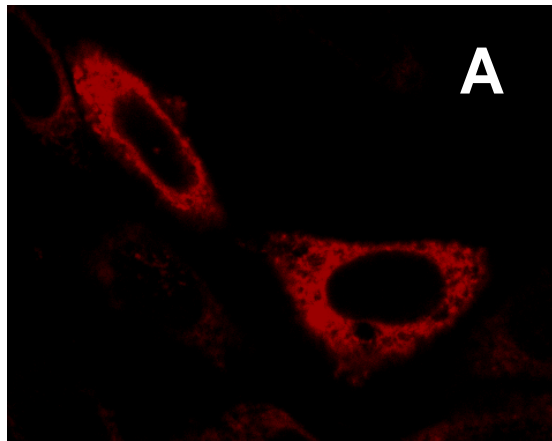
	61	*		*			
OCTN2	AWRNHSIPLE	TKDGRQVPQS	CRRYRLATIA	NFSALGLEPG	LDVDLEQLEQ	ESCLDGWEYS	
OCTN1	*****	*****	*****	*****	R*****	*N*****N	
Cartregulin	*****	M*****HK	*****	*****	E***K***L	*N*****	

	121	131					
OCTN2	KDVFLSTIVT	EWNLVCEDDW	KTPLTTSLEF	VGVLCSFVS	GQL	-----/ /-----	(553)
OCTN1	*****	**D***K***	*****	***M*****	***	-----/ /-----	(557)
Cartregulin	*E*****	*EQKFFPSQF	ELYSPP	(146)			

**Fig. 3**

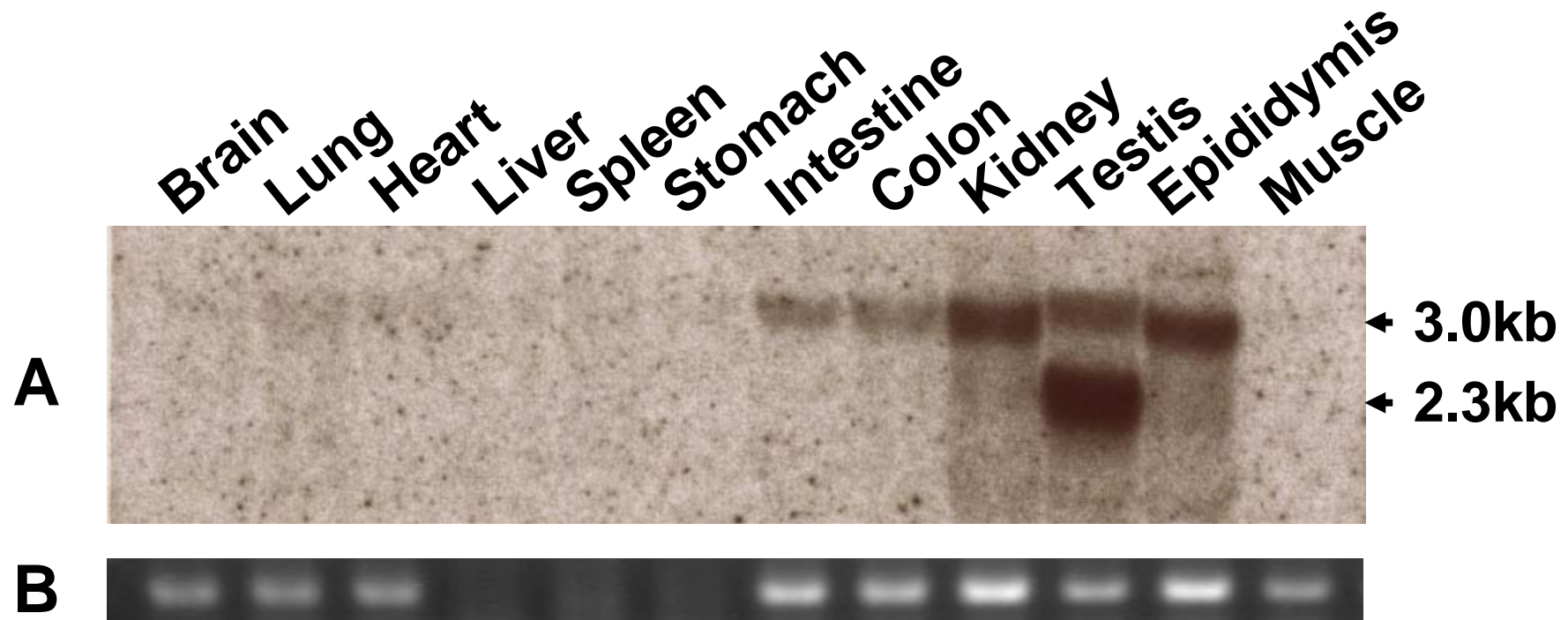


**Fig. 4**



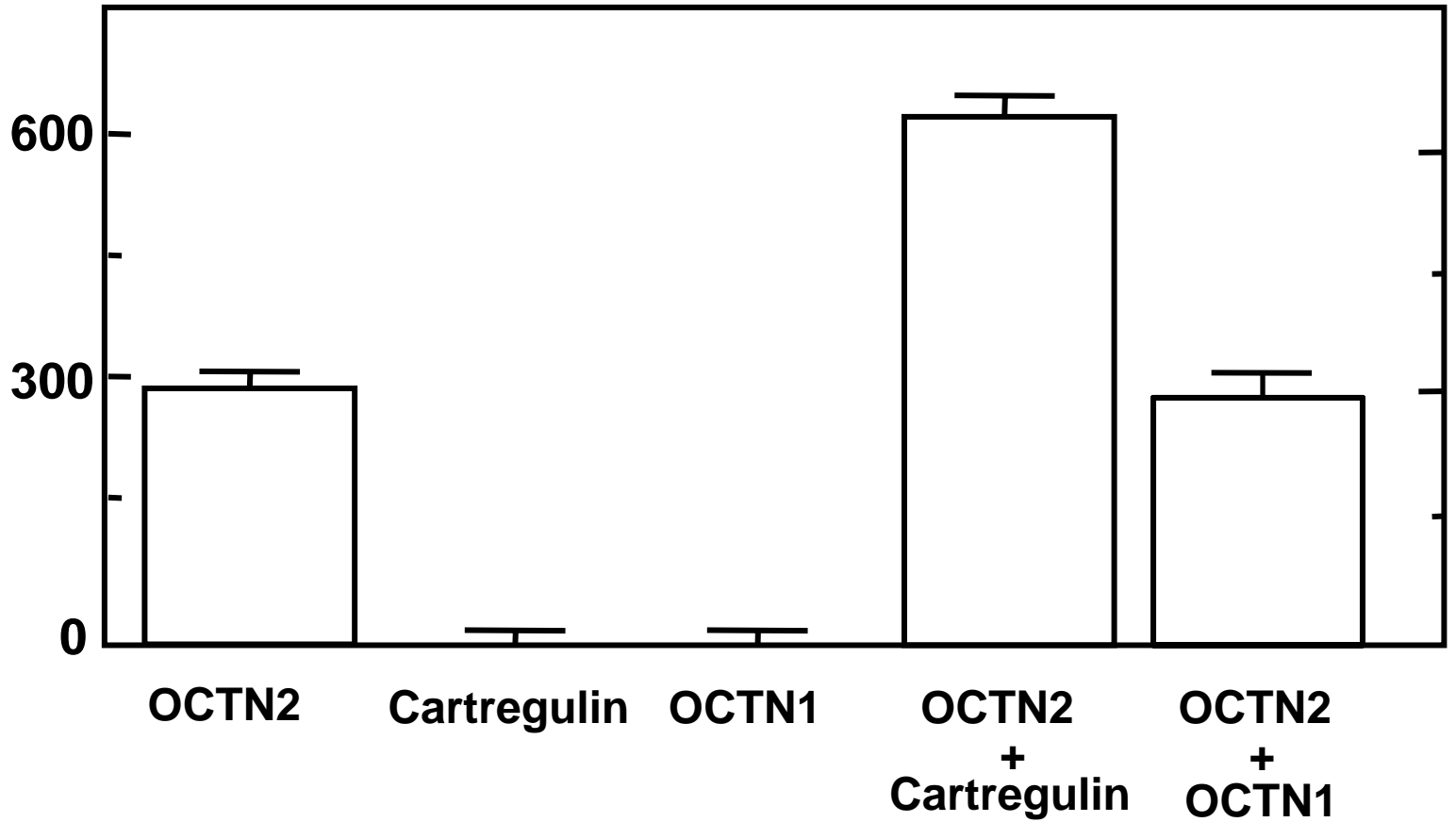
—  
**10  $\mu\text{m}$**

**Fig. 5**

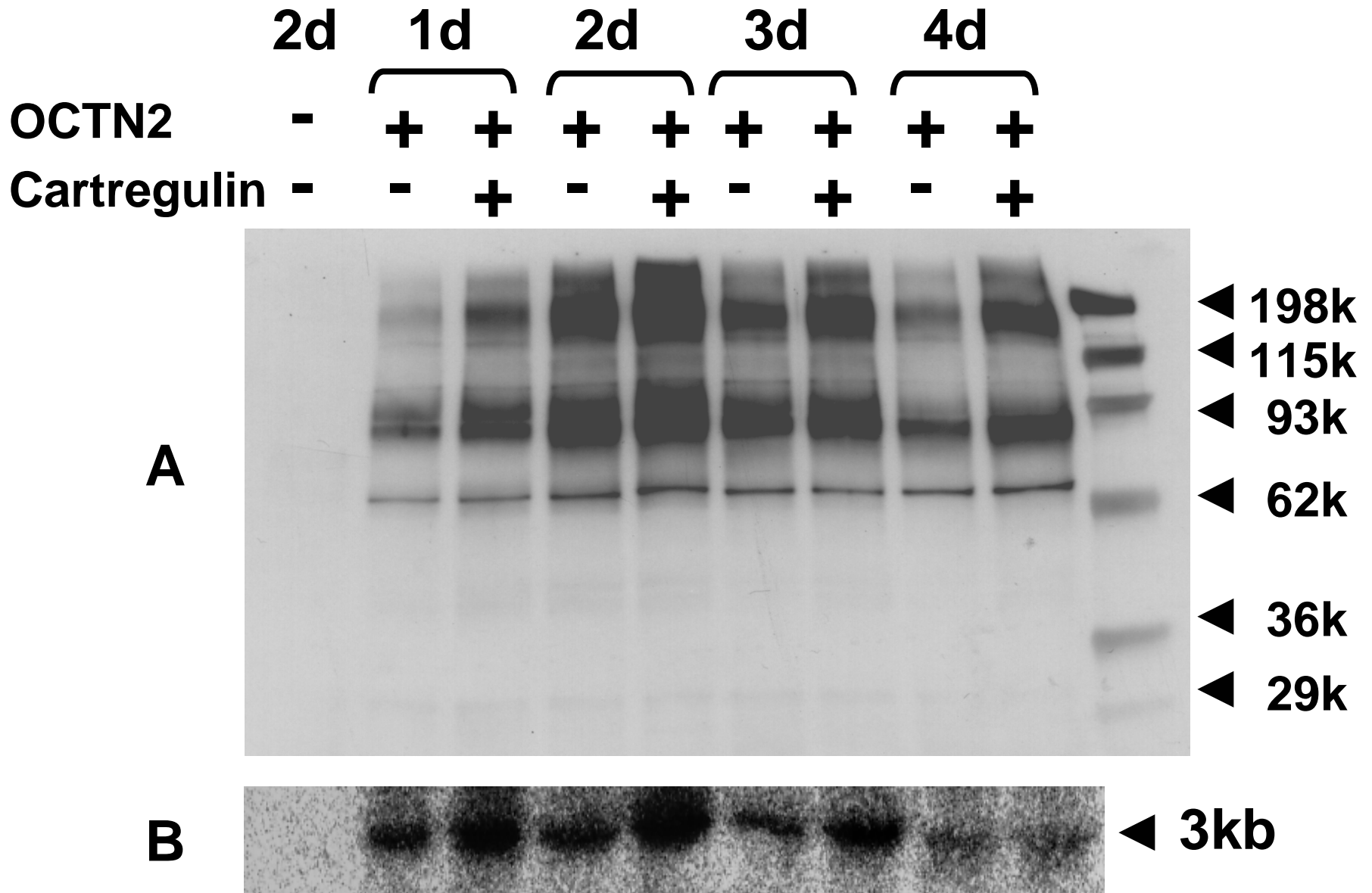


**Fig. 6**

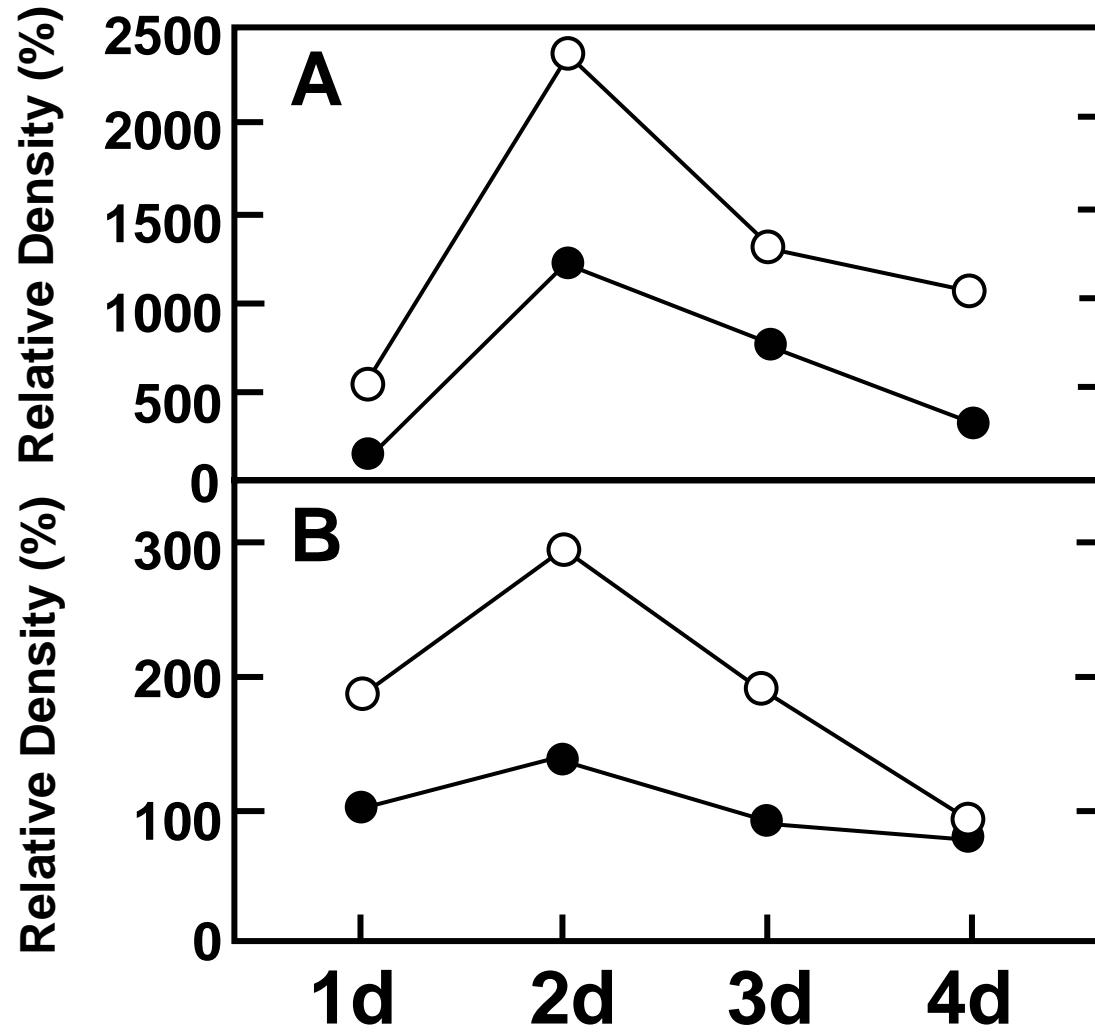
**Uptake of [<sup>3</sup>H]-Carnitine  
(dpm/h/10<sup>6</sup> cells)**



**Fig. 7**



**Fig. 8**



**Fig. 9**

