



# HOKKAIDO UNIVERSITY

|                  |   |
|------------------|---|
| Title            | Preparation and Properties of Immobilized Mercuric Reductase in Porous Glass Carriers |
| Author(s)        | UO, Motohiro; 宇尾, 基弘; NUMATA, Masahiko et al.   |
| Citation         | Journal of Ceramic Society of Japan, 100, 430-433                                     |
| Issue Date       | 1992-04   |
| Doc URL          | <a href="https://hdl.handle.net/2115/17009">https://hdl.handle.net/2115/17009</a>     |
| Type             | journal article   |
| File Information | JCSJ100-430.pdf   |



# Preparation and Properties of Immobilized Mercuric Reductase in Porous Glass Carriers

Motohiro UO, Masahiko NUMATA\*, Masayasu SUZUKI\*\*, Eiichi TAMIYA\*\*,  
Isao KARUBE\*\* and Akio MAKISHIMA

Department of Materials Science, Faculty of Engineering, The University of Tokyo, 7-3-1, Hongo, Bunkyo-ku, Tokyo 113

\*Central Research Laboratory, Dowa Mining Co., Ltd., 277-1, Tobuki-cho, Hachioji-shi, Tokyo 192

\*\*Research Center for Advanced Science and Technology, The University of Tokyo, 4-6-1, Komaba, Meguro-ku, Tokyo 153

## 多孔質ガラス担体に固定化した水銀還元酵素の作製及びその特性

宇尾基弘・沼田雅彦\*・鈴木正康\*\*・民谷栄一\*\*・軽部征夫\*\*・牧島亮男

東京大学工学部材料学科, 113 東京都文京区本郷 7-3-1

\*同和鉱業(株)中央研究所, 192 東京都八王子市戸吹町 227-1

\*\*東京大学先端科学技術研究センター, 153 東京都目黒区駒場 4-6-1

[Received November 15, 1991; Accepted January 24, 1992]

The immobilized mercuric reductase covalently coupled to porous glass was prepared and its properties were investigated. Mercuric reductase immobilized on arylamino and carboxyl derivatives exhibited high relative activities about 20-30% compared with soluble enzymes. The optimum pH of mercuric reductase immobilized on these derivatives was 7.5, slightly higher than that of soluble state (7.0-7.2). The stability of mercuric reductase increased with immobilization onto arylamino derivative and the immobilized enzyme maintained at 30°C for 29 days showed 80-90% of initial activity. As the application of immobilized enzyme, mercuric ion sensor was prepared and it was found that mercuric ion higher than 0.5 μM was detectable with this sensor.

**Key-words :** Mercuric reductase, Porous glass, Immobilized enzyme, Carrier, Activity, pH profile, Stability, Mercuric ion sensor

### 1. Introduction

Enzymes are useful as catalysts and analytical reagents because of their high catalytic reaction rate and substrate selectivity. Most of enzymes are employed in solution. In these cases, enzymes are wasted after reaction and never reused. Thus, immobilization techniques on insoluble carriers are important for effective utilization of enzymes. So far, many successful attempts have been made for immobilization of enzymes using cellulose, polyacrylamide as carrier materials. Porous glass is considered as one of the most useful carrier materials because of its chemical durability and controlled micro-structure. Currently, porous glass beads called "CPG" are available for carriers of enzymes. This type of porous glass is usually prepared from sodium borosilicate glass with high silica content (ca. 60 wt%). Hammel et al.<sup>1)</sup> reported another type of porous glass which is made of relatively low silica content (ca. 40 wt%) sodium borosilicate glass. As this porous glass has large pore

volume up to 0.6 cm<sup>3</sup>/g, it is suitable for carrier material. Thus, we studied the possibility of the porous glass made of low silica content sodium borosilicate glass as carrier of enzyme immobilization.

In this investigation, the mercuric reductase was immobilized on the porous glass and its properties were studied. As application of this immobilized mercuric reductase, mercuric ion sensor was also investigated. Mercury and its derivatives are highly toxic for human body. Thus development of highly sensitive and rapid measurement of mercury in environment is important.

In this paper, following abbreviations are used  
room temperature: R. T.  
mercuric reductase: MR  
immobilized mercuric reductase: IMR  
sodium phosphate buffer: Na-P buffer  
Tris(hydroxymethyl)aminomethane: Tris

### 2. Materials and methods

#### Mercuric reductase

The mercuric reductase (NADPH-Hg(II) oxidoreductase; EC1.16.1.1) was purified by Fox's method<sup>2)</sup> from *Escherichia coli* that was transformed by pM609 (containing mercuric reductase gene from transposon Tn501). The overall reaction catalyzed with the mercuric reductase is as follows:

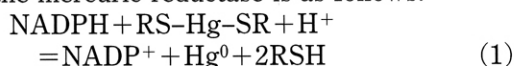

In this reaction, dimercaptide of mercuric ion (Hg<sup>2+</sup>) is reduced by NADPH and NADPH itself is oxidized to NADP<sup>+</sup>. Thus the concentration of mercuric ion can be estimated by concentration change of NADPH.

#### Preparation of porous glass

The porous glass was prepared by heat-treating and leaching Na<sub>2</sub>O·49B<sub>2</sub>O<sub>3</sub>·39SiO<sub>2</sub>·2NaCl (wt%) glasses. Sodium chloride was added to sodium borosilicate system as the accelerator of phase separation.

Table 1. Properties of porous glasses.

|                       |   |
|-----------------------|---|
| Pore diameter         | : 350 Å ~ 2000 Å                              |
| Specific surface area | : 20 m <sup>2</sup> /g ~ 70 m <sup>2</sup> /g |
| Pore volume           | : 55% ~ 56%                                   |

ration and leaching treatment.<sup>3)</sup> Properties of the porous glasses are shown in Table 1. All samples were crushed into small pieces and fractions between 0.044 mm to 0.105 mm in particle diameter were supplied for the following surface treatments.

#### Preparation of glass derivatives

For enzyme immobilization, surface treatments of porous glasses were carried out as follows. In order to prepare alkylamine glasses, the porous glass samples were refluxed overnight in toluene containing 5 % solution of 3-aminopropyltriethoxysilane at 80°C and washed with toluene and dried. The following four kinds of derivatives were prepared for enzyme immobilization.<sup>4)</sup>

##### (1) Glutaraldehyde bound glass

5 % solution of glutaraldehyde in 0.1 M Na-P, pH 7.0 buffer was added to 10 mg of alkylamine glass and the mixture was shaken for 1 h at R. T. and washed with distilled water.

##### (2) Arylamino derivative

1 g of alkylamine glass was refluxed in chloroform containing 5 % of p-nitrobenzoylchloride and 10 % of triethylamine solution at 68°C for 24 h. The product was filtered and washed with chloroform and dried. 0.5 M NaHCO<sub>3</sub> + 0.1 M Na<sub>2</sub>S<sub>2</sub>O<sub>4</sub> solution (pH 8.5, 10 ml) was added to arylamino glass and reacted at 37°C for 1 h. And the product was refluxed in 5 % Na<sub>2</sub>S<sub>2</sub>O<sub>4</sub> solution at 100°C for 20 min and washed with distilled water and dried. 10 mg of the arylamine glass was diazotized by adding 1 ml of 4 N HCl and 10 mg of NaNO<sub>2</sub> at 4°C for 1 h. After diazotization, the glass was washed with distilled water.

##### (3) Carboxyl derivative

0.2 g of succinic anhydride solution (7 ml) was adjusted to pH 6.0 with 20% of NaOH solution. 1 g of alkylamine glass was treated in this solution at 4°C for 5 h. The product was filtered and washed with distilled water and dried. 10 mg of this carboxyl derivative was immersed in distilled water for MR immobilization.

##### (4) Lysine bound glass

0.2 ml of 1 μM dl-lysine (pH 5.0 by HCl) and 2 mg of carbodiimide were added to 10 mg of alkylamine glass and held at 4°C for 3 h and washed with distilled water.

#### Immobilization of mercuric reductase

MR containing 0.1 M Na-P buffer solution (pH=7.0) was prepared to be 10 μM of MR in concentration. 0.1 ml of this solution was added to 10 mg of porous glass derivatives. These samples were maintained overnight at 4°C for MR immobilization. After immobilization treatment, glass samples and supernatants were separated. Immobilized amount

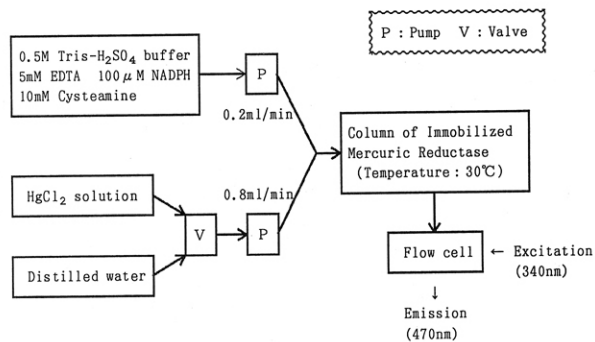

Fig. 1. Flow system of mercuric ion sensor.

of MR was calculated by amount of residual MR in supernatant. The amount of residual MR was determined with absorbance of supernatant at 455 nm.

#### Immobilized enzyme assays

The assays of immobilized enzymes were carried out at 30°C in 0.1 M Na-P, pH 7.0 buffer containing 200 μM NADPH, 100 μM HgCl<sub>2</sub> and 1 mM 2-mercaptoethanol. The reaction rates of mercuric reduction as Eq. (1) were estimated by decrease in NADPH concentration in 5 min. The activities of immobilized mercuric reductase were estimated with these reaction rate by comparison with soluble mercuric reductase.

#### Preparation of mercuric ion sensor

The mercuric ion sensor system was designed by a flow analysis system as shown in Fig. 1. Arylamino derivative of porous glass (particle diameter: 0.212 mm to 0.3 mm, pore diameter: 1300 Å) was used as carrier.  $6 \times 10^{-9}$  mol of MR was immobilized on 0.17 g of porous glass carrier by azo coupling and the IMR was filled in column (3 mm in diameter and 50 mm in length). Temperature of the column was maintained at 30°C. The 0.5 M Tris-H<sub>2</sub>SO<sub>4</sub> buffer solutions (pH=8.0) containing 10 mM cysteamine, 0.1 mM NADPH and 5 mM EDTA and aqueous solution containing various contents of HgCl<sub>2</sub> were carried with peristaltic pump in flow rates of 0.8 ml/min and 0.2 ml/min, respectively. These solutions were mixed and supplied to the IMR column. Concentration of NADPH was determined by fluorometry (excitation wavelength was 340 nm and emission wavelength was 470 nm).

### 3. Results and discussion

#### 3.1 Immobilization rate and relative activity of IMR

Figure 2 shows the immobilization rate of MR with various immobilization methods. Immobilization rate was calculated from amount of immobilized MR by comparing with amount of initially added MR in the immobilization process. The immobilization rate was mainly affected by the immobilization method and most of MR was immobilized on glutaraldehyde bound glass and arylamino glass and it was independent of the pore diameter of porous glass carri-

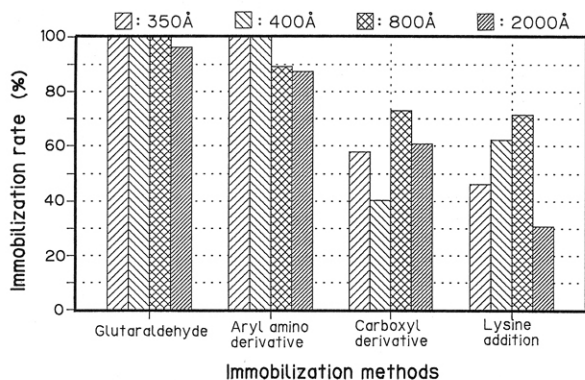

Fig. 2. Effects of immobilization methods and pore diameters of porous glass carriers on immobilization rate of MR.

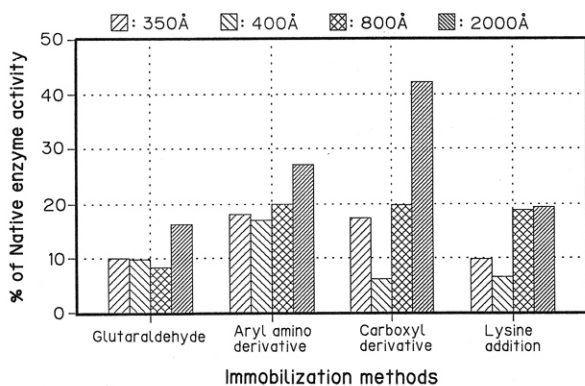

Fig. 3. Effects of immobilization methods and pore diameters of porous glass carriers on relative activity of IMR.

er.

Figure 3 shows the effects of immobilization methods and pore diameters of porous glass carriers on relative activity of IMR. The relative activity was estimated by immobilized amount of MR. High relative activities were observed for the IMR on arylamino derivatives and carboxyl derivatives comparing with that on other derivatives and the activities were ranging from about 20% to 30% comparing with soluble MR. Considering amounts of immobilized MR, immobilization onto arylamino derivative is useful to prepare an IMR of high activity. Relative activity of IMR tends to increase with increasing pore diameter of porous glass carrier.

### 3.2 pH profile of IMR

The pH profiles of IMR on arylamino and carboxyl derivatives were determined. The pH was varied from 5.5 to 9.2 with Na-P and Tris-HCl buffer. The pH profiles are shown in Fig. 4 and optimum pH of immobilized MR were determined as pH=7.5. The optimum pH of soluble MR is about 7.0–7.2, thus optimum pH was slightly shifted to higher pH with immobilization. The same effect was reported by Mason et al.<sup>5)</sup> for immobilized invertase. As a cause of this shift of the optimum pH, Mason et al. suggested that the pH of surface of the carrier was more acidic

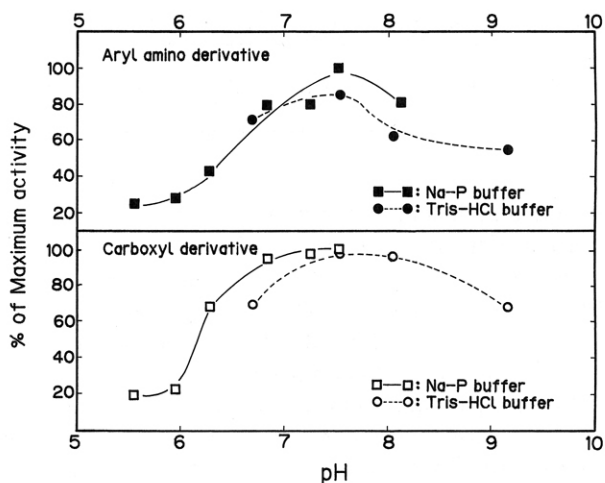

Fig. 4. pH profiles of IMR.

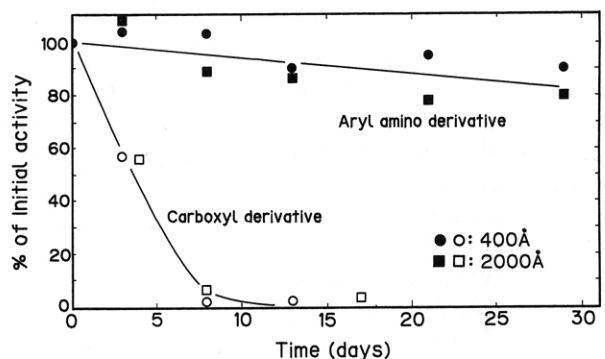

Fig. 5. Stability of IMR maintained at 30°C.

than that of bulk solution because of residues as alkylamine group.

### 3.3 Stability of IMR

The stabilities of IMR was estimated by change in activity. IMR was maintained at 30°C for 29 days. As shown in Fig. 5, the activity of IMR on carboxyl derivative was disappeared in 8 days whilst the activity of IMR on arylamine derivative was slightly decreased to 80–90% of the initial value on 29 days after immobilization. In case that soluble MR is maintained at 30°C for 29 days, its activity decreased to half of the initial value. Thus, the MR became more stable by the immobilization at around R.T.

### 3.4 Application to mercuric ion sensor

Figure 6 shown the relationship between  $\text{HgCl}_2$  concentration and decrease in NADPH concentration. A linear relation was observed between 0.5  $\mu\text{M}$  to 8  $\mu\text{M}$  in  $\text{HgCl}_2$  concentration. The line in Fig. 6 shows decrease in NADPH concentration when  $\text{HgCl}_2$  is reduced completely. In this experiment, most of mercuric ion was reduced in low  $\text{HgCl}_2$  concentration range below 5  $\mu\text{M}$ .

Thus, it was found that mercuric ion higher than 0.5  $\mu\text{M}$  (0.1 ppm Hg) was detectable with this mercuric ion sensor. Since this mercuric ion sensor is

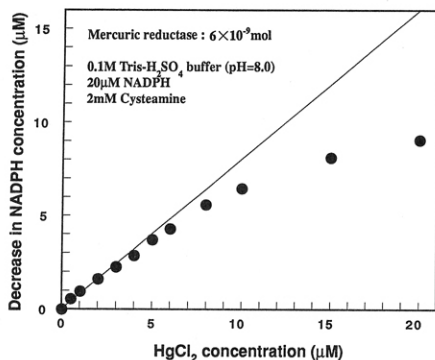

Fig. 6. Relationship between  $HgCl_2$  concentration and decrease in NADPH concentration.

designed with simple flow analysis system and continuous measurement is possible without any sample pre-treatment, this sensor considered useful for mercury analysis.

#### 4. Conclusions

The immobilized mercuric reductase covalently coupled to porous glass was prepared and its properties were investigated. Immobilized mercuric reductase on arylamino and carboxyl derivatives exhibited high relative activity of about 20% to 30% comparing with soluble enzyme. Relative activity increased with increasing pore diameter of porous glass carri-

er. The optimum pH of mercuric reductase immobilized on these derivatives were 7.5 and slightly shifted to higher pH with respect to that in soluble state (7.0–7.2). The stability of mercuric reductase was changed with immobilization. The activity of mercuric reductase immobilized on carboxyl derivative disappeared in one week. Contrarily to this, that on arylamino derivative maintained at 30°C for 29 days exhibited 80–90% of the initial activity showing that the immobilization of MR increases the stability. Using the immobilized mercuric reductase on arylamino derivative of porous glass, the mercuric ion sensor was assembled with flow analysis system. With this sensor, it was found that mercuric ion higher than 0.5  $\mu$ M (0.1 ppm Hg) is detectable.

**Acknowledgement** The authors would like to acknowledge Dr. H. Inoue of The University of Tokyo for much helpful advice in the preparation of this manuscript.

#### References

- 1) J. J. Hammel and T. Allersma, US Pat. 3,843,341 (1974).
- 2) B. Fox and C. T. Walsh, *J. Biol. Chem.*, **257**, 2498–503 (1982).
- 3) M. Uo, Y. Yamashika, K. Morita, I. Karube and A. Makishima, *J. Ceram. Soc. Japan*, **100**, 17–21 (1992).
- 4) D. A. Lappi, F. E. Stolzenbach and N. O. Kaplan, *Biochem. Biophys. Res. Commun.*, **69**, 878–84 (1976).
- 5) R. D. Mason and H. H. Weetall, *Biotechnol. Bioeng.*, **14**, 637–45 (1972).