



Title	GABAergic signaling in the developing cerebellum
Author(s)	Takayama, Chitoshi
Citation	GABA in Autism and Related Disorders (International Review of Neurobiology 71), 63-94 https://doi.org/10.1016/S0074-7742(05)71003-5
Issue Date	2005
Doc URL	https://hdl.handle.net/2115/17189
Rights	Reprinted from International Review of Neurobiology, Vol. 71, Chitoshi Takayama, GABAergic Signaling In The Developing Cerebellum , pp. 63-94, Copyright 2005, with permission from Elsevier.
Type	journal article
File Information	IRN71.pdf



International Review of Neurobiology

GABAergic signaling in the developing cerebellum

Chitoshi Takayama

Department of Molecular Neuroanatomy, Hokkaido University School of Medicine, Sapporo
060-8638, Japan

Running title: Development of cerebellar GABAergic signaling

Number of text pages: 41, Figures: 10, Table:1

Address for the correspondence and proofs to:

Chitoshi Takayama

Department of Molecular Neuroanatomy, Hokkaido University School of Medicine,
Kita-15 Nishi-7, Kita-Ku, Sapporo 060-8638, Japan

Phone +81-11-706-5028

Fax +81-11-706-7863

E-mail takachan@med.hokudai.ac.jp

Abstract

In the adult central nervous system (CNS), γ -amino butyric acid (GABA) is the predominant inhibitory neurotransmitter, and it regulates glutamatergic activity. Recent studies have revealed that GABA serves as an excitatory transmitter in the immature CNS, and acts as a trophic factor for brain development. Furthermore, normal formation of GABAergic synapses is crucial for the expression of higher brain functions such as memory, learning and motor coordination, and various psychiatric diseases such as anxiety disorders, epilepsy, schizophrenia and autism are partly caused by the dysfunction of GABA in the developing and mature brain. These results indicate that the GABAergic roles change developmentally with special references to alterations in GABAergic transmission and signaling, and that GABA plays various roles in the expression of almost all brain functions. We morphologically investigated the developmental changes in the GABAergic transmission system and the key factors for the formation of GABAergic synapses and networks. Here, we focus on the cerebellar cortex, which provides an ideal system for the investigation of brain development, and review four points: (1) The GABAergic system in the adult cerebellum, (2) GABAergic signaling before synaptogenesis -the mechanisms by which GABA exerts its effect on developing neurons-, (3) Formation of GABAergic synapses -mechanisms underlying formation of functional GABAergic synapses-, and (4) Functions of GABAergic synapses.

Key Words: GABA_A receptor, GABA transporter, GABAergic synapse, GABAergic vesicle, morphogenesis, and inhibitory transmission

I Introduction

In the mammalian central nervous system (CNS), GABA is the predominant neurotransmitter, and it plays various roles in the expression of brain functions by activation of ionotropic and metabotropic GABA receptors. In the adult CNS, GABA mediates inhibitory synaptic transmission, regulates glutamatergic activity and prevents hyperexcitation (Kardos, 1999; Macdonald and Olsen, 1994; Olsen and Avoli, 1997). In the developing CNS, GABA acts as trophic factor, and induces brain morphogenesis, including changes in cell proliferation, cell migration, axonal growth, synapse formation, steroid-mediated sexual differentiation and cell death (Barker et al., 1998; Belhage et al., 1998; Ben-Ari, 2002; Kardos, 1999; McCarthy et al., 2002; Owens and Kriegstein, 2002; Varju et al., 2001). Furthermore, during the maturation period, GABAergic transmission controls experience-dependent plasticity in the visual cortex, induces long-term potentiation, which is the electrophysiological basis of memory and learning (Ben-Ari et al., 1997; Fagiolini and Hensch, 2000; Freund and Gulyas, 1997; Hensch et al., 1998; Kardos, 1999; McBain and Maccaferri, 1997; Paulsen and Moser, 1998; Wolff et al., 1993), modulates anxiety (Nutt *et al.*, 1990; Pratt, 1992), and generates circadian rhythms (Nutt et al., 1990; Pratt, 1992; Turek and Van Reeth, 1988; Wagner et al., 1997). Various psychiatric diseases such as epilepsy (Avoli, 2000; Baulac et al., 2001; Snead et al., 1999; Wallace et al., 2001), anxiety disorders (Freeman et al., 2002; Millan, 2003; Nutt, 2001), schizophrenia (Berry et al., 2003; Blum and Mann, 2002; Byne et al., 1999; Caruncho et al., 2004; Costa et al., 2004; Lewis et al., 2004; Wassef et al., 2003) and autism (Blatt et al., 2001; Cook et al., 1997; DeLorey et al., 1998; Dhossche et al., 2002; Dhossche, 2004; Fatemi et al., 2002; Lauritsen et al., 1999; Rolf et al., 1993), are partially caused by GABA dysfunction in the developing and mature brain.

The developmental shift in the action of GABA is based on an alteration in

GABAergic transmission and signaling. During development, the GABA transmitter system changes from non-synaptic to synaptic mechanisms (Attwell et al., 1993; Fon and Edwards, 2001; Owens and Kriegstein, 2002; Taylor and Gordon-Weeks, 1991; Varju et al., 2001). The subunit compositions and localization of ionotropic GABA receptors drastically change (Araki et al., 1992; Fritschy et al., 1994; Gambarana et al., 1990; Laurie et al., 1992a; Ma and Barker, 1995; Maric et al., 1997). Environmental changes, such as decreasing intracellular chloride concentration, influence the response of GABA receptors (Ben-Ari, 2002; Cherubini et al., 1991; Ganguly et al., 2001; Owens and Kriegstein, 2002; Perkins and Wong, 1997; Rohrbough and Spitzer, 1996; Serafini et al., 1998). In the first half, we review the GABAergic system in the cerebellum and the developmental changes in GABAergic signaling, and discuss how GABA exerts its effect on immature neurons during development. Establishment of GABAergic synapses is crucial for the expression of normal and higher brain functions. In the second half, we address the key factors for the formation of functional GABAergic synapses, and discuss the mechanisms underlying the formation of GABAergic synapses and networks.

II GABAergic system in the cerebellar cortex

1. GABAergic neurons and synapses

The cerebellar cortex consists of molecular, Purkinje cell and granular layers (Ito, 1984; Llinas and Walton, 1990; Palay and Chan-Palay, 1974). Each layer contains distinct types of neurons. Stellate cells are scattered in the molecular layer, and basket cells are localized in the deep part of the molecular layer. Cell bodies of Purkinje cells are arranged in a single layer between the molecular and granular layers. Numerous granule cells occupy the granular layer and Golgi cells are localized mainly in the upper half of the granular layer.

Among the five types of main neurons, four of them, Purkinje, stellate, basket and Golgi cells, release GABA as a neurotransmitter (Fig. 1A, B). The GABAergic neurons and the neural circuits in the cerebellar cortex are summarized in Figure 1B (Ito, 1984; Llinas and Walton, 1990; Palay and Chan-Palay, 1974).

The Purkinje cell is a pivotal neuron in the cerebellar cortex. Each dendrite spreads out in a single vertical parasagittal plane in the molecular layer, and receives excitatory inputs from climbing and parallel fibers at the spines, and inhibitory inputs from stellate cells at the shafts. Cell bodies form GABAergic synapses with the pericellular baskets of basket cell axon collaterals. The Purkinje cell axons traverse the granular layer into the white matter, and innervate the deep cerebellar and vestibular nuclei. In addition, recurrent collateral branches arise from the third or fourth nodes of Ranvier (Cajal, 1911), ramify in the upper granular layer, and give rise to plexuses beneath the Purkinje cell bodies. In the plexus, varicosities of axon collaterals form GABAergic synapses with Purkinje and Golgi cells at the cell bodies and dendrites (Palay and Chan-Palay, 1974; Takayama and Inoue, 2004a).

Each stellate and basket cell extends its dendrite only in a parasagittal plane parallel to the fan of the Purkinje cell dendrite within the molecular layer. They receive excitatory inputs from parallel and climbing fibers and inhibitory inputs from stellate cells. The stellate cell axons arborize within the molecular layer, and their varicosities make many GABAergic synaptic contacts with the dendritic shafts of Purkinje cells and other GABAergic neurons, including stellate, basket and Golgi cells. Basket cell axons run deep in the molecular layer just above the cell bodies of Purkinje cells. Axon collaterals descend along the Purkinje cell dendrites, surround the Purkinje cell bodies, give rise to pericellular baskets, and form periaxonal plexuses, '*pinceau*', around the initial segment of the Purkinje cell axon (Cajal, 1911). At the pericellular basket, axo-somatic synapses are formed with Purkinje cell bodies.

At the *pinceau*, axo-axonic synapses are formed with the initial segments of Purkinje cells. Both synapses are GABAergic. One basket cell axon innervates about 10 Purkinje cells.

Golgi cells extend their dendrites into the molecular layer. Each Golgi cell dendrite is not confined to a single plane, but opens out into a three-dimensional unguated field. They receive excitatory input from parallel and climbing fibers in the molecular layer and mossy fibers in the granular layer. Inhibitory inputs come from stellate cells in the molecular layer and Purkinje cell axon collaterals in the granular layer. One to three axons arise from the cell body and main dendrite, divide repeatedly and give rise to plexuses. At the plexuses, varicosities of Golgi cell axons form GABAergic synapses with granule cell dendrites at the peripheral part of the glomeruli in the granular layer.

The pivotal neurons of the cortex, Purkinje cells, receive excitatory inputs from climbing fibers and granule cell axons, parallel fibers, and send inhibitory output to the deep cerebellar nucleus. GABAergic neurons, stellate, basket and Golgi cells, negatively regulate above the major stream of cortical circuits at the Purkinje cell dendrites, cell bodies, and granule cell dendrites, respectively.

2. GABA and GABA receptors

In the CNS, GABA is synthesized from glutamate by two isoforms of glutamic acid decarboxylase (GAD65 and GAD67) (Barker et al., 1998; Martin and Rimvall, 1993; Varju et al., 2001), and is loaded into vesicles by the vesicular GABA transporter (VGAT) (Fig.2) (Fon and Edwards, 2001; McIntire et al., 1997; Reimer et al., 1998). In response to the influx of calcium ion via a voltage-dependent calcium channel, GABA is released by the fusion of vesicles with the presynaptic membrane at the nerve terminals, and activates GABA receptors at the postsynaptic membrane. GABAergic signals are terminated by reuptake of neurotransmitter into nerve terminals or uptake into surrounding glia by plasma membrane

GABA transporters (GATs) (Cherubini and Conti, 2001).

GABA receptors are classified into three groups on the basis of pharmacology and biochemistry; GABA_A, GABA_B and GABA_C. Among them, fast synaptic transmission is mediated by ionotropic GABA receptors, GABA_A and GABA_C receptors (Bormann, 2000; Kaupmann et al., 1998; Macdonald and Olsen, 1994; Mehta and Ticku, 1999). The GABA_A receptor is a member of the ligand-gated ion channel receptor family, and is thought to be composed of five heteromeric subunits belonging to seven different subunit families; α 1-6, β 1-3, γ 1-3, δ , ϵ , π , and θ (Macdonald and Olsen, 1994; Mehta and Ticku, 1999; Nayeem et al., 1994; Olsen and Tobin, 1990; Sieghart, 1995; Sieghart et al., 1999; Tretter et al., 1997). Native GABA_A receptors contain at least one α -, one β -, and one γ -subunit with the δ -, ϵ -, π -, and θ -subunits to substitute for the γ subunit (McKernan and Whiting, 1996; Pritchett et al., 1989; Sieghart, 1995; Sieghart et al., 1999). The subunit compositions drastically change during brain development (Araki et al., 1992; Gambarana et al., 1990; Laurie et al., 1992a), and exhibit characteristic pharmacological and electrophysiological properties. (Kardos, 1999; Luddens et al., 1990; Macdonald and Olsen, 1994; Olsen and Tobin, 1990; Pritchett et al., 1989; Sieghart, 1995; Vicini, 1999). GABA binding opens the pore of GABA receptors and induces influx or efflux of anions such as chloride ion (Fig. 2) (Kardos, 1999; Macdonald and Olsen, 1994; Olsen and Tobin, 1990; Sieghart, 1995). The GABA_C receptor is also an ion-channel type receptor, which is composed of only single or multiple ρ subunits. The GABA_C receptor is identified as a bicuculline and baclofen insensitive GABA receptor, and is considered to be a pharmacological variant of GABA_A receptors (Bormann, 2000; Bormann and Feigenspan, 1995; Mehta and Ticku, 1999). The GABA_B receptor, which includes three isoforms, R1a, R1b, and R2 (Kaupmann et al., 1997; Kaupmann et al., 1998), is a metabotropic receptor, activates G proteins, negatively regulates the second messenger system,

and responds to slow acting inhibition of channel and receptor functions (Bormann, 1988; Connors et al., 1988; LeVine, 1999; Nicoll, 1988).

3. GABA_A receptors in the cerebellar cortex

All neurons in the cerebellar cortex express the GABA_A receptors. The main composition of the GABA_A receptors is $\alpha 1\beta 2\gamma 2$ (Fritschy and Mohler, 1995; Laurie et al., 1992a; Persohn et al., 1992). In addition, Purkinje cells abundantly express the $\beta 3$ subunit ($\alpha 1\beta 2/3\gamma 2$), and granule cells abundantly express the $\alpha 6$, $\beta 3$ and δ subunits ($\alpha 1/6\beta 2/3\gamma 2/\delta$) (Fig. 1B).

4. Plasma membrane GABA transporters

Plasma membrane GABA transporters (GATs) are high-affinity, sodium (Na^+) and chloride (Cl^-)-dependent transporters, and GABA is co-transported with Na^+ and Cl^- (Borden, 1996; Conti et al., 2004; Gadea and Lopez-Colome, 2001; Kanner, 1994). Molecular cloning has isolated four GATs, GAT-1, GAT-2, GAT-3 and BGT-1. (Mouse GAT2, GAT3 and GAT4 are the species homolog of rat BGT-1, GAT-2 and GAT-3, respectively.) They exhibit characteristic distributions in the CNS, including the cerebellum (Durkin *et al.*, 1995; Itouji *et al.*, 1996; Morara *et al.*, 1996; Ribak *et al.*, 1996; Rosina *et al.*, 1999). GAT-1 is mainly localized at the axon terminals containing GABAergic vesicles and is partly detected at the astrocytes (Fig. 3A, B). In contrast, GAT-3 is localized at the processes of astrocytes in the granular layer (Fig. 3C, D). GAT-2 is only localized at the leptomeningeal, ependymal cells and choroids plexus (Conti *et al.*, 1999).

In the adult CNS, GATs clean GABA from the synaptic cleft into the presynapse or surrounding glia (Fig. 2). In the immature brain or under abnormal condition such as ischemia and seizure, on the other hand, GATs work in reverse, releasing neurotransmitters (Attwell et al., 1993; Levi and Raiteri, 1993), in a calcium independent mechanism. It is thought that this

phenomenon induces the development and protects against the effects of seizures (Phillis *et al.*, 1994).

III GABAergic signaling before synaptogenesis

1. Extrasynaptic GABA release in the developing cerebellum

In the developing CNS, GABA appears in GABAergic neurons long before the onset of synaptogenesis (Fairen *et al.*, 1998; Lauder, 1993; Lauder *et al.*, 1986; Van Eden *et al.*, 1989) and its subcellular localization gradually changes during brain development (Behar *et al.*, 1993; McLaughlin *et al.*, 1975; Takayama and Inoue, 2004b). In the cerebellum, before GABAergic synapses are formed, GABA is distributed throughout the GABAergic neurons, including cell bodies, dendrites, axons, axon varicosities, and growth cones (Takayama and Inoue, 2004a; Takayama and Inoue, 2004c) (Fig. 3A, 4A). VGAT, which is a membrane protein of GABAergic vesicles and transports cytosolic GABA into the vesicles (Chaudhry *et al.*, 1998; Dumoulin *et al.*, 1999; Fon and Edwards, 2001; Reimer *et al.*, 1998; Takamori *et al.*, 2000), accumulates at the axon varicosities and growth cones where GABAergic synapse are not yet formed (Fig. 3B, C, 4B, C) (Takayama and Inoue, 2004a). This indicates that GABA is distributed throughout GABAergic neurons, and vesicular GABA accumulates to the axon varicosities and growth cones. During synapse formation, GABA becomes confined to the axon terminals, and gradually disappears from axons themselves as well as dendrites. After finishing synapse formation, GABA is almost completely co-localized with VGAT at the synaptic sites where the GABA_A receptor $\alpha 1$ subunit accumulates (Fig. 3D-F). This indicates that most GABA is exclusively localized in the synaptic vesicles within the axon terminals.

Physiological and biochemical studies have demonstrated that the non-vesicular form of GABA is also secreted via the plasma membrane by reverse transporter actions of GATs

(Fig. 4D) (Attwell et al., 1993; Behar et al., 1993; Belhage et al., 1993; Gao and van den Pol, 2000; Jaffe and Vaello, 1988; Taylor et al., 1990; Taylor and Gordon-Weeks, 1991; Varju et al., 2001). In the developing brain, GABA could be released in two ways: exocytosis of GABAergic vesicles, and diacrine of cytosolic GABA via plasma membrane (Fig. 5D). It was hypothesized that cytosolic GABA might be extrasynaptically released from dendrites, axons and cell bodies via the plasma membrane by GATs, and GABA in the vesicles might be also extrasynaptically released from axon varicosities and growth cones (Varju, *et al.*, 2001).

To clarify which type of release occurs in the developing cerebellum, we examined the changes in distribution of the plasma membrane GABA transporters in the developing cerebellum (Takayama and Inoue in submission). We could not find GAT-1 or GAT-3 in the dendrites and cell bodies in the developing GABAergic neurons (Fig. 6). GAT-1 first appears in the granular layer and subsequently in the Purkinje and molecular layers, localizing at axons, varicosities, and terminals (Fig. 6A-F). GAT-3 appears at P10 in the deep part of the granular layer and localized in the processes of astrocytes (Fig. 6F, G). These localizations are the same as those in the adult cerebellum (Durkin et al., 1995; Itouji et al., 1996; Morara et al., 1996; Ribak et al., 1996; Rosina et al., 1999). These results suggest that GABA is synthesized throughout the GABAergic neurons and transported into vesicles but is not released by diacrine. GABA in the vesicles is confined to the axon varicosities and growth cones and released by exocytosis in the developing cerebellum (Fig. 7A). The exocytosis trigger is unknown. In the mature cerebellum, on the other hand, most GABA is synthesized at the terminals, including varicosities, where synapses are formed and is released at the synapse (Fig. 7B).

Furthermore, the GABA-removing system might shift as shown in Figure 7C-E. Before synapse formation, GABA is released from axon varicosities and growth cones of

GABAergic neurons and disappears by diffusion (Fig. 6C). During synaptogenesis, GAT-1 mediates the reuptake from the extracellular space into the axons and presynapses (Fig. 7D). Finally, GABA is removed from synaptic clefts into the presynapse by GAT-1 and astrocytes by GAT-3. These results indicate that plasma membrane GATs might not be involved in the diacrine process, but only uptake of GABA from synaptic clefts in the cerebellum.

2. GABAergic roles in the developing brain

During brain development, extrasynaptically released GABA diffuses in the extracellular space and activates GABA receptors on neighboring neurons. The activation of GABA_A receptors depolarizes membrane potential, since the Cl⁻ reversal potential of the neuronal membrane is elevated (Fig. 8A) (Ben-Ari, 2002; Cherubini et al., 1991; Leinekugel et al., 1999; Owens and Kriegstein, 2002; Perkins and Wong, 1997; Rohrbough and Spitzer, 1996; Serafini et al., 1998). In the developing CNS, Na⁺-K⁺-2Cl⁻ co-transporter 1 (NKCC1), which raises the concentration of intracellular chloride ion, [Cl⁻]_i, is predominantly expressed, and elevates the equilibrium potential of Cl⁻. Under the high [Cl⁻]_i condition, the activation of GABA_A receptors generates efflux of chloride ion and depolarization of membrane potential (Fig.8A). In contrast, K⁺-Cl⁻ co-transporter 2 (KCC2), which lowers the [Cl⁻]_i, becomes a predominant chloride co-transporter in the mature CNS, and GABA induces hyperpolarization of membrane potential and inhibition of excitability (Fig. 8B).

GABA_A-receptor-mediated depolarization in the immature CNS activates voltage-dependent Ca⁺⁺ channels (VDCC) and/or N-methyl-D-aspartate (NMDA) type glutamate receptors, and elevates cytosolic Ca⁺⁺ ion (Fig. 8A) (Ben-Ari et al., 1997; Connor et al., 1987; Eilers et al., 2001; Leinekugel et al., 1995; Obrietan and van den Pol, 1996; Reichling et al., 1994; Serafini et al., 1998; Yuste and Katz, 1991). The elevation of cytosolic calcium effects various steps in CNS development such as (1) cell proliferation, (2) cell

migration, and (3) neuronal maturation, including synaptogenesis (Barker et al., 1998; Belhage et al., 1998; Ben-Ari, 2002; Kardos, 1999; McCarthy et al., 2002; Owens and Kriegstein, 2002; Varju et al., 2001). GABA acts as an anti-proliferation molecule, reduces the DNA synthesis in the proliferating precursor cells, and depresses the rate of cellular proliferation by the activation of GABA_A receptors and other GABA_A-receptor related molecules (Haydar et al., 2000; LoTurco et al., 1995). GABA modulates neuronal migration by 'chemotaxis' and 'chemokinesis' at the femtomolar (10^{-15} M) and micromolar (μ M) level, respectively (Behar et al., 1996; Behar et al., 1994; Behar et al., 1995). Activation of GABA_B and GABA_C receptors promotes migration out of the proliferating layer, whereas that of the GABA_A receptor slows or almost stops the movement in the cortical plates (Behar *et al.*, 2000). Furthermore, exposure of neurons to GABA or GABA_A receptor agonists induces the synthesis of neuron specific molecules such as neuron-specific enolase (NSE) and neural cell adhesion molecules (NCAMs), enhances the growth rate of neuronal processes, and facilitates synapse formation by inducing the expression and targeting of GABA receptor subunits, which mediate synaptic transmission (Abraham and Schousboe, 1989; Barbin et al., 1993; Belhage et al., 1998; Carlson et al., 1997; Carlson et al., 1998; Elster et al., 1995; Gao and van den Pol, 2000; Kim et al., 1993; Meier and Jorgensen, 1986; Meier et al., 1987; Mellor et al., 1998; Mitchell and Redburn, 1996; Moss and Smart, 2001; Spoerri, 1988; Wolff et al., 1978). In the case of interneurons and their networks, GABA might stimulate the expression of neurotrophins, such as brain derived neurotrophic factors (BDNF) and their receptors, trks, and enhance the growth of neurons and synapses (Berninger et al., 1995; Marty et al., 1996; Rico et al., 2002; Vicario-Abejon et al., 1998).

In the cerebellum, the above change in the chloride ion concentration system could not be clarified (Eilers et al., 2001; Kanaka et al., 2001; Lu et al., 1999; Mikawa et al., 2002;

Williams et al., 1999). However, GABA could be also involved in morphogenesis in the cerebellum since GABA elevates the Ca^{++} ion concentration in the Purkinje and granule cells during the first two postnatal weeks (Connor et al., 1987; Eilers et al., 2001).

3. GABA_A receptor expression in the developing cerebellum

In the CNS, the subunit compositions of GABA_A receptors drastically change during brain development (Ben-Ari et al., 1997; Connor et al., 1987; Eilers et al., 2001; Leinekugel et al., 1995; Obrietan and van den Pol, 1996; Reichling et al., 1994; Serafini et al., 1998; Yuste and Katz, 1991). We focused on the α subunits, which may mainly reflect the functional diversity of the GABA_A receptors (Kardos, 1999; Luddens et al., 1990; Macdonald and Olsen, 1994; Olsen and Tobin, 1990; Pritchett et al., 1989; Sieghart, 1995), and investigated the developmental changes in expression and localization of the GABA_A receptor α subunits in the cerebellum (Table I) (Takayama and Inoue, 2004c; Takayama and Inoue, 2004d). Proliferating cells in the ventricular zone adjacent to the fourth ventricle and the upper half of the external granular layer expressed no α subunits. Since at least one α subunit is essential for functional GABA_A receptors (McKernan and Whiting, 1996; Pritchett et al., 1989; Sieghart, 1995; Sieghart et al., 1999), receptor activity is absent in the proliferating zone. After finishing cell proliferation, cerebellar neurons start to express the functional GABA_A receptors. Differentiating Purkinje cells express the $\alpha 3$ subunit, migrating and maturing granule cells express the $\alpha 2$ subunit, and both subunits disappear from the cerebellar cortex after synapse formation finishes (Takayama and Inoue, 2004d). In addition, the $\beta 3$, $\gamma 1$ and $\gamma 3$ subunits are also abundantly expressed in the developing cerebellum (Laurie, *et al.*, 1992b). These results suggest that extrasynaptically released GABA activates GABA_A receptors consisting of the above restricted subunits, and may be involved in the regulation of proliferation, neuronal migration and maturation in the cerebellum.

4. Conclusion for this section

Before synapse formation, GABA is synthesized throughout the GABAergic neurons, transported into GABAergic vesicles at axon varicosities and growth cones, extrasynaptically released by exocytosis, and diffused within the extracellular space. Released GABA activates GABA receptors consisting of $\alpha 2/3$, $\beta 3$, $\gamma 1/3$ subunits on the neighboring neurons, mediates the depolarization of membrane potential and induces various types of morphogenesis.

IV Formation of GABAergic synapses

Synapse formation is considered to be a multi-step process (Cherubini and Conti, 2001; Moss and Smart, 2001; Vaughn, 1989). While exploring their environment, axonal growth cones lead elongating axons to their appropriate targets and make contact with dendrites and cell bodies of target neurons. Initial contact is followed by the establishment of stable synapses. In the presynapse, synaptic vesicles accumulate to the nerve terminals and dock near the active zone. In the postsynapse, GABA_A receptors which mediate inhibitory synaptic transmission are targeted to and clustered at an appropriate synaptic site opposite the GABA-releasing site. At the same time, GABA_A receptors, which are involved in brain morphogenesis, disappear from postsynaptic neurons (Takayama and Inoue, 2004b; Takayama and Inoue, 2004d).

1. Development of GABAergic synapses in the cerebellar cortex

In the mouse cerebellar cortex, the GABA_A receptor $\alpha 1$ subunit protein, which is an essential subunit of mature GABA_A receptors in Purkinje cells (Laurie et al., 1992a; Persohn et al., 1992), appears at P5 (Takayama and Inoue, 2004c), and symmetric synapses are detected between GAD-positive terminals and Purkinje cell dendrites at the same day (personal unpublished data). In the mouse granular layer, on the other hand, the $\alpha 1$ and $\alpha 6$

subunit proteins, which are essential subunits for the mature GABA_A receptors in the granule cells appear in deep part at P7, and symmetric synapses are clearly discernible at P10 between GAD-positive terminals and granule cell dendrites in the synaptic glomeruli.

These results indicate that in the cerebellum excitatory synapses appear prior to the inhibitory synapses, and GABAergic synapses start to be formed on the Purkinje cell dendrites during the first postnatal week, and granule cell dendrites during the second postnatal week. The number of GABAergic synapses increase dramatically in all layers during the second and third post natal weeks (Altman and Bayer, 1997; Jakab and Hamori, 1988; Larramendi, 1969; Takayama and Inoue, 2004c).

2. Target determination

It is not fully understood how GABAergic neurons search, recognize and determine their target neurons. To reveal how GABAergic neurons determine their targets and form synapses, we employed cerebellar mutant mice and examined the specificity of neuron-to-neuron connection in the mutant cerebellum. In the normal cerebellar cortex, five major types of neurons innervate distinct types of target neurons (Fig. 1B) (Ito, 1984; Llinas and Hillmann, 1969; Palay and Chan-Palay, 1974). The specific innervation patterns, however, are not preserved in the abnormal environment of the reeler and weaver cerebellum (Fig. 9). Golgi cells directly innervate to Purkinje cells in the central mass of the reeler cerebellum and in the cortex of the weaver cerebellum (Caviness and Rakic, 1978; Mariani et al., 1977; Rakic, 1976; Sotelo and Privat, 1978; Takayama, 1994; Wilson et al., 1981). In both regions, granule cells are scarce or absent. Thus, Golgi cell axons form synapses with neighboring neurons instead of granule cells. This result indicates that targets of Golgi cells are not genetically and strictly determined, but are influenced by the environment, and that targets of GABAergic neurons plastically alter according to the environment.

3. Change in subunit compositions

As shown in Table I, expression of the GABA_A receptor α subunits in the cerebellum developmentally changes especially during GABAergic synapse formation. While expression of the $\alpha 2$ and $\alpha 3$ subunits is decreasing, the $\alpha 1$ and $\alpha 6$ subunits appear and increase their expression (Laurie et al., 1992b; Mellor et al., 1998; Takayama and Inoue, 2004c; Takayama and Inoue, 2004d; Tia et al., 1996). Therefore, the α subunits in the GABA_A receptors shift from the $\alpha 2$ and $\alpha 3$ subunits to the $\alpha 1$ and $\alpha 6$ subunits during cerebellar development. This result indicates that two pieces of evidences, the disappearance of subunits involved in morphogenesis, and the appearance of subunits which mediate inhibitory synaptic transmission, are crucial for GABAergic synapse formation.

To test the mechanism underlying the change in subunit compositions, we investigated its relationship with neuronal maturation, including migration, axonal and dendritic extension, and formation of excitatory and inhibitory synapses using reeler mutant mice. In the reeler cerebellum, maturation of malpositioned Purkinje cells is assumed to be arrested in terms of the synaptic architecture and dendritic arborization (Caviness and Rakic, 1978; Mariani et al., 1977; Rakic, 1976; Sotelo and Privat, 1978; Takayama, 1994; Wilson et al., 1981). Parallel fibers and axons from stellate and basket cells do not innervate the Purkinje cells in the central cerebellar mass. Moreover, multiple innervations from climbing fibers remain in the adult reeler cerebellum. Instead, Purkinje cells directly form synapses with mossy fibers and Golgi cell axons. Dendrites of Purkinje cells are poorly developed and extend almost randomly. The $\alpha 3$ subunit, however, is almost negative, as in the normal mature cerebellum (Fig. 9E, F), and malpositioned Purkinje cells abundantly express the $\alpha 1$ subunit (Fig. 9A, B) (Frosthalm *et al.*, 1991; Takayama and Inoue, 2003). These results indicate that developmental change in subunit composition is independent of neuronal maturation such as

settling in the normal neuronal position, maturation of excitatory networks. Absence of normal inhibitory synapses with stellate and basket cell axons and heterologous input from Golgi cells do not affect the developmental changes in subunit composition. Previous in vitro studies have indicated that GABAergic stimulation induces low-affinity type GABA receptor expression, which is involved in inhibitory synaptic transmission (Belhage et al., 1998; Belhage et al., 1986; Carlson et al., 1997; Carlson et al., 1998; Elster et al., 1995; Gao and Fritschy, 1995; Kim et al., 1993; Meier et al., 1984; Mellor et al., 1998; Raetzman and Siegel, 1999; Schousboe, 1999). The change in subunit composition simultaneously occurred during GABAergic synaptogenesis (Table I). These results suggest that innervation of GABAergic fibers may be important for the change in subunit composition, even if the synapses are heterologous and ectopic, and GABAergic innervation might initiate and/or accelerate the changes in subunit composition.

4. Specific subunit expression

In the CNS, distinct types of subunits are expressed at distinct synapses (Fig. 1B) (Laurie et al., 1992a; Persohn et al., 1992; Wisden et al., 1992). In the normal cerebellum, GABAergic transmission between stellate cell axons and Purkinje cell dendrites is mediated by GABA_A receptors containing only the $\alpha 1$ subunit, but not the remaining five α subunits (Fig. 1B) (Laurie et al., 1992a; Persohn et al., 1992; Wisden et al., 1996; Wisden et al., 1992). In contrast, inhibitory transmission between Golgi cell axons and granule cell dendrites is mediated by GABA_A receptors containing both $\alpha 1$ and $\alpha 6$ subunits.

To test the relationship between types of presynapse and subunits in the postsynapse, we examined the expression of GABA_A receptor α subunits in the reeler cerebellum. In the central cerebellar mass of the reeler cerebellum, Purkinje cells directly form synapses with Golgi cell axons (Fig. 9) (Caviness and Rakic, 1978; Mariani et al., 1977; Rakic, 1976; Sotelo

and Privat, 1978; Takayama, 1994; Wilson et al., 1981). If presynaptic neurons determine the type of receptor subunits in postsynaptic neurons, GABAergic innervation from Golgi cells would induce Purkinje cells to express the $\alpha 6$ subunit in the central cerebellar mass. Nevertheless, Purkinje cells in the central cerebellar mass do not express the $\alpha 6$ or $\alpha 2$ subunits (Fig. 9C, D, G, H) (Takayama and Inoue, 2003). This result indicates that Golgi cell innervation does not induce expression of the $\alpha 6$ subunit in Purkinje cells, and suggests a postsynaptic self-autonomous mechanisms determine the types of subunits (Fig. 8).

5. Synaptic targeting and clustering of GABA_A receptor proteins

Synaptic targeting and clustering of GABA_A receptors are mediated by the interaction of the subunit proteins with the subsynaptic cytoskeleton, and it is thought that the diversity of subunits in the GABA_A receptors is important for subcellular localization (Barnes, 2000; Moss and Smart, 2001). Most single subunits are retained within the endoplasmic reticulum (Connolly *et al.*, 1996; Gorrie *et al.*, 1997; Taylor *et al.*, 2000). Specific subunits such as the $\gamma 2$ subunit can lead the assembled GABA_A receptors to the cell surface and synaptic site, clustering (Connolly *et al.*, 1999) in conjunction with a range of diverse anchoring protein molecules of such as gephyrin (Craig *et al.*, 1996; Essrich *et al.*, 1998; Kneussel *et al.*, 1999; Sassoe-Pognetto and Fritschy, 2000), GABA_A-receptor associated protein (GABARAP) (Wang *et al.*, 1999), microtubule-associated proteins, transporters, protein kinases and so on (Moss and Smart, 2001). Furthermore, anchoring proteins such as gephyrin and GABARAP are also involved in clustering of receptor proteins (Barnes, 2000; Moss and Smart, 2001).

6. Activity-dependent synaptic remodeling

Recent investigations revealed that GABAergic synapses are remodeled by the change in GABAergic input in auditory systems during the critical period (Kandler, 2004;

Kapfer et al., 2002; Kim and Kandler, 2003). Auditory experience guides subcellular localization of receptor proteins (Kapfer et al., 2002), induces functional and structural elimination of inhibitory synapses during the establishment of precise topography in the GABAergic/glycinergic pathway (Kim and Kandler, 2003), and mediates aural dominance bands in the inferior colliculus (Gabriele *et al.*, 2000). In the cerebellum, the above activity-dependent remodeling of GABAergic synapses has not yet been clarified, but could play roles in the formation and maturation of GABAergic synapses and networks.

7. Conclusion for this section

GABAergic axons determine their target neurons under the influence of environmental conditions. During the formation of GABAergic synapses, axon varicosities and growth cones which contains GABAergic vesicles give rise to presynapse. GABA-release could induce the maturation of postsynapse, including expression of the mature type receptor subunits, disappearance of immature type subunits, and targeting of subunit proteins. At the postsynapse, genetically determined subunits are expressed.

V Functions of GABAergic synapses in the cerebellum

The cerebellum is closely involved in learning motor skills (Ito, 1984; Llinas and Walton, 1990). GABAergic input might play important roles in cerebellar functions since GABAergic neurons regulate the neuronal activity of Purkinje cells and granule cells which organize the major stream of neural circuitry in the cerebellar cortex. Neuroanatomical analysis of the cerebellar local circuit suggests that GABAergic neurons play a role in lateral inhibition and negative feedback mechanisms on the Purkinje and granule cells. Furthermore, elimination of GABAergic input from the Golgi cells in the cerebellar granular layer caused overexcitation of granule cells resulting in severe ataxia during the acute phase (Watanabe *et*

al., 1998). Therefore, GABAergic input plays a role in the regulation of glutamatergic hyperexcitation and could be involved in motor coordination.

In addition, neuroimaging and biochemical studies indicate a dysfunction in the GABAergic system in the cerebellum of autistic patients (Dhossche, 2004; Fatemi et al., 2002). This result suggests that the GABAergic network in the cerebellum might be involved in not only motor function, but also higher brain functions.

VI Acknowledgements

I am grateful to Yoshihiko Ogawa and Hideki Nakamura at the Central Research Department of Hokkaido University School of Medicine for their technical assistance. I also thank Dr. Yoshiro Inoue and Dr. Takayuki Yoshida at the Department of Molecular Neuroanatomy Hokkaido University School of Medicine, Dr. Hitoshi Komuro at the Cleveland Clinic Foundation and Miss Shoko Kogawa, a student at Hokkaido University School of Medicine, for valuable discussions.

This work was supported by the Grants-in-Aid for scientific research from the Ministry of Education, Culture, Science, Sports and Technology of Japan, the Uehara Memorial Foundation and the Takeda Science Foundation.

References

- Abraham, J. H., and Schousboe, A. (1989). Effects of taurine on cell morphology and expression of low-affinity GABA receptors in cultured cerebellar granule cells. *Neurochem Res* **14**, 1031-8.
- Altman, J., and Bayer, S. A. (1997). "Development of the cerebellar system in relation to its evolution, structure, and functions." CPC Press, Boca Raton.
- Araki, T., Kiyama, H., and Tohyama, M. (1992). GABAA receptor subunit messenger RNAs show differential expression during cortical development in the rat brain. *Neuroscience* **51**, 583-91.
- Attwell, D., Barbour, B., and Szatkowski, M. (1993). Nonvesicular release of neurotransmitter. *Neuron* **11**, 401-7.
- Avoli, M. (2000). Epilepsy. In "GABA in the nervous system: the view at fifty years" (D. L. Martin and R. W. Olsen, Eds.), pp. 293-316. Lippincott Williams & Wilkins, Philadelphia.
- Barbin, G., Pollard, H., Gaiarsa, J. L., and Ben-Ari, Y. (1993). Involvement of GABAA receptors in the outgrowth of cultured hippocampal neurons. *Neurosci Lett* **152**, 150-4.
- Barker, J. L., Behar, T., Li, Y. X., Liu, Q. Y., Ma, W., Maric, D., Maric, I., Schaffner, A. E., Serafini, R., Smith, S. V., Somogyi, R., Vautrin, J. Y., Wen, X. L., and Xian, H. (1998). GABAergic cells and signals in CNS development. *Perspect Dev Neurobiol* **5**, 305-22.
- Barnes, E. M., Jr. (2000). Intracellular trafficking of GABA(A) receptors. *Life Sci* **66**, 1063-70.
- Baulac, S., Huberfeld, G., Gourfinkel-An, I., Mitropoulou, G., Beranger, A., Prud'homme, J. F., Baulac, M., Brice, A., Bruzzone, R., and LeGuern, E. (2001). First genetic evidence of GABA(A) receptor dysfunction in epilepsy: a mutation in the gamma2-subunit gene. *Nat Genet* **28**, 46-8.
- Behar, T., Schaffner, A., Laing, P., Hudson, L., Komoly, S., and Barker, J. (1993). Many spinal cord cells transiently express low molecular weight forms of glutamic acid decarboxylase during embryonic development. *Brain Res Dev Brain Res* **72**, 203-18.
- Behar, T. N., Li, Y. X., Tran, H. T., Ma, W., Dunlap, V., Scott, C., and Barker, J. L. (1996). GABA stimulates chemotaxis and chemokinesis of embryonic cortical neurons via calcium-dependent mechanisms. *J Neurosci* **16**, 1808-18.
- Behar, T. N., Schaffner, A. E., Colton, C. A., Somogyi, R., Olah, Z., Lehel, C., and Barker, J. L. (1994). GABA-induced chemokinesis and NGF-induced chemotaxis of embryonic spinal cord neurons. *J Neurosci* **14**, 29-38.

- Behar, T. N., Schaffner, A. E., Scott, C. A., Greene, C. L., and Barker, J. L. (2000). GABA receptor antagonists modulate postmitotic cell migration in slice cultures of embryonic rat cortex. *Cereb Cortex* **10**, 899-909.
- Behar, T. N., Schaffner, A. E., Tran, H. T., and Barker, J. L. (1995). GABA-induced motility of spinal neuroblasts develops along a ventrodorsal gradient and can be mimicked by agonists of GABAA and GABAB receptors. *J Neurosci Res* **42**, 97-108.
- Belhage, B., Hansen, G. H., Elster, L., and Schousboe, A. (1998). Effects of gamma-aminobutyric acid (GABA) on synaptogenesis and synaptic function. *Perspect Dev Neurobiol* **5**, 235-46.
- Belhage, B., Hansen, G. H., and Schousboe, A. (1993). Depolarization by K⁺ and glutamate activates different neurotransmitter release mechanisms in GABAergic neurons: vesicular versus non-vesicular release of GABA. *Neuroscience* **54**, 1019-34.
- Belhage, B., Meier, E., and Schousboe, A. (1986). GABA-agonists induce the formation of low-affinity GABA-receptors on cultured cerebellar granule cells via preexisting high affinity GABA receptors. *Neurochem Res* **11**, 599-606.
- Ben-Ari, Y. (2002). Excitatory actions of gaba during development: the nature of the nurture. *Nat Rev Neurosci* **3**, 728-39.
- Ben-Ari, Y., Khazipov, R., Leinekugel, X., Caillard, O., and Gaiarsa, J. L. (1997). GABAA, NMDA and AMPA receptors: a developmentally regulated 'menage a trois'. *Trends Neurosci* **20**, 523-9.
- Berninger, B., Marty, S., Zafra, F., da Penha Berzaghi, M., Thoenen, H., and Lindholm, D. (1995). GABAergic stimulation switches from enhancing to repressing BDNF expression in rat hippocampal neurons during maturation in vitro. *Development* **121**, 2327-35.
- Berry, N., Jobanputra, V., and Pal, H. (2003). Molecular genetics of schizophrenia: a critical review. *J Psychiatry Neurosci* **28**, 415-29.
- Blatt, G. J., Fitzgerald, C. M., Guptill, J. T., Booker, A. B., Kemper, T. L., and Bauman, M. L. (2001). Density and distribution of hippocampal neurotransmitter receptors in autism: an autoradiographic study. *J Autism Dev Disord* **31**, 537-43.
- Blum, B. P., and Mann, J. J. (2002). The GABAergic system in schizophrenia. *Int J Neuropsychopharmacol* **5**, 159-79.
- Borden, L. A. (1996). GABA transporter heterogeneity: pharmacology and cellular localization. *Neurochem Int* **29**, 335-56.
- Bormann, J. (1988). Electrophysiology of GABAA and GABAB receptor subtypes. *Trends*

Neurosci **11**, 112-6.

Bormann, J. (2000). The 'ABC' of GABA receptors. *Trends Pharmacol Sci* **21**, 16-9.

Bormann, J., and Feigenspan, A. (1995). GABAC receptors. *Trends Neurosci* **18**, 515-9.

Byne, W., Kemether, E., Jones, L., Haroutunian, V., and Davis, K. L. (1999). The neurochemistry of schizophrenia. In "Neurobiology of mental illness" (D. S. Charney, E. J. Nestler, and B. S. Bunney, Eds.), pp. 236-249. Oxford University Press, New York.

Cajal, S., Ramon y. (1911). *Histologie du Systeme Nerveux de l'Homme et des Vertebres*. Tome 2. Paris Maloine. Reprinted by Consejo Superior de Investigaciones Cientificas, Madrid, 1955.

Carlson, B. X., Belhage, B., Hansen, G. H., Elster, L., Olsen, R. W., and Schousboe, A. (1997). Expression of the GABA(A) receptor alpha6 subunit in cultured cerebellar granule cells is developmentally regulated by activation of GABA(A) receptors. *J Neurosci Res* **50**, 1053-62.

Carlson, B. X., Elster, L., and Schousboe, A. (1998). Pharmacological and functional implications of developmentally-regulated changes in GABA(A) receptor subunit expression in the cerebellum. *Eur J Pharmacol* **352**, 1-14.

Caruncho, H. J., Dopeso-Reyes, I. G., Loza, M. I., and Rodriguez, M. A. (2004). A GABA, reelin, and the neurodevelopmental hypothesis of schizophrenia. *Crit Rev Neurobiol* **16**, 25-32.

Caviness, V. S., Jr., and Rakic, P. (1978). Mechanisms of cortical development: a view from mutations in mice. *Annu Rev Neurosci* **1**, 297-326.

Chaudhry, F. A., Reimer, R. J., Bellocchio, E. E., Danbolt, N. C., Osen, K. K., Edwards, R. H., and Storm-Mathisen, J. (1998). The vesicular GABA transporter, VGAT, localizes to synaptic vesicles in sets of glycinergic as well as GABAergic neurons. *J Neurosci* **18**, 9733-50.

Cherubini, E., and Conti, F. (2001). Generating diversity at GABAergic synapses. *Trends Neurosci* **24**, 155-62.

Cherubini, E., Gaiarsa, J. L., and Ben-Ari, Y. (1991). GABA: an excitatory transmitter in early postnatal life. *Trends Neurosci* **14**, 515-9.

Connolly, C. N., Krishek, B. J., McDonald, B. J., Smart, T. G., and Moss, S. J. (1996). Assembly and cell surface expression of heteromeric and homomeric gamma-aminobutyric acid type A receptors. *J Biol Chem* **271**, 89-96.

Connolly, C. N., Uren, J. M., Thomas, P., Gorrie, G. H., Gibson, A., Smart, T. G., and Moss,

- S. J. (1999). Subcellular localization and endocytosis of homomeric gamma2 subunit splice variants of gamma-aminobutyric acid type A receptors. *Mol Cell Neurosci* **13**, 259-71.
- Connor, J. A., Tseng, H. Y., and Hockberger, P. E. (1987). Depolarization- and transmitter-induced changes in intracellular Ca²⁺ of rat cerebellar granule cells in explant cultures. *J Neurosci* **7**, 1384-400.
- Connors, B. W., Malenka, R. C., and Silva, L. R. (1988). Two inhibitory postsynaptic potentials, and GABAA and GABAB receptor-mediated responses in neocortex of rat and cat. *J Physiol* **406**, 443-68.
- Conti, F., Minelli, A., and Melone, M. (2004). GABA transporters in the mammalian cerebral cortex: localization, development and pathological implications. *Brain Res Brain Res Rev* **45**, 196-212.
- Conti, F., Zuccarello, L. V., Barbaresi, P., Minelli, A., Brecha, N. C., and Melone, M. (1999). Neuronal, glial, and epithelial localization of gamma-aminobutyric acid transporter 2, a high-affinity gamma-aminobutyric acid plasma membrane transporter, in the cerebral cortex and neighboring structures. *J Comp Neurol* **409**, 482-94.
- Cook, E. H., Jr., Lindgren, V., Leventhal, B. L., Courchesne, R., Lincoln, A., Shulman, C., Lord, C., and Courchesne, E. (1997). Autism or atypical autism in maternally but not paternally derived proximal 15q duplication. *Am J Hum Genet* **60**, 928-34.
- Costa, E., Davis, J. M., Dong, E., Grayson, D. R., Guidotti, A., Tremolizzo, L., and Veldic, M. (2004). A GABAergic cortical deficit dominates schizophrenia pathophysiology. *Crit Rev Neurobiol* **16**, 1-23.
- Craig, A. M., Banker, G., Chang, W., McGrath, M. E., and Serpinskaya, A. S. (1996). Clustering of gephyrin at GABAergic but not glutamatergic synapses in cultured rat hippocampal neurons. *J Neurosci* **16**, 3166-77.
- DeLorey, T. M., Handforth, A., Anagnostaras, S. G., Homanics, G. E., Minassian, B. A., Asatourian, A., Fanselow, M. S., Delgado-Escueta, A., Ellison, G. D., and Olsen, R. W. (1998). Mice lacking the beta3 subunit of the GABAA receptor have the epilepsy phenotype and many of the behavioral characteristics of Angelman syndrome. *J Neurosci* **18**, 8505-14.
- Dhossche, D., Applegate, H., Abraham, A., Maertens, P., Bland, L., Bencsath, A., and Martinez, J. (2002). Elevated plasma gamma-aminobutyric acid (GABA) levels in autistic youngsters: stimulus for a GABA hypothesis of autism. *Med Sci Monit* **8**, PR1-6.
- Dhossche, D. M. (2004). Autism as early expression of catatonia. *Med Sci Monit* **10**, RA31-9.
- Dumoulin, A., Rostaing, P., Bedet, C., Levi, S., Isambert, M. F., Henry, J. P., Triller, A., and

- Gasnier, B. (1999). Presence of the vesicular inhibitory amino acid transporter in GABAergic and glycinergic synaptic terminal boutons. *J Cell Sci* **112** (Pt 6), 811-23.
- Durkin, M. M., Smith, K. E., Borden, L. A., Weinshank, R. L., Branchek, T. A., and Gustafson, E. L. (1995). Localization of messenger RNAs encoding three GABA transporters in rat brain: an in situ hybridization study. *Brain Res Mol Brain Res* **33**, 7-21.
- Eilers, J., Plant, T. D., Marandi, N., and Konnerth, A. (2001). GABA-mediated Ca²⁺ signalling in developing rat cerebellar Purkinje neurones. *J Physiol* **536**, 429-37.
- Elster, L., Hansen, G. H., Belhage, B., Fritschy, J. M., Mohler, H., and Schousboe, A. (1995). Differential distribution of GABAA receptor subunits in soma and processes of cerebellar granule cells: effects of maturation and a GABA agonist. *Int J Dev Neurosci* **13**, 417-28.
- Essrich, C., Lorez, M., Benson, J. A., Fritschy, J. M., and Luscher, B. (1998). Postsynaptic clustering of major GABAA receptor subtypes requires the gamma 2 subunit and gephyrin. *Nat Neurosci* **1**, 563-71.
- Fagiolini, M., and Hensch, T. K. (2000). Inhibitory threshold for critical-period activation in primary visual cortex. *Nature* **404**, 183-6.
- Fairen, A., Alvarez-Bolado, G., DeDiego, I., and Smith-Fernandez, A. (1998). GABA-immunoreactive cells of the cortical primordium contribute to distinctly fated neuronal populations. *Perspect Dev Neurobiol* **5**, 159-73.
- Fatemi, S. H., Halt, A. R., Strydom, J. M., Kanodia, R., Schulz, S. C., and Realmuto, G. R. (2002). Glutamic acid decarboxylase 65 and 67 kDa proteins are reduced in autistic parietal and cerebellar cortices. *Biol Psychiatry* **52**, 805-10.
- Fon, E. A., and Edwards, R. H. (2001). Molecular mechanisms of neurotransmitter release. *Muscle Nerve* **24**, 581-601.
- Freeman, M. P., Freeman, S. A., and McElroy, S. L. (2002). The comorbidity of bipolar and anxiety disorders: prevalence, psychobiology, and treatment issues. *J Affect Disord* **68**, 1-23.
- Freund, T. F., and Gulyas, A. I. (1997). Inhibitory control of GABAergic interneurons in the hippocampus. *Can J Physiol Pharmacol* **75**, 479-87.
- Fritschy, J. M., and Mohler, H. (1995). GABAA-receptor heterogeneity in the adult rat brain: differential regional and cellular distribution of seven major subunits. *J Comp Neurol* **359**, 154-94.
- Fritschy, J. M., Paysan, J., Enna, A., and Mohler, H. (1994). Switch in the expression of rat GABAA-receptor subtypes during postnatal development: an immunohistochemical

- study. *J Neurosci* **14**, 5302-24.
- Frostholm, A., Zdilar, D., Chang, A., and Rotter, A. (1991). Stability of GABAA/benzodiazepine receptor alpha 1 subunit mRNA expression in reeler mouse cerebellar Purkinje cells during postnatal development. *Brain Res Dev Brain Res* **64**, 121-8.
- Gabriele, M. L., Brunso-Bechtold, J. K., and Henkel, C. K. (2000). Plasticity in the development of afferent patterns in the inferior colliculus of the rat after unilateral cochlear ablation. *J Neurosci* **20**, 6939-49.
- Gadea, A., and Lopez-Colome, A. M. (2001). Glial transporters for glutamate, glycine, and GABA: II. GABA transporters. *J Neurosci Res* **63**, 461-8.
- Gambarana, C., Pittman, R., and Siegel, R. E. (1990). Developmental expression of the GABAA receptor alpha 1 subunit mRNA in the rat brain. *J Neurobiol* **21**, 1169-79.
- Ganguly, K., Schinder, A. F., Wong, S. T., and Poo, M. (2001). GABA itself promotes the developmental switch of neuronal GABAergic responses from excitation to inhibition. *Cell* **105**, 521-32.
- Gao, B., and Fritschy, J. M. (1995). Cerebellar granule cells in vitro recapitulate the in vivo pattern of GABAA-receptor subunit expression. *Brain Res Dev Brain Res* **88**, 1-16.
- Gao, X. B., and van den Pol, A. N. (2000). GABA release from mouse axonal growth cones. *J Physiol* **523 Pt 3**, 629-37.
- Gorrie, G. H., Vallis, Y., Stephenson, A., Whitfield, J., Browning, B., Smart, T. G., and Moss, S. J. (1997). Assembly of GABAA receptors composed of alpha1 and beta2 subunits in both cultured neurons and fibroblasts. *J Neurosci* **17**, 6587-96.
- Haydar, T. F., Wang, F., Schwartz, M. L., and Rakic, P. (2000). Differential modulation of proliferation in the neocortical ventricular and subventricular zones. *J Neurosci* **20**, 5764-74.
- Hensch, T. K., Fagiolini, M., Mataga, N., Stryker, M. P., Baekkeskov, S., and Kash, S. F. (1998). Local GABA circuit control of experience-dependent plasticity in developing visual cortex. *Science* **282**, 1504-8.
- Ito, M. (1984). "The cerebellum and neural control." Raven Press, New York.
- Itouji, A., Sakai, N., Tanaka, C., and Saito, N. (1996). Neuronal and glial localization of two GABA transporters (GAT1 and GAT3) in the rat cerebellum. *Brain Res Mol Brain Res* **37**, 309-16.
- Jaffe, E. H., and Vaello, M. L. (1988). Two different release mechanisms of 3H-GABA induced by glutamate in the rat olfactory bulb. *P R Health Sci J* **7**, 99-101.

- Jakab, R. L., and Hamori, J. (1988). Quantitative morphology and synaptology of cerebellar glomeruli in the rat. *Anat Embryol* **179**, 81-8.
- Kanaka, C., Ohno, K., Okabe, A., Kuriyama, K., Itoh, T., Fukuda, A., and Sato, K. (2001). The differential expression patterns of messenger RNAs encoding K-Cl cotransporters (KCC1,2) and Na-K-2Cl cotransporter (NKCC1) in the rat nervous system. *Neuroscience* **104**, 933-46.
- Kandler, K. (2004). Activity-dependent organization of inhibitory circuits: lessons from the auditory system. *Curr Opin Neurobiol* **14**, 96-104.
- Kanner, B. I. (1994). Sodium-coupled neurotransmitter transport: structure, function and regulation. *J Exp Biol* **196**, 237-49.
- Kapfer, C., Seidl, A. H., Schweizer, H., and Grothe, B. (2002). Experience-dependent refinement of inhibitory inputs to auditory coincidence-detector neurons. *Nat Neurosci* **5**, 247-53.
- Kardos, J. (1999). Recent advances in GABA research. *Neurochem Int* **34**, 353-8.
- Kaupmann, K., Huggel, K., Heid, J., Flor, P. J., Bischoff, S., Mickel, S. J., McMaster, G., Angst, C., Bittiger, H., Froestl, W., and Bettler, B. (1997). Expression cloning of GABA(B) receptors uncovers similarity to metabotropic glutamate receptors. *Nature* **386**, 239-46.
- Kaupmann, K., Malitschek, B., Schuler, V., Heid, J., Froestl, W., Beck, P., Mosbacher, J., Bischoff, S., Kulik, A., Shigemoto, R., Karschin, A., and Bettler, B. (1998). GABA(B)-receptor subtypes assemble into functional heteromeric complexes. *Nature* **396**, 683-7.
- Kim, G., and Kandler, K. (2003). Elimination and strengthening of glycinergic/GABAergic connections during tonotopic map formation. *Nat Neurosci* **6**, 282-90.
- Kim, H. Y., Sapp, D. W., Olsen, R. W., and Tobin, A. J. (1993). GABA alters GABAA receptor mRNAs and increases ligand binding. *J Neurochem* **61**, 2334-7.
- Kneussel, M., Brandstatter, J. H., Laube, B., Stahl, S., Muller, U., and Betz, H. (1999). Loss of postsynaptic GABA(A) receptor clustering in gephyrin-deficient mice. *J Neurosci* **19**, 9289-97.
- Larramendi, L. H. M. (1969). Analysis of synaptogenesis in the cerebellum of the mouse. In "Neurobiology of cerebellar evolution and development" (R. Llinas, Ed.), pp. 783-843. Am Med Ass, Chicago.
- Lauder, J. M. (1993). Neurotransmitters as growth regulatory signals: role of receptors and second messengers. *Trends Neurosci* **16**, 233-40.

- Lauder, J. M., Han, V. K., Henderson, P., Verdoorn, T., and Towle, A. C. (1986). Prenatal ontogeny of the GABAergic system in the rat brain: an immunocytochemical study. *Neuroscience* **19**, 465-93.
- Laurie, D. J., Seeburg, P. H., and Wisden, W. (1992a). The distribution of 13 GABAA receptor subunit mRNAs in the rat brain. II. Olfactory bulb and cerebellum. *J Neurosci* **12**, 1063-76.
- Laurie, D. J., Wisden, W., and Seeburg, P. H. (1992b). The distribution of thirteen GABAA receptor subunit mRNAs in the rat brain. III. Embryonic and postnatal development. *J Neurosci* **12**, 4151-72.
- Lauritsen, M., Mors, O., Mortensen, P. B., and Ewald, H. (1999). Infantile autism and associated autosomal chromosome abnormalities: a register-based study and a literature survey. *J Child Psychol Psychiatry* **40**, 335-45.
- Leinekugel, X., Khalilov, I., McLean, H., Caillard, O., Gaiarsa, J. L., Ben-Ari, Y., and Khazipov, R. (1999). GABA is the principal fast-acting excitatory transmitter in the neonatal brain. *Adv Neurol* **79**, 189-201.
- Leinekugel, X., Tseeb, V., Ben-Ari, Y., and Bregestovski, P. (1995). Synaptic GABAA activation induces Ca²⁺ rise in pyramidal cells and interneurons from rat neonatal hippocampal slices. *J Physiol* **487** (Pt 2), 319-29.
- Levi, G., and Raiteri, M. (1993). Carrier-mediated release of neurotransmitters. *Trends Neurosci* **16**, 415-9.
- LeVine, H., 3rd. (1999). Structural features of heterotrimeric G-protein-coupled receptors and their modulatory proteins. *Mol Neurobiol* **19**, 111-49.
- Lewis, D. A., Volk, D. W., and Hashimoto, T. (2004). Selective alterations in prefrontal cortical GABA neurotransmission in schizophrenia: a novel target for the treatment of working memory dysfunction. *Psychopharmacology (Berl)* **174**, 143-50.
- Llinas, R., and Hillmann, D. E. (1969). Physiological and morphological organization of the cerebellar circuits in various vertebrates. In "Neurobiology of cerebellar evolution and development" (R. Llinas, Ed.), pp. 43-73. Am. Med. Ass, Chicago.
- Llinas, R., and Walton, K. D. (1990). Cerebellum. In "The synaptic organization of the Brain" (G. M. Shepherd, Ed.), pp. 214-245. Oxford University Press, Oxford.
- LoTurco, J. J., Owens, D. F., Heath, M. J., Davis, M. B., and Kriegstein, A. R. (1995). GABA and glutamate depolarize cortical progenitor cells and inhibit DNA synthesis. *Neuron* **15**, 1287-98.
- Lu, J., Karadsheh, M., and Delpire, E. (1999). Developmental regulation of the

- neuronal-specific isoform of K-Cl cotransporter KCC2 in postnatal rat brains. *J Neurobiol* **39**, 558-68.
- Luddens, H., Pritchett, D. B., Kohler, M., Killisch, I., Keinanen, K., Monyer, H., Sprengel, R., and Seeburg, P. H. (1990). Cerebellar GABAA receptor selective for a behavioural alcohol antagonist. *Nature* **346**, 648-51.
- Ma, W., and Barker, J. L. (1995). Complementary expressions of transcripts encoding GAD67 and GABAA receptor alpha 4, beta 1, and gamma 1 subunits in the proliferative zone of the embryonic rat central nervous system. *J Neurosci* **15**, 2547-60.
- Macdonald, R. L., and Olsen, R. W. (1994). GABAA receptor channels. *Annu Rev Neurosci* **17**, 569-602.
- Mariani, J., Crepel, F., Mikoshiba, K., Changeux, J. P., and Sotelo, C. (1977). Anatomical, physiological and biochemical studies of the cerebellum from Reeler mutant mouse. *Philos Trans R Soc Lond B Biol Sci* **281**, 1-28.
- Maric, D., Maric, I., Ma, W., Lahojuji, F., Somogyi, R., Wen, X., Sieghart, W., Fritschy, J. M., and Barker, J. L. (1997). Anatomical gradients in proliferation and differentiation of embryonic rat CNS accessed by buoyant density fractionation: alpha 3, beta 3 and gamma 2 GABAA receptor subunit co-expression by post-mitotic neocortical neurons correlates directly with cell buoyancy. *Eur J Neurosci* **9**, 507-22.
- Martin, D. L., and Rimvall, K. (1993). Regulation of gamma-aminobutyric acid synthesis in the brain. *J Neurochem* **60**, 395-407.
- Marty, S., Berninger, B., Carroll, P., and Thoenen, H. (1996). GABAergic stimulation regulates the phenotype of hippocampal interneurons through the regulation of brain-derived neurotrophic factor. *Neuron* **16**, 565-70.
- McBain, C. J., and Maccaferri, G. (1997). Synaptic plasticity in hippocampal interneurons? A commentary. *Can J Physiol Pharmacol* **75**, 488-94.
- McCarthy, M. M., Auger, A. P., and Perrot-Sinal, T. S. (2002). Getting excited about GABA and sex differences in the brain. *Trends Neurosci* **25**, 307-12.
- McIntire, S. L., Reimer, R. J., Schuske, K., Edwards, R. H., and Jorgensen, E. M. (1997). Identification and characterization of the vesicular GABA transporter. *Nature* **389**, 870-6.
- McKernan, R. M., and Whiting, P. J. (1996). Which GABAA-receptor subtypes really occur in the brain? *Trends Neurosci* **19**, 139-43.
- McLaughlin, B. J., Wood, J. G., Saito, K., Roberts, E., and Wu, J. Y. (1975). The fine structural localization of glutamate decarboxylase in developing axonal processes and presynaptic terminals of rodent cerebellum. *Brain Res* **85**, 355-71.

- Mehta, A. K., and Ticku, M. K. (1999). An update on GABAA receptors. *Brain Res Brain Res Rev* **29**, 196-217.
- Meier, E., Drejer, J., and Schousboe, A. (1984). GABA induces functionally active low-affinity GABA receptors on cultured cerebellar granule cells. *J Neurochem* **43**, 1737-44.
- Meier, E., and Jorgensen, O. S. (1986). Gamma-aminobutyric acid affects the developmental expression of neuron-associated proteins in cerebellar granule cell cultures. *J Neurochem* **46**, 1256-62.
- Meier, E., Jorgensen, O. S., and Schousboe, A. (1987). Effect of repeated treatment with a gamma-aminobutyric acid receptor agonist on postnatal neural development in rats. *J Neurochem* **49**, 1462-70.
- Mellor, J. R., Merlo, D., Jones, A., Wisden, W., and Randall, A. D. (1998). Mouse cerebellar granule cell differentiation: electrical activity regulates the GABAA receptor alpha 6 subunit gene. *J Neurosci* **18**, 2822-33.
- Mikawa, S., Wang, C., Shu, F., Wang, T., Fukuda, A., and Sato, K. (2002). Developmental changes in KCC1, KCC2 and NKCC1 mRNAs in the rat cerebellum. *Brain Res Dev Brain Res* **136**, 93-100.
- Millan, M. J. (2003). The neurobiology and control of anxious states. *Prog Neurobiol* **70**, 83-244.
- Mitchell, C. K., and Redburn, D. A. (1996). GABA and GABA-A receptors are maximally expressed in association with cone synaptogenesis in neonatal rabbit retina. *Brain Res Dev Brain Res* **95**, 63-71.
- Morara, S., Brecha, N. C., Marcotti, W., Provini, L., and Rosina, A. (1996). Neuronal and glial localization of the GABA transporter GAT-1 in the cerebellar cortex. *Neuroreport* **7**, 2993-6.
- Moss, S. J., and Smart, T. G. (2001). Constructing inhibitory synapses. *Nat Rev Neurosci* **2**, 240-50.
- Nayeem, N., Green, T. P., Martin, I. L., and Barnard, E. A. (1994). Quaternary structure of the native GABAA receptor determined by electron microscopic image analysis. *J Neurochem* **62**, 815-8.
- Nicoll, R. A. (1988). The coupling of neurotransmitter receptors to ion channels in the brain. *Science* **241**, 545-51.
- Nutt, D. J. (2001). Neurobiological mechanisms in generalized anxiety disorder. *J Clin Psychiatry* **62 Suppl 11**, 22-7; discussion 28.

- Nutt, D. J., Glue, P., and Lawson, C. (1990). The neurochemistry of anxiety: an update. *Prog Neuropsychopharmacol Biol Psychiatry* **14**, 737-52.
- Obrietan, K., and van den Pol, A. N. (1996). Growth cone calcium elevation by GABA. *J Comp Neurol* **372**, 167-75.
- Olsen, R. W., and Avoli, M. (1997). GABA and epileptogenesis. *Epilepsia* **38**, 399-407.
- Olsen, R. W., and Tobin, A. J. (1990). Molecular biology of GABAA receptors. *Faseb J* **4**, 1469-80.
- Owens, D. F., and Kriegstein, A. R. (2002). Is there more to GABA than synaptic inhibition? *Nat Rev Neurosci* **3**, 715-27.
- Palay, S. L., and Chan-Palay, V. (1974). "Cerebellar Cortex, Cytology and Organization." Springer, Berlin.
- Paulsen, O., and Moser, E. I. (1998). A model of hippocampal memory encoding and retrieval: GABAergic control of synaptic plasticity. *Trends Neurosci* **21**, 273-8.
- Perkins, K. L., and Wong, R. K. (1997). The depolarizing GABA response. *Can J Physiol Pharmacol* **75**, 516-9.
- Persohn, E., Malherbe, P., and Richards, J. G. (1992). Comparative molecular neuroanatomy of cloned GABAA receptor subunits in the rat CNS. *J Comp Neurol* **326**, 193-216.
- Phillis, J. W., Smith-Barbour, M., Perkins, L. M., and O'Regan, M. H. (1994). Characterization of glutamate, aspartate, and GABA release from ischemic rat cerebral cortex. *Brain Res Bull* **34**, 457-66.
- Pratt, J. A. (1992). The neuroanatomical basis of anxiety. *Pharmacol Ther* **55**, 149-81.
- Pritchett, D. B., Sontheimer, H., Shivers, B. D., Ymer, S., Kettenmann, H., Schofield, P. R., and Seeburg, P. H. (1989). Importance of a novel GABAA receptor subunit for benzodiazepine pharmacology. *Nature* **338**, 582-5.
- Raetzman, L. T., and Siegel, R. E. (1999). Immature granule neurons from cerebella of different ages exhibit distinct developmental potentials. *J Neurobiol* **38**, 559-70.
- Rakic, P. (1976). Synaptic specificity in the cerebellar cortex: study of anomalous circuits induced by single gene mutations in mice. *Cold Spring Harb Symp Quant Biol* **40**, 333-46.
- Reichling, D. B., Kyrozis, A., Wang, J., and MacDermott, A. B. (1994). Mechanisms of GABA and glycine depolarization-induced calcium transients in rat dorsal horn neurons. *J Physiol* **476**, 411-21.

- Reimer, R. J., Fon, E. A., and Edwards, R. H. (1998). Vesicular neurotransmitter transport and the presynaptic regulation of quantal size. *Curr Opin Neurobiol* **8**, 405-12.
- Ribak, C. E., Tong, W. M., and Brecha, N. C. (1996). Astrocytic processes compensate for the apparent lack of GABA transporters in the axon terminals of cerebellar Purkinje cells. *Anat Embryol (Berl)* **194**, 379-90.
- Rico, B., Xu, B., and Reichardt, L. F. (2002). TrkB receptor signaling is required for establishment of GABAergic synapses in the cerebellum. *Nat Neurosci* **5**, 225-33.
- Rohrbough, J., and Spitzer, N. C. (1996). Regulation of intracellular Cl⁻ levels by Na⁽⁺⁾-dependent Cl⁻ cotransport distinguishes depolarizing from hyperpolarizing GABA_A receptor-mediated responses in spinal neurons. *J Neurosci* **16**, 82-91.
- Rolf, L. H., Haarmann, F. Y., Grotemeyer, K. H., and Kehrer, H. (1993). Serotonin and amino acid content in platelets of autistic children. *Acta Psychiatr Scand* **87**, 312-6.
- Rosina, A., Morara, S., and Provini, L. (1999). GAT-1 developmental expression in the rat cerebellar cortex: basket and pinceau formation. *Neuroreport* **10**, 1613-8.
- Sassoe-Pognetto, M., and Fritschy, J. M. (2000). Mini-review: gephyrin, a major postsynaptic protein of GABAergic synapses. *Eur J Neurosci* **12**, 2205-10.
- Schousboe, A. (1999). Pharmacologic and therapeutic aspects of the developmentally regulated expression of GABA(A) and GABA(B) receptors: cerebellar granule cells as a model system. *Neurochem Int* **34**, 373-7.
- Serafini, R., Ma, W., Maric, D., Maric, I., Lahjouji, F., Sieghart, W., and Barker, J. L. (1998). Initially expressed early rat embryonic GABA(A) receptor Cl⁻ ion channels exhibit heterogeneous channel properties. *Eur J Neurosci* **10**, 1771-83.
- Sieghart, W. (1995). Structure and pharmacology of gamma-aminobutyric acidA receptor subtypes. *Pharmacol Rev* **47**, 181-234.
- Sieghart, W., Fuchs, K., Tretter, V., Ebert, V., Jechlinger, M., Hoyer, H., and Adamiker, D. (1999). Structure and subunit composition of GABA(A) receptors. *Neurochem Int* **34**, 379-85.
- Snead, O. C., 3rd, Depaulis, A., Vergnes, M., and Marescaux, C. (1999). Absence epilepsy: advances in experimental animal models. *Adv Neurol* **79**, 253-78.
- Sotelo, C., and Privat, A. (1978). Synaptic remodeling of the cerebellar circuitry in mutant mice and experimental cerebellar malformations. Study "in vivo" and "in vitro". *Acta Neuropathol (Berl)* **43**, 19-34.
- Spoerri, P. E. (1988). Neurotrophic effects of GABA in cultures of embryonic chick brain and

- retina. *Synapse* **2**, 11-22.
- Takamori, S., Riedel, D., and Jahn, R. (2000). Immunoisolation of GABA-specific synaptic vesicles defines a functionally distinct subset of synaptic vesicles. *J Neurosci* **20**, 4904-11.
- Takayama, C. (1994). Altered distribution of inhibitory synaptic terminals in reeler cerebellum with special reference to malposition of GABAergic neurons. *Neurosci Res* **20**, 239-50.
- Takayama, C., and Inoue, Y. (2003). Normal formation of the postsynaptic elements of GABAergic synapses in the reeler cerebellum. *Brain Res Dev Brain Res* **145**, 197-211.
- Takayama, C., and Inoue, Y. (2004a). Extrasynaptic localization of GABA in the developing mouse cerebellum. *Neurosci Res* **50**, 447-58.
- Takayama, C., and Inoue, Y. (2004b). Morphological development and maturation of the GABAergic synapses in the mouse cerebellar granular layer. *Brain Res Dev Brain Res* **150**, 175-188.
- Takayama, C., and Inoue, Y. (2004c). Morphological development and maturation of the GABAergic synapses in the mouse cerebellar granular layer. *Brain Res Dev Brain Res* **150**, 177-90.
- Takayama, C., and Inoue, Y. (2004d). Transient expression of GABA(A) receptor alpha2 and alpha3 subunits in differentiating cerebellar neurons. *Brain Res Dev Brain Res* **148**, 169-77.
- Taylor, J., Docherty, M., and Gordon-Weeks, P. R. (1990). GABAergic growth cones: release of endogenous gamma-aminobutyric acid precedes the expression of synaptic vesicle antigens. *J Neurochem* **54**, 1689-99.
- Taylor, J., and Gordon-Weeks, P. R. (1991). Calcium-independent gamma-aminobutyric acid release from growth cones: role of gamma-aminobutyric acid transport. *J Neurochem* **56**, 273-80.
- Taylor, P. M., Connolly, C. N., Kittler, J. T., Gorrie, G. H., Hosie, A., Smart, T. G., and Moss, S. J. (2000). Identification of residues within GABA(A) receptor alpha subunits that mediate specific assembly with receptor beta subunits. *J Neurosci* **20**, 1297-306.
- Tia, S., Wang, J. F., Kotchabhakdi, N., and Vicini, S. (1996). Developmental changes of inhibitory synaptic currents in cerebellar granule neurons: role of GABA(A) receptor alpha 6 subunit. *J Neurosci* **16**, 3630-40.
- Tretter, V., Ehya, N., Fuchs, K., and Sieghart, W. (1997). Stoichiometry and assembly of a recombinant GABAA receptor subtype. *J Neurosci* **17**, 2728-37.

- Turek, F. W., and Van Reeth, O. (1988). Altering the mammalian circadian clock with the short-acting benzodiazepine, triazolam. *Trends Neurosci* **11**, 535-41.
- Van Eden, C. G., Mrzljak, L., Voorn, P., and Uylings, H. B. (1989). Prenatal development of GABA-ergic neurons in the neocortex of the rat. *J Comp Neurol* **289**, 213-27.
- Varju, P., Katarova, Z., Madarasz, E., and Szabo, G. (2001). GABA signalling during development: new data and old questions. *Cell Tissue Res* **305**, 239-46.
- Vaughn, J. E. (1989). Fine structure of synaptogenesis in the vertebrate central nervous system. *Synapse* **3**, 255-85.
- Vicario-Abejon, C., Collin, C., McKay, R. D., and Segal, M. (1998). Neurotrophins induce formation of functional excitatory and inhibitory synapses between cultured hippocampal neurons. *J Neurosci* **18**, 7256-71.
- Vicini, S. (1999). New perspectives in the functional role of GABA(A) channel heterogeneity. *Mol Neurobiol* **19**, 97-110.
- Wagner, S., Castel, M., Gainer, H., and Yarom, Y. (1997). GABA in the mammalian suprachiasmatic nucleus and its role in diurnal rhythmicity. *Nature* **387**, 598-603.
- Wallace, R. H., Marini, C., Petrou, S., Harkin, L. A., Bowser, D. N., Panchal, R. G., Williams, D. A., Sutherland, G. R., Mulley, J. C., Scheffer, I. E., and Berkovic, S. F. (2001). Mutant GABA(A) receptor gamma2-subunit in childhood absence epilepsy and febrile seizures. *Nat Genet* **28**, 49-52.
- Wang, H., Bedford, F. K., Brandon, N. J., Moss, S. J., and Olsen, R. W. (1999). GABA(A)-receptor-associated protein links GABA(A) receptors and the cytoskeleton. *Nature* **397**, 69-72.
- Wassef, A., Baker, J., and Kochan, L. D. (2003). GABA and schizophrenia: a review of basic science and clinical studies. *J Clin Psychopharmacol* **23**, 601-40.
- Watanabe, D., Inokawa, H., Hashimoto, K., Suzuki, N., Kano, M., Shigemoto, R., Hirano, T., Toyama, K., Kaneko, S., Yokoi, M., Moriyoshi, K., Suzuki, M., Kobayashi, K., Nagatsu, T., Kreitman, R. J., Pastan, I., and Nakanishi, S. (1998). Ablation of cerebellar Golgi cells disrupts synaptic integration involving GABA inhibition and NMDA receptor activation in motor coordination. *Cell* **95**, 17-27.
- Williams, J. R., Sharp, J. W., Kumari, V. G., Wilson, M., and Payne, J. A. (1999). The neuron-specific K-Cl cotransporter, KCC2. Antibody development and initial characterization of the protein. *J Biol Chem* **274**, 12656-64.
- Wilson, L., Sotelo, C., and Caviness, V. S., Jr. (1981). Heterologous synapses upon Purkinje cells in the cerebellum of the Reeler mutant mouse: an experimental light and electron microscopic study. *Brain Res* **213**, 63-82.

- Wisden, W., Korpi, E. R., and Bahn, S. (1996). The cerebellum: a model system for studying GABAA receptor diversity. *Neuropharmacology* **35**, 1139-60.
- Wisden, W., Laurie, D. J., Monyer, H., and Seeburg, P. H. (1992). The distribution of 13 GABAA receptor subunit mRNAs in the rat brain. I. Telencephalon, diencephalon, mesencephalon. *J Neurosci* **12**, 1040-62.
- Wolff, J. R., Joo, F., and Dames, W. (1978). Plasticity in dendrites shown by continuous GABA administration in superior cervical ganglion of adult rat. *Nature* **274**, 72-4.
- Wolff, J. R., Joo, F., and Kasa, P. (1993). Modulation by GABA of neuroplasticity in the central and peripheral nervous system. *Neurochem Res* **18**, 453-61.
- Yuste, R., and Katz, L. C. (1991). Control of postsynaptic Ca²⁺ influx in developing neocortex by excitatory and inhibitory neurotransmitters. *Neuron* **6**, 333-44.

Figure Legends

Figure1 GABAergic neurons (A) and the GABAergic local circuit in the cerebellar cortex

(B).

(A) Immunohistochemistry for GABA in the adult mouse cerebellar cortex.

Cell bodies and axon terminals of stellate (St) and basket (Ba) cells are labeled in the molecular (Mo) and Purkinje cell (Pu) layers. Golgi cell bodies (Go) and their axon terminals (white arrows) are also stained in the granular layer (Gr). However, cell bodies (asterisks) and dendrites of Purkinje cells are negative.

(B) Schematic illustration of the local neural circuit and GABA_A receptor α subunit expression in the adult cerebellar cortex.

Abbreviations and symbols. St: stellate cell, Ba: basket cell, asterisk: Purkinje cell body, Go: Golgi cell, white arrow: GABA-positive rings in the synaptic glomerulus, Mo: molecular layer, Pu: Purkinje cell layer, Gr: granular layer, PF: parallel fiber, $\alpha 1$: GABA_A receptor $\alpha 1$ subunit, G: granule cell, $\alpha 1/6$: GABA_A receptor $\alpha 1$ and $\alpha 6$ subunits, MF: mossy fiber, CF: climbing fiber, IO: inferior olivary nucleus, Nu: deep cerebellar nucleus, PN/SC: pontine nucleus and spinal cord, black arrow: GABAergic innervation and synapse, gray circle: GABAergic neuron, dotted circle: excitatory neuron.

Bar: 10 μ m

Figure2 Schematic illustration of GABAergic transmission in the mature GABAergic synapse

GABA is synthesized from glutamate by glutamic acid decarboxylase (GAD), and is loaded into vesicles by the vesicular GABA transporter (VGAT). GABA is released by the fusion of vesicles with the presynaptic membrane at the nerve terminals, and activates GABA receptors (GABAR) at the postsynaptic membrane. In the adult synapses, activation of GABA_A

receptors mediates hyperpolarization of postsynaptic membrane potential (IPSP) by the influx of chloride ion (Cl⁻). GABAergic signals are terminated by uptake and reuptake of neurotransmitter into nerve terminals or uptake into surrounding glia by the plasma membrane GABA transporters (GAT).

Abbreviations GAD: glutamic acid decarboxylase, VGAT: vesicular GABA transporter, GAT: (plasma membrane) GABA transporter, GABAR: GABA receptor, IPSP: inhibitory postsynaptic potential.

Figure3 Immunohistochemical localization of GAT-1 (A, B) and GAT-3 (C, D) in the adult mouse cerebellar cortex

(A and B) GAT-1-immunolabeling is localized at the axon terminals of GABAergic neurons in the molecular (Mo), Purkinje cell, and granular (Gr) layers. In the granular layer, GAT-1-immunolabeling exhibits ring-shaped profiles (white arrowheads) at the synaptic glomeruli in a light micrograph (A). An electron micrograph of the granular layer shows that the immunolabeling is detected at the axon terminals, which contain flat vesicles and form symmetric synapses (black arrows) with granule cell dendrites (Gd) (B). In addition, weak immunolabeling is also observed at the astrocytes (black arrows).

(C and D) GAT-3 immunolabeling is detected in the neuropil of Purkinje cell and granular (Gr) layers in the light micrograph (C), and localize at the processes of astrocytes (black arrows) in the electron micrograph (D).

Abbreviations and symbols: Mo: molecular layer, Gr: granular layer, asterisk: Purkinje cell body, white arrowhead: synaptic glomerulus, Mf: mossy fiber terminal, Gd: granule cell dendrite, black arrowhead: symmetric synapse, black arrows: immunolabeling in the process of astrocytes.

Bar in the EM: 1 μ m

Figure4 Immunohistochemical localization of GABA (A, D), VGAT (B, E) and GABA_A receptor α 1 subunit (C, F) in the cerebellar cortex at postnatal day 7 (P7) (A-C) and P21 (D-F).

At P7, GABA is localized throughout the GABAergic neurons (A). VGAT, a marker of GABAergic vesicles, is confined to the axon varicosities (B). VGAT is often localized at the axons where mature GABAergic synapses, labeled by the immunohistochemistry for GABA_A receptor α 1 subunit (C), are not formed in the granular layer (Gr). In contrast, at P21, the majority of GABA is confined to the terminals (D) where VGAT (E) and α 1 subunit (F) are localized.

Abbreviations and symbols, Mo: molecular layer, Gr: granular layer, asterisk: Purkinje cell body.

Figure5 Electron microscopic localization of GABA (A) and VGAT (B, C) in the immature cerebellum at P5 and the extrasynaptic GABA secretion system (D).

(A-C) Electron micrographs of the immunohistochemistry for GABA (A) and VGAT (B, C) in the cerebellum at P5. GABA is distributed throughout the dendrites (A), whereas VGAT is detected at the vesicles (arrowheads) in the growth cone (GC) and axon varicosities (Va).

(D) Schematic illustration of the extrasynaptic GABA-release system. Before synapse formation, GABA could be released in two ways: diacrine of cytosolic GABA by plasma membrane GABA transporters (GATs) and exocytosis of GABAergic vesicles. GABA is diffused in the extracellular space and activates GABA receptors (GABAR) on the neighboring neurons.

Abbreviations Pu: Purkinje cell dendrite, Pf: parallel fiber, asterisk: asymmetric synapse, GC: growth cone, v: vacuole, Ax: axon, Va: axon varicosity, arrowhead: synaptic vesicle, GAD: glutamic acid decarboxylase, VGAT: vesicular GABA transporter, GAT: (plasma membrane) GABA transporter, GABAR: GABA receptor

Bar in the EM=1 μ m

Figure6 Developmental expression of GAT-1 (A-E) and GAT-3 (F, G) in the cerebellar cortex.

(A-E) Immunohistochemical localization of GAT-1 at P5 (A-C) and P10 (D, E). GAT-1 immunolabeling appears at P5 in the granular layer (Gr) (A), and is localized at the axons and varicosities containing vesicles (V) (B, C). At P10, the immunolabeling is also detected in the molecular (Mo) and Purkinje cell (asterisks) layers and is localized at the axon terminals of stellate cells, which often form symmetric synapses (arrowheads).

(F and G) Immunohistochemical localization of GAT3 in the cerebellum at P10.

GAT3-immunolabeling (white arrows) appears at P10 in the deep part of the granular layer (Gr) (F), and is localized at the processes of astrocytes (black arrows).

Abbreviations and symbols, Mo: molecular layer, Gr: granular layer, asterisk: Purkinje cell body, white arrow: GAT-3 immunolabeling in the granular layer, V: GABAergic vesicle, arrowhead: synapse and synapse-like structure, black arrow: GAT3-positive process of astrocytes, Mf: mossy fiber, Gd: granule cell dendrite.

Bar in the EM: 0.5 μ m

Figure7 Developmental changes in GABA-release (A, B) and uptake (C-E) mechanisms in the mouse cerebellum.

(A and B) Schematic illustrations of developmental changes in the GABA release system.

In the developing cerebellum, GABA is localized throughout the GABAergic neurons and is released by exocytosis (V) from axon varicosities (circle) and growth cones (triangles) (A). In contrast, GABA disappears from dendrites and axons in the mature brain, and is exclusively released synaptically (B).

(C-E) Schematic illustrations of developmental changes in the GABA-uptake and reuptake system in the mouse cerebellar cortex. Before synapse formation, GABA is released from axon varicosities and growth cones of GABAergic neurons and disappears by diffusion (C). During synaptogenesis, GAT-1 mediates the reuptake from the extracellular space into the axon and presynapses (D). In the mature cerebellum, GABA is removed from synaptic clefts into the presynapse by GAT-1 and astrocytes by GAT-3 (E).

Abbreviations V: vesicular secretion (exocytosis), GABAR: GABA receptor

Figure8 Schematic illustrations of the developmental changes in GABA actions.

A) In the developing CNS, opening of GABA_A receptors (GABAR) generates efflux of chloride ion (Cl⁻) and depolarization of membrane potential, since the intracellular chloride concentration, [Cl⁻]_i, is relatively high due to the dominant action of sodium-potassium-chloride co-transporter 1 (NKCC1). GABA-inducing depolarization activates the voltage dependent calcium channel (VDCC) and mediates calcium influx (Ca⁺⁺).

B) In the mature CNS, GABA mediates influx of chloride ion (Cl⁻), since potassium-chloride co-transporter 2 (KCC2) lowers the intracellular chloride concentration. Influx of chloride ion mediates hyperpolarization of membrane potential.

Figure9 Schematic illustrations of the abnormalities in the GABAergic inputs in the reeler

cerebellum.

In the central cerebellar mass of the reeler cerebellum, Purkinje cells (Pu) receive inhibitory inputs (arrows) from Golgi cells (Go) instead of stellate (st) and basket (ba) cells. GABA_A receptors containing only the $\alpha 1$ subunit ($\alpha 1$), but not the remaining five α subunits, are localized at the GABAergic synapses on the Purkinje cells, although Golgi cells innervate them. In addition, GABAergic input from the Purkinje cell axon collaterals increased markedly.

Abbreviations; Pu: Purkinje cell, Go: Golgi cell, St: stellate cell, Ba: basket cell, Nu: cerebellar nucleus

Figure 10 Distinct expression of the GABA_A receptor $\alpha 1$ (A, B), $\alpha 2$ (C, D), $\alpha 3$ (E, F) and $\alpha 6$ (G, H) subunits in the normal (A, C, E, G), and reeler (B, D, F, H) cerebella.

The specific expression of α subunit mRNAs in each neuronal type was preserved in the reeler cerebellum. Furthermore, abnormal expression of α subunits was not detected, although GABAergic networks were altered and neuronal maturation is severely disturbed.

Abbreviations: IC: inferior colliculus, Mo: molecular layer, Pu: Purkinje cell layer, Gr: granular layer, Nu: cerebellar nucleus, WM: white matter, asterisks: central cerebellar mass beneath the granular layer, CM: central cerebella mass under the white matter.

Table I Changes in expression of the predominant α subunits of the GABA_A receptors in the cerebellar cortical neurons

	Proliferating stage	Migrating and Differentiating stage	Matured stage
Purkinje cells	negative	$\alpha 3$ subunit	$\alpha 1$ subunit
Granule cells	negative	$\alpha 2$ subunit	$\alpha 1$ and $\alpha 6$ subunits

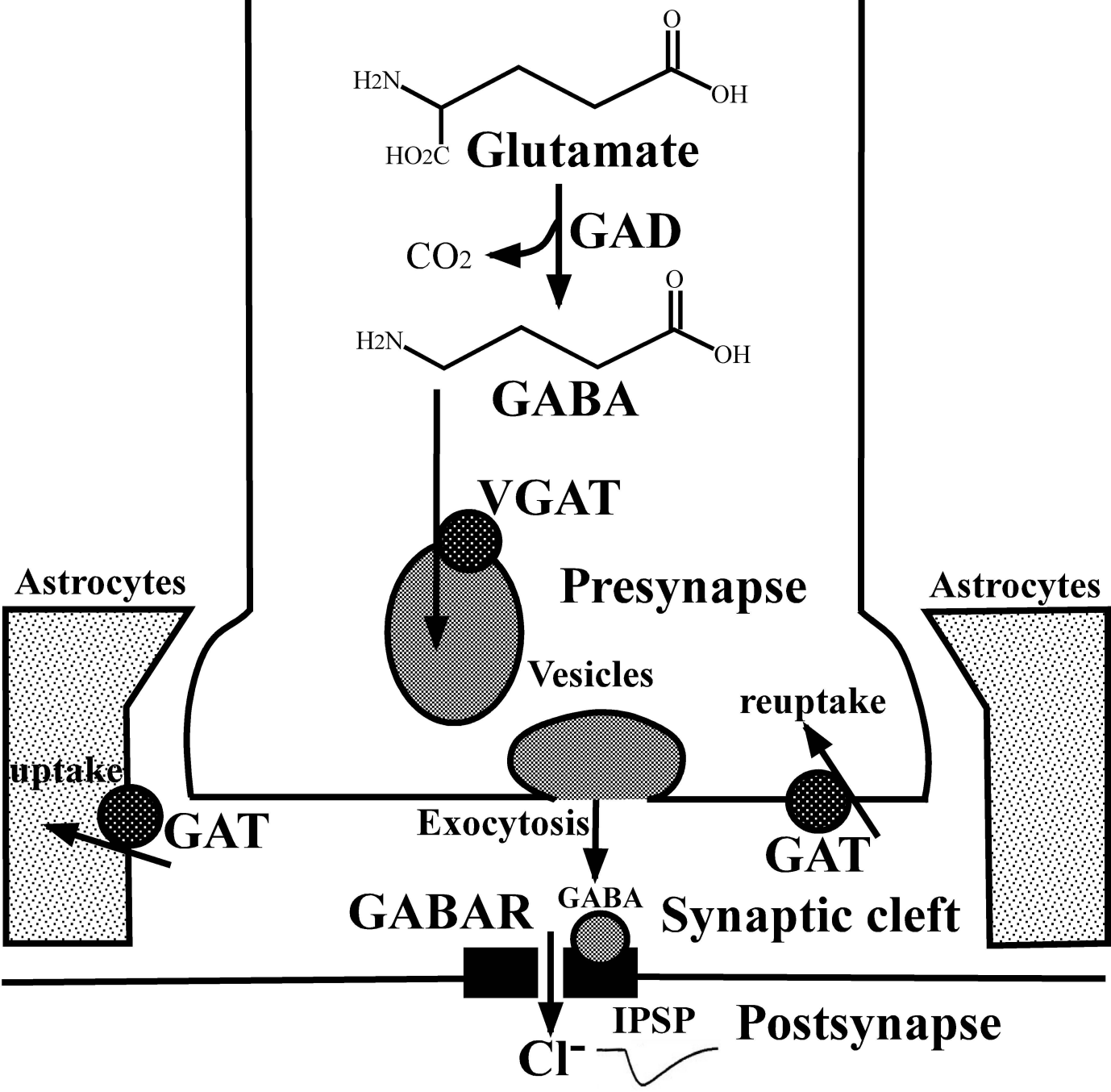

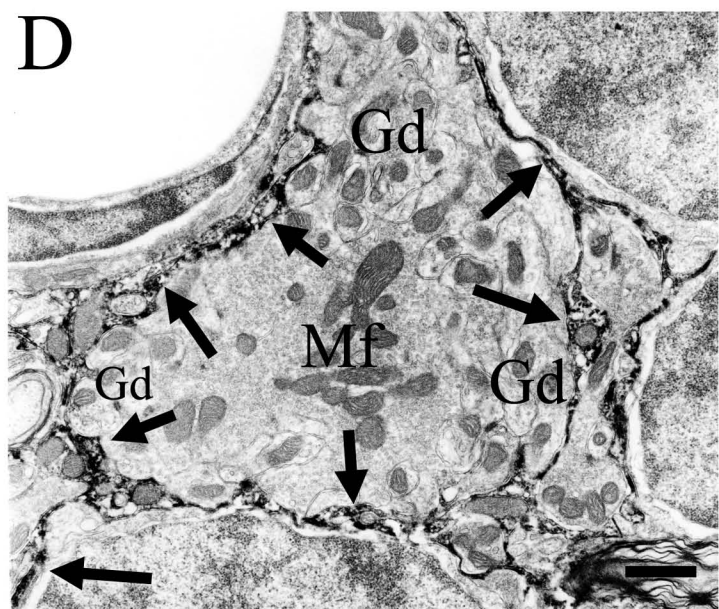
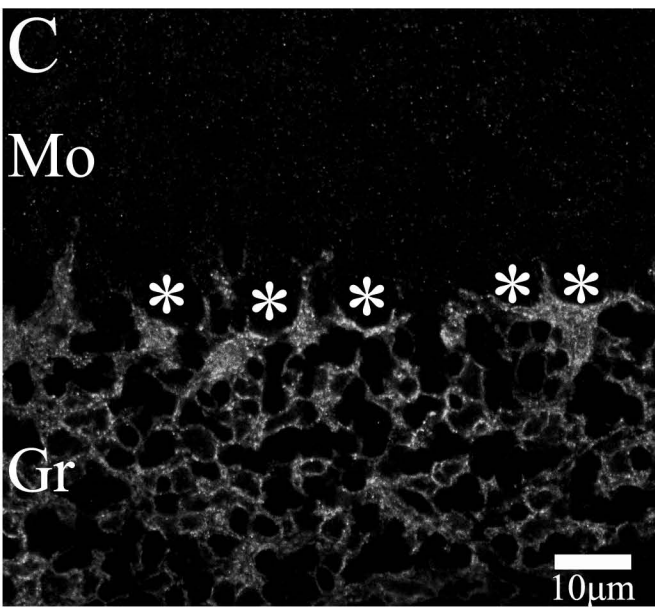
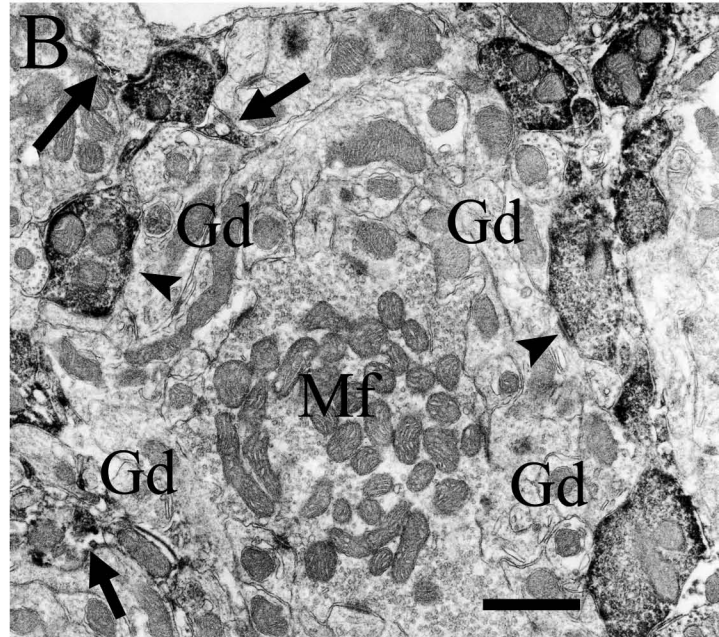

GABA

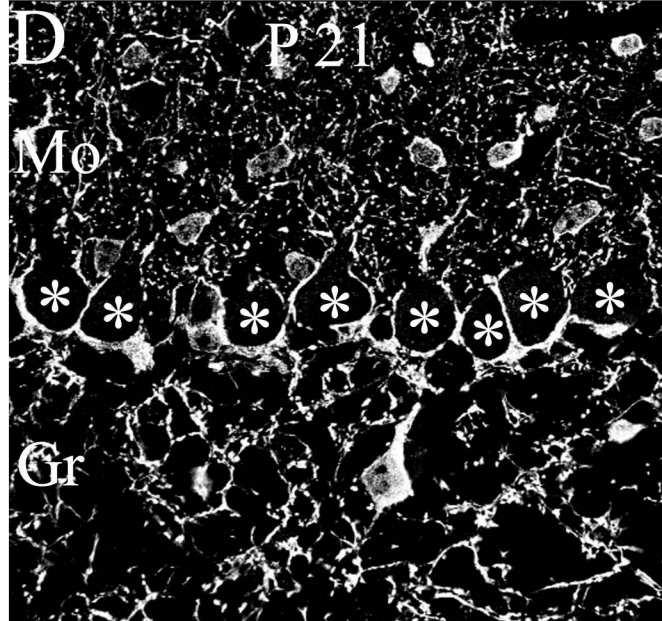
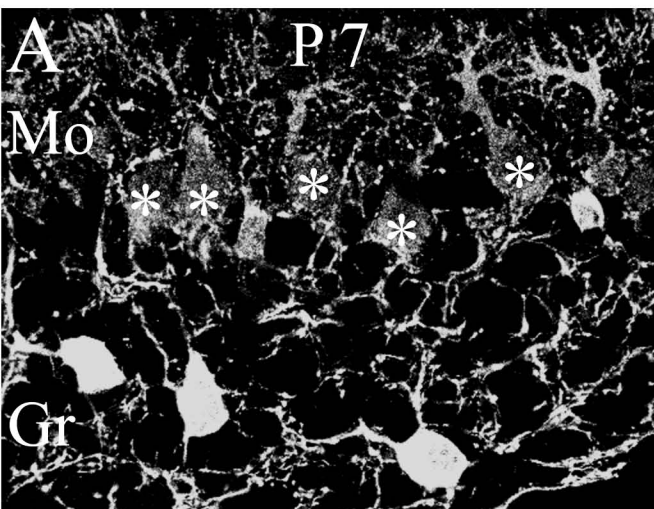

VGAT

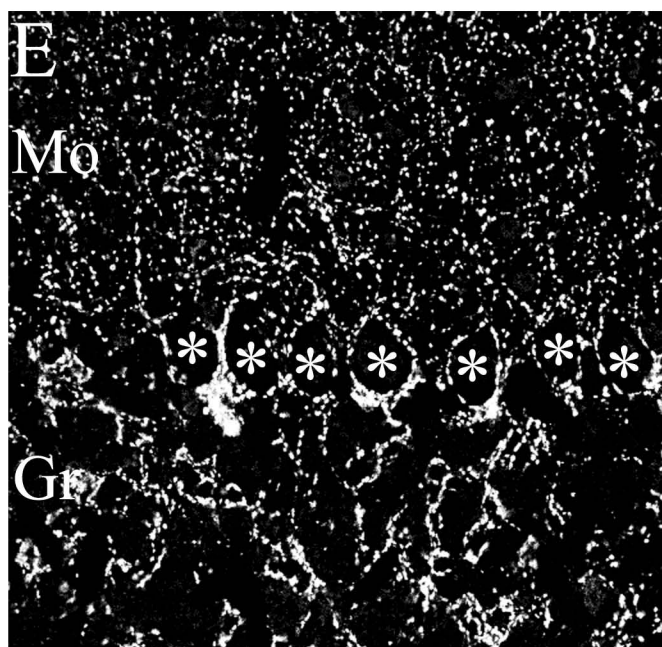
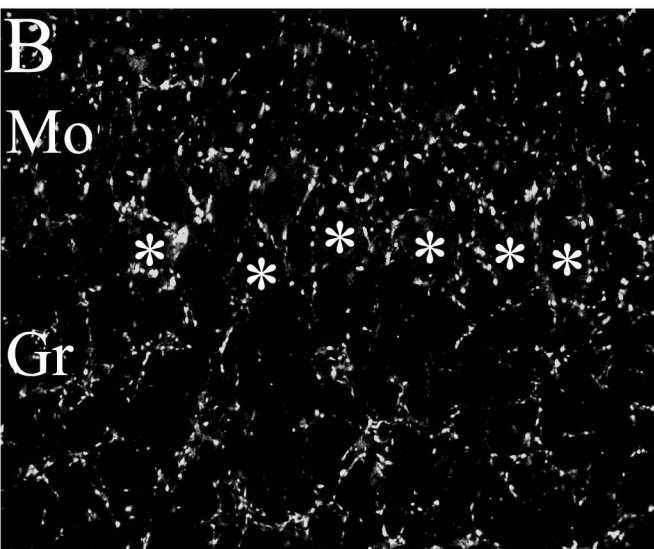

GABAR $\alpha 1$

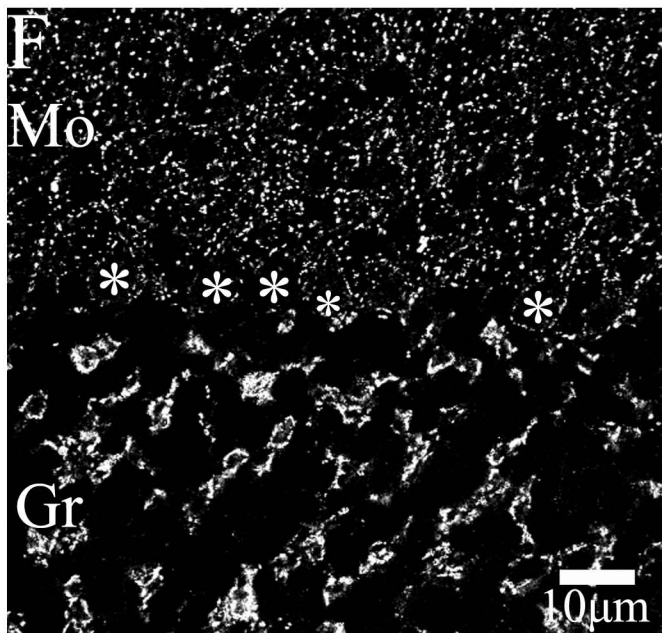
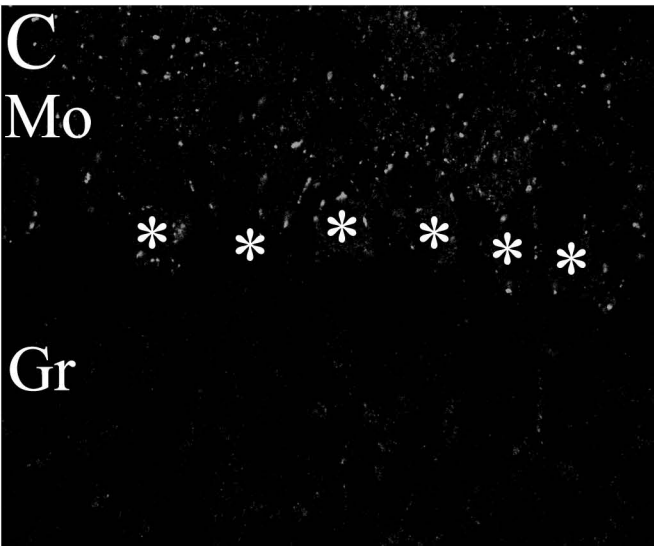

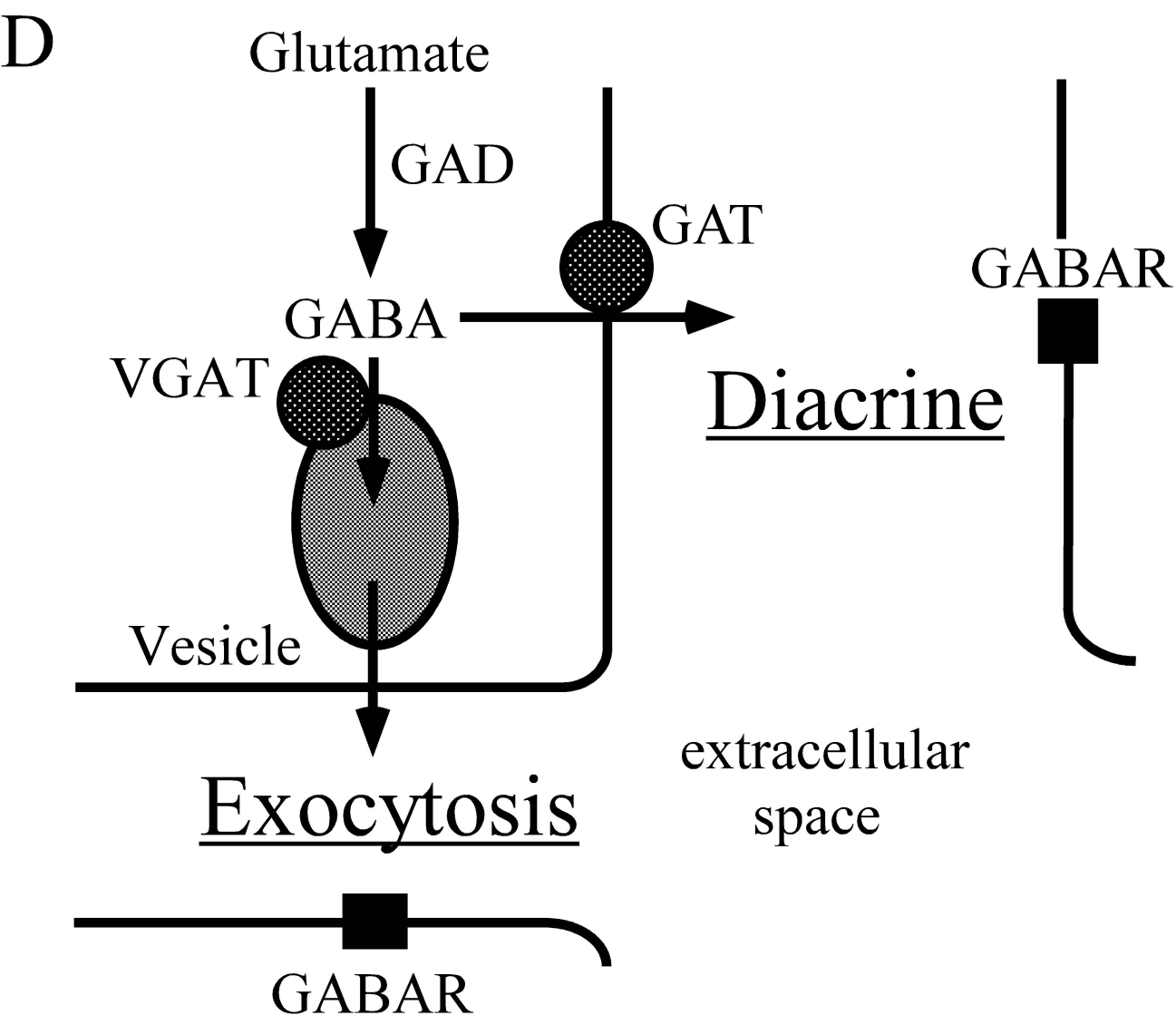
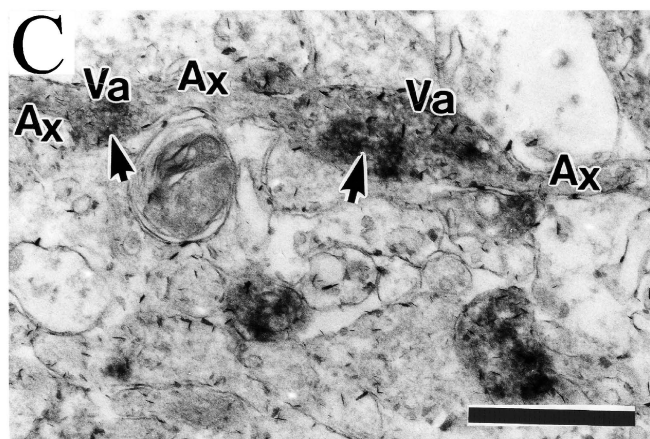
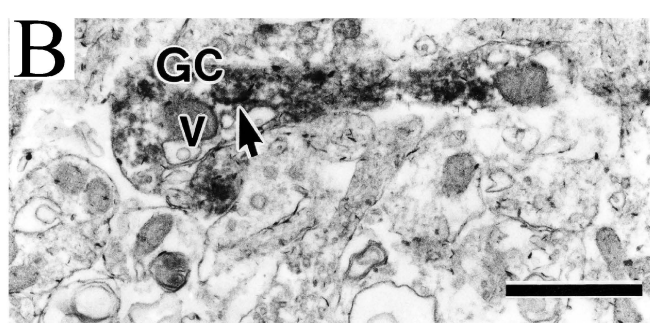
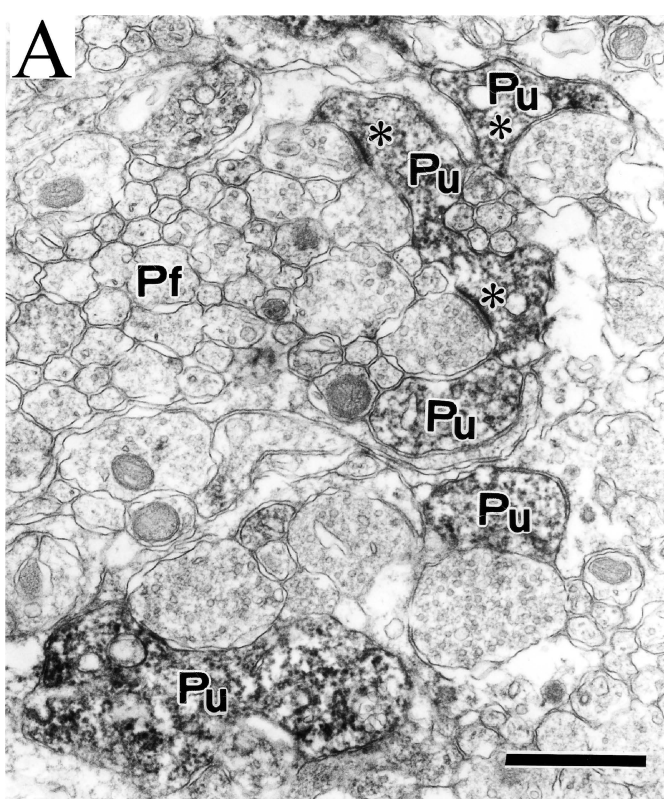

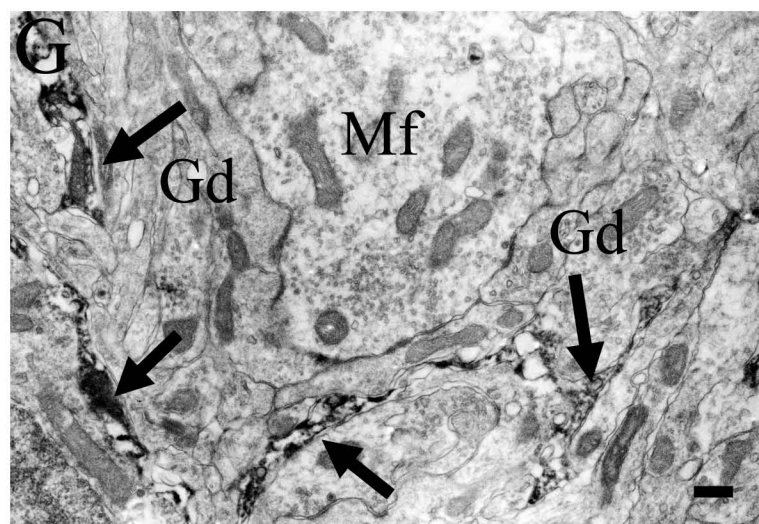
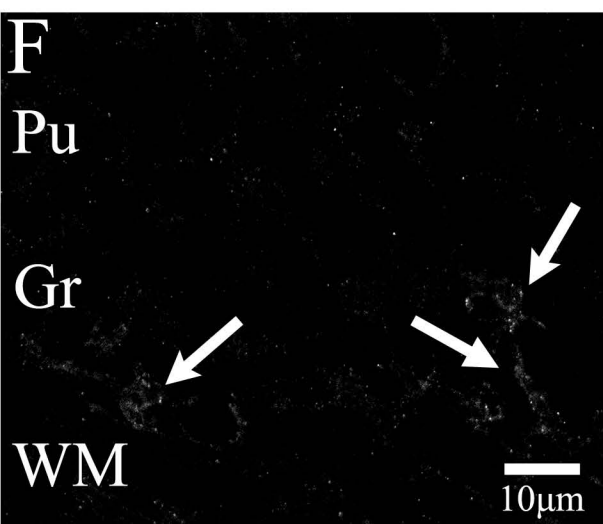
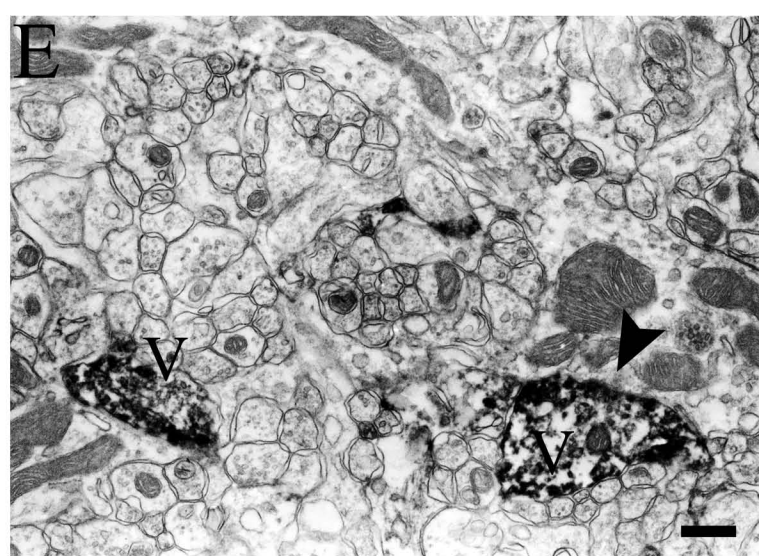
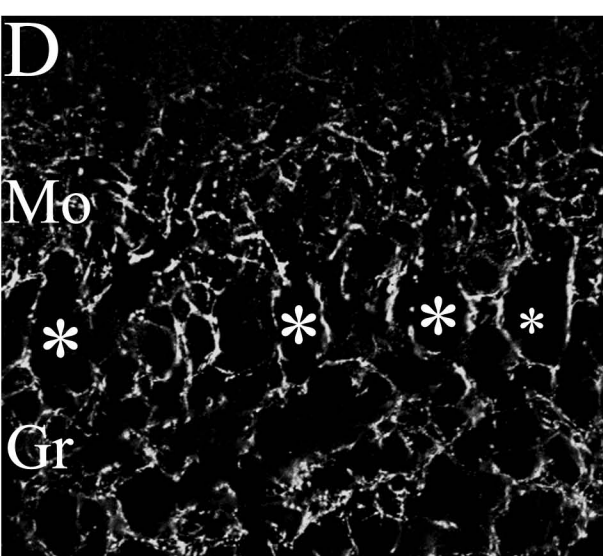
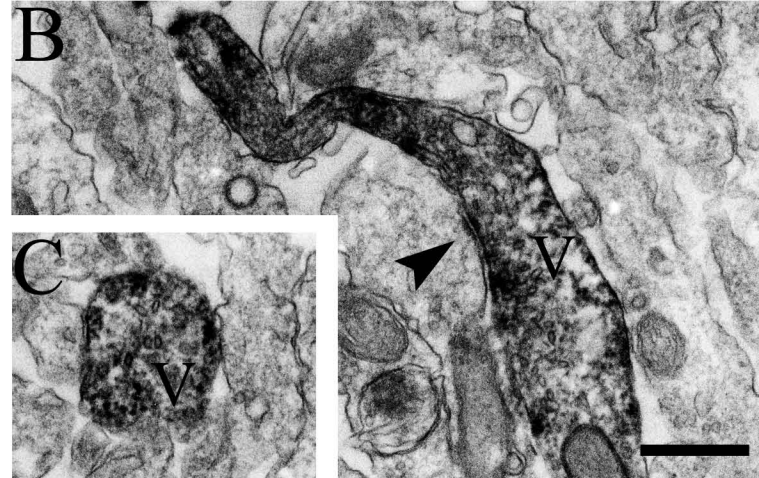

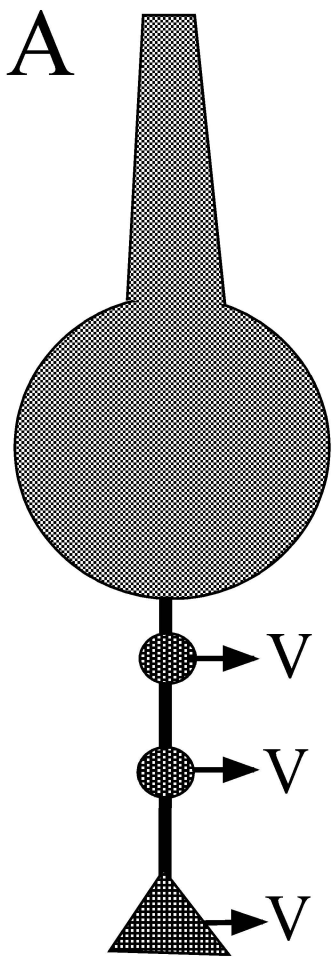

Developing stage

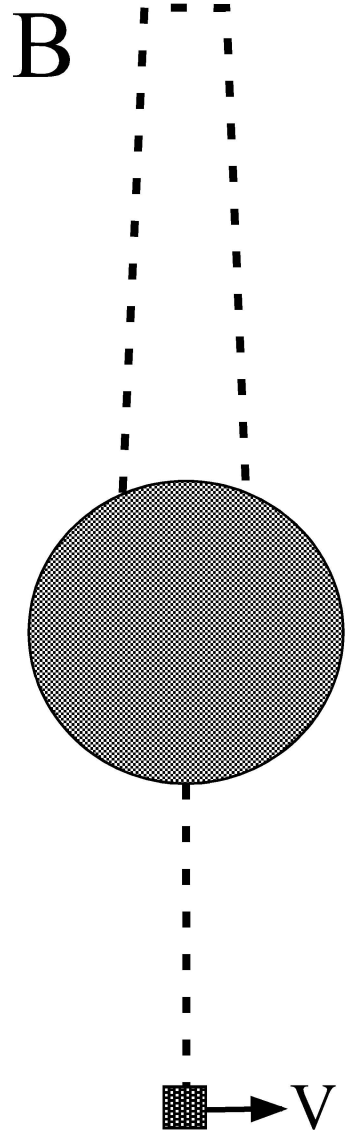

Mature stage

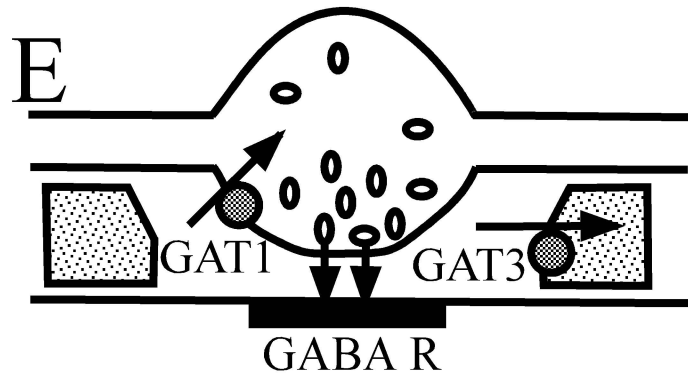
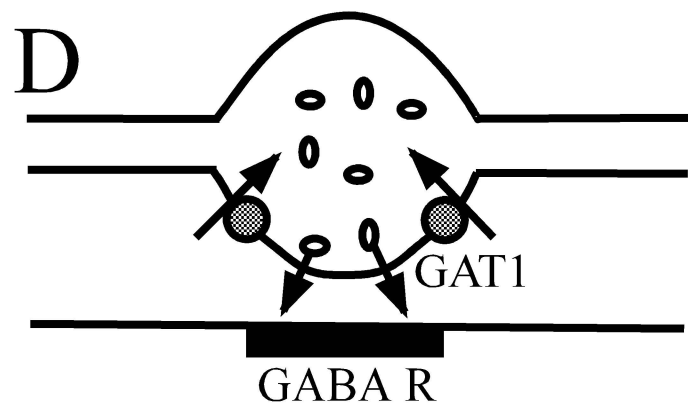
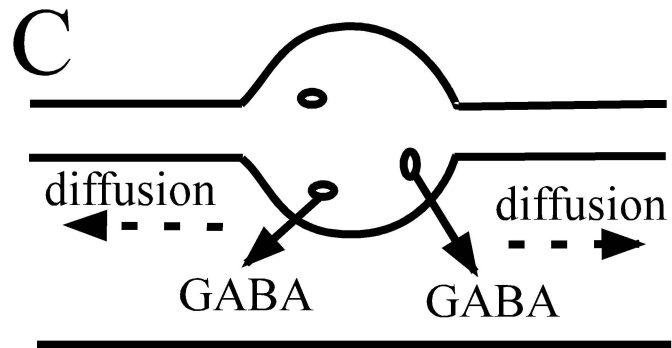

A Depolarization

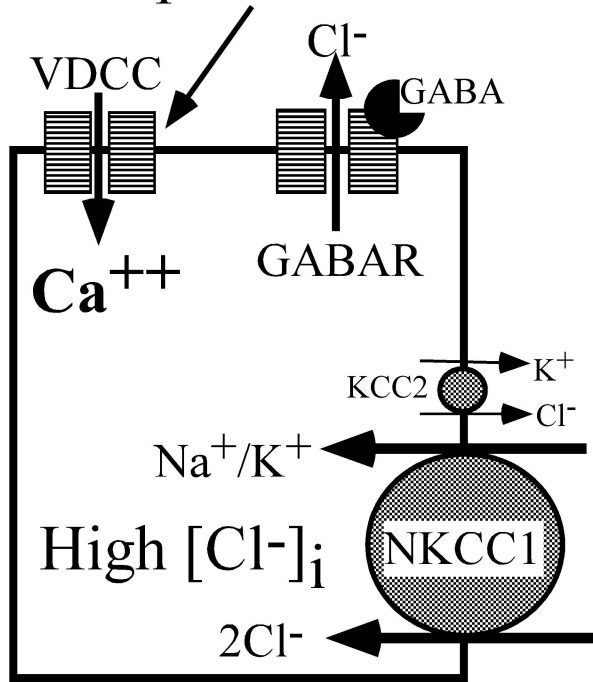

Developing CNS

B Hyperpolarization

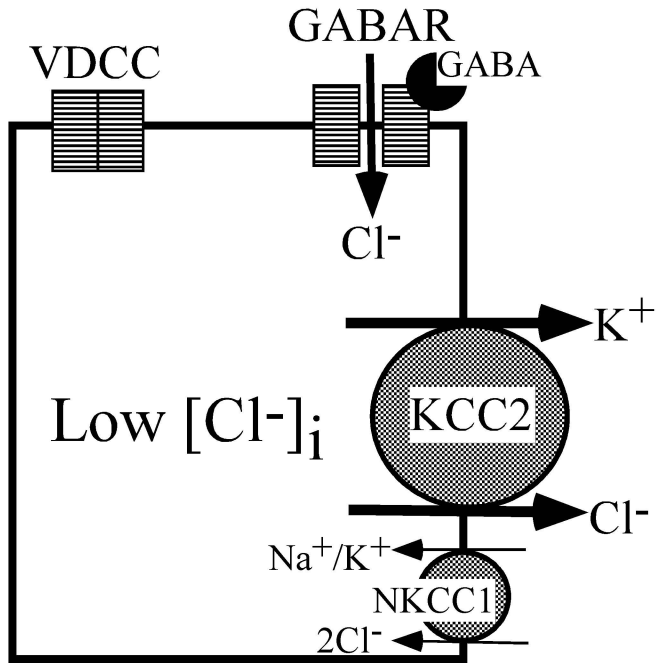

Mature CNS

