



Title	Development of a TOF measurement system of charge carrier dynamics in diamond thin films using a UV pulsed laser
Author(s)	Fujita, F.; Oshiki, Y.; Kaneko, J.H. et al.
Citation	Diamond and Related Materials, 15(11-12), 1921-1925 <a href="https://doi.org/10.1016/j.diamond.2006.09.004">https://doi.org/10.1016/j.diamond.2006.09.004</a>
Issue Date	2006
Doc URL	<a href="https://hdl.handle.net/2115/17257">https://hdl.handle.net/2115/17257</a>
Type	journal article
File Information	D&RM15_11-12.pdf



**Title: Development of a TOF Measurement System of Charge Carrier Dynamics in Diamond Thin Films using a UV Pulsed Laser**

**Authors: F. Fujita, Y. Oshiki, J.H. Kaneko, A. Homma, K. Tsuji, K. Meguro, Y. Yamamoto, T. Imai, H. Watanabe, T. Teraji, S. Kawamura, M. Furusaka**

**Corresponding Author:**

Fumiyuki Fujita

North 13, West 8, Kita Ku

Sapporo 060-8628

Japan

Telephon Number +81 011 706 6679

Fax Number +81 011 706 6678

Email: [ffujita@qe.eng.hokudai.ac.jp](mailto:ffujita@qe.eng.hokudai.ac.jp)

**Prime Novelty Statement:**

A fast TOF measurement system for transport behavior of free-charged carriers in intrinsic diamond films by using a UV pulsed laser was developed. The UV laser light narrowed to less than 80  $\mu\text{m}$  widths could locally create hole-electron pairs in selected locations on a diamond film between two separated electrodes on the surface. This system made it possible to measure true behavior of charge carriers in the diamond films, because charge carriers run in diamond without disturbance caused by laser irradiation. In addition, the local irradiation system succeeded to reduce an influence of photoelectrons created at electrodes by laser irradiation. For one of diamond film used for confirmation of the TOF system, transit time of holes was measured as 4.7 ns with covering a distance of 250  $\mu\text{m}$ .

**Authorship Statement:**

The submission of the manuscript has been approved by all co-authors.

**Keywords:**

CVD diamond films, carrier drift velocity, time-of-flight, UV pulsed laser, local irradiation

**Estimated Word Count:**

5 figures ( $\times$  250) = 1250

2674 word text = 2674

Total = 3924

**Development of a TOF Measurement System of Charge Carrier Dynamics in Diamond Thin  
Films using a UV Pulsed Laser**

F. Fujita<sup>a</sup>, Y. Oshiki<sup>a</sup>, J.H. Kaneko<sup>a</sup>, A. Homma<sup>a</sup>, K. Tsuji<sup>a</sup>, K. Meguro<sup>b</sup>, Y. Yamamoto<sup>b</sup>, T. Imai<sup>b</sup>,  
H. Watanabe<sup>d</sup>, T. Teraji<sup>c</sup>, S. Kawamura<sup>a</sup>, M. Furusaka<sup>a</sup>

<sup>a</sup> *Hokkaido University, North 13, West 8, Kita-ku, Sapporo 060-8628, Japan*

<sup>b</sup> *Sumitomo Electric Industries, Ltd., Japan*

<sup>c</sup> *Osaka University, Japan*

<sup>d</sup> *National Institute Advanced Industrial Science and Technology, Japan*

[Abstract]

A fast TOF measurement system with 150 ps time resolution for transport behavior of free charge carriers in an intrinsic diamond film by using a UV pulsed laser was developed. The 213nm UV laser light narrowed to approximately 80 μm widths could locally create hole-electron pairs in selected locations on a diamond film between two parallel electrodes on the surface. This system measured accurate charge transport characteristics in a diamond film, because created charge carriers moved in a part of the diamond film where did not get any influence from the laser irradiation. Diamond samples used for verification of the TOF system were intrinsic CVD diamond films with thickness between 4 to 10 μm grown on HP/HT diamond

substrates. Transit time of holes for one diamond film was 4.7 ns with a traverse distance of 250  $\mu\text{m}$ . The local irradiation of laser made it possible to measure transport characteristics of electrons and holes separately. In addition, it substantially reduced influence of photoelectron, because laser beam did not irradiate electrodes. Through several examinations, excellent reliability of the TOF system was confirmed.

**Keywords:** CVD diamond films, carrier drift velocity, time-of-flight, UV pulsed laser

## 1. Introduction

Continuing endeavor has been devoted to developing diamond p-i-p high-frequency field effect transistors (FETs) [1,2]. Saturated drift velocities in the i-layer of the diamond FETs determine the upper limits of their performance. Therefore, it is an important subject to measure charge carrier transport characteristics of intrinsic diamond films. The Hall effect is widely exploited to measure carrier density and mobility in semiconductors. However, in the cases of intrinsic wide band gap semiconductors in which few free charge carriers are made thermally, thus it is difficult to assess their charge carrier mobility by the Hall effect. One effective method to measure carrier mobility in intrinsic diamond films is the time-of-flight (TOF) technique.

To create electron-hole pairs to initiate TOF measurements, a pulsed electron beam [3,4], soft x-rays [5], or a UV laser [6,7,8] whose energy were greater than 5.49 eV were used as injection

quanta. For self-standing diamond crystals, a TOF measurement system that was consisted of a 213 nm UV pulsed laser, passive circuits and a digital oscilloscope was previously developed by the authors [9,10]; good linearity of output signals and fast response, i.e. carrier transit time up to 5 ns was achieved.

For diamond thin film, in 1991, Pan et al. developed a TOF measurement system for the same purpose [11]. They used polycrystalline diamond thin films with two parallel electrodes whose gap was 1mm, and laser irradiation was applied uniformly to the region between the electrodes. After this research, endeavor on measuring charge carrier transport characteristics for diamond films has been continued [12-17]. All these system adopted uniform irradiation between electrodes. Thus, photoelectric effect that was caused by irradiation of UV light to electrodes made it impossible to measure carrier transport immediately after that irradiation. Moreover, created charge carriers moved in the irradiated region, there was no confirmation that original transport characteristics of diamond films were observed.

In order to resolve the issues described above, a fast TOF measurement system with local irradiation of UV light was developed. By using homo-epitaxial diamond films with thickness of 4 to 10  $\mu\text{m}$  on HP/HT type IIa and Ib substrates, reliability of the TOF system was examined in this paper.

## **2. Experimental**

### *2.1 TOF measurement system*

Figure 1 (a) shows a schematic diagram of the developed TOF measurement system for intrinsic diamond films. This system adopted an UV pulsed laser, Quanta System SYL A1/NFC, as excitation source. UV light of 213 nm, photo energy of 5.807 eV, was created as fifth higher harmonic of a basic Nd:YAG laser light. Time duration and average power of a UV light pulse were 100 ps and approximately 6 mJ/pulse, respectively. By using quartz prism, only a component of 213 nm was selected. Then the UV light was collimated by a slit and transformed into a state of sheet whose width was less than 100  $\mu\text{m}$ . Therefore, the UV light could locally irradiate on a diamond film. Figure 2 (a) shows a cross section of a diamond sample, and Fig. 2 (b) shows a photograph of a top view of a sample with two parallel electrodes. Using this system, charge carriers could be created locally between the electrodes. Varying of the irradiation location could alter the transit distances of the charge carriers. The two salient parameters could be altered in this system: an electric field and transit distance.

DC bias voltage was applied to one of the two electrodes on a diamond film surface. The other electrode was grounded through a coaxial cable, RG-58A/U, whose impedance was 50  $\Omega$ . Current caused by motion of charge carriers were converted into voltage through this load. The coaxial cable was connected to a digital storage oscilloscope through a SMA connector whose analog bandwidth was 26.5 GHz. For conventional TOF measurement systems, sometimes a time constant and/or bandwidth of a measurement circuit govern time response of a total measurement system. On the other hand, for this TOF measurement system, the time response of circuit was determined solely by the frequency characteristics of the coaxial cable and the

connector; therefore very fast time response was confirmed. Finally, the signals were measured and recorded by a LeCroy Wave Master 8600AS digital storage oscilloscope whose analog bandwidth was 5 GHz and sampling rate was 20GS/s.

If it is possible to ignore a photoelectric effect and a space charge effect, a shape of a signal should be a square wave for an ideal diamond film without any trapping for charge carriers. The signal is formed by induced charge that is caused by motion of charge carriers created by UV laser light irradiation and an electric field between the electrodes. When the last charge carriers arrive at the electrode, induced charge current is stopped. However, for actual diamond, there is trapping on charge carriers. Therefore, for accurate evaluation of charge carriers' transportation characteristics, simulation of output signals that is described elsewhere is very important [18].

## *2.2 Measurement of width of sheet shape UV laser light*

Figure 1 (b) shows figure of components around an diamond sample which should be evaluated. A diamond sample and a readout circuit were set in a chassis case whose size was 50 × 50 × 30 mm. This chassis case was fixed on linear rail with a UV sensor; position resolution of the linear rail was 10 μm. A stainless steel slit with gap of 50 μm was set in front of the UV sensor

Spatial intensity distribution of the UV laser light that was focused by the cylindrical lens was measured by using this peripheral additional system. Figure 3 shows an example of a

laser light intensity distribution at surface of a diamond film. For this case, using Gaussian fitting for obtained data, width of sheet shape UV laser light was measured narrower than 80  $\mu\text{m}$ .

### *2.3 Diamond thin films used for confirmation of the TOF measurement system*

To verify function of the TOF measurement system, two diamond films were prepared. Both diamond films were grown by plasma-assisted CVD method on surfaces of (100) of HP/HT single diamond substrates. Sample #1 was synthesized by Osaka University; diamond film of 10  $\mu\text{m}$  in thickness was grown on a type IIa diamond substrate. Sample #2 was synthesized by National Institute of Advanced Industrial Science and Technology (AIST); diamond film of 4.5  $\mu\text{m}$  in thickness was grown on a type Ib diamond substrate. Two parallel electrodes were fabricated on the surface of the diamond films as shown in Fig. 2 (b) by evaporation. Before the evaporation process, the surfaces of the diamond films were terminated by oxygen. To achieve higher bias voltage, a platinum Schottky contact and a Ti/Au ohmic contact were chosen for these diamond films. A size of the electrode was 0.5mm  $\times$  2.5 mm  $\times$  70 nm. A gap between the two electrodes was 500  $\mu\text{m}$ .

## **3. Results and Discussion**

### *3.1 Preparatory measurements*

At first, absorption coefficient of high-quality diamond was confirmed in order to recognize influence of the UV light of 213 nm to a substrate. Intensity of the UV light was measured at front and backside of a type IIa HP/HT diamond whose thickness was 100  $\mu\text{m}$ . The ratio of intensities was smaller than  $10^{-4}$ , the absorption coefficient:  $9.2 \times 10^4 \text{ m}^{-1}$ . Therefore, the penetration length of 213 nm UV light in the type IIa diamond was shorter than 10  $\mu\text{m}$ . This value was almost consistent with the value reported in Ref. [19]. From this result, it was confirmed that influence of UV light irradiation to substrate should be taken into account.

For a HP/HT type IIa diamond substrate, it was obvious that motion of charge carriers in the substrate made influence on output signals, because a radiation detector made of the type IIa diamond had sensitivity even to an alpha particle. On the other hand, for a HP/HT type Ib diamond substrate, influence of UV light irradiation was unknown. A radiation detectors made of the type Ib diamond sometimes had response to alpha particles; usually signals were very slow in order of ms. For the fast TOF measurement, influence of motion of charge carriers in the type Ib diamond substrate was negligible if excitation was done by alpha particles. However, the high power UV laser was used in this TOF measurement. Thus, two electrodes were evaporated on the surface of the type Ib substrate, and TOF measurement was carried out; there was no signal except noises. From this result, it was concluded that charge transport characteristics of the CVD diamond film, i.e. sample #2, was possible to measure without any influence from the type Ib diamond substrate. In any case, influence from substrates, especially for high quality substrates, should be checked in this measurement.

In addition, leakage current versus bias voltage (I-V) characteristics of the diamond samples were measured by using a Keithley 237 high voltage source measure unit. For these two samples, a strong rectification characteristic was not observed; therefore, it was possible to assume that a constant electric field existed between the electrodes. On the other hand, in the case of a diamond film that has a very slight conductivity, a depletion layer grows from the Schottky contact side with an increase of bias voltage. For this type of sample, capacitance versus bias voltage characteristics should be measured to evaluate a depth of the depletion layer.

### *3.2 Confirmation of the TOF measurement system using the diamond films*

To verify function of the TOF measurement system, TOF measurement was carried out by using the two diamond films.

Figure 4 shows an example of TOF measurement signals, i.e. time variation of current, for the sample #1. Bias voltage of 100 V was applied to the Schottky contact, and UV pulsed laser light whose width was 300  $\mu\text{m}$  irradiated at the center between the electrodes. This measurement was conducted to confirm reliability of the TOF system. A trustworthy readout circuit described in the Ref. [9] was used for this measurement; time resolution was limited up to approximately 1 ns. Moreover, a photoelectric peak in Fig. 4 was well suppressed compared with previously measured TOF signals described in the Ref. [9], because the UV laser light did not irradiate the metal electrodes. As a result, it became possible to observe motion of charge carriers just after laser irradiation by subtraction of a photoelectric peak. In Fig. 4, continuous

signal were observed up to 30 ns; it was probably caused motion of holes in the type IIa diamond substrate.

After checking reliability of the new read out circuit, TOF measurement for the sample #2 was carried out. An example of TOF signals obtained by the sample #2 is shown in Fig. 5. To show transit time obviously, vertical axis of Fig. 5 is drawn in semi-logarithmic scale. As described in section 3.1, this signal was caused only by motion of charge carriers in CVD diamond thin film whose thickness was 4.5  $\mu\text{m}$ . Bias voltage of 60 V was applied to the Schottky contact, and 80  $\mu\text{m}$  thick UV laser light irradiated the center of the gap between the electrodes. Judging from rise time of the photoelectric peak, time resolution of the TOF system was reasonable. Influence of the photoelectric peak was limited into duration shorter than 500 ps; thus, a transit time of 1 ns is possible to measure by using this system. After the photoelectric peak, a part composed by motion of electrons and holes and then a part composed by motion of only holes were observed. There was obviously influence of plasma effect; it was difficult to decide start time for charge carriers. If the time when the laser irradiated the diamond film was assumed as  $t=0$ , holes traversed 250  $\mu\text{m}$  in the diamond film in 4.7 ns.

As described above, the fast TOF measurement system with local irradiation mechanism of 213 nm UV pulsed laser was developed successfully. This system could measure reliable charge carriers' transport characteristics in intrinsic diamond films without any influence of laser irradiation. In addition, the system succeeded to suppress the influence of

photoelectric peak caused by irradiation on electrodes. In conclusion, this TOF measurement system works as standard evaluation system for charge transport characteristics in intrinsic diamond films. Moreover, improvement of measurement accuracy with simulation of output signals is indispensable in future.

### **Acknowledgments**

This work was partially supported by grant-in-Aid's for the advanced diamond Device(ADD) program from the New Energy and Industrial Technology Development Organization (NEDO) of Japan. Also a part was supported by KAKENHI (15360498, 17044001).

### **References**

- [1] K. Miyata, K. Nishimura, and K. Kobayashi: IEEE Trans. Electron Devices, **ED-42** (1995) 2010.
- [2] A. Denisenko, W.R. Fahrner, U. Strähle, H. Henshel and R. Job: IEEE Trans. Nuclear Science, **NS-43** (1996) 3081.
- [3] A.A. Quaranta, C. Canali, and G. Ottvilant: Rev. Sci. Instrum. **41** (1979) 1205.
- [4] C. Canali, E. Gatti, S.F. Kozolov, P.F. Manfredi, F. Nava, A. Quirini: Nucl. Instrum. Meth. **160** (1979) 1205.
- [5] L.S. Pan, S. Han, D.R. Kania, K.K. Gan, S. Zhao, et al: Mater. Res. Soc. Symp. Proce. **302**

- (1993) 73.
- [6] C.E. Nebel, J. Muenz, M. Stutzmann, R. Zachai, H. Guetter: *Phys. Rev.* **B55** (1997) 9786.
- [7] E. Lefeuvre, J. Achard, M.C. Castex, H. Schneider, C. Beille, A. Tardieu: *Diamond Relat. Mater.* **12** (2003) 642.
- [8] J. Isberg, J. Hammersberg, E. Johanson, T. Wikstroem, D.J. Twichen, et al.: *Science* **297** (2002) 1670.
- [9] F. Fujita, A. Homma, Y. Oshiki, J.H. Kaneko, et al.: *Diamond and Related Materials*, **14** (2005) 1992-1994.
- [10] Y. Oshiki, J.H. Kaneko, F. Fujita, K. Hayashi, K. Meguro, et al.: *Diamond and Related Materials*, in Press.
- [11] L.S. Pan, D.R. Kania, P. Pianetta, M. Landstrass, O.L. Landon, L.S. Plano: *Surface and Coating Technology*, **47** (1991) 356.
- [12] K. Hayashi, Y. Yokota, T. Tachibana, K. Kobayashi, et al.: *Diamond and Related Materials*, **10** (2001) 1794.
- [13] L.S. Pan, S. Han, D.R. Kania, M.A. Plano, M.I. Landstrass: *Diamond and Related Materials* **2** (1993)820.
- [14] J. Achard, A. Tardieu, A. Kanaev, A. Gicquel, M.C. Castex, Y. Yokota, K. Hayashi, et al.: *Diamond and Related Materials* **11** (2002) 423.
- [15] T. Teraji, Y. Yoshizaki, S. Mitani, T. Watanabe, T. Ito: *J. Appl. Phys.* **96** (2004) 7300.
- [16] M.A. Plano, S. Zhao, C.F. Gardiner, M.I. Landstrass, D.R. Kania, et al.: *Appl. Phys. Lett.* **64**

(1994) 193.

[17] F. Borchelt, W. Dulinski, K.K. Gan, S. Han, J. Hassard, A. Haward, et al.: Nucl. Instrum.

Methods, **A354** (1995) 318.

[18] Y. Oshiki, J.H. Kaneko, F. Fujita, K. Hayashi, K. Meguro, et al.: Proc. ICNDST-11, 2006,

(North Carolina) P1C.16.

[19] E.D. Palik: *Handbook of Optical Constants of Solids*, Academic Press (1985) pp. 665.

## Figure Captions

- Figure 1 (a) Schematic drawing of a TOF system with local UV pulsed laser light irradiation, (b) Photograph of peripheral systems near a diamond sample.
- Figure 2 (a) Cross section of a diamond film used for confirmation of the TOF measurement system, (b) Top view photograph of an example of diamond film with two parallel electrodes, typical gap between two electrodes were 500  $\mu\text{m}$ .
- Figure 3 An example of UV laser light intensity distribution. In this case, thickness of sheet shape UV laser light was narrower than 80 nm.
- Figure 4 An example of TOF signal obtained by the sample #1, i.e. CVD thin film of 10 mm in thickness grown on a type IIa HP/HT diamond substrate. UV laser light of 300  $\mu\text{m}$  in thickness was irradiated at the center of the gap between two parallel electrodes; bias voltage of + 100V was applied to one of the electrodes. Probably, slow signal was caused by motion of holes in the type IIa HP/HT substrate.
- Figure 5 An example of TOF signal obtained by the sample #2, i.e. CVD thin film of 4.5  $\mu\text{m}$  in thickness grown on a type Ib HP/HT diamond substrate. Vertical axis is drawn in logarithmic scale. Bias voltage of 60V was applied to an electrode, and UV laser light whose width was narrower than 80  $\mu\text{m}$  irradiated at the center of the gap between the two electrodes. Signal was caused only by motion of charge carriers in the CVD thin film.

Fig. 1(a)

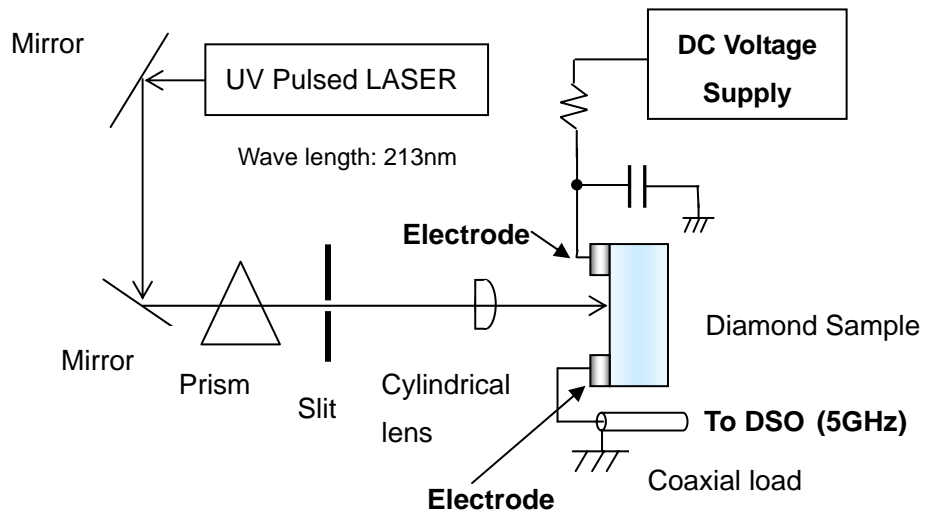

Fig. 1(b)

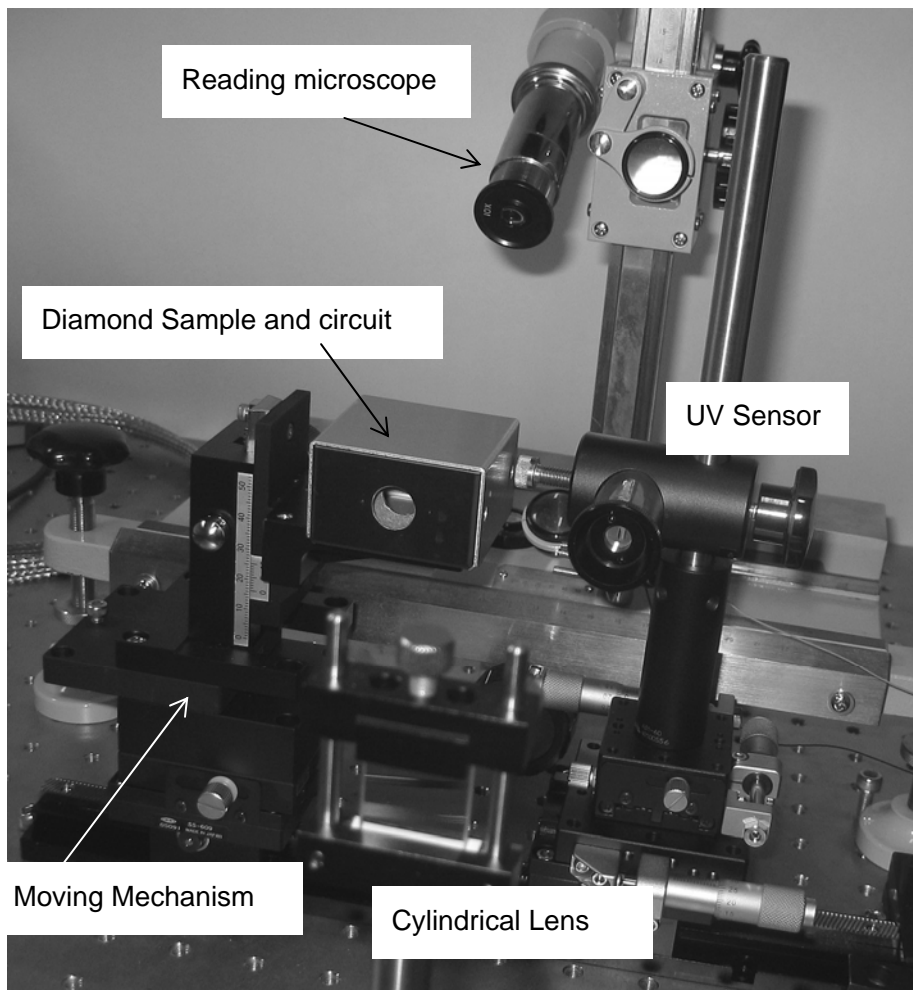

Fig. 2(a)

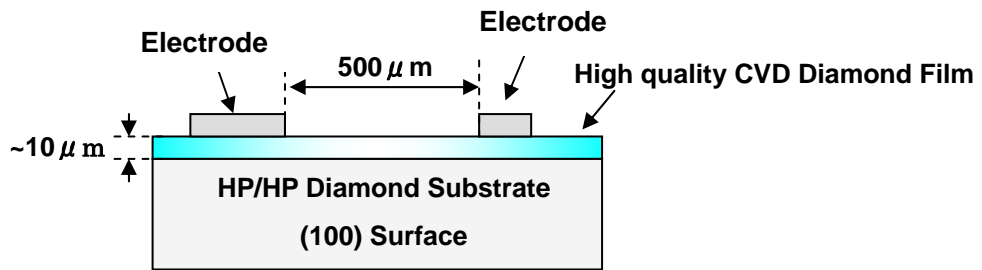

Fig. 2(b)

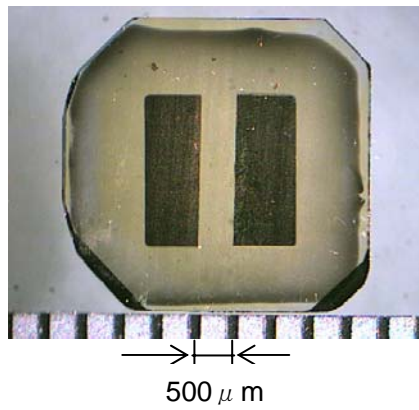

Fig. 3

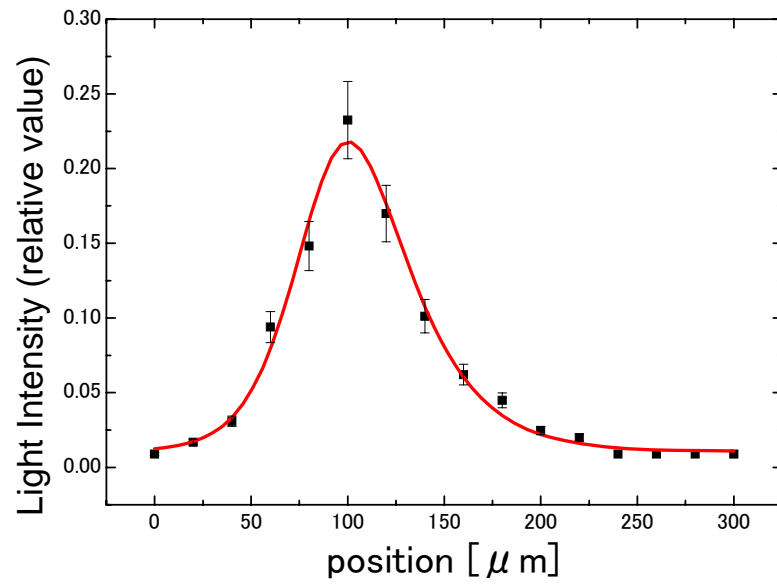

Fig.4

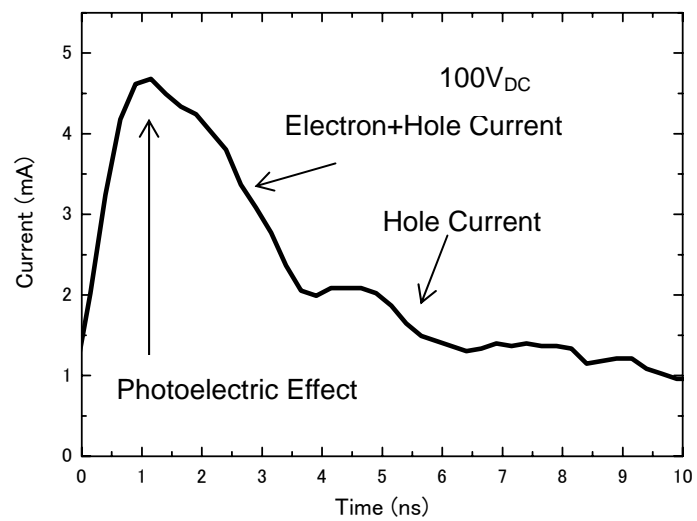

Fig. 5

