



# HOKKAIDO UNIVERSITY

Title	Multiple forms of $\alpha$ -glucosidase in rice seeds ( <i>Oryza sativa</i> L., var Nipponbare)
Author(s)	Nakai, Hiroyuki; Ito, Tatsuya; Hayashi, Masatoshi et al.
Citation	Biochimie, 89(1), 49-62 <a href="https://doi.org/10.1016/j.biochi.2006.09.014">https://doi.org/10.1016/j.biochi.2006.09.014</a>
Issue Date	2007-01
Doc URL	<a href="https://hdl.handle.net/2115/18850">https://hdl.handle.net/2115/18850</a>
Type	journal article
File Information	BI089-1.pdf



## **Title**

Multiple Forms of  $\alpha$ -Glucosidase in Rice Seeds (*Oryza sativa* L., var Nipponbare)

## **Authors**

Hiroyuki Nakai\*, Tatsuya Ito, Masatoshi Hayashi, Koutarou Kamiya, Takeshi Yamamoto, Kazuki Matsubara, Young-Min Kim, Wongchawalit Jintanart, Masayuki Okuyama, Haruhide Mori, Seiya Chiba, Yoshio Sano, Atsuo Kimura\*

## **Affiliation**

Research Faculty of Agriculture, Hokkaido University

## **Full address for correspondence**

Kita-9 Nishi-9 Kita-ku, Sapporo 060-8589, Japan

Telephone and fax number: +81-11-706-2808

E-mail address: nakai@abs.agr.hokudai.ac.jp (for HN), kimura@abs.agr.hokudai.ac.jp (for AK)

## **Abstract**

Two isoforms of  $\alpha$ -glucosidases (ONG2-I and ONG2-II) were purified from dry rice seeds (*Oryza sativa* L., var Nipponbare). Both ONG2-I and ONG2-II were the gene products of ONG2 mRNA expressed in ripening seeds. Each enzyme consisted of two components of 6 kDa-peptide and 88 kDa-peptide encoded by this order in ONG2 cDNA (*ong2*), and generated by post-translational proteolysis. The 88 kDa-peptide of ONG2-I had 10 additional N-terminal amino-acids compared with the 88 kDa-peptide of ONG2-II. The peptides between 6 kDa and 88 kDa components (26 amino-acids for ONG2-I and 16 for ONG2-II) were removed by post-translational proteolysis. Proteolysis induced changes in adsorption and degradation of insoluble starch granules. We also obtained three  $\alpha$ -glucosidase cDNAs (*ong1*, *ong3*, and *ong4*) from ripening seeds. The ONG1, ONG2, and ONG4 genes were situated in distinct locus of rice genome. The transcripts encoding ONG2 and ONG3 were generated by alternative splicing. Members of  $\alpha$ -glucosidase multigene family are differentially expressed during ripening and germinating stages in rice.

## **Key words :**

$\alpha$ -glucosidase isoforms and isozymes; post-translational proteolysis; starch granules degradation;  $\alpha$ -glucosidase multigene family; alternative splicing

## **Abbreviations :**

MalA, *Sulfolobus solfataricus*  $\alpha$ -glucosidase; MALDI TOF-MS, matrix-assisted laser desorption ionization-time of flight mass spectrometry; *ong*, *Oryza sativa* L., var Nipponbare  $\alpha$ -glucosidase cDNA; ONG, *Oryza sativa* L., var Nipponbare  $\alpha$ -glucosidase; ORF, open reading frame; OSG, *Oryza sativa* L., var Shinsetsu  $\alpha$ -glucosidase; PAGE, polyacrylamide gel electrophoresis;

RACE, rapid amplification of cDNA end; SDS, sodium dodecylsulfate; XGOS, xyloglucan oligosaccharide.

## 1. Introduction

$\alpha$ -Glucosidases (EC 3.2.1.20,  $\alpha$ -D-glucoside glucohydrolase) are enzymes that catalyze the liberation of  $\alpha$ -D-glucose from the non-reducing end of oligo- and polysaccharides. These enzymes, which are widespread in mammals, plants, and microorganisms, can be classified into three types based on their substrate specificities [1]. Type I  $\alpha$ -glucosidase hydrolyzes heterogeneous substrates (e.g. synthetic  $\alpha$ -glucosides and sucrose) more rapidly than homogeneous substrates (e.g. maltooligosaccharides), whereas types II and III display higher activity toward homogeneous than toward heterogeneous substrates. Only type III is capable of hydrolyzing polysaccharide substrates (e.g. soluble starch). Plant  $\alpha$ -glucosidases purified from barley [2, 3], buckwheat [4], maize [5, 6], rice [7,8], spinach [9] and sugar beet [10] are type III enzymes.  $\alpha$ -Glucosidases can also be divided into two families based on their primary amino-acid sequences: glycoside hydrolase family (GH) 13 and 31 [11, 12]. GH 13  $\alpha$ -glucosidases have four regions (I-IV) that are conserved in the  $\alpha$ -amylase family [13, 14], whereas GH 31  $\alpha$ -glucosidases have two regions (A and B) containing highly conserved sequences, including the catalytic residues [15]. Plant  $\alpha$ -glucosidase [3, 16-21] is a member of GH 31 enzymes.

Plant  $\alpha$ -glucosidases are hydrolytic enzymes involved in the degradation of storage starch in germinating seeds, and have been generally considered as enzymes converting oligosaccharides produced by  $\alpha$ -amylase,  $\beta$ -amylase and debranching enzyme to glucose [22]. However, plant  $\alpha$ -glucosidases have been reported to hydrolyze soluble starch effectively [23] and to degrade starch granules present as insoluble polysaccharides in plant seed [24-28]. In addition, these enzymes acted synergistically with plant  $\alpha$ -amylases in the degradation of starch granules [24, 25, 29].

Plant  $\alpha$ -glucosidases exist as multiple forms, which differ in molecular size and substrate specificity [9, 24, 30]. Barley genome contains a single  $\alpha$ -glucosidase gene induced by gibberellic acid and two putative genes or pseudogenes [16]. In contrast, spinach contains four multiple

forms of  $\alpha$ -glucosidases, which are thought to be formed by post-translational modification [19]. The existence of multiple forms of plant  $\alpha$ -glucosidases may be due to multiple gene loci and/or post-translational modification. Most plant  $\alpha$ -glucosidases have smaller molecular sizes than those calculated from their deduced amino-acid sequences. For example, the deduced molecular mass of barley  $\alpha$ -glucosidase (low pI-type) was 97 kDa, whereas electrophoretic analysis showed a mass of 81 kDa [31].

Rice  $\alpha$ -glucosidase has been purified from dry seeds (i.e. after harvest) of various species, including *Oryza sativa* L., var Koshihikari [32], var Onnemochi [33], and var Shinsestu [34], from the ripening seeds of var Yashiromochi [35], and from the germinating seeds of Thai rice, *Indica* type [36]. All of these seeds contained multiple forms of  $\alpha$ -glucosidases, which differed in molecular weight, isoelectric point, and kinetic parameters. Although genetic investigation is necessary to elucidate the mechanism behind the production of multiple forms of these enzymes, the primary structures of rice  $\alpha$ -glucosidases have never been determined. In this paper, we have cloned an  $\alpha$ -glucosidase (ONG2) cDNA from ripening rice seeds (*Oryza sativa* L., var Nipponbare), determined its amino acid sequence, purified the two  $\alpha$ -glucosidase isoforms (ONG2-I and ONG2-II) produced by post-translational proteolysis, and isolated three  $\alpha$ -glucosidase cDNAs (*ong1*, *ong3*, and *ong4*). Using a map of the rice (*O. sativa*, Nipponbare) genome sequence (<http://rgp.dna.affrc.jp>) [37], and functional analysis of the Rice Annotation Project Database [38], we localized the  $\alpha$ -glucosidase genes in the rice chromosome. Our findings indicate that multiple forms of rice  $\alpha$ -glucosidases are derived from post-transnational proteolysis and alternative splicing, in addition to gene locus. Proteolytic cleavage affects degrading-activity to starch granules without changing activity to soluble substrates (maltooligosaccharides,  $\alpha$ -glucobiose, and soluble starch).

## 2. Materials and Methods

### 2. 1. *Plant materials*

Dry rice seeds (*O. sativa*, Nipponbare) were kindly supplied by Shiga Prefecture Agricultural Technology Promotion Center (Azuchi-cho, Japan). The seeds were germinated on wet filter paper at 30°C in the dark, and the germinating seeds were collected at 0 (dry seeds), 4, 8, 12, 24, 48, 72, 96, and 148 h after imbibition. Ripening rice seeds were harvested on 4, 5, 8, 12, 16, and 20 days after flowering from plants grown at an experimental field of Hokkaido University in Sapporo, Japan. All ripening and germinating seeds were stored at -80°C until use. To measure enzyme activity, ripening, dry, and germinating rice seeds (100 each) were ground in 40 ml of ice-cold 0.1 M sodium phosphate buffer (pH 6.0) by Polytron PT10-35 (KINEMATICA AG, Lucerne, Switzerland), and centrifuged at 20,000 x g for 12 min at 4°C.

### 2. 2. *Substrates*

Maltose and soluble starch were purchased from Nacalai Tesque Chemical Inc. (Kyoto, Japan); maltotriose from Wako Pure Chemical Ind., Ltd. (Osaka, Japan); isomaltose and phenyl  $\alpha$ -glucoside from Sigma Co. (St. Louis, MO, USA); 4,6-*O*-benzylidene *p*-nitrophenyl  $\alpha$ -D-maltoheptaoside from Megazyme International Ireland Ltd. (Wicklow, Ireland). Malto-tetraose, -pentaose, -hexaose, -heptaose, nigerose and rice starch granules were kindly supplied by Dr. Nakakuki, Nihon Shokuhin Kako Co., Ltd. (Tokyo, Japan). To remove possible impurities, maltose was further purified by repeated crystallizations. Kojibiose were enzymatically synthesized through transglucosylation by buckwheat  $\alpha$ -glucosidase [39, 40]. Xyloglucan oligosaccharides mixture (XGOS) was obtained as described [41].

### **2. 3. Enzyme purification**

#### *Crude extract and ammonium sulfate fractionation*

All purification procedures were performed at 4°C. Dry rice seeds (2.8 kg) milled finely in grinder (30 mesh; Grinder type TFO, Hitachi, Ltd., Tokyo, Japan) were stirred in 7,000 ml of 67 mM sodium phosphate buffer (pH 7.6) for 24 h. The solution was centrifuged at 13,500 x g for 10 min, and the supernatant was filtered through a thick bed of Celite No. 535 (Wako Pure Chemical Ind., Ltd.) to obtain crude extract. Ammonium sulfate was added to the crude extract to 70% saturation, and the suspension was maintained at 4°C for 16 h. The precipitate was collected by centrifugation at 13,500 x g for 20 min, dissolved in 500 ml deionized water, and dialyzed against deionized water. After obtaining the 20%-50% ammonium sulfate fraction, the precipitate was collected by centrifugation at 13,500 x g for 20 min, dissolved in 280 ml of deionized water, and dialyzed against 50 mM sodium acetate buffer (pH 4.7). Insoluble material was removed by centrifugation, and the supernatant was dialyzed against 50 mM sodium acetate buffer (pH 6.2).

#### *Chromatographic separations*

The dialyzed solution was applied to a CM-Sepharose CL-6B column (3.6 x 38 cm) equilibrated with 50 mM sodium acetate buffer (pH 6.2) at a flow rate of 75 ml/h. After the column was thoroughly washed with the same buffer, it was eluted with a linear gradient of 0-1.0 M NaCl in the same buffer at a flow rate of 100 ml/h. Active fractions were concentrated with a Collodion Bag (Sartorius K.K., Tokyo, Japan), dialyzed against 50 mM sodium acetate buffer (pH 4.7) containing 50 mM NaCl, and applied to a Sephadex G-100 column (3.6 x 100 cm) in the same buffer at a flow rate of 16 ml/h (procedure A). Active fractions were concentrated, dialyzed against 25 mM sodium phosphate buffer (pH 8.3) and applied to a second CM-Sepharose CL-6B column (1.8 x 30 cm) at a flow rate of 18 ml/h, followed by a linear gradient of 0-0.8 M NaCl

containing the same buffer at a flow rate of 40 ml/h (procedure B).  $\alpha$ -Glucosidase activity was separated into three fractions (see Fig. 1): ONG1 (Nos. 3-17; non-adsorbed fraction), ONG2-I (Nos. 72-75; adsorbed fraction), and ONG2-II (Nos. 76-81; adsorbed fraction). ONG1 was concentrated to 2 ml with a Collodion Bag and applied to a Sephadex G-100 column (1.8 x 55 cm) using procedure A. ONG2-I and ONG2-II were further purified on a CM-Sepharose CL-6B column (1.4 x 25 cm; using procedure B), followed by a Sephadex G-100 column (1.8 x 50 cm for ONG2-I; 2.2 x 76 cm for ONG2-II; using procedure A). All enzymatically active fractions were stored at 4°C.

#### **2. 4. Assays of enzyme activity, measurement of protein, and carbohydrate content**

Reaction mixture containing of 0.2 ml 0.5% maltose (or 0.5% XGOS), 0.1 ml enzyme solution, and 0.2 ml 0.1 M sodium acetate (pH 4.5) was incubated at 37°C. To measure  $\alpha$ -glucosidase activity, the reactions were stopped by addition of 1 ml 2 M Tris-HCl (pH 7.0) and liberated glucose was assayed by a modification [42] of the glucose oxidase method using the Glucose AR-II Test (Wako Pure Chemical Ind., Ltd.).  $\alpha$ -Xylosidase activity was determined by assaying xylose using the *p*-bromoaniline method [43, 44]. One unit of  $\alpha$ -glucosidase (or  $\alpha$ -xylosidase) activity was defined as the amount of enzyme hydrolyzing 1  $\mu$ mol maltose (or releasing 1  $\mu$ mol xylose from XGOS) per min. Protein concentration of the crude extract was measured by the Bradford method [45] using bovine serum albumin as the standard. Enzyme concentrations were determined spectrophotometrically from the specific absorption coefficient ( $E_{1\text{cm}}$  at 280 nm) of 16.3 for 1% ONG2-I and ONG2-II, obtained from the relationship between dry weight and optical density of the purified preparations. Carbohydrate contents of the purified enzyme preparations were estimated as mannose or glucose by the phenol-sulfuric acid method [46].

#### **2. 5. Enzyme analysis**

### *Electrophoresis*

Native polyacrylamide gel electrophoresis (native-PAGE) under non-denaturation conditions was performed on 7.5% polyacrylamide gel as described [47]. Protein bands were visualized with Rapid CBB KANTO (Kanto Chemical Co., Inc., Tokyo, Japan). Activity staining was performed by incubating the gel at 37°C for 5 min with 2 mM 4-methylumbelliferyl  $\alpha$ -D-glucoside in 0.1 M sodium acetate buffer (pH 4.5), and the released 4-methylumbelliferone was detected by UV transillumination. Sodium dodecylsulfate polyacrylamide gel electrophoresis (SDS-PAGE) under denaturing conditions was performed as described [48], using 15% (w/v) acrylamide for separation gel.

### *Effects of pH and Temperature*

For pH-activity, reaction mixtures consisted of 0.2 ml 0.5% maltose, 0.1 ml enzyme solution (0.718  $\mu$ g for ONG2-I and 0.880  $\mu$ g for ONG2-II), and 0.2 ml 40 mM Britton-Robinson buffer (40 mM acetic acid, 40 mM phosphoric acid and 40 mM glycine, adjusted to pH 2.5-8.0 by NaOH), which were incubated at 37°C for 10 min. For pH-stability, reaction mixtures consisted of 10  $\mu$ l enzyme solution (0.957  $\mu$ g for ONG2-I and 0.733  $\mu$ g for ONG2-II) and 90  $\mu$ l 40 mM Britton-Robinson buffer (pH 2.3-12.5). Following incubation at 4°C for 24 h, 0.2 ml 1 M sodium acetate (pH 4.5) and 0.2 ml 0.5% maltose were added, and enzyme activity was measured by incubation at 37°C for 10 min. For thermal stability, reaction mixtures consisted of 0.1 ml enzyme solution (0.718  $\mu$ g for ONG2-I and 0.880  $\mu$ g for ONG2-II) and 0.2 ml 0.1 M sodium acetate (pH 4.5). The mixtures were incubated at 30°C to 70°C for 10 min and cooled to 0°C. After the addition of 0.2 ml 0.5% maltose, residual activity was measured at 37°C for 10 min.

### *Substrate Specificity*

Soluble starch (0.57-2.9 mM, representing the concentration at the non-reducing terminal [49, 50]), isomaltose (10-40 mM), kojibiose (0.40-1.5 mM), nigerose (1.0-5.0 mM), phenyl  $\alpha$ -glucoside (1.8-12 mM) and a series of maltooligosaccharides including maltose (1.2-10 mM), malto-triose (0.9-6.0 mM), -tetraose (0.9-6.0 mM), -pentaose (0.60-2.5 mM), -hexaose (0.64-2.5 mM), and -heptaose (0.8-3.0 mM) were used as substrate. Initial velocity was measured by glucose liberated from the non-reducing terminal of the substrate. Michaelis constant ( $K_m$ ) and molecular activity ( $k_0$ ) were estimated by Lineweaver-Burk plots ( $1/s-1/v$  plots) with experimental error less than 2%.

#### *Starch granules binding and degrading assays*

Rice starch granules were washed five times with 0.1 M sodium acetate buffer (pH 4.5) to remove remaining soluble sugars. In the binding assay, 500  $\mu$ l reaction mixture, containing 0.35  $\mu$ M enzyme and 5 mg starch granules, was incubated at 4°C in 0.1 M sodium acetate buffer (pH 4.5) containing 0.05% BSA and 5% ammonium sulfate. After 10, 20, 40, and 60 min, the starch granules were removed by centrifugation at 10,000  $\times$  g for 1 min, and  $\alpha$ -glucosidase activity in the supernatant was measured. The enzyme bound to starch granules was evaluated from the activity remaining in the supernatant. Under these conditions, glucose released from starch granules (less than 3.8  $\mu$ g/ml of supernatant) had no effect on  $\alpha$ -glucosidase activity. To measure degrading ability, 500  $\mu$ l reaction mixture as above was incubated at 37°C in 0.1 M sodium acetate buffer (pH 4.5) containing 0.05% BSA for 0.1, 0.3, 1, 2, and 4 h. After centrifugation, glucose concentrations in the supernatant were measured.

#### *In-gel Digestion by Trypsin and MALDI TOF-MS*

The 6 kDa and 88 kDa bands of purified enzyme were removed from SDS-PAGE gels. Each gel piece was washed three times with 100  $\mu$ l 60% 50 mM  $\text{NH}_4\text{HCO}_3$  (pH 7.8)/40% acetonitrile at

37°C for 20 min, and dried by vacuum centrifugation (CENTRIFUGAL VAPORIZER CVE-100, EYELA, Tokyo, Japan) at room temperature for 20 min. Each dried gel piece was soaked in 5 µl trypsin solution [0.1 M Tris-HCl buffer (pH 8.0), 0.01% trypsin, and 10 mM CaCl<sub>2</sub>], followed by the addition of 15 µl 50 mM NH<sub>4</sub>HCO<sub>3</sub> (pH 7.8). After each protein was digested at 37°C for 20 h, the peptides extracted with 100 µl 60% acetonitrile were dried by vacuum centrifugation, dissolved in 5 µl 0.1% trifluoroacetic acid, and desalted using ZipTip (Millipore, Co., Bedford, MA, USA). The peptide mixture was analyzed by MALDI TOF-MS (matrix-assisted laser desorption ionization-time of flight mass spectrometry; Voyager DE-STR, Perceptive Biosystems, Framingham, MA, USA).

#### *Analysis of N-Terminal Amino-acid Sequence*

Following SDS-PAGE of purified enzyme, the gel was equilibrated with blotting buffer (30 mM Tris, 17 mM boric acid, 0.055% SDS, and 20% methanol), and the proteins were transferred to ProBlott™ membranes (Applied Biosystems, Inc., Foster City, CA, USA) by a transblotting system (MARYSOL Co., Tokyo, Japan), and stained with Coomassie Brilliant Blue G-250 (Nacalai Tesque Chemical Inc.). Protein bands were removed from the membrane and applied to a protein sequencer (model 477A, Applied Biosystems, Inc.) with an on-line phenylthiohydantoin analyzer (model 120A, Applied Biosystems Inc.).

#### *Analysis of Inner Amino-acid Sequence*

Purified enzyme (1 nmol) was reduced and *S*-pyridylethylated with 150 mM 2-mercaptoethanol and 140 mM 4-vinylpyridine in 0.01 M Tris-HCl (pH 8.0) containing 8 M urea and 10 mM EDTA. After dialysis against 10 mM sodium acetate buffer (pH 4.5) and water overnight, *S*-pyridylethylated protein was dried by vacuum centrifugation and dissolved in 0.2 ml

0.01 M Tris-HCl (pH 8.0) containing 4 M urea, followed by digestion with 10 pmol Lysyl Endopeptidase (Wako Pure Chemical Ind. Ltd.) at 30°C for 24 h. Peptides were separated by reversed phase-HPLC on a C8P-50 column (Asahikasei Asahipak Column, 4.6 x 150 mm; Osaka, Japan) using a gradient of 0-80% acetonitrile in 0.1% trifluoroacetic acid. The resulting peptides were subjected to sequence analysis.

## **2. 6. Analysis of the Gene**

### *mRNA Preparation*

Total RNA was extracted from ripening, dry, and germinating seeds using the SDS/phenol method [51]. Poly(A)<sup>+</sup> RNA was isolated with Oligo-dT30 Super (TaKaRa Biomedicals, Tokyo, Japan).

### *Construction of cDNA Library and Isolation of ong4*

Total RNA, extracted from ripening seeds harvested on 4 days after flowering, was used to construct a cDNA library. Double-stranded cDNA was synthesized from poly(A)<sup>+</sup> RNA using a Super Script<sup>TM</sup> Lambda System for cDNA Synthesis and  $\lambda$ Cloning (GIBCO BRL, Life Technologies, Inc., Rockville, MD, USA). Phage vector  $\lambda$ gt11 carrying *ong4* at the *EcoRI* site was packaged into bacteriophage particle using Giapack III Gold Packaging Extract (Stratagene Cloning System, La Jolla, CA, USA), and the bacteriophage was used to infect and propagate in *E. coli* C600 hfl. About  $1 \times 10^5$  plaques were transferred to Hybond-N<sup>+</sup> membranes (Amersham, Buckinghamshire, UK), which were incubated overnight at 68°C with the probe labeled by digoxigenin (DIG-High Prime, Boehringer Mannheim Biochemica, Mannheim, Germany) in hybridization buffer (Boehringer Mannheim Biochemica). The probe was generated from genomic DNA by PCR amplification using *Taq* polymerase and primers,

5'-GAIGTIATATGGICAGAIATIGAITAIATG-3' (sense, corresponding to Asp334-Met343 of ONG4; see Fig. 5) and 5'-AAIAAITAIAAIGCICCIAGITGIATCCAICG-3' (antisense, corresponding to Arg619-Phe629 of ONG4, in fact Glu622 and Pro628 being respectively Gln and Phe for synthesis of the primer). Both PCR primers were constructed based on the well-conserved amino-acid sequences of plant  $\alpha$ -glucosidases using deoxyinosine at the degenerate base position, since the DNA sequence of ONG4 was not reported by rice genome sequencing project [37] when this experiment was performed. After hybridization, the membranes were washed at 68°C with 2 x SSC [0.3 M NaCl and 30 mM sodium citrate], 0.1% SDS and 0.1 x SSC, 0.1% SDS and exposed to Kodak Scientific Imaging Film X-OMAT™ AR (Kodak, Rochester, NY, USA). A 3.0 kb *NotI* fragment of  $\lambda$  phage DNA isolated from 7 positive clones was subcloned into pBluescript II (Stratagene), and the insert was sequenced in both directions by the dideoxy chain termination method using a DNA sequencer (Applied Biosystems Model 373 A).

#### *Rapid Amplification of cDNA 5' and 3' Ends (5'-RACE and 3'-RACE) of ong1, ong2, and ong3*

Poly (A)<sup>+</sup> RNA was prepared from ripening seeds harvested on 12 days after flowering, and first strand cDNA, linked to the adaptor sequence at the 3' terminal, was synthesized from poly(A)<sup>+</sup> RNA using a Super Script™ First-Strand Synthesis System for RT-PCR (GIBCO BRL, Life Technologies, Inc.) and 3'-AP (5'-GGCCACGCGTCGACTAGTACT<sub>17</sub>-3') containing the adaptor sequence. The first strand cDNA was used as a template for 3'-RACE with primers, 3'-AUAP (antisense, 5'-GGCCACGCGTCGACTAGTA-3') and 5'-CCIGTIGAIGGIITITGGGTIGAIATGAA-3' (sense, corresponding to Pro436-Asn445 of ONG2 in Fig. 4, synthesized from the amino-acid sequences conserved in plant  $\alpha$ -glucosidases since sequence of ONG2 was not available at that point in time). Two 3'-RACE products of *ong1-3* were sequenced, one from *ong1* and the other from *ong2* and *ong3* (the sequences of the amplified

products from *ong2* and *ong3* were identical). For 5'-RACE, two antisense primers synthesized from the 3'-RACE products were used, 5'-GCGGAGGTCGTCCCACGTCGCGAA-3', corresponding to Phe542-Arg549 of ONG1, and 5'-GTGGAGGTCCTCCCACGTCGCGGC-3', corresponding to Ala542-His549 of ONG2 and ONG3 (see Fig. 5). Poly (A)<sup>+</sup> was connected to the 3' terminal of first strand cDNA with terminal deoxynucleotidyl transferase (Invitrogen, Carlsbad, CA, USA), and used as a template for 5'-RACE with the above two primers and 5'-AP (5'-GACTCGAGTCGACATCGAT<sub>17</sub>-3') and 5'-AUAP (5'-GACTCGAGTCGACATCGA-3'). Three 5'-RACE products of *ong1-3* were sequenced. To amplify each open reading frame (ORF), the 3'-AUAP primer was used with three sense primers, 5'-TCTCCGTCTCCGGTGCGATCGATGG-3' (corresponding to -3 to 21 nt upstream of the ORF of *ong1*), 5'-GCTATAGACTTTTTGTCTCTGACGGCG-3' (corresponding to 1 to 27 nt upstream of the ORF of *ong2*; see Fig. 4), and 5'-TTCAGTAGCTGCCTCTCCCTCCGTCG-3', (corresponding to 12 to 37 nt upstream of the ORF of *ong3*). Each amplified fragment was sequenced in both directions.

#### *Southern and Northern Blot Analysis*

For southern blotting, genomic DNA was isolated from etiolated rice shoots with the CTAB procedure [52]. Genomic DNA (5 µg) was digested with *Pst*I, *Eco*RI, *Eco*RV, *Hind*III, *Cla*I, *Apa*I, *Not*I, or *Sma*I (TaKaRa Biomedicals), electrophoresed in 0.7% agarose gel and blotted onto Hybond-N<sup>+</sup> membrane (Amersham). The blots were hybridized at 60°C for 16 h with alkaline phosphatase-labeled DNA probe (1-257 nt of *ong1*, 1-254 nt of *ong2*, 1-266 nt of *ong3*, 1-263 nt of *ong4*), which were prepared by RT-PCR and labeled with AlkPhos Direct Labelling and Detection System (Amersham). The blots were subsequently exposed to Hyperfilm ECL (Amersham) for 2 h. For northern blot analysis, 30 µg of total RNA extracted from rice seeds by the SDS/phenol

method were separated on 1.2% agarose-formaldehyde gels, and the resulting blots were hybridized as above.

## Results

### *Purification and Enzymic Properties of Rice $\alpha$ -Glucosidases*

#### *Purification and Identification of Rice $\alpha$ -Glucosidases*

As shown in Fig. 1A, the second CM-Sepharose CL-6B column (pH 8.3) separated the rice  $\alpha$ -glucosidases into three components: the non-adsorbent fraction (ONG1), the adsorbed fraction (ONG2-I) of the minor peak, and the adsorbed fraction (ONG2-II) of the major peak. Although the non-adsorbed component was applied to a Sephadex G-100 column, ONG1 did not give a homogeneous protein band in native-PAGE (Fig. 1B). ONG2-I (3.4 mg) and ONG2-II (21 mg) were purified by CM-Sepharose CL-6B (pH 8.3) and Sephadex G-100 column chromatography (Table 1). Each of the purified enzymes showed a single band with different mobility in native-PAGE, where each protein band coincided  $\alpha$ -glucosidase activity (Fig. 1B and 1C).

The effects of pH and temperature on activity were examined. Both ONG2-I and ONG2-II had optimum activity at pH 4.5, and were stable in the pH range of 2.5 to 10.5. They were stable up to 40°C, and lost activity completely after incubation for 10 min at 60°C. The carbohydrate contents of ONG2-I and ONG2-II were estimated to be 4.8% and 4.7% as mannose, respectively, and 6.8% and 6.7% as glucose, respectively.

The kinetic parameters of ONG2-I and ONG2-II, as determined by their hydrolytic velocities on various concentrations of substrates, were quite similar (Table 2). Both enzymes hydrolyzed not only  $\alpha$ -1,4-glucosidic linkage but also  $\alpha$ -1,2-,  $\alpha$ -1,3-,  $\alpha$ -1,6-glucosidic linkages and synthetic  $\alpha$ -glucoside. While  $K_m$  values for nigerose ( $\alpha$ -1,3) were higher than those for maltose ( $\alpha$ -1,4), the  $k_0$  values for nigerose were higher than those for maltose. The  $K_m$  values for kojibiose ( $\alpha$ -1,2) were lower than those for maltose. The  $k_0$  and  $k_0/K_m$  values for isomaltose and phenyl  $\alpha$ -glucoside were about 10% and 1-4% of those for maltose, respectively, meaning less favorite substrates. The two enzymes could hydrolyze soluble starch at rates comparable to their hydrolysis of

maltooligosacchrides.

It was found that ONG2-I and ONG2-II bound to rice starch granules (Fig. 2A), with the adsorbing ability of ONG2-II being twice that of ONG2-I. In addition, both enzymes liberated glucose from starch granules (Fig. 2B), with ONG2-II being 1.4-fold more rapid than ONG2-I. The direct degradation of starch granules by ONG2-I and ONG2-II was supported by our finding that, in the absence of enzyme, no soluble sugar was liberated from starch granules during incubation at 37°C for 4 h. In addition, the purified enzymes did not hydrolyze the  $\alpha$ -amylase specific substrate, 4,6-*O*-benzylidene *p*-nitrophenyl  $\alpha$ -D-maltoheptaoside, in which the reducing- and non-reducing-terminal glucose residues of maltoheptaose were linked to *p*-nitrophenyl and 4,6-*O*-benzylidene groups, respectively, indicating that there was no contamination of  $\alpha$ -amylase in the ONG2-I and ONG2-II preparations.

### ***Isolation of cDNAs for Rice $\alpha$ -Glucosidases***

#### *Time-course of $\alpha$ -Glucosidase and $\alpha$ -Xylosidase Activities in Rice Seeds*

We found that  $\alpha$ -glucosidase activity increased dramatically in ripening seeds on 12 days after flowering, and remained constant in dry seeds and in germinating seeds after imbibition (Fig. 3). Xyloglucan oligosaccharide-hydrolyzing activity ( $\alpha$ -xylosidase activity) was detected in ripening seeds on 4 days after flowering and in germinating seeds.

#### *Cloning of cDNAs Encoding Rice $\alpha$ -Glucosidases*

Pollination initiates the seed ripening process, at the end of which seeds become dry. Since the  $\alpha$ -glucosidases of dry seeds were thought to be produced during ripening stage, we utilized ripening seeds to clone cDNAs encoding  $\alpha$ -glucosidases. A cDNA library constructed from seeds on 4 days after flowering was screened twice by plaque hybridization using a specific

digoxigenin-labeled probe generated by PCR amplification from genomic DNA. From  $1 \times 10^5$  plaques, we obtained seven positive clones, all of which were confirmed to carry *ong4* by restriction digestion, generating an identical 3 kbp *NotI* fragment. Furthermore, we utilized first strand cDNA from mRNA isolated from ripening seeds on 12 days after flowering as a template for PCR amplification, resulting in the cloning of three more  $\alpha$ -glucosidase cDNAs (*ong1*, *ong2*, *ong3*). The nucleotide and deduced amino-acid sequences of *ong2* are shown in Fig. 4, and the amino-acid sequences of *ong1-4* are compared in Fig. 5.

### ***Characterization of cDNA Encoding Rice $\alpha$ -Glucosidases***

SDS-PAGE analysis showed that ONG2-I and ONG2-II were each composed of two bands, 6 kDa and 88 kDa (Fig. 1D). The N-terminal sequences of the 6 kDa-peptides were identical in both, whereas the N-terminal sequences of the 88 kDa-peptides differed (Table 3). The N-terminal sequences of 6 kDa- and 88 kDa-peptides of both enzymes corresponded to the amino-acid sequences deduced from *ong2* (Fig. 4). Protein bands of ONG2-I and ONG2-II separated by SDS-PAGE were subjected to in-gel trypsin digestion, followed by MALDI-TOF analysis. Masses obtained from 6 kDa- and 88 kDa-peptides were assigned to those calculated from the deduced peptide sequence of *ong2* (Table 4 and Fig. 4). Edman degradation revealed 12 internal peptide sequences (Fig. 5), one of which contained the C-terminal region (Val880-Tyr884). Both sequence analyses (Edman degradation and MALDI-TOF) showed that the 6 kDa-peptides from ONG2-I and ONG2-II possessed amino acid residues Gly33-Glu95 arising from *ong2*, whereas the 88 kDa-peptides possessed amino acid residues Ser123-Tyr885 (ONG2-I) and Ala113-Tyr885 (ONG2-II).

We found that the ORF of *ong2* from the start codon (ATG) at position 28 to a stop codon (TAA) at position 2685 encodes a polypeptide of 885 amino acid residues (Fig. 4) with a calculated

molecular mass of 92,943 Da and a theoretical pI of 8.62. A polyadenylation signal at position 2725 to 2730 was identified 26 bp upstream from the 3'-end of *ong2*. Six N-glycosylation sites, consisting of Asn-X-Ser/Thr, in which X is an amino acid other than Pro or Asp, were identified in the deduced amino-acid sequence of *ong2*. The primary structure showed identities to plant, mammalian and microbial  $\alpha$ -glucosidases: 74% to barley high-pI [3], 57% to spinach [19], 54% to *Arabidopsis* [18], 53% to sugar beet [17], 39% to human lysosomal [53], 38% to rabbit intestinal sucrase [54], 35% to rabbit intestinal isomaltase [54], 54.3% to *Aspergillus niger* [55, 56], 31.5% to *Schizosaccharomyces pombe* [15], and 34% to *Bacillus thermoamyloliquefaciens* [57]. The deduced amino-acid sequence of *ong2* was 92%, 94%, and 61% identical to the deduced amino acid sequences of *ong1*, *ong3*, and *ong4*, respectively (Fig. 5).

Native PAGE of the ONG1 preparation resulted in several bands (Fig. 1B). The N-terminal amino-acid sequence of the main band was AFLVDEEGR (Table 3), which was identical to the amino-acid sequence deduced from *ong1* (Ala39-Arg47, Fig. 5). The primary component of this preparation contained the product of the ONG1 gene.

### ***$\alpha$ -Glucosidase Genes Organization***

The organization of the rice  $\alpha$ -glucosidase genes was investigated by southern blot analysis (Fig. 6). Digests of genomic DNA with *ApaI*, *NotI*, *PstI*, *HindIII*, *EcoRI*, *EcoRV*, *SmaI*, or *ClaI* each resulted in a single prominent band, indicating the high specificity of the probes used. Each of the four  $\alpha$ -glucosidase genes seemed to be monomorphic. The database (<http://rgp.dna.affrc.jp>) of rice genome sequences [37] shows that ONG1, ONG2 and ONG4 genes are located at different genetic loci: AP004989 and AP003728 (AP number used in NCBI Genbank) for ONG1 gene (both have partially overlapped sequence, where ONG1 gene is presented); AP003728 for ONG2 gene; AP002526 for ONG4 gene. The gene encoding ONG4 is located on chromosome 1, and the genes

encoding of ONG1 and ONG2 are situated at distinct loci by this order on chromosome 6. Both gene sequences of ONG2 and ONG3 were identical except for the first-exon (Fig 7). This finding indicates that mRNAs of ONG2 and ONG3 are formed by alternative splicing.

### ***Expression of the $\alpha$ -Glucosidase Genes***

Northern blots showed that, in ripening seeds, ONG4 mRNA was detected as early as 4 days after flowering, reaching a maximum on 8 days after flowering, and declining gradually during further seed maturation (Fig. 8). Transcription of ONG2 mRNA was detected on 12 days after flowering, increasing as maturation progresses. ONG1 and ONG3 mRNAs were also detected on 12 days after flowering, reaching a maximum on 16 days. ONG2 and ONG3 mRNAs were not detected in germinating seeds, but ONG1 and ONG4 mRNAs were observed at 48 h and 3 h after imbibition, respectively.

## Discussion

Rice species have been found to have multiple forms of  $\alpha$ -glucosidases [32-36]. For example,  $\alpha$ -glucosidases in dry seeds of Shinsetsu could be separated into two components by CM-Sepharose CL-6B chromatography at pH 8.3, a non-adsorbed component (Shinsetsu  $\alpha$ -glucosidase I; OSG1) and an adsorbed component (Shinsetsu  $\alpha$ -glucosidase II; OSG2) [34]. In contrast, we found that CM-Sepharose CL-6B chromatography at pH 8.3 could separate Nipponbare  $\alpha$ -glucosidases into three components, a non-adsorbed (ONG1) and two adsorbed (ONG2-I and ONG2-II) components (Fig. 1A). Generally, dry rice seeds contain two types of  $\alpha$ -glucosidases, a low pI enzyme (ONG1 and OSG1) and a high pI enzyme (ONG2-I, ONG2-II and OSG2). Our findings indicate that ONG1 and ONG2 are different gene products (i.e. isozymes). The properties and substrate specificities of ONG2-I and ONG2-II were very similar to those of OSG2 [58]. Although ONG1 was not purified, its properties were also similar to those of OSG1, including its low activity in dry seeds and its low specific activity.  $\alpha$ -Glucosidases in dry seeds were produced during ripening stage (Fig. 3 and Fig. 8), remaining until the end of ripening stage, at which time drying occurred.

ONG2-I and ONG2-II (Table 2), as well as OSG1 and OSG2 [58], have broad substrate specificities, and ONG2-I, ONG2-II and OSG2 have very similar kinetic parameters ( $K_m$  and  $k_0$ ). OSG1, while having the same  $K_m$  values toward substrates as the other three enzymes, had  $k_0$  values 100 to 200-fold less than those of ONG2-I, ONG2-II and OSG2. ONG2-I and ONG2-II hydrolyzed  $\alpha$ -1,4-,  $\alpha$ -1,3-,  $\alpha$ -1,2-, and  $\alpha$ -1,6-glucosidic linkages of  $\alpha$ -glucobioses (in this order), and displayed high activity toward large substrates, including soluble starch and long chain maltooligosaccharides, rather than toward smaller substrate, including  $\alpha$ -glucobioses and short chain maltooligosaccharides. These substrate specificities indicate that these enzymes are type III  $\alpha$ -glucosidases [1]. In addition, their amino-acid sequence similarity classifies ONG2-I and

ONG2-II as GH 31 enzymes, with two conserved regions, Asp438-Phe450 (region A) and Thr534-Trp545 (region B), both of which include the catalytic residues (Asp443 and Asp540) essential for the enzyme reaction [15].

In determining the primary structures of the rice  $\alpha$ -glucosidases, we were interested in determining whether these multiple forms originated from the same or different gene locus and/or whether they underwent post-translational modification. After cloning *ong2* from mRNA of ripening seeds on 12 days after flowering, our sequence analysis of ONG2-I and ONG2-II showed that both enzymes were products of a single gene (Fig. 4). ONG2-I and ONG2-II were each composed of two polypeptides, 6 kDa- and 88 kDa-peptides, which could only be separated under denaturing conditions (Fig. 1D), indicating that they were tightly bound in the native protein (Fig. 1B and 1C). The N-terminal sequence of the ONG2-I 88 kDa-peptide was 10 amino acids longer than that of the ONG2-II 88 kDa peptide, indicative of post-translational proteolysis at distinct cleavage sites, Leu122-Ser123 for ONG2-I and Ala112-Ala113 for ONG2-II. Interestingly, we detected an atypical tryptic peptide (87-ITDADHPRWE-96) after in-gel digestion of both 6 kDa-peptides. Trypsin does not ordinarily cleave between Glu96 and Val97, suggesting that Glu96 is the C-terminal residue of the 6 kDa-peptides of ONG2-I and ONG2-II and indicating that the regions Val97-Leu122 of ONG2-I and Val97-Ala112 of ONG2-II were removed by post-translational proteolysis to generate the two isoforms.

Multiple forms of plant  $\alpha$ -glucosidases have also been observed in barley [24], spinach [9], and sugar beet [30]. The molecular masses of these purified enzymes were smaller than those of the amino-acid sequences deduced from their cDNAs. Barley, spinach, and sugar beet  $\alpha$ -glucosidases have homologous sequences containing the cleavage site of rice  $\alpha$ -glucosidases (Fig. 9B). Similar post-translational proteolysis in the N-terminal regions may produce multiple forms of these plant  $\alpha$ -glucosidases. Furthermore, N-terminal sequences of broccoli  $\alpha$ -glucosidase and

*Arabidopsis*  $\alpha$ -glucosidase I [59] display the high similarity to that of the cleavage site (Fig. 9B). Both  $\alpha$ -glucosidases are thought to be truncated enzymes that lack the N-terminal 130 amino acids. Small polypeptides were not detected in any of the five above-mentioned plant  $\alpha$ -glucosidases, although SDS-PAGE on 15% polyacrylamide gels may detect small polypeptides in these enzymes. Similar to our findings here, we recently detected small and large polypeptides in sugar beet, maize, and buckwheat  $\alpha$ -glucosidases (unpublished results), indicating that proteolysis in the N-terminal region is a general phenomenon in plant  $\alpha$ -glucosidases.

The three-dimensional structure of *Sulfolobus solfataricus*  $\alpha$ -glucosidase (MalA) [60] indicates that GH 31  $\alpha$ -glucosidases are composed of four major domains (N, A, C, and D) and two additional structural elements (subdomains B and B', both in domain A). Structure-based comparisons indicate that cleavage sites (Leu122-Ser123 for ONG2-I, Ala112-Ala113 for ONG2-II, and possibly Glu96-Val97 for ONG2-I and ONG2-II) are located in a loop corresponding to the loop between  $\beta$ 2 and  $\beta$ 3 of domain N (residues 1-153 in MalA). This extremely long loop (residues 17-42 in MalA) is exposed to solvent, allowing proteases to attack the cleavage sites in the equivalent loop of rice  $\alpha$ -glucosidase (Asp89-Leu122 in Fig. 4).

Of especial interest are the possible physiological roles of multiple forms of  $\alpha$ -glucosidase in dry rice seeds and proteolysis of plant  $\alpha$ -glucosidases. During germination of plant seeds, starch granules are degraded by the combination of  $\alpha$ -amylase,  $\beta$ -amylase, debranching enzyme, and  $\alpha$ -glucosidase [22]. Since starch granules are insoluble,  $\alpha$ -amylase is a key enzyme in the initial attack, due to its ability to adsorb to and degrade starch granules. In contrast, the other three enzymes were thought to be devoid of adsorbing or degrading ability. However, barley [24, 25], millet [26, 28], and rice [27]  $\alpha$ -glucosidases were found to be capable of degrading starch granules. Plant  $\alpha$ -glucosidase-catalyzed degradation of starch granules was enhanced synergistically by  $\alpha$ -amylase [24, 25, 29], indicating that no contamination of  $\alpha$ -amylase is required to hydrolyze

starch granules. We showed here that ONG2-I and ONG2-II degraded starch granules directly by our finding that no soluble sugar was liberated from starch granules and that purified rice  $\alpha$ -glucosidases could not hydrolyze the  $\alpha$ -amylase substrate, 4,6-*O*-benzylidene *p*-nitrophenyl  $\alpha$ -D-maltoheptaoside. Thus, under  $\alpha$ -amylase-free conditions, both ONG2-I and ONG2-II could adsorb to and degrade starch granules (Fig. 2). Both enzymes are synthesized during the ripening stage and are present in dry seeds with high activity (0.15 U per seed, see Fig. 3B). Since rice  $\alpha$ -amylase in germinating seeds is expressed after imbibition by *de novo* synthesis [61], these findings suggest the existence of a possible pathway in the germination stage, involving the direct liberation of glucose from starch granules by  $\alpha$ -glucosidase before hydrolysis by  $\alpha$ -amylase.

Although ONG2-I and ONG2-II had almost identical substrate specificities (Table 2), their activities differed in starch granules (Fig. 2), suggesting that proteolytic cleavage controls the degradation of starch granules in rice seeds. Possible precursor protein (“not-digested”  $\alpha$ -glucosidase) of ONG2-I and ONG2-II may exist in dry and/or ripening seeds. However, we were unable to detect a precursor protein in dry seeds. We recently purified two  $\alpha$ -glucosidases from dry seeds of red rice (*Oryza sativa* L., var Akamai): one is a digested enzyme split at the same position as in ONG2-II, whereas the other is undigested (unpublished results). The latter enzyme exhibited significantly higher activity against starch granules than did the former, suggesting that limiting proteolysis in the N-terminal region contributes to the degradation of insoluble polysaccharide. Plant  $\alpha$ -glucosidase may change its activity to the starch degradation by post-translational proteolysis.

This study isolated three putative  $\alpha$ -glucosidase cDNAs (*ong1*, *ong3*, and *ong4*). Nucleotide sequence of *ong1* and *ong4* as well as *ong2* have been already reported by International Rice Genome Sequencing Project [37]. We show in this study that these genes are actually transcribed in rice seeds at different stages of development. Moreover, both ONG2 and ONG3 mRNAs are

found to be formed as alternatively spliced products from a single gene (Fig. 7), whereas each of ONG1, ONG2, and ONG4 genes is located in distinct locus. The ORF of *ong3* is not recorded in the database.

According to the database of rice genome sequence, ONG4 predicted as  $\alpha$ -glucosidase as well as ONG1 and ONG2. The deduced amino-acid sequence of *ong4* was 66% identical to that of *Arabidopsis*  $\alpha$ -xylosidase [62] and nasturtium  $\alpha$ -xylosidase [63], 65% identical to that of potato  $\alpha$ -glucosidase [20, 21], 51% identical to that of *Arabidopsis*  $\alpha$ -glucosidase [18], and 45% identical to that of barley high-pI  $\alpha$ -glucosidase [3]. Plant  $\alpha$ -glucosidase and  $\alpha$ -xylosidase are members of the GH 31 family with highly similar amino-acid sequences [62]. The critical difference in primary structure between the two enzymes is not clear. The pattern of  $\alpha$ -xylosidase activity in ripening and germinating seeds is synchronized with that of ONG4 mRNA (Fig. 3 and Fig. 8). In particular, there was a strong transcriptional signal in ripening seeds on 8 days after flowering, but no obvious  $\alpha$ -glucosidase activity was detected, suggesting the possibility that ONG4 is an  $\alpha$ -xylosidase. A heterologous gene expression study is currently in progress to determine whether *ong4* encodes an  $\alpha$ -glucosidase or an  $\alpha$ -xylosidase.

We found that  $\alpha$ -glucosidase activity dramatically increased after 12 days in the ripening seeds (Fig. 3). This activity was present in dry seeds, and was maintained at an approximately constant level in germinating seeds after imbibition. Northern blot analysis showed that ONG2 mRNA was detected in ripening seeds, but not in dry or germinating seeds (Fig. 8). Moreover, the appearance of enzyme activity was synchronized with that of ONG2 mRNA. Interestingly, mRNAs of ONG1 and ONG3 were increased temporarily during ripening, but then decreased during further maturation (Fig. 8A). These mRNA and enzyme activity patterns can be summarized as: i) the main  $\alpha$ -glucosidases in dry seeds (ONG2-I and ONG2-II) are synthesized only during ripening stage; and ii) alternative splicing, which produces ONG2 and ONG3 mRNAs, is regulated

differently during the last stage of the ripening process. Members of the  $\alpha$ -glucosidase multigene family were differently expressed, forming the various isozymes in rice seeds. It would be of interest to determine the function of the multiple forms of rice  $\alpha$ -glucosidase and the mechanism by which their expression is regulated. We are currently analyzing the physiological roles of these  $\alpha$ -glucosidase isozymes.

## References

- [1] Chiba S., The Handbook of Amylases and Related Enzymes. The Amylase Research Society of Japan, Ed., Pergamon Press, Oxford, 1988, pp. 104-116.
- [2] Im M., Henson C.A., Characterization of high pI  $\alpha$ -glucosidase from germinated barley seeds : substrate specificity, subsite affinities and active-site residues. *Carbohydr. Res.* 277 (1995) 145-159.
- [3] Frandsen T.P., Lok F., Mirgorodskaya E., Roepstorff P., Svensson B., Purification, enzymatic characterization, and nucleotide sequence of high-isoelectric-point  $\alpha$ -glucosidase from barley malt. *Plant Physiol.* 123 (2000) 275-286.
- [4] Kanaya K., Chiba S., Shimomura T., Nishi K., Improved method for purification of buckwheat  $\alpha$ -glucosidase and some kinetic properties. *Agric. Biol. Chem.* 40 (1976) 1929-1936.
- [5] Chiba S., Shimomura T., Purification and some properties of flint corn  $\alpha$ -glucosidase. *Agric. Biol. Chem.* 39 (1975) 1033-1040.
- [6] Matsui H., Yazawa I., Chiba S., Purification and substrate specificity of sweet corn  $\alpha$ -glucosidase. *Agric. Biol. Chem.* 45 (1981) 887-894.
- [7] Murata S., Matsui H., Chiba S., Substrate specificity  $\alpha$ -glucosidase II in rice seed. *Agric. Biol. Chem.* 43 (1979) 2131-2135.
- [8] Ito H., Matsui H., Chiba S., Substrate specificities of glutinous rice  $\alpha$ -glucosidase I and  $\alpha$ -glucosidase II. *Denpun Kagaku* 36 (1989) 189-195.
- [9] Sugimoto M., Furui S., Suzuki Y., Multiple molecular forms of  $\alpha$ -glucosidase from spinach seeds, *Spinacia oleracea* L. *Biosci. Biotechnol. Biochem.* 59 (1995) 673-677.
- [10] Matsui H., Chiba S., Shimomura, T., Purification and properties of an  $\alpha$ -glucosidase in sugar beet seed. *Agric. Biol. Chem.* 42 (1978) 1855-1860.
- [11] Henrissat B., A classification of glycosyl hydrolases based on amino acid sequence similarities. *Biochem. J.* 280 (1991) 309-316.

- [12] Henrissat B., Bairoch A., New families in the classification of glycosyl hydrolases based on amino acid sequence similarities. *Biochem. J.* 293 (1993) 781-788.
- [13] Takata H., Kuriki T., Okada S., Takesada Y., Iizaka M., Minamiura N., Imanaka T., Action of neopullulanase: Neopullulanase catalyzes both hydrolysis and transglycosylation at  $\alpha$ -(1-4)- and  $\alpha$ -(1-6)-glucosidic linkages. *J. Biol. Chem.* 267 (1992) 18447-18452.
- [14] Svensson B., Protein engineering in the  $\alpha$ -amylase family: catalytic mechanism, substrate specificity, and stability. *Plant Mol. Biol.* 25 (1994) 141-157.
- [15] Okuyama M., Okuno A., Shimizu N., Mori H., Kimura A., Chiba S., Carboxyl group of residue Asp647 as possible proton donor in catalytic reaction of  $\alpha$ -glucosidase from *Schizosaccharomyces pombe*. *Eur. J. Biochem.* 268 (2001) 2270-2280.
- [16] Tibbot B.K., Skadsen R.W., Molecular cloning and characterization of a gibberellin-inducible, putative  $\alpha$ -glucosidase gene from barley. *Plant Mol. Biol.* 30 (1996) 229-241.
- [17] Matsui H., Iwanami S., Ito H., Mori H., Honma M., Chiba S., Cloning and sequencing of a cDNA encoding  $\alpha$ -glucosidase from sugar beet. *Biosci. Biotechnol. Biochem.* 61 (1997) 875-880.
- [18] Monroe J.D., Hall B.D., Gough C.M., Stephen A.L., Nucleotide sequence of an  $\alpha$ -glucosidase gene (Accession No. AF014806) from *Arabidopsis thaliana*. *Plant Physiol.* 115 (1997) 863.
- [19] Sugimoto M., Furui S., Suzuki Y., Molecular cloning and characterization of a cDNA encoding  $\alpha$ -glucosidase from spinach. *Plant Mol. Biol.* 33 (1997) 765-768.
- [20] Taylor M.A., George L.A., Ross H.A., Davies H.V., cDNA cloning and characterisation of an  $\alpha$ -glucosidase gene from potato (*Solanum tuberosum* L.). *Plant J.* 13 (1998) 419-425.
- [21] Taylor M.A., Ross H.A., McRae D., Wright F., Viola R., Davies H.V., Copy-DNA cloning and characterization of a potato  $\alpha$ -glucosidase: expression in *Escherichia coli* and effects of down-regulation in transgenic potato. *Planta* 213 (2001) 258-264.
- [22] Dunn, G., A model for starch breakdown in higher plants. *Phytochemistry* 13 (1974)

1341-1346.

- [23] Frandsen T.P., Svensson B., Plant  $\alpha$ -glucosidases of the glycoside hydrolase family 31. Molecular properties, substrate specificity, reaction mechanism, and comparison with family members of different origin. *Plant Mol. Biol.* 37 (1998) 1-13.
- [24] Sun Z., Henson C.A., Degradation of native starch granules by barley  $\alpha$ -glucosidases. *Plant Physiol.* 94 (1990) 320-327.
- [25] Sissons M.J., Macgregor A.W., Hydrolysis of barley starch granules by  $\alpha$ -glucosidases from malts. *J. Cereal Sci.* 19 (1994) 161-169.
- [26] Yamasaki Y., Konno H., Masima H., Purification and properties of  $\alpha$ -glucosidase from millet seeds. *Phytochemistry* 41 (1996) 703-705.
- [27] Iwata H., Isogai A., Utsunomiya H., Itani T., Nishio N., Relationship between the accumulation of starch and  $\alpha$ -glucosidase in rice endosperm. *Nippon Nougai Kagaku Kaishi* 77 (2003) 1130-1136.
- [28] Yamasaki Y., Fujimoto M., Kariya J., Konno H., Purification and characterization of an  $\alpha$ -glucosidase from germinating millet seeds. *Phytochemistry* 66 (2005) 851-857.
- [29] Sun Z.T., Henson C.A., A quantitative assessment of the importance of barley seed  $\alpha$ -amylase,  $\beta$ -amylase, debranching enzyme, and  $\alpha$ -glucosidase in starch degradation. *Arch. Biochem. Biophys.* 284 (1991) 298-305.
- [30] Yoshiki Y., Suzuki Y., Two forms of  $\alpha$ -glucosidase from sugar-beet seeds. *Planta* 148 (1980) 354-361.
- [31] Tibbot B.K., Henson C.A., Skadsen R.W., Expression of enzymatically active, recombinant barley  $\alpha$ -glucosidase in yeast and immunological detection of  $\alpha$ -glucosidase from seed tissue. *Plant Mol. Biol.* 38 (1998) 379-391.
- [32] Awazuhara M., Nakagawa A., Yamaguchi J., Fujiwara T., Hayashi H., Hatae K., Chino M., Shimada A., Distribution and characterization of enzymes causing starch degradation in rice

(*Oryza sativa* cv. koshihikari). J. Agric. Food Chem. 48 (2000) 245-252.

- [33] Ito H., Nakatsu S., Matsui H., Chiba S., Purification and some properties of two  $\alpha$ -glucosidases in glutinous rice seed. Denpun Kagaku 36 (1989) 181-187.
- [34] Takahashi N., Shimomura T., Chiba S., Studies on  $\alpha$ -glucosidase in rice. Part I. Isolation and some properties of  $\alpha$ -glucosidase I and  $\alpha$ -glucosidase II. Agric. Biol. Chem. 35 (1971) 2015-2024.
- [35] Yamasaki Y., Suzuki Y., Two forms of  $\alpha$ -glucosidase from rice seeds at the milky stage. Agric. Biol. Chem. 44 (1997) 707-715.
- [36] Eksittikul T., Svendsby O., Yamaguchi H., Iizuka M., Minamiura N., Thai rice seed  $\alpha$ -glucosidase and its specificity. Biosci. Biotechnol. Biochem. 57 (1993) 319-321.
- [37] International Rice Genome Sequencing Project. The map-based sequence of the rice genome. Nature 436 (2005) 793-800.
- [38] Ohyanagi H, Tanaka T, Sakai H, Shigemoto Y, Yamaguchi K, Habara T, Fujii Y, Antonio B.A., Nagamura Y., Imanishi T., Ikee K., Itoh T., Gojobori T., Sasaki T., The Rice Annotation Project Database (RAP-DB): hub for *Oryza sativa* ssp. japonica genome information. Nucleic Acids Res. 34 (2006) D741-D744.
- [39] Takahashi M., Shimomura T., Chiba S., Biochemical studies on buckwheat  $\alpha$ -glucosidase part III. Transglucosylation action of the enzyme and isolation of the reaction products. Agric. Biol. Chem. 33 (1969)1399-1410.
- [40] Chiba S., Kimura A., Kobori T., Sitoh K., Quantitative determination of disaccharides produced from soluble starch through transglucosylation of buckwheat  $\alpha$ -glucosidase. J. Jpn. Soc. Starch Sci. 32 (1985) 213-216.
- [41] Okuyama M., Mori H., Chiba S., Kimura A., Overexpression and characterization of two unknown proteins, YicI and YihQ, originated from *Escherichia coli*. Protein Expr. Purif. 37 (2004) 170-179.
- [42] Kimura A. Takewaki S., Matsui H., Kubota M., Chiba S., Allosteric properties, substrate

specificity, and subsite affinities of honeybee  $\alpha$ -glucosidase I. J. Biochem. 107 (1990) 762-768.

- [43] Roe J.H., Rice E.W., A photometric method for the determination of free pentoses in animal tissues. J. Biol. Chem. 173 (1948) 507-512.
- [44] Edwards M., Dea I.C., Bulpin P.V., Reid J.S., Xyloglucan (amyloid) mobilisation in the cotyledons of *Tropaeolum majus* L. seeds following germination. Planta 163 (1985) 133-140.
- [45] Bradford M.M., A rapid and sensitive method for the quantitation of microgram quantities of protein utilizing the principle of protein-dye binding. Anal. Biochem. 72 (1976) 248-254.
- [46] Dubois M., Gilles K.A., Hamilton J.K., Rebers P.A., Smith F., Colorimetric method for determination of sugars and related substrates. Anal. Chem. 28 (1956) 350-356.
- [47] Reisfeld R.A., Lewis U.J., Williams D.E., Disk electrophoresis of basic proteins and peptides on polyacrylamide gels. Nature 195 (1962) 281-283.
- [48] Laemmli U.K., Cleavage of structural proteins during the assembly of the head of bacteriophage T4. Nature 227 (1970) 680-681.
- [49] Hizukuri S., Osaki S., A rapid Smith-degradation for the determination of non-reducing, terminal residues of (1,4)- $\alpha$ -D-glucans. Carbohydr. Res. 63 (1978) 261-264.
- [50] Hizukuri S., Takeda Y., Yasuda M., Suzuki A., Multi-branched nature of amylose and the action of debranching enzymes. Carbohydr. Res. 94 (1981) 205-213.
- [51] Palmiter R.D., Magnesium precipitation of ribonucleoprotein complexes. Expedient techniques for the isolation of undergraded polysomes and messenger ribonucleic acid. Biochemistry 13 (1974) 3606-3615.
- [52] Murray M.G., Thompson W.F., Rapid isolation of high molecular weight plant DNA. Nucleic Acids Res. 8 (1980) 4321-4325.
- [53] Hoefsloot L.H., Hoogeveen-Westerveld M., Kroos M.A., van Beeumen J., Reuser A.J.J., Oostra, B.A., Primary structure and processing of lysosomal  $\alpha$ -glucosidase; homology with

the intestinal sucrase-isomaltase complex. *EMBO J.* 7 (1988) 1697-1704.

- [54] Hunziker W., Spiess M., Semenza G., Lodish H.F., The sucrase-isomaltase complex: primary structure, membrane-orientation, and evolution of a stalked, intrinsic brush border protein. *Cell* 18 (1986) 227-234.
- [55] Kimura A., Takata M., Sakai O., Matsui H., Takai N., Takayanagi T., Nishimura I., Uozumi T., Chiba S., Complete amino acid sequence of crystalline  $\alpha$ -glucosidase from *Aspergillus niger*. *Biosci. Biotechnol. Biochem.* 56 (1992) 1368-1370.
- [56] Nakamura A., Nishimura I., Yokoyama A., Lee D.G., Hidaka M., Masaki H., Kimura A., Chiba S., Uozumi T., Cloning and sequencing of an  $\alpha$ -glucosidase gene from *Aspergillus niger* and its expression in *A. nidulans*. *J. Biotechnol.* 53 (1997) 75-84.
- [57] Kashiwabara S., Azuma S., Tsuduki M., Suzuki Y., The primary structure of the subunit in *Bacillus thermoamyloliquefaciens* KP071 molecular weight 540,000 homohexameric  $\alpha$ -glucosidase II belonging to the glycosyl hydrolase family 31. *Biosci. Biotechnol. Biochem.* 64 (2000) 1379-1393.
- [58] Matsui H., Chiba S., Low molecular-activity  $\alpha$ -glucosidase from ungerminated rice seed. *Agric. Biol. Chem.* 52 (1988) 1859-1860.
- [59] Monroe J.D., Gough C.M., Chandler L.E., Loch C.M., Ferrante J.E., Wright P.W., Structure, properties, and tissue localization of apoplasmic  $\alpha$ -glucosidase in crucifers. *Plant Physiol.* 119 (1999) 385-397.
- [60] Ernst H.A., Lo Leggio L., Willemoes M., Leonard G., Blum P., Larsen S., Structure of the *Sulfolobus solfataricus*  $\alpha$ -glucosidase: Implications for domain conservation and substrate recognition in GH31. *J. Mol. Biol.* 358 (2006) 1106-1124.
- [61] Karrer E.E., Litts J.C., Rodriguez R.L., Differential expression of  $\alpha$ -amylase genes in germinating rice and barley seeds. *Plant Mol. Biol.* 16 (1991) 797-805.
- [62] Sampedro J., Sieiro C., Revilla G., Gonzalez-Villa T., Zarra I., Cloning and expression pattern of a gene encoding an  $\alpha$ -xylosidase active against xyloglucan oligosaccharides from *Arabidopsis*. *Plant Physiol.* 126 (2001) 910-920.

- [63] Crombie H.J., Chengappa S., Jarman C., Sidebottom C., Reid J.S., Molecular characterisation of a xyloglucan oligosaccharide-acting  $\alpha$ -D-xylosidase from nasturtium (*Tropaeolum majus* L.) cotyledons that resembles plant 'apoplastic'  $\alpha$ -D-glucosidases. *Planta* 214 (2002) 406-413.

## Legends for figures

Fig. 1. Purification of rice  $\alpha$ -glucosidases.

(A) Chromatography on a CM-Sepharose CL-6B column (pH 8.3). Sample volume, 50 ml; column size,  $\phi$  1.8 x 30 cm; flow rate, 18 ml/h; equilibrium, 25 mM sodium phosphate buffer (pH 8.3); elution, linear NaCl gradient (0-0.8 M); fraction volume, 8 ml (Nos. 1-30) and 2 ml (Nos. 31-113). The chromatogram in the inset is that of the non-absorbed fraction (Nos. 1-30). The open circles, solid circles, and solid squares show absorbance at 280 nm,  $\alpha$ -glucosidase activity (U/ml), and NaCl concentration, respectively. (B) CBB-stained native-PAGE gel. Lanes 1, 2, and 3 show ONG1 (12  $\mu$ g), ONG2-I (2  $\mu$ g), and ONG2-II (2  $\mu$ g), respectively. (C) Activity-stained native-PAGE gel. ONG2-I (2  $\mu$ g; lane 1) and ONG2-II (2  $\mu$ g; lane 2) were subjected to native-PAGE, followed by staining with 2 mM 4-methylumbelliferyl  $\alpha$ -D-glucoside in 0.1 M sodium acetate buffer (pH 4.0) at 37°C for 5 min. (D) SDS-PAGE of purified enzymes using 15% polyacrylamide gel. Lanes 1 and 2, protein standards: myosin (200 kDa), phosphorylase *b* (97.4 kDa), bovine serum albumin (68 kDa), ovalbumin (43 kDa), carbonic anhydrase (29 kDa),  $\beta$ -lactoglobulin (18.4 kDa), lysozyme (14.3 kDa), aprotinin (6.2 kDa), and insulin B chain (3 kDa); lane 3, ONG2-I (1  $\mu$ g); lane 4, ONG2-II (1  $\mu$ g).

Fig. 2. Binding and degrading abilities to rice starch granules by ONG2-I and ONG2-II.

(A) Binding ability. Open and solid squares show the percentages of ONG2-I and ONG2-II bound to starch granules, respectively. (B) Degrading activity. Open and solid squares show the amount of glucose ( $\mu$ g per 0.5 ml of reaction mixture) liberated from starch granules by ONG2-I and ONG2-II, respectively. Open circles show soluble sugar liberated from starch granules without enzyme (control).

Fig. 3.  $\alpha$ -Glucosidase and  $\alpha$ -xylosidase activities in ripening (A) and germinating (B) seeds.

Enzyme activities in dry seeds are depicted in 0 h of panel B. Ordinate represents the enzyme activity (U) per one rice seed (100 seeds for each assay). Solid circles and open squares show  $\alpha$ -glucosidase and  $\alpha$ -xylosidase activities, respectively.

Fig. 4. Nucleotide and deduced amino-acid sequences of *ong2* encoding ONG2-I and ONG2-II.

Numbers on the left and right sides designate the nucleotide and deduced amino-acid sequences, respectively. The nucleotide at position 28 represents the first base of the initial Met. The signal sequence is indicated by dots, the polyadenylation signal (AATAAA) is indicated by a double-underline, and sequences determined by Edman degradation and by in-gel digestion using MALDI-TOF MS are underlined in bold. The N-terminal sequences of the 88 kDa- and 6 kDa-peptides of ONG2-I and ONG2-II are in the boxes with the gray background. Potential glycosylation sites (Asn-X-Thr, Ser) are boxed. The probe sequence used for southern and northern blots is indicated by a wavy underline.

Fig. 5. Multiple sequence alignments of ONG1, 2, 3, and 4.

Multiple alignments were performed by Clustal W available in neutral network. The letters with the black background represent identical residues in the four sequences. The characters with the gray background show residues conserved in three sequences.

Fig. 6. Southern blots of  $\alpha$ -glucosidase genes in rice genomic DNA.

Genomic DNA (5  $\mu$ g/lane) was digested with *ApaI*, *NotI*, *PstI*, *HindIII*, *EcoRI*, *EcoRV*, *SmaI*, or *ClaI*, electrophoresed on agarose gels, transferred to nylon membranes, and hybridized with probes

specific to the ONG1 (A), ONG2 (B) ONG3 (C), and ONG4 (D) genes. Positions of  $\lambda$ -HindIII and  $\phi$ X174-HaeIII size markers are shown at the left.

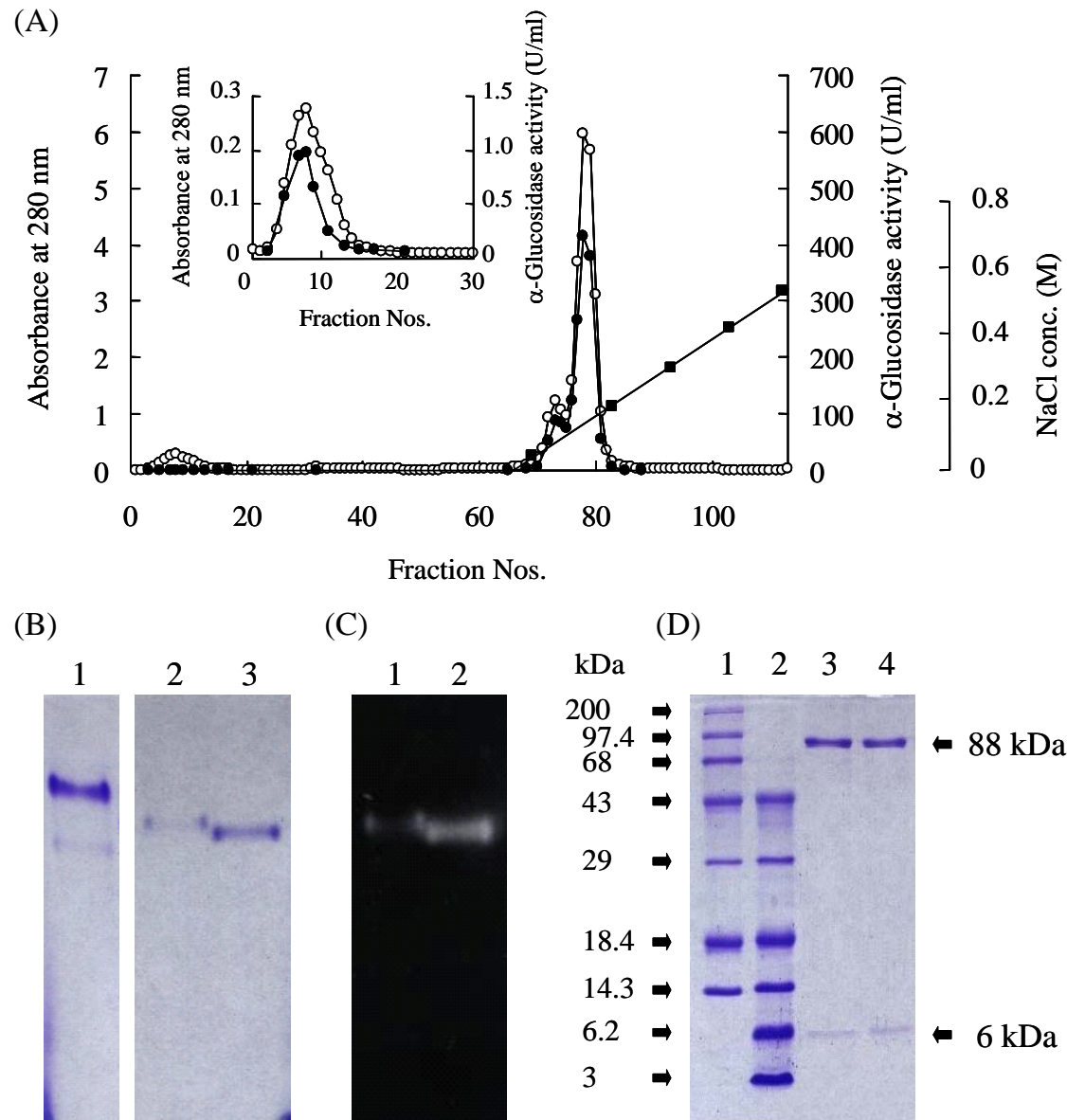
Fig. 7. Transcripts, mRNAs of ONG2 and ONG3, generated by alternative splicing of exon 1. The figure depicts using the rice genome sequence (<http://rgp.dna.affrc.jp>) [37]. The genomic sequences of ONG2 and ONG3 were identical, except for exon 1 (ONG2, open square; ONG3, black square).

Fig. 8. Northern blots of ONG mRNAs

Aliquots of total RNA (30  $\mu$ g/lane) from ripening seeds (A) and dry and germinating seeds (B) were electrophoresed on formaldehyde-agarose gels, blotted to nylon membranes, and hybridized with probes specific to each of the ONG mRNAs.

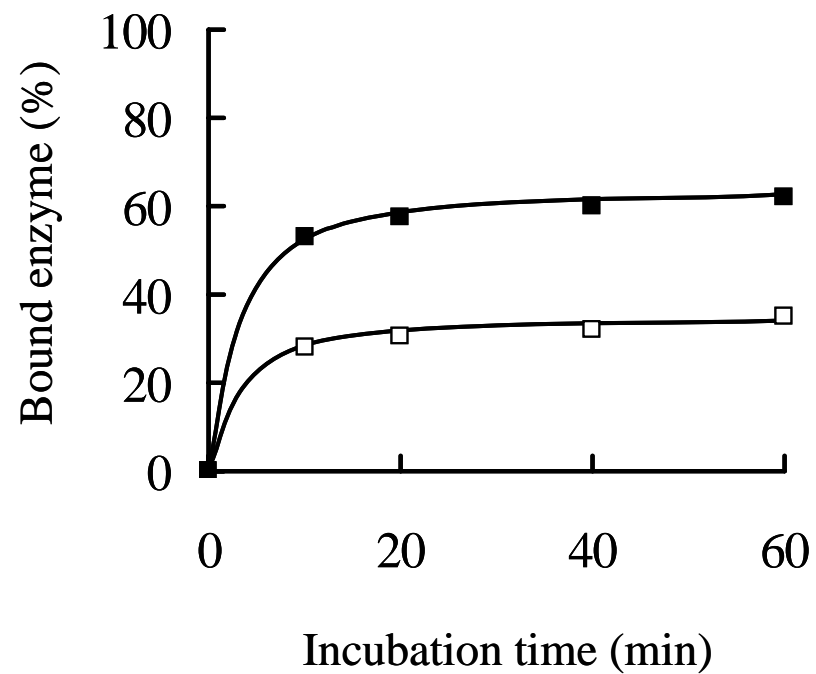
Fig. 9. Proteolytic cleavage site region of rice  $\alpha$ -glucosidases and N-terminal regions of plant  $\alpha$ -glucosidases.

(A) Precursor protein of ONG2-I and ONG2-II, including the 6 kDa-peptide (white box) and 88 kDa-peptide (black box). Narrow bars indicate the signal sequence (Met1-Cys33) and the possible removed sequence (ONG2-I, Val97-Ala112; ONG2-II, Val97-Leu122). (B) Sequences of plant  $\alpha$ -glucosidases relevant to the cleavage site region of rice  $\alpha$ -glucosidases. Sequences were aligned by Clustal W. Letters with a gray background show residues conserved in more than four sequences. The number in each sequence is counted from the initial Met.

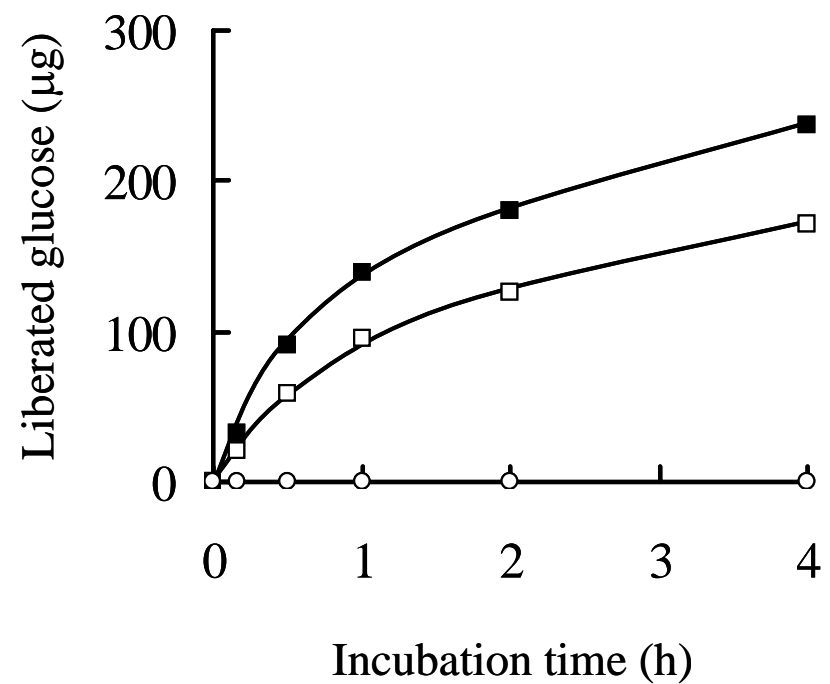


**Fig. 1** (Nakai, *et al*)

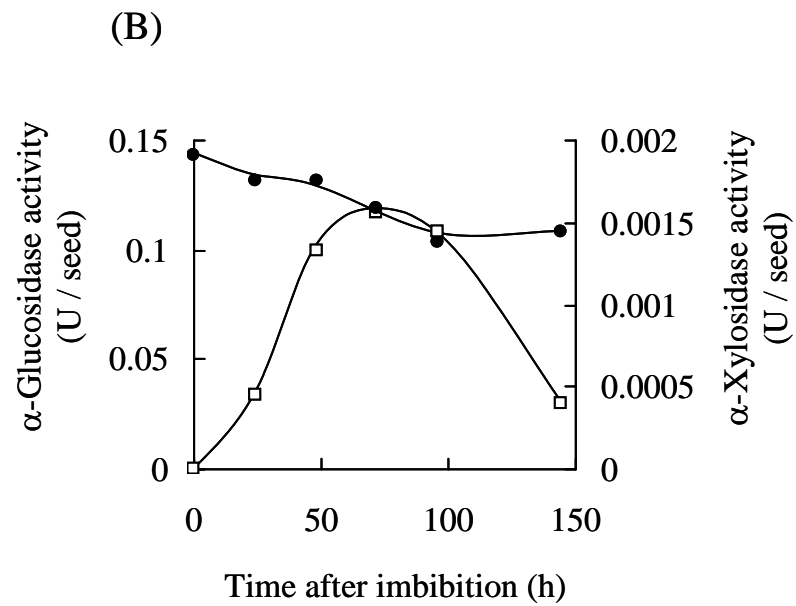
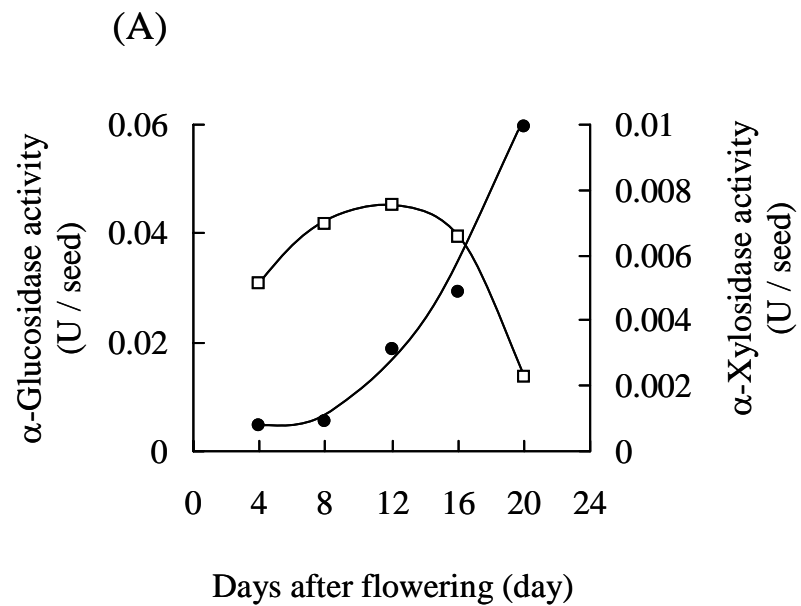
(A)



(B)



**Fig. 2** (Nakai, *et al*)



**Fig. 3** (Nakai, *et al*)



```

      *           20           *           40           *           60           *           80
ONG1 : -----MATRARPPLVLLCLCLASCLS-----SAIGGVSAANCYRTAFLVDEECRRLEAELAAVAGAGGGSTAAGDDVQRLDV : 76
ONG2 : -----MAGSPPAPPARRIG-ALAVFLLA-----LFLAPWGVDCCYNVASVAGSKNRLRARELAG---GGGGAAPELCPDVRRLSL : 73
ONG3 : -----MATRARPPLVLLCLCLFASSCLS-----CAVDAAAAANCYRTAFLVDEECRRLEAELVA---GGGGNTAGDDVQRLDV : 73
ONG4 : MREMLASLSSSSAAISCIPLCLLFLTLASSNGVFAAPPKVCSCYKLVSLVEHPECGALVGYLQV-----KQRTSTVCPDIPLLRL : 82

      *           100          *           120          *           140          *           160          *
ONG1 : YASLETDSRLHVRITDADADGPRWEVPQDVIPRPSPEFFLOTSRPGR-PVLSTATSDLTFAIHASSPFRFAVSRRSTGDVLFDTSP-NL : 161
ONG2 : TASLETDSRLHVRITDADADHPRWEVPQDVIPRPSPDSFLAATRPGGRVLSTATSDLTFAIHTS-PFRFTVVRRSTGDVLFDTSP-NL : 158
ONG3 : YASLETDSRLHVRITDADADHPRWEVPQDVIPRPSPDSFLAATRPGGRVLSTATSDLTFAIHTS-PFRFTVVRRSTGDVLFDTSP-NL : 158
ONG4 : YVKHETKDRIRVQITDADADKPRWEVPVNLLOREPAPPVTGGRITCVPFAAGEYPGELVFTYGRDPFFAVAHRKSSREALENTSCGAL : 169

      180          *           200          *           220          *           240          *           260
ONG1 : VFKDRYLELTSSLPPPGRASLYGLGEOTKR-TFRLORNDFFTLWNSDIAAGNVDLNLYGSHPFYMDVRSGGGG---AAHGVLLLSNSN : 244
ONG2 : VFKDRYLELTSSLPPPGRASLYGLGEOTKR-TFRLORNDFFTLWNSDIAAGNVDLNLYGSHPFYMDVRSGGGGGGAAHGVLLLSNSN : 244
ONG3 : VFKDRYLELTSSLPPPGRASLYGLGEOTKR-TFRLORNDFFTLWNSDIAAGNVDLNLYGSHPFYMDVRSGGGGGGAAHGVLLLSNSN : 244
ONG4 : VFKDQILEASTSLRP--DAALYGLGENTOPGGIRLRPNDPYTTYTDISAINLNTDLYGSHPVYDLRSRGGHG---VAHAVLLLSNSN : 252

      *           300          *           320          *           340
ONG1 : GMDVIYGGSYVTYKVIGGVLDFYFFAGPSPLAVDQYTQLIGRPAPMPYWSFGFHQCRYGYKNVSDLEGVVAGYAKARIPLDVIMWTD : 331
ONG2 : GMDVIYGGSYVTYKVIGGVLDFYFFAGPSPLAVDQYTQLIGRPAPMPYWSFGFHQCRYGYKNVSDLEGVVAGYAKARIPLDVIMWTD : 331
ONG3 : GMDVIYGGSYVTYKVIGGVLDFYFFAGPSPLAVDQYTQLIGRPAPMPYWSFGFHQCRYGYKNVSDLEGVVAGYAKARIPLDVIMWTD : 331
ONG4 : GMDVFYRGTSLTYKVIGGVLDFYFSGPTLAVDQYTSMIGRPAPMPYWAFGFHQCRYGYKNLSVVEGVVEGYRNAOIPLDVIMWTD : 339

      *           360          *           380          *           400          *           420          *
ONG1 : IDYMDAKDFTLDPANFPADLLRPFVDRLHRNGOKFVVILDPGISVNATYGFFIRALKEDIFLKWNSNYLGVVWPGNVSFPDFLNP : 418
ONG2 : IDYMDAYKDFTLDPVNFPADRMRPFVDRLHRNGOKFVVILDPGINVNTYGFFVRGMKQDIFLKWNSNYLGVVWPGNVSFPDFLNP : 418
ONG3 : IDYMDAYKDFTLDPVNFPADRMRPFVDRLHRNGOKFVVILDPGINVNTYGFFVRGMKQDIFLKWNSNYLGVVWPGNVSFPDFLNP : 418
ONG4 : DDHMDAAKDFTLDPVNFRPKLEFEDKIHAOGMKYVILDPGIAVNNTYGVYORGMQGDVFIKLDCKPVLAOWPPGVYFPDFLNP : 426

      440          *           460          *           480          *           500          *           520
ONG1 : RAAEFWAREIAAFRRTLPVDGLWIDMNEISNFVD-----PPP-----LNAIDDPPYRINNSGVRRPINNK : 478
ONG2 : RAAEFWAREIAAFRRTLPVDGLWIDMNEISNFVD-----PPP-----LNAIDDPPYRINNSGVRRPINNK : 478
ONG3 : RAAEFWAREIAAFRRTLPVDGLWIDMNEISNFVD-----PPP-----LNAIDDPPYRINNSGVRRPINNK : 478
ONG4 : NGVSWIDEVRREHDLVPVDGLWIDMNEASNFCTGKCEIPTHLCPLENTTTPWVCLDCKNLTNTRWDPPYKINASQTARLGFN : 513

      *           540          *           560          *           580          *           600
ONG1 : TVPASAVHYGGVAEYDAHNLFGFLEARATHDALLRDTGRRPFVLSRSTFVGSGRYTAHWTGDNFATWDDIRYSINTMLSFGLFGIPM : 565
ONG2 : TVPASAVHYGGVAEYDAHNLFGFLEARATHDALLRDTGRRPFVLSRSTFVGSGRYTAHWTGDNAATWEDLHYSINTMLSFGLFGIPM : 565
ONG3 : TVPASAVHYGGVAEYDAHNLFGFLEARATHDALLRDTGRRPFVLSRSTFVGSGRYTAHWTGDNAATWEDLHYSINTMLSFGLFGIPM : 565
ONG4 : IIATSATHYNGLLEYNAHSLYGFSOATATHOALQLOGQRPFTLIRSTFVGSGAYAHWTGDNKGIWENLRYSISTIMLNFGIFGMPM : 600

      *           620          *           640          *           660          *           680          *
ONG1 : IGADICGFGNTFEELCSRWIQLGAFYPFSRDHSAIGTVRRELYLWESVARSARKALGLRYRLLPYLTLMYEAHTTGAPIARPLFF : 652
ONG2 : IGADICGFGNTFEELCSRWIQLGAFYPFSRDHSAIGTVRRELYLWESVARSARKALGLRYRLLPYLTLMYEAHTTGAPIARPLFF : 652
ONG3 : IGADICGFGNTFEELCSRWIQLGAFYPFSRDHSAIGTVRRELYLWESVARSARKALGLRYRLLPYLTLMYEAHTTGAPIARPLFF : 652
ONG4 : VGADICGFYPQPFEELCNRWIELGAFYPFSRDHANFASPROELLYWESVAKSARNALGMRYRLLPYLTLNYOAHLTGAPVARPVF : 687

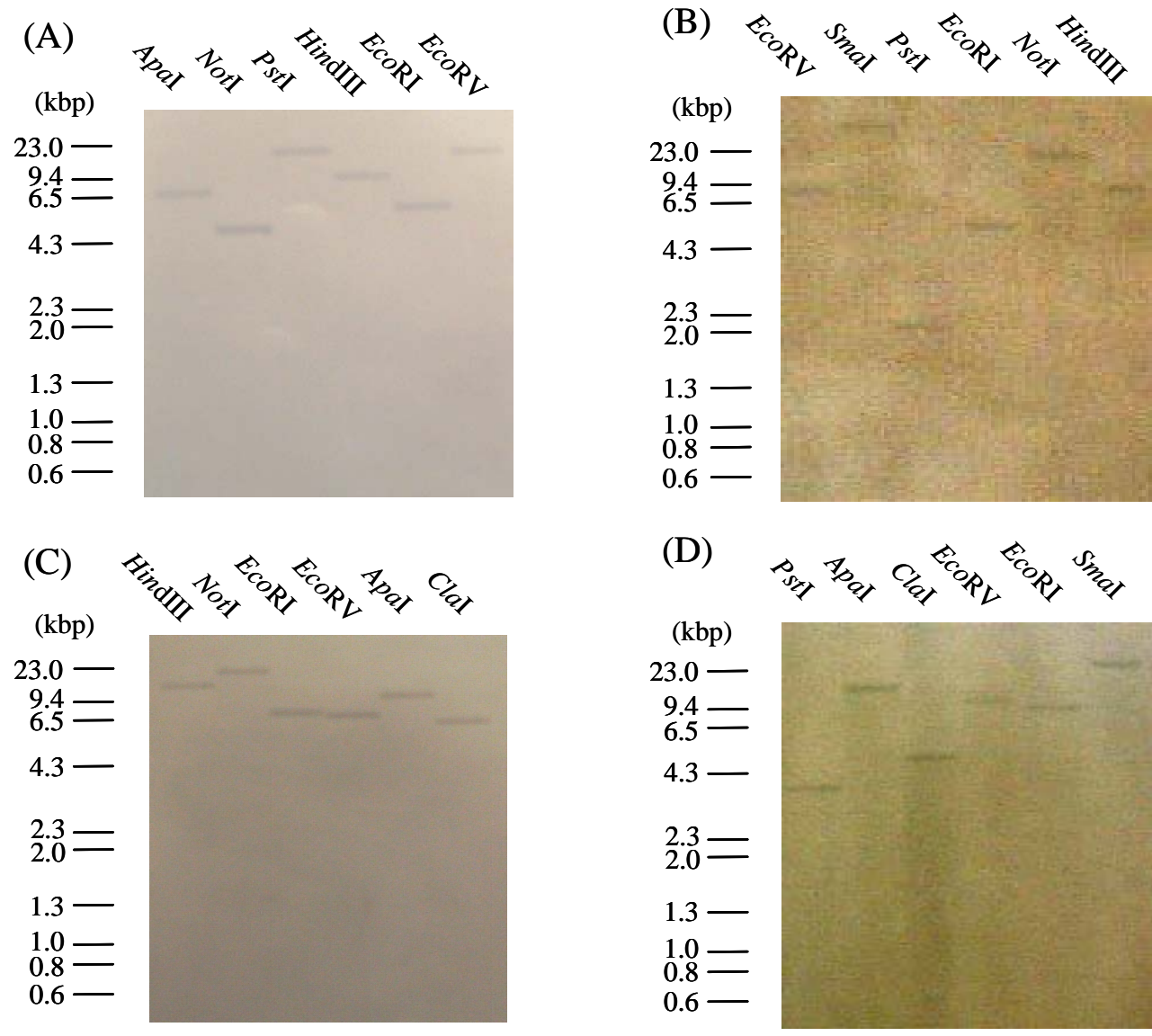
      700          *           720          *           740          *           760          *           780
ONG1 : SYPGDVATYGIDROFLLGRGVLVSPVLEPGATTVLAYFPAGRWFSLYDFSLAVATKTGKRVLLPADTVNVHVAGGNILLTLQOPAL : 739
ONG2 : SYPGDVETYGIDROFLLGRGVLVSPVLEPGATTVLAYFPAGRWFSLYDFSLAVATKTGKRVLLPADTVNVHVAGGNILLTLQOPAL : 739
ONG3 : SYPGDVETYGIDROFLLGRGVLVSPVLEPGATTVLAYFPAGRWFSLYDFSLAVATKTGKRVLLPADTVNVHVAGGNILLTLQOPAL : 739
ONG4 : SFPDFTPCYLGSTOYLLGASVMVSPVLEQATSVSAMFPPGSWNLFDITKVVSRGEGAVKLDAPLNEINVHVFONTLLPMORGGT : 774

      *           800          *           820          *           840          *           860          *
ONG1 : ISSRVRQSVVHLLVAL---AEDGTATGDLFIDDGESPEMVCARSRWSQIKFSGATESGGSVVRVRSHVHDSYAPSRTMVIAKVVLM : 823
ONG2 : ISSRVRQSVVHLLVAL---ADDGTATGDLFIDDGESPEMAGPRSRWSQIKFSGATESGGSVVRVRSHVHDSYAPSRTMAICKVVLM : 823
ONG3 : ISSRVRQSVVHLLVAL---ADDGTATGDLFIDDGESPEMAGPRSRWSQIKFSGATESGGSVVRVRSHVHDSYAPSRTMAICKVVLM : 823
ONG4 : ISKEARATPFTLVVAFPFGATEAEASGAVYVDDDSRPEMVLAEGQATVVRFYATVR--GKAVTVRSEVELGSYSLQKGLLLEKSVL : 859

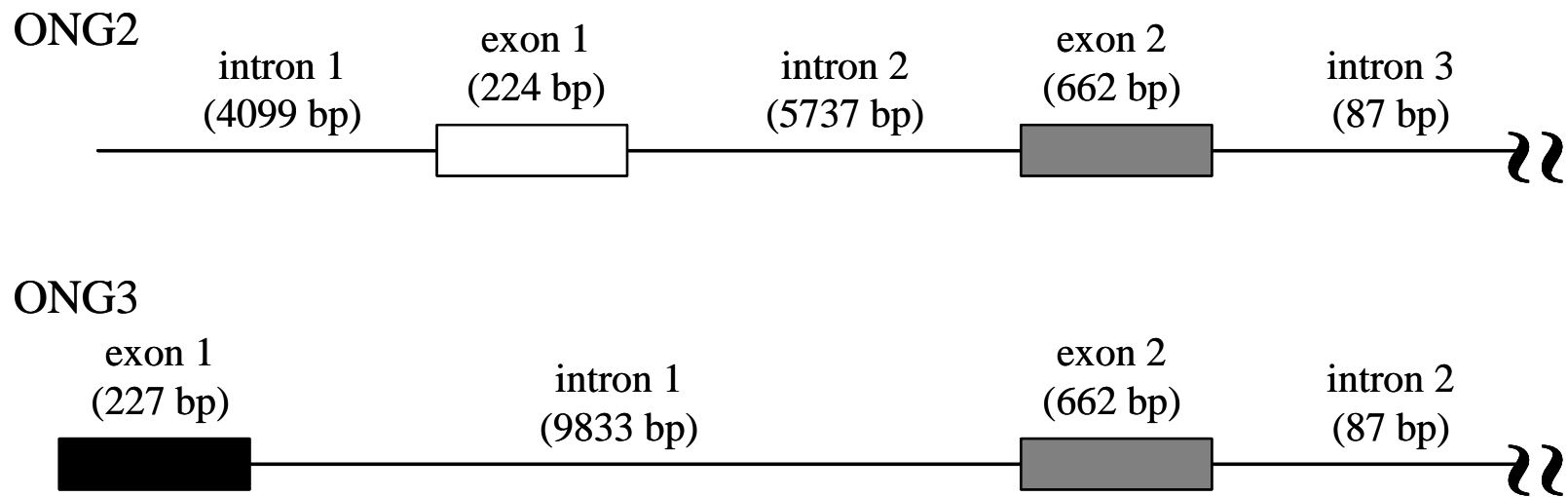
      880          *           900          *           920          *           940
ONG1 : GLRSPVPPKGFAVY-ANGVQVNASTAVDGCGGNPE--KGALG-----VAHVGLSLVVGQEFDLKVVMTY-- : 886
ONG2 : GLRSAAPPKGFAVY-ANGVQVNASTAV-GGAAGSPE--KGALG-----VAHVSGLLVVGQEFDLKVVMTY-- : 885
ONG3 : GLRSAAPPKGFAVY-ANGVQVNASTAV-GGAAGSPE--KGALG-----VAHVSGLLVVGQEFDLKVVMTY-- : 885
ONG4 : GLEGTGRDLAVHVDGANATAIATSRPYFAGAEALHGHRDVECHKKSVMVEVGLAPLCKSFIMTWNMQIEA : 932

```

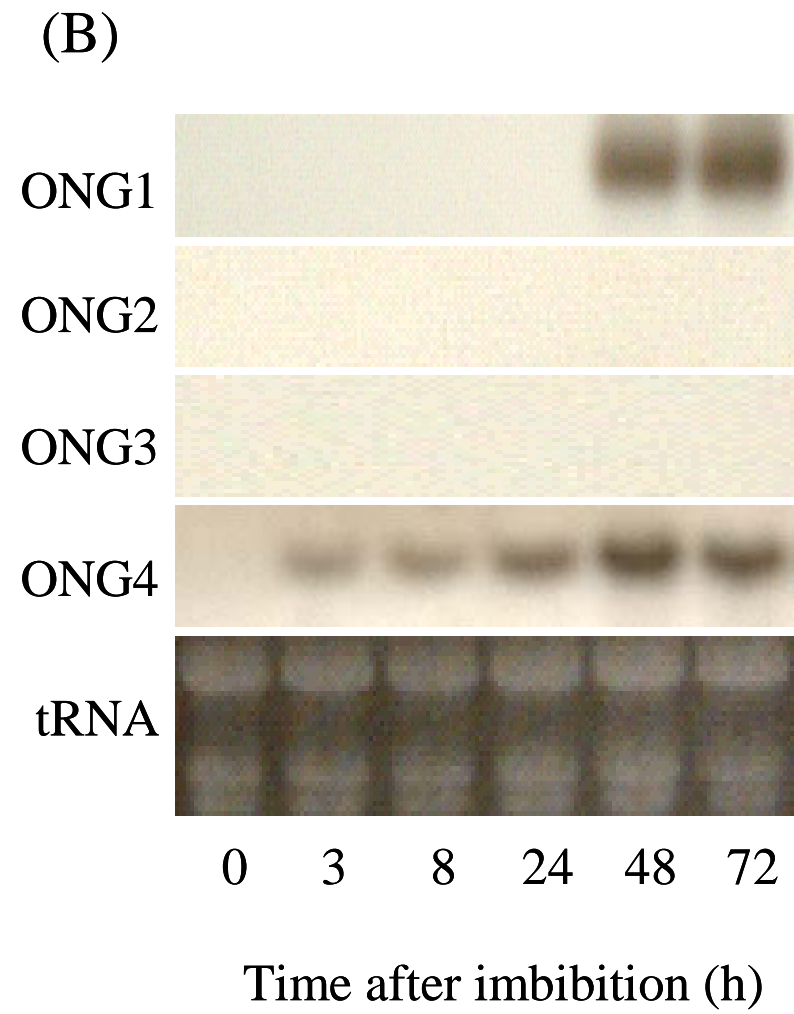
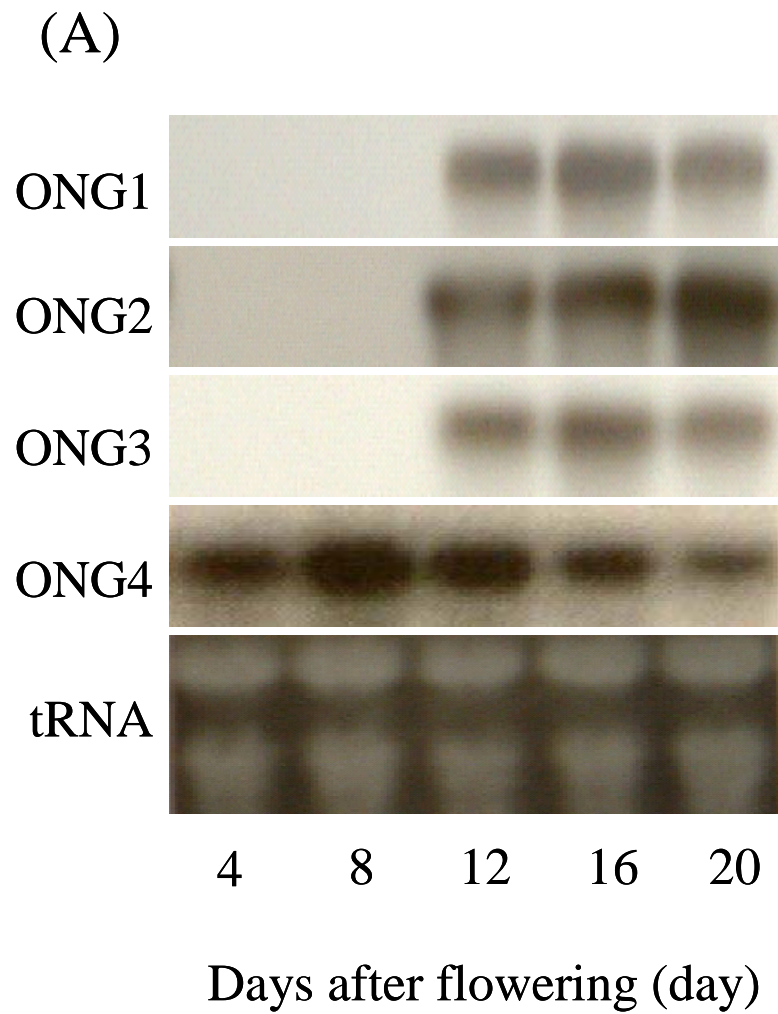
Fig. 5 (Nakai, *et al*)



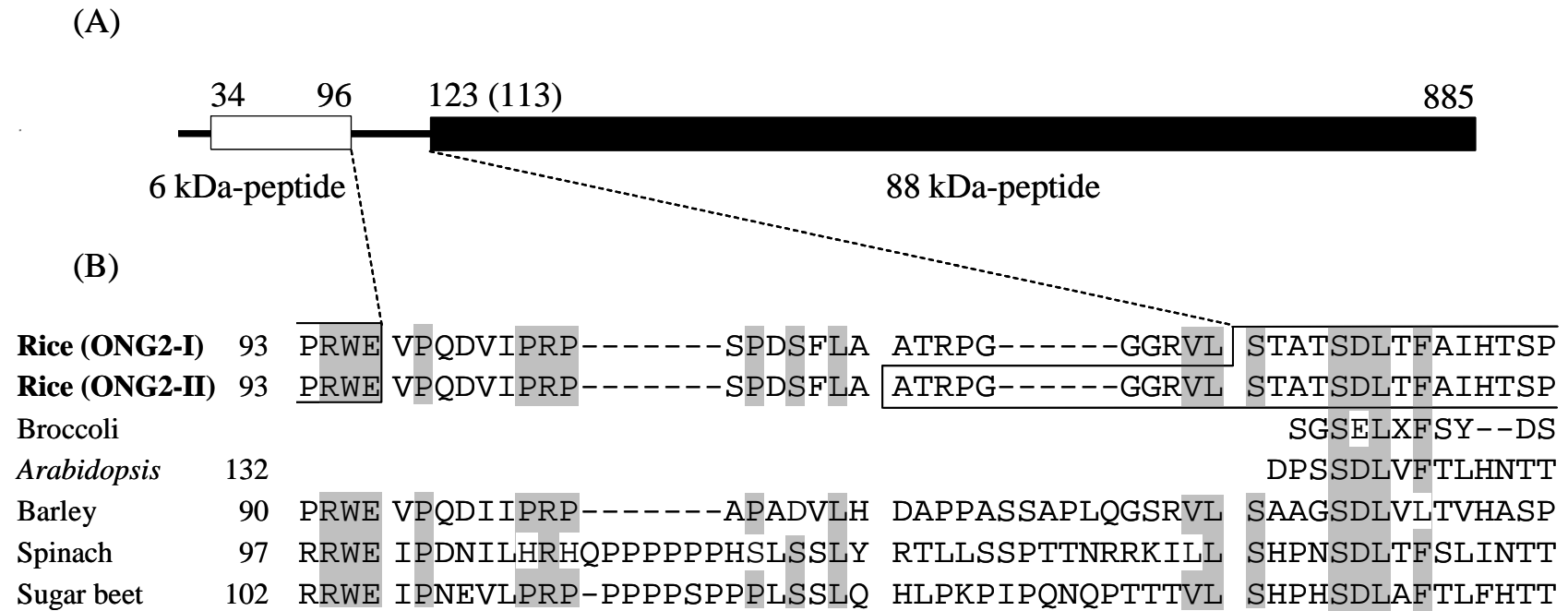
**Fig. 6** (Nakai, *et al*)



**Fig. 7** (Nakai, *et al*)



**Fig. 8** (Nakai, *et al*)



**Fig. 9 (Nakai, *et al*)**

Table 1  
Summary of purification of rice  $\alpha$ -glucosidases

Procedure	Total protein (mg)	Total activity (units)	Specific activity (units/mg)	Recovery (%)
Crude extract	9680 <sup>a</sup>	10000		100
Ammonium sulfate (70% satn.)	114000 <sup>b</sup>	9670	0.0848	96.7
Ammonium sulfate (20-50% satn.)	16400 <sup>b</sup>	9000	0.550	90.0
Dialysis against 50 mM sodium acetate buffer (pH 4.7)	4710 <sup>b</sup>	8930	1.90	89.3
CM-Sepharose CL-6B (pH 6.2)	411 <sup>b</sup>	8550	20.8	85.5
Sephadex G-100 (1st)	111 <sup>b</sup>	5080	45.8	50.8
$\alpha$ -Glucosidase 1				
CM-Sepharose CL-6B (pH 8.3) (1st)	22.8 <sup>b</sup>	35.9	1.57	0.359
Sephadex G-100 (2nd)	14.3 <sup>b</sup>	12.6	0.881	0.126
$\alpha$ -Glucosidase 2-I				
CM-Sepharose CL-6B (pH 8.3) (1st)	6.63 <sup>c</sup>	702	106	7.02
CM-Sepharose CL-6B (pH 8.3) (2nd)	5.36 <sup>c</sup>	592	110	5.92
Sephadex G-100 (2nd)	3.44 <sup>c</sup>	418	122	4.18
$\alpha$ -Glucosidase 2-II				
CM-Sepharose CL-6B (pH 8.3) (1st)	30.1 <sup>c</sup>	3200	106	32.0
CM-Sepharose CL-6B (pH 8.3) (2nd)	25.0 <sup>c</sup>	2790	111	27.9
Sephadex G-100 (2nd)	21.1 <sup>c</sup>	2620	124	26.2

<sup>a</sup> This value was estimated by Bradford method using BSA as standard.

<sup>b</sup> These values were calculated under the assumption that  $E_{1\text{cm},280\text{nm}}^{1\%}$  was 10.

<sup>c</sup> These values were calculated using  $E_{1\text{cm},280\text{nm}}^{1\%} = 16.3$  of purified protein.

Table 2  
Rate parameters for hydrolyses of various substrates by rice  $\alpha$ -glucosidase 2-I and 2-II

	$\alpha$ -Glucosidase 2-I			$\alpha$ -Glucosidase 2-II		
	$K_m^a$	$k_0^b$	$k_0/K_m^c$	$K_m^a$	$k_0^b$	$k_0/K_m^c$
Maltose	2.1	244	116	2.3	252	110
Maltotriose	1.6	331	207	1.9	357	188
Maltotetraose	2.0	313	157	2.4	313	131
Maltopentaose	1.7	348	205	1.8	357	198
Maltohexaose	1.0	339	339	1.3	339	261
Maltoheptaose	0.97	331	341	1.0	366	366
Kojibiose	1.2	58.0	48.3	1.1	60.9	55.4
Nigerose	3.0	313	104	3.5	348	99.5
Isomaltose	29	28.7	0.990	27	28.7	1.06
Phenyl $\alpha$ -glucoside	5.0	19.1	3.82	5.3	23.5	4.43
Soluble starch	1.2	348	290	1.1	331	301

<sup>a</sup> mM, <sup>b</sup> s<sup>-1</sup>, <sup>c</sup> mM<sup>-1</sup>·s<sup>-1</sup>.

Table 3  
N-Terminal amino acids sequences of rice  $\alpha$ -glucosidases

Peptide	N-terminal amino acid sequence
ONG2-I (6 kDa-peptide)	GYNVASVAGSKNRLRARLEL
ONG2-I (88 kDa-peptide)	STATSDLTFAIXTXP
ONG2-II (6 kDa-peptide)	GYNVASVAGSKNRLRARLEL
ONG2-II (88 kDa-peptide)	ATRPGGXRVLSTATSDLTF
ONG1 <sup>a</sup>	AFLVDEEGXXL

<sup>a</sup> Major band in lane 1 of Fig. 1B.

**Table 4**  
**MALDI-TOF MS analysis of peptide mixtures from in-gel tryptic digestion of 6 and 88 kDa-peptides of rice  $\alpha$ -glucosidase 2-I and 2-II**

No.	Mass measured		Mass calculated	Start residue	End residue	Sequence
	2-I	2-II				
1	785.5	NF <sup>a</sup>	785.5	45	50	NRLRAR
2	1,238.6	1,238.5	1,238.6	87	96	ITDADHPRWE
3	1,429.8	NF <sup>a</sup>	1,429.8	83	94	LHVRI TDADHPR
4	1,448.7	1,448.7	1,448.8	70	82	RLSLTASLETDSR
5	1,735.9	1,735.8	1,735.9	51	69	LELAGGGGGAPELGPDVR
6	706.4	706.4	706.4	427	432	EIAAFR
7	733.4	733.5	733.4	666	671	QFLLGR
8	848.5	848.5	848.5	621	627	ALGLRYR
9	850.4	850.4	850.4	420	426	AAEFWAR
10	852.5	852.5	852.5	360	366	LHRNGQK
11	1,223.6	1,223.6	1,223.6	787	799	FSGATESSGGGVVR
12	1,265.7	1,265.6	1,265.7	607	616	ELYLWESVAR
13	1,421.8	1,421.8	1,421.8	606	616	RELYLWESVAR
14	1,429.8	1,429.8	1,429.8	164	176	YLELTSSLPPPGR
15	1,484.8	1,484.8	1,484.8	585	596	WIQLGAFYPFSR
16	1,506.8	1,506.8	1,506.8	340	352	DFTLDPVNFADR
17	NF <sup>a</sup>	2,064.0	2,064.1	121	139	VLSTATSDLTFAIHTSPFR
18	2,302.4	2,302.2	2,302.2	672	694	GVLVSPVLEPGATTVTAYFPAGR
19	3,140.7	3,140.7	3,140.7	713	743	VTL P APADTVNVHVAGGNILTLQQPALTSSR

<sup>a</sup> Signal not found.