



HOKKAIDO UNIVERSITY

Title	Studies on Small Ice Crystals. III. ; Some Remarks on Replica Methods.
Author(s)	KOBAYASHI, Teisaku
Citation	Contributions from the Institute of Low Temperature Science, 8, 75-86
Issue Date	1955-07-30
Doc URL	https://hdl.handle.net/2115/20217
Type	departmental bulletin paper
File Information	8_p75-86.pdf



Studies on Small Ice Crystals. III.*

Some Remarks on Replica Methods.

by

Teisaku KOBAYASHI
*Meteorological Section, Institute of
Low Temperature Science.*
(Manuscript Received April 1955)

I. Introduction

Since V. J. SCHAEFER⁽¹⁾⁽²⁾⁽³⁾ devised a convenient technique for making permanent replicas of snowflakes, this has been adopted by many researchers of our country in laboratory as well as in field experiments. It may be indispensable especially for the statistical treatment of the artificial production of ice crystals.⁽⁴⁾⁽⁵⁾⁽⁶⁾ The replica, in which the nuclei (either freezing or condensation nuclei) are enclosed after water vapour has evaporated, can also be used for the direct observation of the nuclei under the electron-microscope.⁽⁷⁾⁽⁸⁾

The technique, in brief, consists in covering the frozen object with a cold dilute solution of an appropriate resin in a suitable solvent. After the solvent has evaporated, a very thin plastic film remains reproducing in minute detail all the surface features of the specimen. The substance of the original object is then removed by sublimation, after which the hollow shell of resin identical in appearance with the original object may be photographed and studied subsequently at any convenient time.

One to three parts of polyvinyl formal (Formvar) dissolved in 100 parts of ethylene dichloride originated by SCHAEFER is an excellent solution for making replicas of snowflakes, hoar frost and other ice crystals. Another suitable replica solution can be obtained by the use of Methalack,** as was found by T. SHIDEI.⁽⁹⁾

In spite of the wide utilization of the replica method, there seems to have been no critical discussion as to whether it reproduces the original form with complete fidelity. It may be worth calling attention to some criticisms offered at the international colloquium of experimental meteorology (Zürich, 4~6 October, 1954)⁽¹⁰⁾ on G. YAMAMOTO's report⁽¹¹⁾, in which it was claimed that cubic ice crystals were observed by replica method.

In this paper we shall deal with necessary precautions to be taken against replica methods, which are self-evident but are likely to be forgotten, in connection with some very interesting phenomena observed.

* Contribution No. 280 from the Institute of Low Temperature Science.

** Methacrylic acid ester resin to be obtained from Fuji-Kasei Co.

II. Observations

In the experiments at Asahikawa, 1954, the supercooled steam fog was seeded with AgI particles produced by the ground-based generator, and the precipitating ice crystals were caught every ten minutes on the glass plate covered with the Formvar solution at several stations distributed over the down-wind area. The replicas of ice crystals thus obtained were subsequently subjected to careful observation under the microscope for the examination of the crystal form as well as of the density on each plate. As shown in Photos. 1 and 2, the replicas make an exact impression of the surface structure of the original ice crystals, so that there seems no room for doubt as to the high fidelity of the replicas to the original, in so far as they are prepared under the best conditions.

During the period of our experiments, the air temperature varied from -16°C to -31°C , and we often found that in the Formvar solution there appeared white gelatinoid precipitation* which remained as residua with fibriform structure after the ethylene dichloride had completely evaporated. Photos. 3, 4, and 5 illustrate the residua deposited on the slide glass, Photo. 6 shows the residua that spoiled the fine replication of ice crystals. It is to be noticed that Photos. 2, 3 and 4 were taken from different portions of one and the same slide.

In later experiments carried out in our low temperature laboratory, we came across very interesting phenomena as described in the following:

(i) Some crystals resembling three-dimensional hexagonal crystals of snow were observed to be suspended near the surface of the bottled-up solution of Formvar (ca. 300 cc with 0.5% of Formvar) which had been left at the temperature of about -20°C for several days. When the solution was further cooled down, the gelatinoid precipitations appeared at the bottom.

The solution containing snow-like crystals was carefully poured into a shallow dish and the photographs were taken through a microscope (see Photos. 7 and 8).

In this connection, it is to be noted that, since we could not have a chance to get Formvar 15-95 (Shawinigan Prod. Corp. Shawinigan Falls, Ontario, Canada) as used by SCHAEFER, we made our experiments by making use of those which were offered by Mr. M. SHŌDA, by the Geophysical Section of Tōhoku University and by Kanto Chemical Co., among which the one offered by Mr. SHŌDA yielded the most excellent results for replica formation.

There were considerable differences among these materials in their physical properties such as swelling, solubility and viscosity, which may probably be due to the difference of the manufacturing process and consequently of the polymerization grade and of the kind of impurities. In so far as the segregation of crystals in their solutions is concerned, however, little difference was detected in their be-

* This phenomenon may be interpreted as the result of syneresis in the Formvar solution due to the lowering of temperature.

haviour.

(ii) A small quantity of the Formvar solution which contained these crystals was dripped softly onto the slide. After complete evaporation of the solvent they were permanently preserved as replicas which are shown in Photo. 9.

(iii) With a view to determining the temperature at which the crystals appear, the 0.5% Formvar solution filtrated at ordinary temperature and put in an uncovered Petri dish was transferred into the low temperature room, and gradually cooled down as it was under the microscope. Two slide glasses cleansed with cotton gauze were then put on the dish, in order that broken pieces of hoar frost formed around the cooling tubes at the ceiling might be prevented from falling into the solution by accident. The temperature of the solution was measured by means of a fine thermocouple and the reflection galvanometer with lamp-scale.

Now it was found that, as soon as the slide glasses, the temperature of which was the same as the air temperature (-22°C), were placed in position, the surface of the glasses was covered with the deposit of uniform "frost". The frost was composed of tiny crystals belonging to the needle type, as shown in Photos. 10 and 11. At the same time, it was observed that the crystals of the same type were suspended in the solution whose temperature was $-16^{\circ}\text{C} \sim -20^{\circ}\text{C}$ (Photo. 12). When the temperature of the solution was lower (and that only slightly lower: -21°C), the frost was found, what was remarkable, to consist of stellar and columnar type of crystals (Photo. 13).⁽¹²⁾

(iv) The slide glasses on which the "frost" had developed were enclosed in fresh Petri dishes and left for 24 hours in the appurtenant "air lock" between the low temperature room and the outside air. Much to our surprise, we found that the frost turned out to be a complete replica (see Photos. 14 and 15).

Close examination of this phenomenon revealed the fact that the slide glasses here used were those which had previously been coated with Formvar thin film for use in a separate experiment. It happened thus: Simultaneously with the "frost" formation on the glass surface, there condensed ethylene dichloride vapour in the form of liquid film (for its freezing point is -35°C), which then dissolved the Formvar with the result that the whole surface of the crystals was covered with the solution. Be that as it may, it is interesting and may be of some practical value that the replica of the "frost" can be obtained in this way (cf. Section III (3)).

(v) The glass bottle which contained ethylene dichloride half as much as its volume was brought into the low temperature room (about -25°C) and cooled down from the surroundings. On account of the considerable temperature difference established between the upper portion of the bottle and the bulk of ethylene dichloride, there appeared on the inside wall of the bottle isolated "spiral hoar" wetted with condensed ethylene dichloride. The same phenomenon was noted also in the bottle containing the Formvar solution (Photo. 16).

III. Methods to determine the nature of the crystalline substance

The observations described in the preceding section directly suggest that the snow-like or frost-like crystals obtained are nothing but the frozen water that has come from the impurity water in ethylene dichloride. Now the question is how to confirm this supposition. Investigations pursued with this object in view are as follows.

a) Melting point of the crystals formed in the Formvar solution.

When the 1% Formvar solution was maintained at -22°C , there appeared numerous tiny crystals near the surface, and gelatinoid precipitation at the bottom. Since the specific gravity of ethylene dichloride is 1.25 ($20\sim 4^{\circ}\text{C}$), it is to be asserted that the crystals suspended near the surface have a specific gravity less than 1.25. They have the shape quite different from the ordinary dendritic form, as illustrated in Photo. 17.

Now, in order to determine the melting temperature of the crystals, an electric heater controlled by an attenuator was set on the microscope stage (as shown in Fig. 1), and the solution was gradually heated from the bottom. The floating crystals, which were liable to adhere to the side wall of the dish as the result of the movement due to convection current, were caught in the field of the microscope. Measuring the temperature of the solution (T_s) by a fine thermometer, the wilting and melting process of these crystals was pursued by the aid of photomicrographs taken in succession (Photos. 18~20).

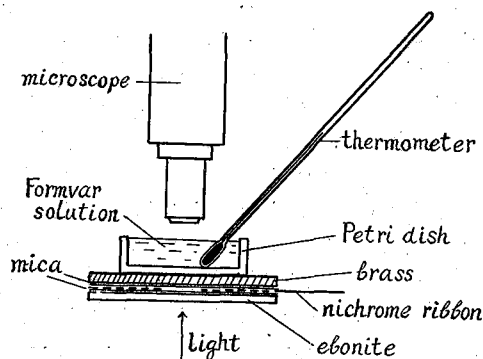

Fig. 1.

As T_s was raised, the crystals grew gaunt and suddenly melted to turn into spherical drops at the temperature of about -2.4°C . In another series of experiments the melting process was traced for the crystals picked up on the slide glass (Photos. 21~26). The melting point, as measured with a fine thermocouple, proved to be $+1.1^{\circ}\text{C}$.

If allowances are made for the accuracy of observations, these values may well be regarded as representing the melting point of ice.

b) Absorption test by phosphorus pentoxide.

A small quantity of phosphorus pentoxide was thrown into the Formvar solution, which was enclosed in Petri dish and contained a number of tiny crystals as shown in Photo. 17. After the lapse of 18 hours none of such crystals were observed in the solution, only there remained a small quantity of gelatinoid precipitation and a lump of phosphorus pentoxide that turned out dark brown. This affords additional proof that the crystals observed were formed of frozen water.

In such a solvent, phosphorus pentoxide reacts on water extremely slowly on account of the very small diffusion velocity of water molecules, so that the effect of the elevation of temperature T_s due to the heat of reaction will be negligible. Even if the disappearance of the crystals were caused by the elevation of T_s , the conclusion to be drawn would remain unchanged, because the generation of heat itself gives evidence for the occurrence of reaction between water and phosphorus pentoxide.

c) Measurement of the water content in ethylene dichloride and polyvinyl formal.

As it seemed desirable to know whether the ice crystals frozen out of the Formvar solution originate in the solute or in the solvent, we first measured the water content in the latter, ethylene dichloride. It is conceivable that the commercial product of ethylene dichloride may contain water as impurity, since it is able to dissolve about 0.5% of water at ordinary temperature. In order to ascertain this, we measured the increment of weight of a small absorption tube with phosphorus pentoxide in it, which had been left in a closed vessel containing a known amount of ethylene dichloride for a sufficiently long time (cf. Fig. 2).

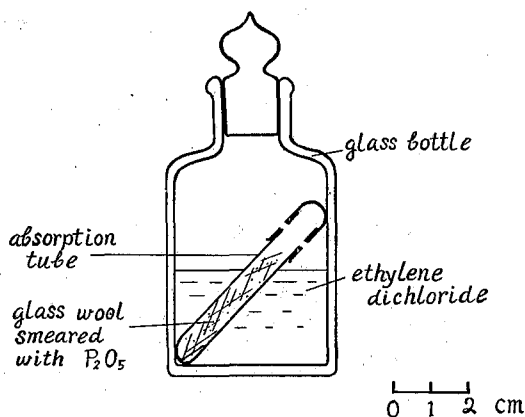

Fig. 2.

The results are given in Table I.

TABLE I.

Sample	Water content (Increment of the total mass of the tube after 8 days' desiccation)	Mass of ethylene dichloride	Impurity water (%)
1	34 mg	30 g	0.11
2	70 mg	30 g	0.23
3	29 mg	30 g	0.097

If it is permitted to assume that the suspended crystals are the excess of water frozen out of the solvent as the result of the diminution of solubility, the total weight of the crystals will be expected to be no more than a few per cent of the water content given in Table I. The observational results seem to be in accord with this expectation.

It may also be conceivable that the polyvinyl formal as well as other high polymers contains some water in absorbed or occluded state. To see if this actually is the case, a small tube containing a known quantity of polyvinyl formal was set in a vacuum desiccator alongside of phosphorus pentoxide and heated up to about 70°C (Fig. 3). The diminution of the total weight of the tube was carefully measured after thorough desiccation, with the result given in Table II.

Thus it may safely be asserted that the water content in polyvinyl formal is negligibly small. Even if this were not

TABLE II.

No. of sampling tube	Polyvinyl formal	Diminution of weight
1	0.1437 g	-0.0000 g
2	0.1301 g	0.0004 g
3	0.1256 g	-0.0001 g

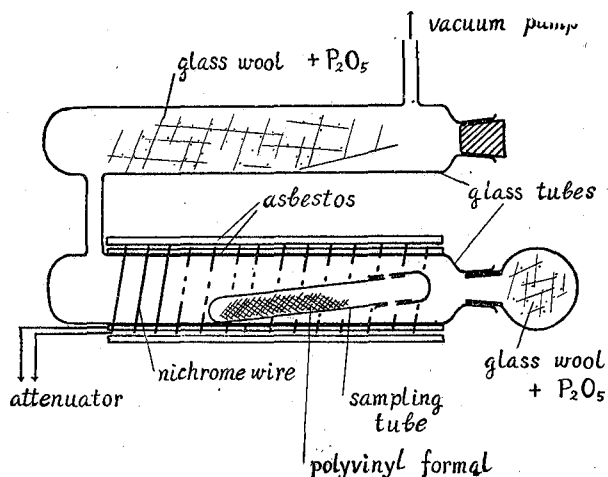

Fig. 3.

the case, this result shows that it is practically impossible to expel moisture from polyvinyl formal.

To sum up, it is to be concluded that the snow-like or frost-like crystals in question are none other than the crystals of ice.

d) Comparison with the Formvar solution dehydrated with P_2O_5 .

60 g of ethylene dichloride and 0.5 g of polyvinyl formal, both carefully treated with the dehydration processes described in the foregoing articles, were mixed in a sealed bottle and heated up to about 70°C , whereby polyvinyl formal was completely dissolved in ethylene dichloride and a transparent solution was obtained. Let this solution be designated as sample A. Then, another solution was prepared, which had the same concentration (0.84%) as A but differed from A in that the solvent was non-dehydrated. Let this solution be called sample B.

These two samples were placed in the room maintained at the temperature -22°C . After 16 hours, there occurred no change in sample A, while many assemblages of ice crystals like cotton-fibre were found to be suspended in sample B. Even when they were transferred to the room maintained at -31°C and left there for 5 hours, no trace of ice crystals was detected in sample A, only it turned out imperceptibly milk-white.

Thus it was again confirmed that the crystals formed in the Formvar solution are nothing but ice crystals, and also that the dehydration by P_2O_5 is essential for the preparation of replica solution.

After a drop of solution of sample B, in which ice crystals were formed, was dripped on a slide, or they were picked up by a forceps from the bottle onto a slide, their photomicrographs were taken with the aid of the apparatus shown in Fig. 4.

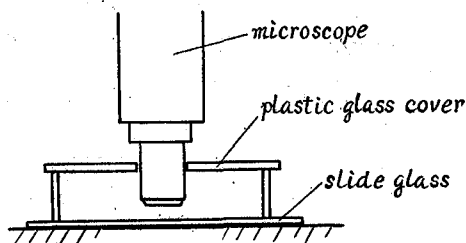

Fig. 4.

Notwithstanding their rather unusual forms, there is no doubt but that they are ice crystals, inasmuch as they melt at 0°C while turning into round drops. It is now being attempted to investigate the mode of ice crystal formation in high polymer solution such as Formvar. Here only the trial classification of crystal forms will be given with reference to the non-dehydrated 0.84% Formvar solution:

1) Dendritic plane form.

a) Octagonally branched: Eight branches with twigs radiate from the center.

Among the modifications of this form, the ones lacking one of the branches are frequently observed (Photo. 27). The one lacking two symmetrical branches may also belong to this type (Photo. 28).

b) Cruciform: Photo. 28 shows a nice example of this type.

c) Hexagonally branched: In the Formvar solution this belongs to a rather rare case (Photos. 28. and 29).

2) Dendritic solid form.

This sort of crystals has dendritic branches projecting into space from the center. Those which are most usually observed belong to this type. Photos. 30, 31 and 32 show examples of these crystals and their assemblage.

3) Single isolated branch.

From the branch there grow twigs perpendicularly in all directions (Photo. 33).

4) "Whiskers".

Complicated assemblage of whiskers which originate from the tip or the like of the dendritic crystal and extraordinarily extend into the solution (Photos. 34 and 35). The fine end of the whisker is occasionally seen to be curled, and the thicker portion near the root has tiny twigs as a rule (Photos. 36 and 37).

5) Hexagonal column.

Minute hexagonal columns are also seen to be interspersed among other crystals (Photos. 38 and 39).

6) Needle.

This sort of crystal is observed only on rare occasions (Photo. 40).

IV. Ice crystal formation in organic solvents which can dissolve water only in a small quantity

Since ethylene dichloride can dissolve 0.5% of water at 20°C, the ethylene dichloride commercially available, even that labeled as "extra pure", may still contain water as impurity. When it is cooled down, its solubility for water will decrease, and consequently become saturated with water. The water in excess of saturation will be spontaneously crystallized, provided the temperature at water saturation is sufficiently lower than the freezing point. In most cases of our experiments, such crystallization occurred between -10°C and -20°C, and it seems that the less the original content of water, the lower becomes the temperature at which the spontaneous crystallization takes place.

Similar phenomenon is expected to be observed not only for the ethylene dichloride but also for other organic solvents, in which water is soluble only to a small extent.

Conversely, if the ice crystals suspended in such solvents be warmed up sufficiently slowly, they will become "sublimated" by molecular diffusion into the solvent,

while, if the temperature be raised relatively rapidly up to 0°C, they will be liquefied to form spherical drops before they will diffuse into the solvent, which must be a considerably slow process.

(1) Ice crystals formed in ethylene dichloride.

Ethylene dichloride, which had been kept in the low temperature room and in which numerous tiny crystals had appeared, was poured into an open dish and set under the microscope.

The crystals floating near the surface are apt to flock together or adhere to the wall of the dish, which is partly caused by the elevation of the liquid temperature due to the use of high power illuminator. Photo. 41 shows the needle crystals formed at -24°C which is of the same crystal form as observed in Formvar solution at -20°C (cf. Photo. 12), and Photos. 42 and 43 illustrate the assemblage with fine fibriform structure which was obtained at -16°C. The snow-like crystals as was observed in Formvar solution have not yet been obtained.

(2) Hoar crystals formed in the presence of ethylene dichloride.

The Petri dish containing ethylene dichloride was covered with clean glasses previously chilled down to -32°C, when there instantly appeared many isolated hoar crystals surrounded by numerous tiny droplets (Photo. 44). The tiny droplets are without doubt due to the condensation of the vapour of ethylene dichloride, whose freezing point is -35°C.

The form of ice crystal may suffer a marked deformation when coexistent with ethylene dichloride vapour, as will be anticipated from NAKAYA'S observation⁽¹³⁾ concerning the growth of window hoar under the influence of alcohol vapour. In fact, the crystal forms observed throughout this experiment were so strange that they were, so to say, something like birds spreading their wings (Photos. 44 and 45) or the irregular assemblage composed of columnar crystals (Photo. 46) or of "spinal columns" (Photo. 47). Photos. 44 and 45 show two stages of the growing process, the former being taken after a few minutes from the start, and the latter after one hour and a half. It may be noticed that the "bird-wings" in Photo. 45 are likewise composed of irregular assemblage of columnar crystals.

When the slide was turned over, the drops of ethylene dichloride disappeared in a short while leaving the hoar crystals behind. After complete evaporation of the drops, the melting process of the crystals was examined under the microscope, while the slide, to the surface of which a thermocouple was attached, was heated at the rate of 0.5°C/sec. Photos. 48~50 are the typical illustration of the process:

Photo. 48: Immediately after the slide was turned over (-29.7°C).

Photo. 49: Shortly after the start of heating. Sublimation is in process.

Photo. 50: The moment crystals have melted (+1.1°C).

(3) Crystal formation on the polyvinyl formal in the presence of ethylene dichloride (A new replica technique).

A slide glass previously coated with the Formvar thin film was placed over the ethylene dichloride with the coated surface downwards, and at the same time, just for the sake of critical comparison, a clean glass was also put to the same test. The hoar crystals obtained in the same manner as described above are exemplified in Photos. 51~54, in which Photos. 51~53 belong to those formed on the coated surface and Photo. 54 to those on the clean glass.

After the ethylene dichloride has completely evaporated, both slides were put in a desiccator containing CaCl_2 and left in a cold chamber for 24 hours. Then it was found that the crystals formed on the polyvinyl formal surface turned out to be complete replicas, but nothing was left on the surface of the clean glass. Photos. 55 and 56 show the replicas of hoar crystals thus obtained corresponding to Photos. 51 and 52.

The possibility of a new replica technique, as already suggested in section II (iv), has now been demonstrated. This is especially suited for making replicas of tiny ice crystals, for we have only to coat the glass surface with Formvar thin film and, after the ice crystals or snowflakes are caught on it, put it in a small chamber filled with ethylene dichloride vapour maintained at the temperature below 0°C . The vapour of ethylene dichloride will instantly condense on the thin film, dissolve the Formvar, and cover the ice surface with excellent fidelity, the mechanical injury to the delicate crystalline structure such as might be caused by the dripping of Formvar solution being safely avoided.

(4) Crystal formation in chloroform.

Chloroform dissolves 0.15% of water at 22°C , and its freezing point is as low as -65°C . It may therefore be expected that the formation of ice crystals will occur in chloroform much in the same way as in ethylene dichloride. As a matter of fact, some flower-like crystals were observed blooming in the chloroform maintained at about -30°C .

They were transferred into a Petri dish and their photomicrographs were taken, while being gradually heated up to their melting point. Photos. 57 and 58 show the examples of such crystals adhering to the wall (at -19.5°C). With the rise of temperature they became thinner and thinner but still kept their crystal form at -0.3°C . Immediately thereafter however they suddenly disappeared, when the temperature was $+0.3^\circ\text{C}$, as measured with a fine thermocouple.

V. Conclusion

From the observational facts fully described above, we can draw the following conclusions as to the influence of impurity water in the Formvar solution on its replica process:

When the Formvar solution is used at the temperatures lower than ca. -10°C , e. g. for the observation of diamond dust in cold weather or of tiny ice crystals

artificially produced in a cold box, the impurity water will continue to crystallize out of the solution until the solvent will completely be evaporated, and exert an unfavourable influence upon the observation and identification of the crystals under investigation.

The influence might be negligible for the observation of larger snow crystals observable at relatively high temperatures near 0°C, as was the case with SCHAEFER'S observation. But, even in such a case, the impurity water more or less contained in replica solution will acquire some importance, provided a quantitative investigation as regards the ice crystal formation is required.

Thus we arrive at the final conclusion that it is absolutely necessary for the replica solution to be completely dehydrated e. g. by the use of phosphorus pentoxide.

Addenda

The Methalack and its thinner which can be used as a suitable resin for snow replication were also put to the same test, and it was found that at the temperatures below ca. -22°C there appeared ice crystals, and besides a particular kind of crystals having the form of nice tetrahedron bipyramid (Photos. 59 and 60). After dehydration by the use of P₂O₅, the former disappeared, while the latter still remained, only with considerable deformation in shape. Furthermore, no rising of temperature was observed when the latter was treated with sulphuric acid. So far nothing is known about this particular kind of crystalline substance.

Acknowledgments

The author takes this opportunity to express his thanks to Prof. S. KINUMAKI, the Chemical Research Institute of Non-Aqueous Solutions, Tōhoku University, for his kind advices. Many thanks are also due to Prof. T. HORI, Dr. D. KUROIWA and the members of the Institute of Low Temperature Science who took interest in this research and joined in the discussion with the author. This research was aided by grants from the Hokkaido Electric Power Co., for which the author also wishes to express his gratitude.

References

- (1) SCHAEFER, V. J. 1941 A Method for Making Snowflake Replicas. *Science*, **93**, 239~240.
- (2) SCHAEFER, V. J. 1942 Use of Snowflake Replicas for Studying Winter Storms. *Nature*, **149**, 81.
- (3) SCHAEFER, V. J. 1951 Compendium of Meteorology. American Meteorological Society, Boston, Massachusetts, 221~222.
- (4) ŌKITA, T. and K. KIMURA 1954 Ice Crystal Growth in the Atmosphere. *Journ. Met. Soc. Japan*, **32**, 11~24.

- (5) KOBAYASHI, T. 1954 The Ice Crystals of Rectangular Plane Form. *Contri. Insti. Low Temp. Sci.*, No. 5.
 - (6) MASON, B. J. 1953 The Growth of Ice Crystals in a Supercooled Water Cloud. *Quart. J. R. Met. Soc.*, 79, 104~111.
 - (7) ISONO, K. 1953 An Electron-Microscope Study of Ice Crystal Formation. *Journ. Met. Soc. Japan*, 31, 318~322.
 - (8) ITŌ, K and H. MARUYAMA 1954 An Electron-Microscope Study of Silver Iodide. Published for the Committees for Rain-Making in Japan (in Japanese).
 - (9) SHIDEI, T. 1951 Replication of Snow. *Journ. Japan Soc. Snow & Ice*, 13, 20~22 (in Japanese).
 - (10) DESSENS, H. 1954 *Comptes Rendus de Deux Congres Internationaux. Bull. Obs. Puy de Dôme*, 3, 81.
 - (11) YAMAMOTO, G., A. MIURA and T. OHTAKE Unpublished.
 - (12) KOBAYASHI, T. 1954 On the Ice Crystals Formed on the Hydrophobic Substances; A General Survey. *Contri. Insti. Low Temp. Sci.*, No. 6.
 - (13) NAKAYA, U., M. HANAZIMA and K. DEZUNO 1939 Experimental Researches on Window Hoar Crystals, a General Survey. *Journ. Fac. Sci. Hokkaido Univ.*, II, 3, 1~14.
-

1

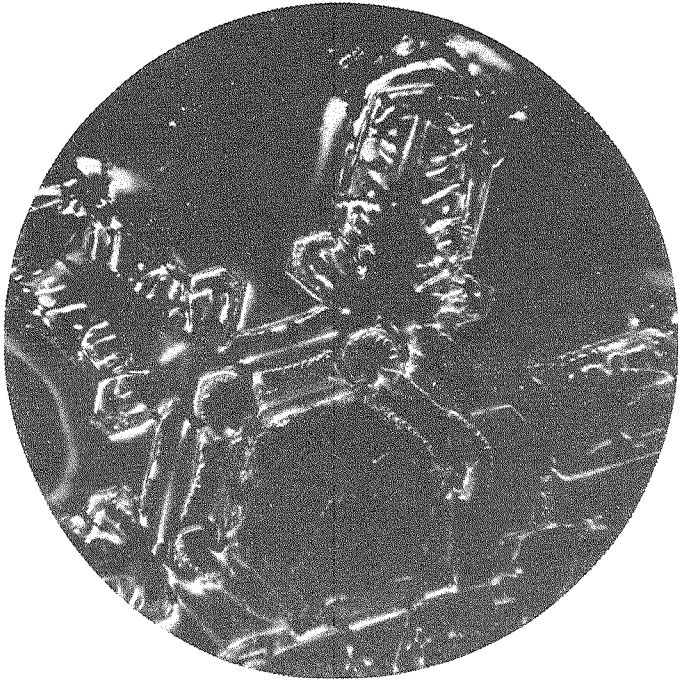

× 394

2

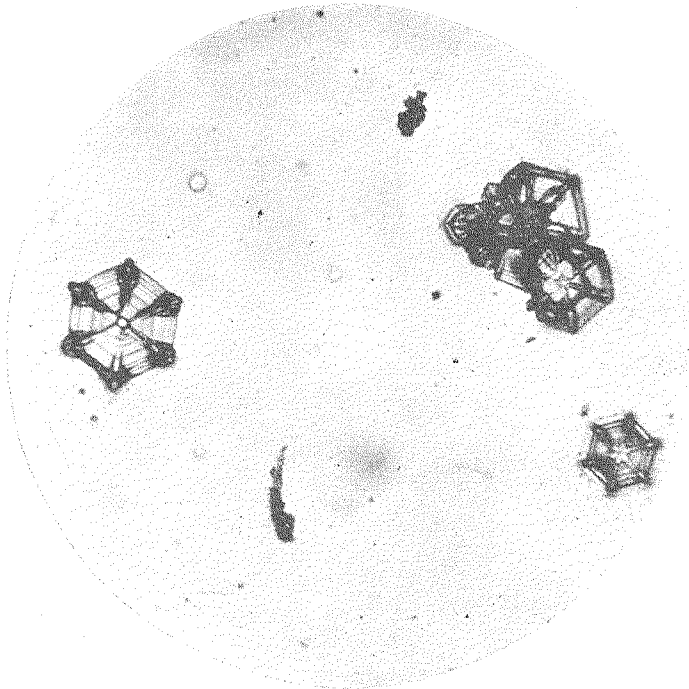

× 98

3

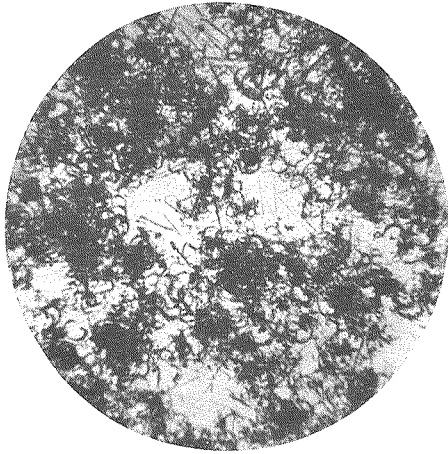

× 27

6

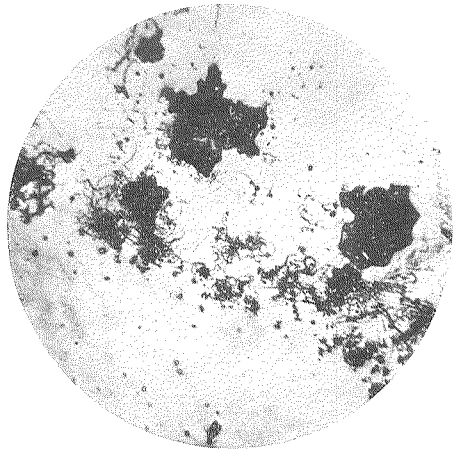

× 27

4

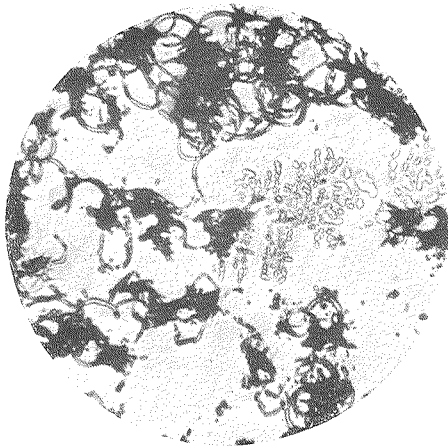

× 100

7



× 25

5

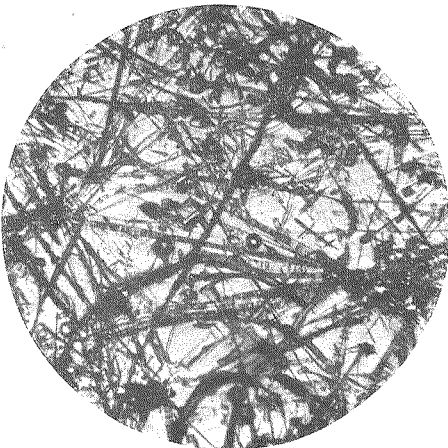

× 100

8

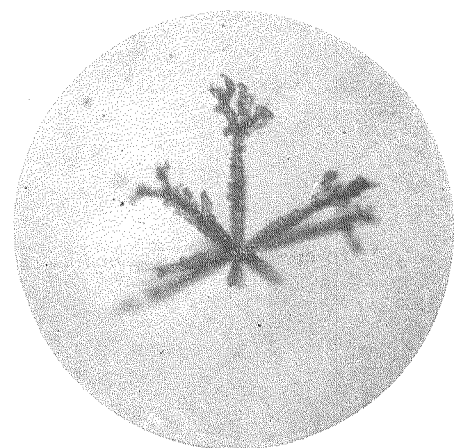

× 40

9

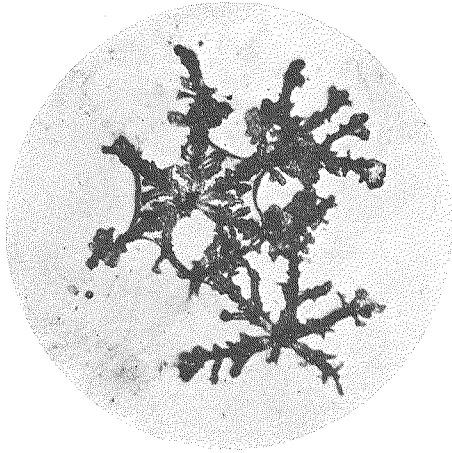

× 25

12



× 25

10

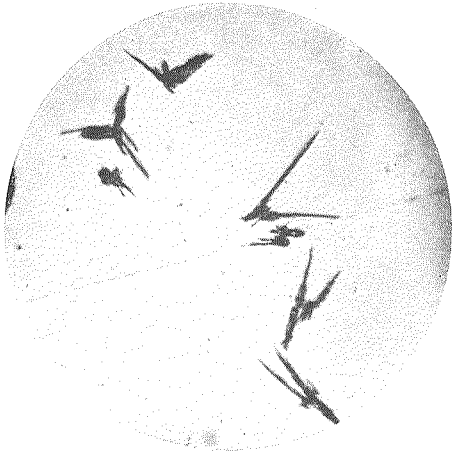

× 25

13

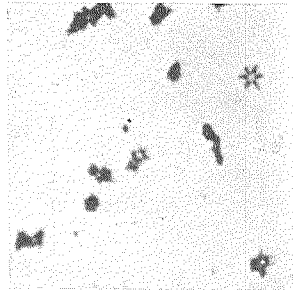

× 54

11

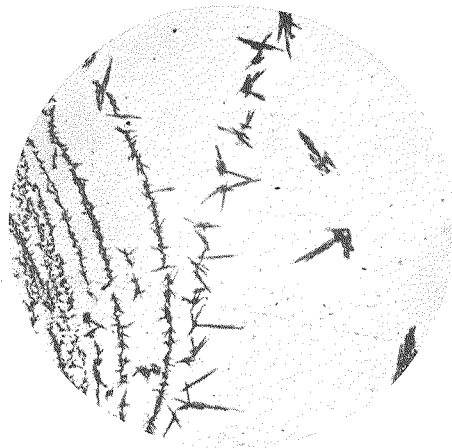

× 25

14

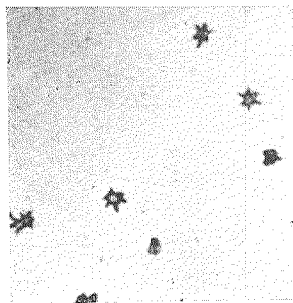

× 60

15

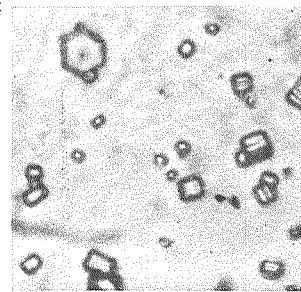

× 580

16

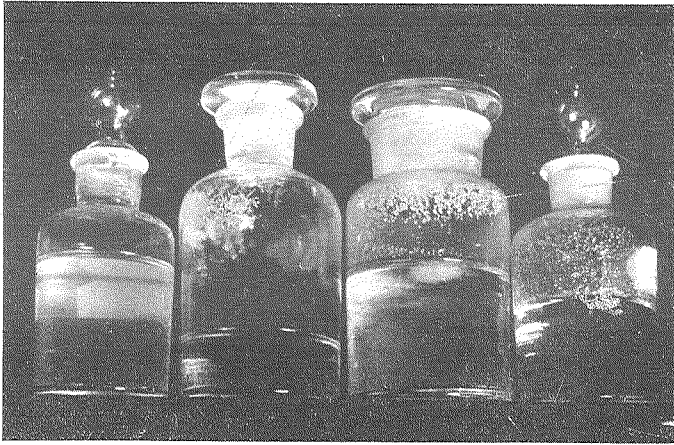

The first from left;
0.84% Formvar solution
dehydrated.

The second;
Ethylene dichloride.

The third;
0.1% Formvar solution,
where the suspended ice
crystals and the gelati-
noid precipitation are
also noticed.

The right end;
Chloroform.

17

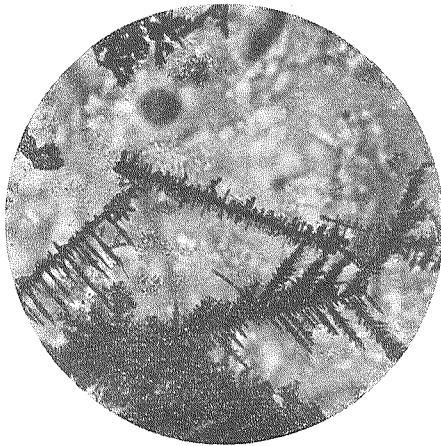

× 25

19

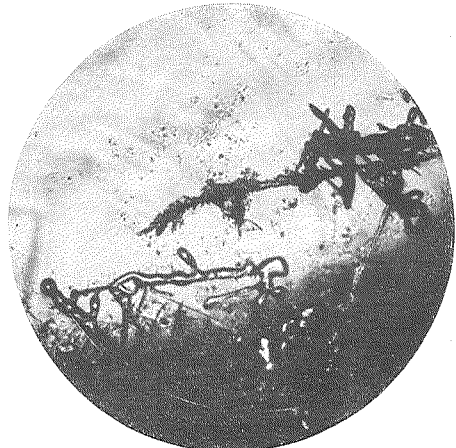

Temp. -11°C × 30

18

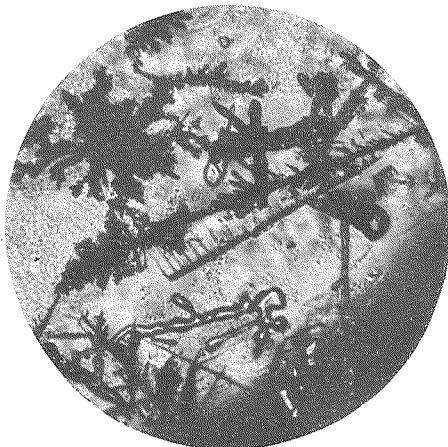

Temp. -19°C × 30

20

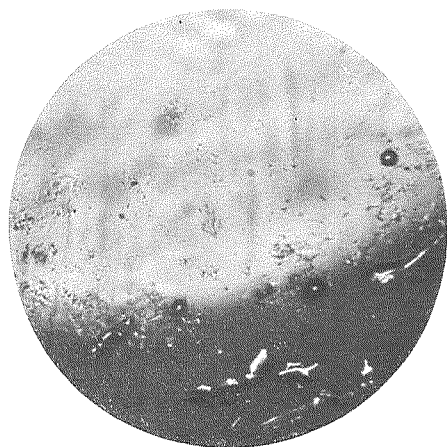

Temp. -24°C × 30

21



Temp. -29.4°C $\times 60$

24



Temp. -5.8°C $\times 60$

22

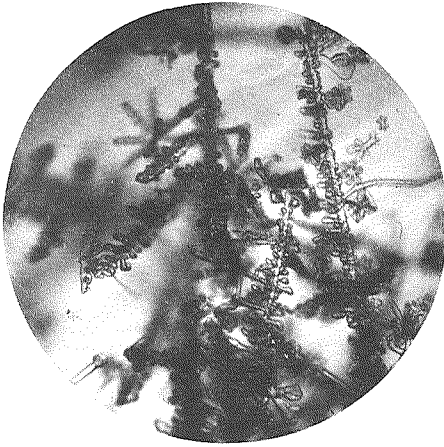

Temp. -19.8°C $\times 60$

25

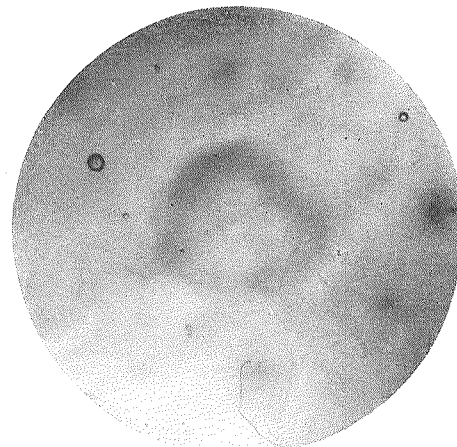

Temp. $+0.6^{\circ}\text{C}$ $\times 60$

23

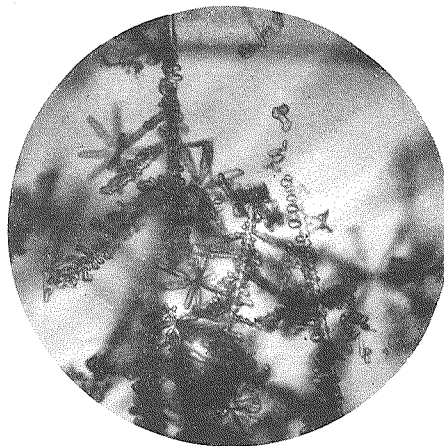

Temp. -12.2°C $\times 60$

26

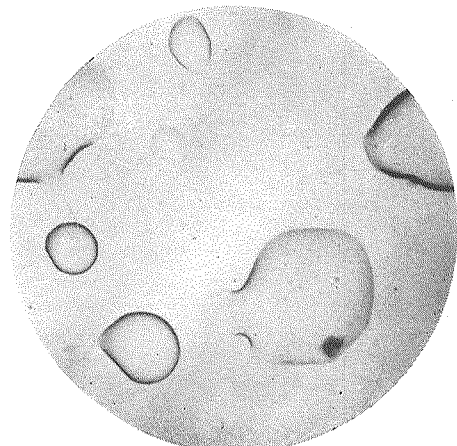

$\times 60$

27

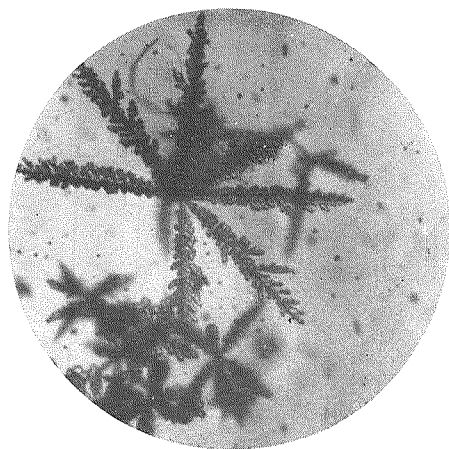

× 60

30



× 60

28

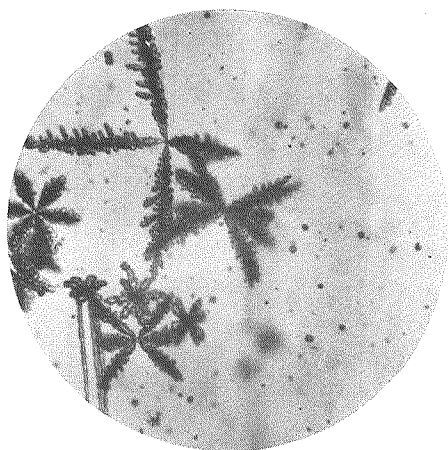

× 60

31

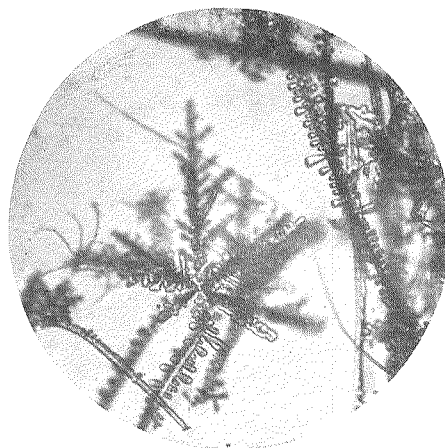

× 60

29

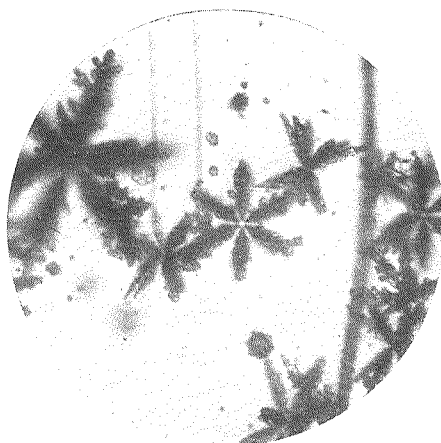

× 80

33

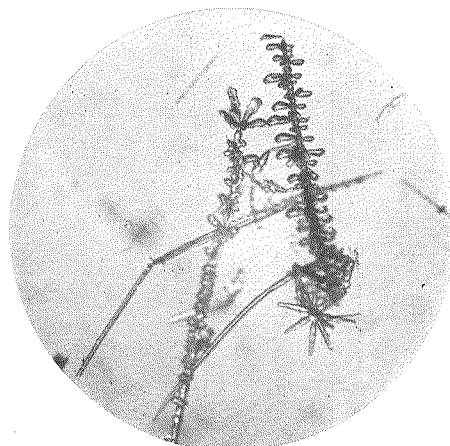

× 60

32

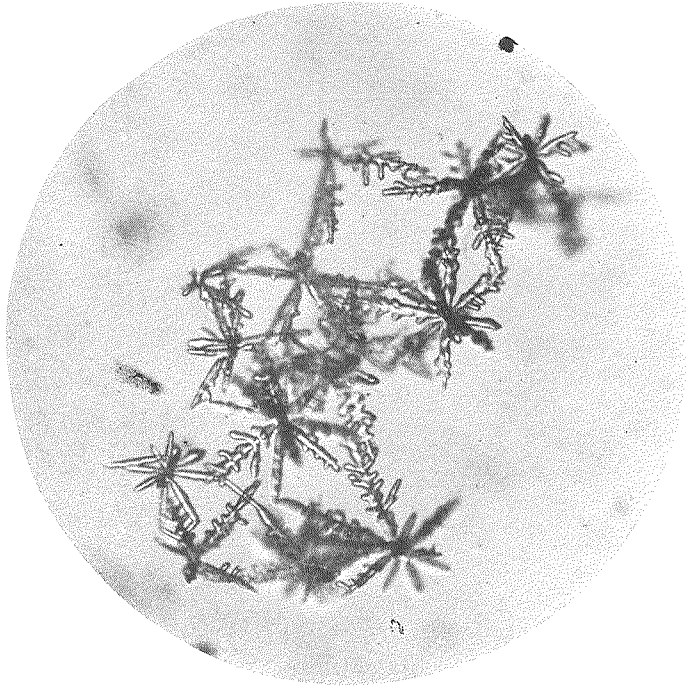

× 100

40

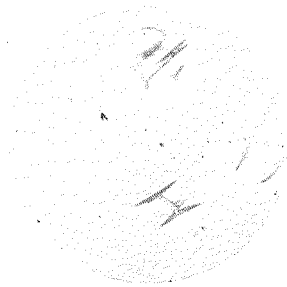

× 105

36

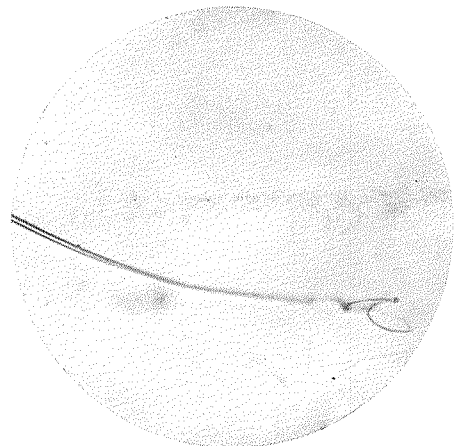
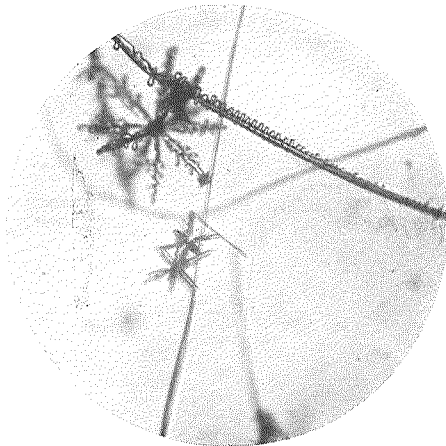

× 60

34

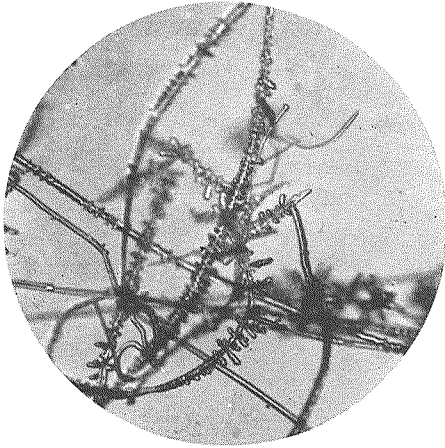

× 60

38

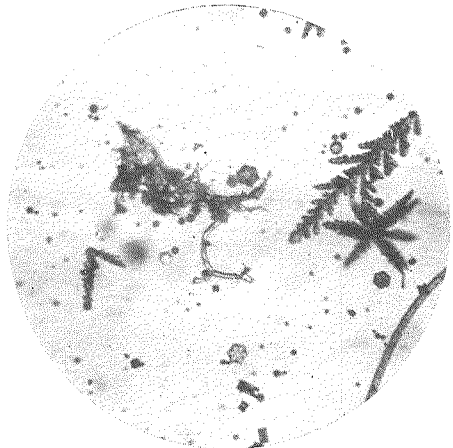

× 60

35

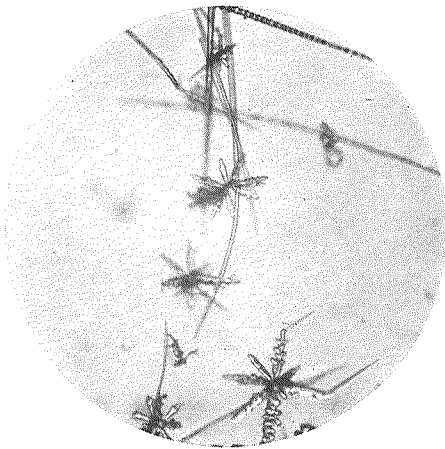

× 60

39



× 60

37

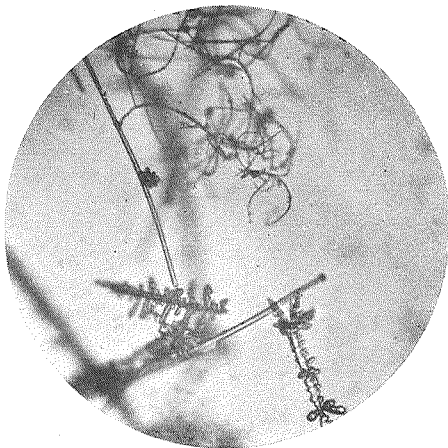

× 60

41

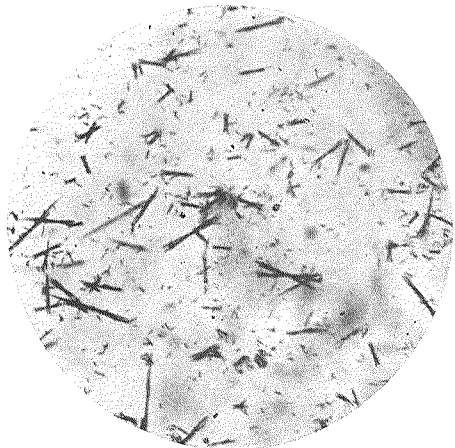

× 30

42

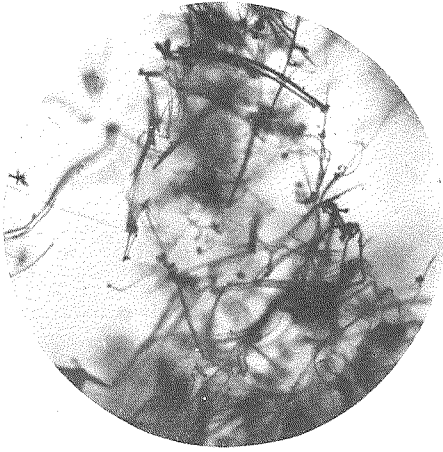

× 25

45

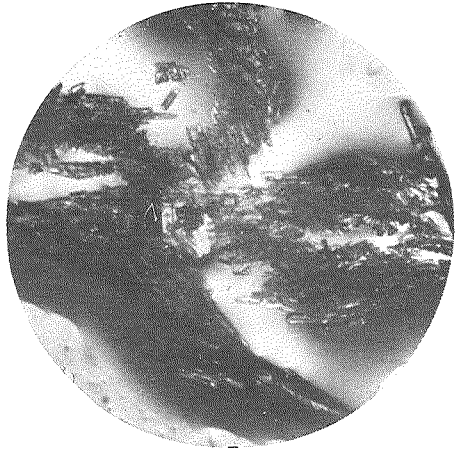

× 60

43



× 25

46

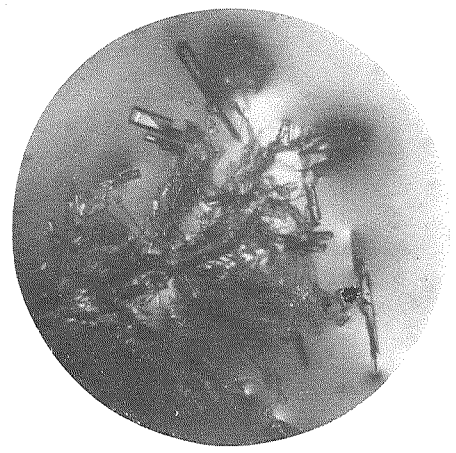

× 60

44



× 60

47

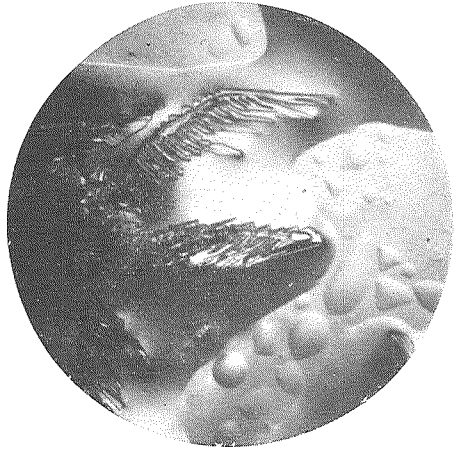

× 60

48

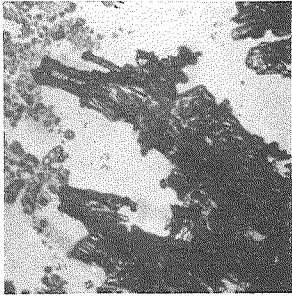

× 53

49

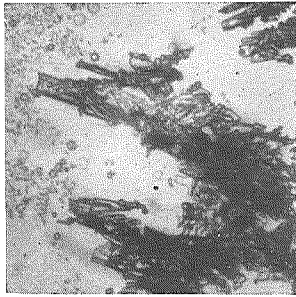

× 53

50

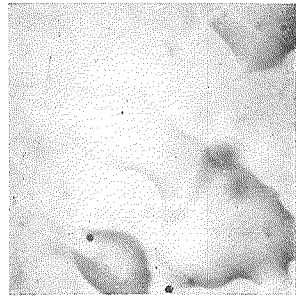

× 53

51

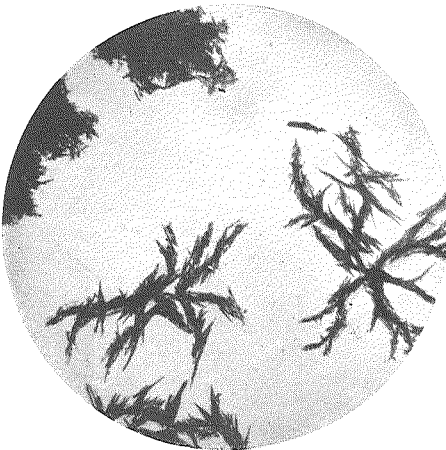

× 24

55



× 24

52



× 24

56

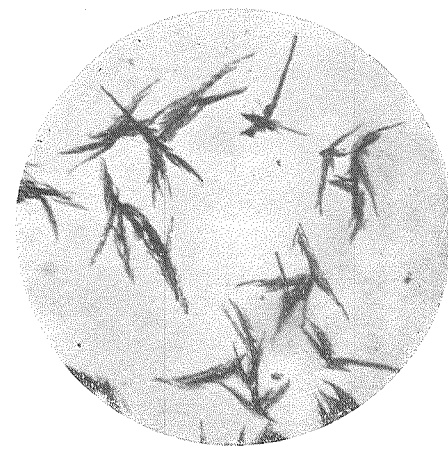

× 24

53



× 60

58



× 24

54



× 24

59

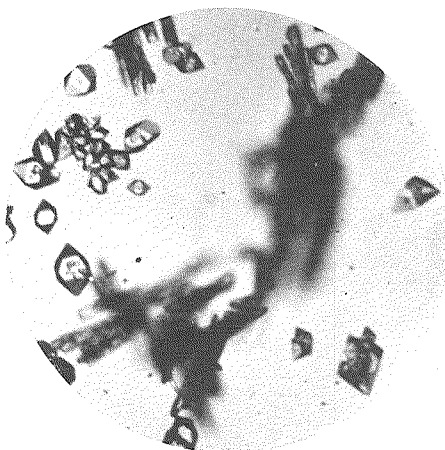

× 24

57



× 24

60

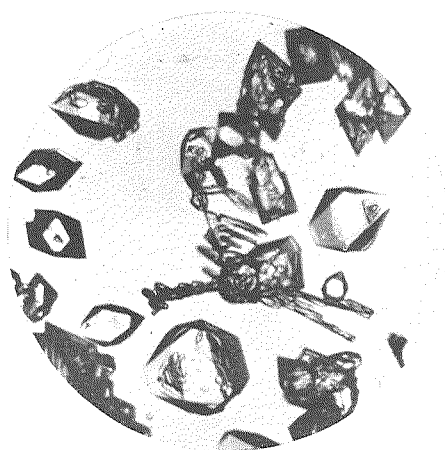

× 24