



HOKKAIDO UNIVERSITY

Title	Physical Studies on Deposited Snow. V. ; Dielectric Properties.
Author(s)	YOSIDA, Zyungo; OURA, Hirobumi; KUROIWA, Daisuke et al.
Citation	Contributions from the Institute of Low Temperature Science, 14, 1-33
Issue Date	1958
Doc URL	https://hdl.handle.net/2115/20223
Type	departmental bulletin paper
File Information	14_p1-33.pdf



Physical Studies on Deposited Snow. V.*

Dielectric Properties.

by

Zyungo YOSIDA, Hirobumi OURA, Daisuke KUROIWA,
Tosio HUZIOKA, Kenji KOJIMA and Seiiti KINOSITA

*Applied Physics Section, Institute of
Low Temperature Science*

(Manuscript Received April 1958)

III. The Dielectric Properties of Snow.

§1. Dielectric properties of ice.

Although dielectric properties are amongst the most important properties of insulating materials, so far as the authors are aware, little study has ever been devoted to the dielectric properties of snow. The authors have measured the dielectric constant and dielectric loss of a large number of snow samples and have tried to find out whether any relationship exists between those quantities and the structure of ice network composing the snow (1), (2). (Within a mass of snow small ice grains or short ice rods join with one another to form a three dimensional ice network. Its microphotographs are shown on pp. 8 and 9 of Part III of this series of papers.) Snow is an insulator made of air and ice, that is, it is a two-component system. (When wet, it becomes a three-component system composed of air, ice and water. In this study, except on rare occasions, wet snow will be left out of account.) The dielectric properties of snow should be altered according to the content of ice within it, that is, according to its density. But the sameness in the density of snow does not result in that of the dielectric properties unless the structure of ice network composing the snow is also the same. The electric force to which the ice within the snow mass is actually subjected is different from the external electric force applied to the snow. The latter force is modified within snow by the electric interactions which that force induces between one part of the ice network and another. The ice in the snow responds to this modified electric force; the dielectric properties of snow are nothing but the sum total of such responses occurring in every part of the ice network. It is quite to be expected that the induced electric interactions between the parts of the networks differ when their structure is different. In this way the snow of the same density generally shows different dielectric properties according to the structure of its ice networks.

So far as is indicated by the results of experiments on ice made by many

* Contribution No. 393 from the Institute of Low Temperature Science.

authors up to the present, the ice itself is not simple in respect to its dielectric properties. The results obtained by different authors do not agree well and sometimes large discordances are found between them. Such disagreements may have been caused by some failure existent in the measuring technique, but they seem to have arisen largely from the impurities contained in very small amount in the samples of ice subjected to the experiments. Indeed the minutest impurities bring about great changes in the dielectric properties of ice. SMYTH and HITCHCOCK (3) found that (for the frequency of applied alternating electric force lower than one kilocycle per second) the dielectric constant of ice made from many times distilled water was increased by more than 20% when potassium chloride was added to the water in so small an amount as 0.0002M to one litre of water. This is the same thing as to introduce one molecule of potassium chloride among 278,000 molecules of ice. Recently HUMBEL, JONA and SCHERRER (4) also made a detailed experimental study of the effect of impurities upon the dielectric properties of ice. They found that the dielectric constant of ice containing some impurities could reach the value 1000 at low frequencies of the applied alternating electric force while that of pure ice lay in the vicinity of a value 80. The ice networks of deposited snow always contain some impurities. Along with the complicated structure of the ice networks themselves, the impurities within them are likely to bring many complications to the dielectric properties of snow.

When an alternating electric force

$$E = E_0 \cos 2\pi ft \quad (1)$$

is applied to an insulator, it responds generally to the force in different manners according to whether the frequency f is high or low. The electric displacement D —a quantity used for representing the dielectric response of an insulator to the applied electric force—turns out to be expressed by

$$D = D' \cos 2\pi ft + D'' \sin 2\pi ft. \quad (2)$$

The ratios

$$\epsilon' = D'/E_0 \quad \text{and} \quad \epsilon'' = D''/E_0 \quad (3)$$

are called “dielectric constant” and “dielectric loss factor” respectively. Both ϵ' and ϵ'' depend on the frequency f . (The ratio of D to E , the dielectric constant in the ordinary sense, depends in this case on f as well as on t : $\epsilon = D/E = \epsilon'(f) + \epsilon''(f) \tan 2\pi ft$.) So long as ϵ'' is different from zero, the energy imparted to the insulator by the applied electric force is partly lost in the form of heat. That loss of energy, the dielectric loss, occurring per unit volume of the insulator during one cyclic period ($1/f$) of the electric force is equal to $\epsilon'' E_0^2 / 4\pi$. The angle δ defined by $\tan \delta = \epsilon'' / \epsilon'$ is called “loss angle.”

Fig. 1 graphs the results of experiments conducted by the present authors on samples of ice made by freezing distilled water or water produced by melting newly

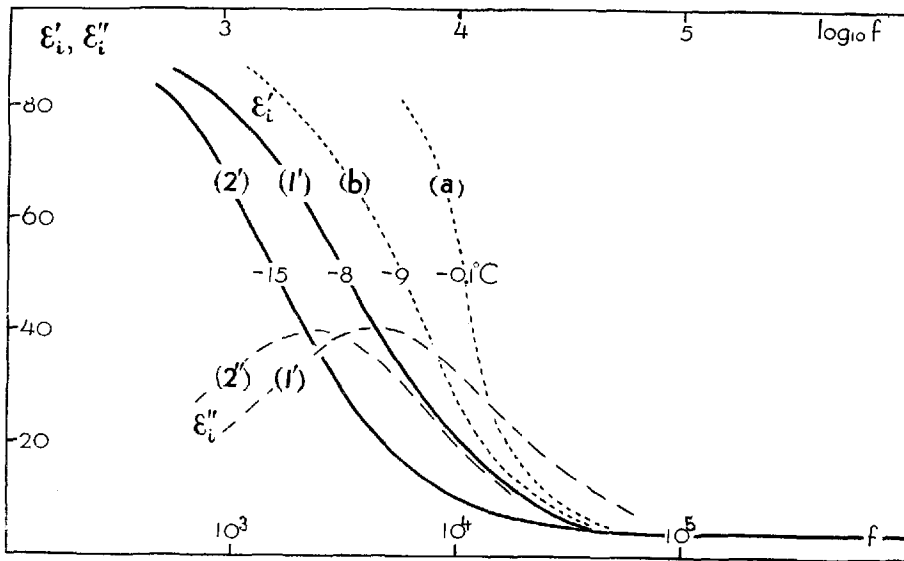

Fig. 1 Dielectric constant ϵ'_i and dielectric loss factor ϵ''_i of ice versus $\log f$. f : frequency (cycle/sec) of the applied alternating electric force.

Curves (1'), (2'), (1''), (2''): ice of distilled water.

Curves (a), (b): ice made by freezing melted snow.

fallen snow. (How the experiments were conducted will be described in §4 below.) The dielectric constant ϵ'_i and loss factor ϵ''_i of the ice of distilled water changed respectively against the frequency f of the applied alternating electric force as shown by curves (1'), (2') and (1''), (2'') for the temperatures indicated beside the respective curves. (It should be noted that the horizontal f -axis of Fig. 1 is graduated by logarithmic scale.) The frequency f was made to alter from a little below one kilocycle to about one megacycle. Nearly in accord with the results of the other authors, ϵ'_i has a value near 80 or 90 for low frequencies and the value 4.5 for frequencies higher than 100 KC (KC: kilocycle) regardless of the difference of temperature. Curves ϵ''_i - $\log f$ take the form of a mound in the range within which curves ϵ'_i - $\log f$ descend in the direction of increasing frequency. The mound slopes down gently on both sides tending to coincide with the base line at the ends: ϵ''_i seems to vanish at $f=0$ and at $f=\infty$.

The small circles in the left half (A) of Fig. 2 indicate the points which are determined on $\epsilon'-\epsilon''$ plane by the values of ϵ'_i and ϵ''_i belonging to the same frequencies f , in the case of the above noted ice of distilled water. The small circles lie along the periphery of a half circle of which the centre O is positioned slightly off below the ϵ' -axis. The value of f increases, as indicated by the numerical figures attached to the small circles, along the periphery of the half circle from its right end P, through its top, towards the left end Q. Points P and Q correspond

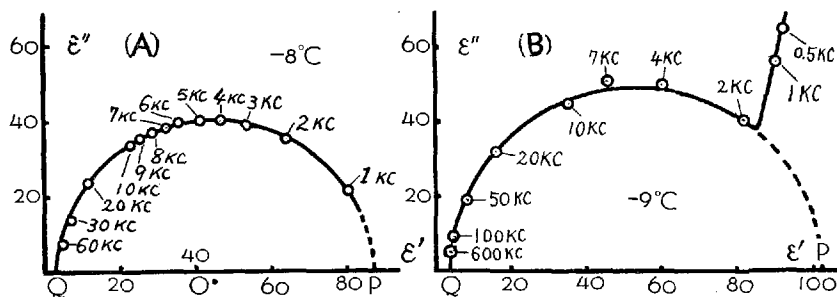

Fig. 2 ϵ' - ϵ'' curves of ice. Left: ice of distilled water. Point O is the centre of the half circle. Right: ice made by freezing melted snow.

to $f=0$ and $f=\infty$, giving the values of the *static dielectric constant* ϵ_s , the ϵ' corresponding to $f=0$, and the *optical dielectric constant* ϵ_o , the ϵ' corresponding to $f=\infty$, respectively. It is very difficult or entirely impossible to determine ϵ_s or ϵ_o directly by the experimental measurements, but one can determine their values by constructing such a half circle as above on the basis of ϵ' and ϵ'' observed for finite values of f . The half circle of Fig. 2 (A) gives $\epsilon_{s,o}=90.0$ and $\epsilon_{i,o}=4.5$.

§ 2. DEBYE'S formulae and the dielectric constant and loss factor of ice and snow.

Let such an insulator be supposed that its electric displacement D changes according to the formula

$$D = \left\{ \epsilon_s - (\epsilon_s - \epsilon_o) \exp(-t/\tau) \right\} E_o, \quad \epsilon_s > \epsilon_o, \quad (4)$$

when it is subjected to a constant electric force E_o which is applied to it at $t=0$ and the force is kept to act upon it thereafter (t : time). Then it is theoretically proved that that insulator shows, when acted upon by an alternating electric force of frequency f , the dielectric constant ϵ' and the dielectric loss factor ϵ'' given by

$$\epsilon' = \epsilon_o + \frac{\epsilon_s - \epsilon_o}{1 + (2\pi f\tau)^2}, \quad (5)$$

$$\epsilon'' = (\epsilon_s - \epsilon_o) \frac{2\pi f\tau}{1 + (2\pi f\tau)^2}. \quad (6)$$

Inversely, if ϵ' , ϵ'' of an insulator can be described by these formulae, that insulator will show the electric displacement D which changes according to formula (4) under the influence of the constant electric force E_o . Formulae (5) and (6) are called "DEBYE'S formulae". When one puts $f=0$, $f=\infty$ in formula (5), ϵ' turns out to be respectively equal to ϵ_s and ϵ_o . Therefore ϵ_s and ϵ_o are nothing but the static and optical dielectric constants respectively.

When plotted against $\log f$, ϵ'' of formula (6) gives a curve looking like a mound similar to the experimental ϵ'' -curves (1''), (2'') shown in Fig. 1 of the previ-

ous section. The mound is symmetric in form with respect to a vertical line passing through the point $\log f = \log (1/(2\pi\tau))$. ϵ' of formula (5) is represented by horizontal lines $\epsilon' = \epsilon_s$ and $\epsilon' = \epsilon_o$ respectively to the left and right of the region of $\log f$ within which ϵ'' rises to form the mound. Within that region which may be called "region of anomalous dispersion", ϵ' descends towards the lower right from ϵ_s to ϵ_o just as the experimental curves $\epsilon' - \log f$ (1'), (2') of Fig. 1 do. The experimental curves (1'), (1''), (2'), (2'') are redrawn as thick curves in Fig. 3 while the theoretical curves obtained from DEBYE's formulae (5), (6) are shown by thin curves in the same figure. On making those theoretical curves, ϵ_s and ϵ_o in formulare (5), (6) were respectively taken equal to 90 and 4.5 which values respectively were found in the previous section for the static and optical dielectric constants of the ice of distilled water. The value of τ was so chosen that the top of the mound of theoretical curves of ϵ'' might coincide with that of the experimental.

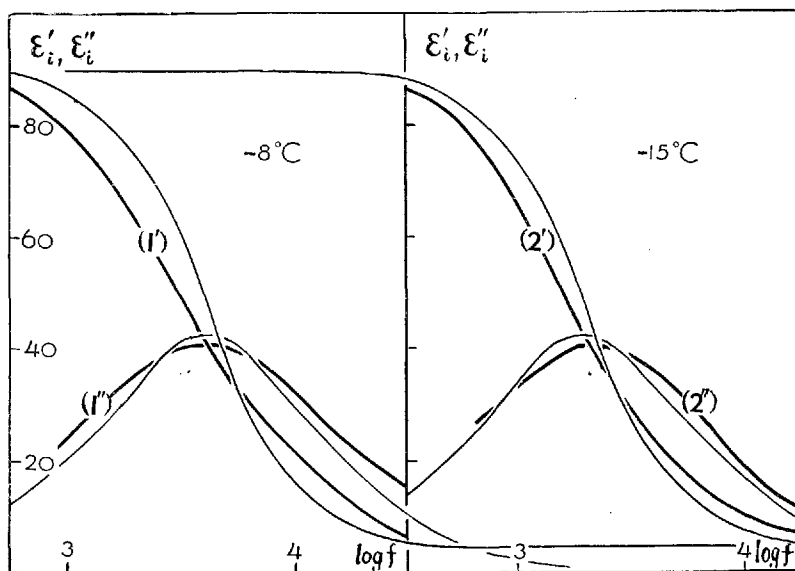

Fig. 3 Comparison of the theoretical and the experimental curves $\epsilon'_i - \log f$, $\epsilon''_i - \log f$ of ice. The thin lines represent theoretical values drawn after the DEBYE formulae. The thick ones, the experimental, are the same as shown in Fig. 1 by the same marks.

Fig. 3 shows only the region of anomalous dispersion where both ϵ' and ϵ'' make large changes. Even within such a region the agreement between the theoretical and experimental curves is rather good as seen from the figure. Outside that region the agreement is much better, both the curves, theoretical and experimental, uniting themselves into horizontal lines. In this way the dielectric constant ϵ'_i and the dielectric loss factor ϵ''_i of ice can well be represented by the DEBYE formulae when appropriate values are given to the three characteristic constants

ϵ_s , ϵ_0 , τ contained in those formulae. In actual fact the dielectric behaviour of any insulator under any electric force acting upon it can be calculated if ϵ' and ϵ'' of the insulator are known for all the values of frequency f . Therefore one can specify the dielectric properties of ice once he succeeds in determining on it the values of the three characteristic constants $\epsilon_{i,s}$, $\epsilon_{i,0}$ and τ_i . As will be seen later, snow also shows $\epsilon' - \log f$, $\epsilon'' - \log f$ curves which can approximately be represented by DEBYE'S formulae. Therefore the same point which was stated just above for ice is applicable also to snow.

The experimentally determined ϵ'_i , ϵ''_i of the ice of distilled water made a half circle in $\epsilon' - \epsilon''$ plane as illustrated in the left half of Fig. 2. Indeed the relation between ϵ' and ϵ'' which can be obtained by eliminating f from DEBYE'S formulae (5), (6) can also be represented by a half circle with its chord coincident with the ϵ' -axis. The left and right extremities of the chord correspond to ϵ_s and ϵ_0 respectively.

According to formula (4) at the beginning of this section, the electric displacement D of the insulator rises instantaneously to $\epsilon_0 E_0$ at the instant when the constant electric force E_0 is applied and then continues to increase to reach $\epsilon_s E_0$ after a time several times longer than τ . After that D keeps the latter value as long as the constant electric force E_0 is maintained to act upon the insulator. In other words, D lags in reaching the value $\epsilon_s E_0$ which it should take ultimately. Since that lag becomes larger as τ is longer, τ can be taken as a measure of that lag. τ is called "relaxation time". It is such a lag that causes ϵ' and ϵ'' of an insulator to alter with f in the way described in the preceding paragraphs. If the lag does not occur, that is, if $\tau=0$, ϵ' and ϵ'' turn out to be constant regardless of f , being respectively equal to ϵ_s and 0 as will be seen from DEBYE'S formulae (5), (6) by putting $\tau=0$ in them. Air is such an insulator. The dielectric constant ϵ' of air is a constant slightly larger than one for all the frequencies while its dielectric loss factor ϵ'' entirely vanishes.

The value of relaxation time τ can be determined from the mound-like $\epsilon'' - \log f$ curve. If the frequency corresponding to the top of the mound of that curve is denoted by f_m , τ is given by the reciprocal of $2\pi f_m$, that is, $\tau = 1/(2\pi f_m)$. Curves $\epsilon'' - \log f$ in Fig. 1 give for the ice of distilled water $\tau_i = 3.54 \times 10^{-5}$ sec at -8°C and $\tau_i = 6.12 \times 10^{-5}$ sec at -15°C .

As was mentioned at the beginning of the previous section, the results of experiments performed by individual authors on the dielectric properties of ice differ from one another. How great those disagreements are will be seen from the following table:

Characteristic constants of polycrystalline ice.

Author	$\epsilon_{i,s}$	$\epsilon_{i,0}$	τ_i (unit: 10^{-5} sec)
SMITH, HITCHCOCK (3)	74.6	3.0	$1.846 \exp(-0.1015 \theta)$

WINTSCH (5)	73.0	7.5	$2.246 \exp(-0.0906 \theta)$
ERRERA (6)	77.2	3.0	$2.9 \exp(-0.090 \theta)$
MURPHY (7)	95.0	3.5	$1.85 \exp(-0.106 \theta)$
Present authors	90.0	4.5	3.54 at -8°C
			6.12 at -15°C

θ : temperature expressed on the CELSIUS scale.

§ 3. The dielectric constant ϵ'_i and loss factor ϵ''_i of ice as effected by the impurities contained in it. Imaginary ice and snow.

As was noted in § 1, when ice contains impurities, its dielectric constant and loss factor turn out to be much different from those of pure ice at low frequencies of the applied alternating electric force. It is well known that the ice forming snow always contains impurities, but much work is necessary before their sorts and amounts can be classified. The present authors determined experimentally the Cl-content (content of chlorine ion) of the snow samples which they subjected to dielectric experiments; that content was used as an indicator of the amount of impurities contained in the samples. Other authors who have made detailed examinations on the impurities in snow state that they are mainly constituted of NaCl (8). Therefore Cl-content may be said to be at least one of the quantities which can reasonably be chosen as a measure of the total amount of impurities. Snow samples taken from the snow cover deposited on the ground near the author's Institute were found to contain generally 10—30 mg of chlorine ions per kilogram of snow.

When ϵ'_i observed on the ice made from the melt of newly fallen snow is plotted against $\log f$, it gives curves (a), (b) shown in Fig. 1 of § 1. They differ largely from curves (1'), (2') of the pure ice within the range of f lower than 100 KC; the difference must have arisen from the presence of impurities in the ice of melted snow. When the observed values of ϵ'_i , ϵ''_i of the ice are plotted on $\epsilon' - \epsilon''$ plane, the observed points (light small circles) are found to be arranged as shown in the right half (B) of Fig. 2. The observed points belonging to frequencies higher than 2 KC lie along a circular arc while those belonging to lower frequencies construct a straight segment rising steeply towards the upper right. Inorganic salts such as NaCl contained in ice should impart to it the electric conductivity σ called "ion-conductivity". Then it can be proved by the theories of electricity that the ice should have additional loss factor $\epsilon''' = 2\sigma/f$ besides the proper dielectric loss factor ϵ'' . ϵ''' increases rapidly with the decrease in f , being effective only at low frequencies. It must be the ion-conductivity imparted to the ice which gave rise to that segment shooting up from the end of the circular arc in Fig. 2 (B), because it indicates also rapid rise of loss factor within the region of low frequency.

Let it be supposed that the impurities take effect only in causing some change in the proper dielectric properties of the ice but do not impart to it any ion-conductivity. Then ϵ'_i and ϵ''_i of the ice would have completed a half circle which

is obtained by supplementing the circular arc of $\epsilon'_i - \epsilon''_i$ by another arc of the same curvature such as the one shown by broken line in Fig. 2 (B). The imaginary ice which is supposed in such a manner as above could be treated like a pure ice with different characteristic constants $\epsilon_{i,s}$, $\epsilon_{i,o}$ and τ_i . Two of them, $\epsilon_{i,s}$, $\epsilon_{i,o}$, are given by the end points P and Q of the supplemented half circle. The third characteristic constant, τ_i , has the same value both for the actual and imaginary ices, because the frequency f_m of which the reciprocal divided by 2π is equal to τ_i lies within the range of high frequency where the ion-conductivity has little effect. Obviously the dielectric properties of the actual and imaginary ices agree with each other except within the range of low frequency where the ion-conductivity exerts influence.

The ion-conductivity of ice is of a very complicated nature and accurate knowledge about it is still wanting. On the other hand, the ice networks composing snow always contain impurities making themselves ion-conductive, which will bring matters concerning snow into a hopeless complexity. Therefore the present authors will, in making studies on the dielectric properties of snow in the following sections, avoid this complexity by postulating an imaginary snow. One gets it, just as in the above case of imaginary ice, by supposing in his mind that the actual snow has lost its ion-conductivity. The dielectric properties of the imaginary snow should then be specified by the three characteristic constants ϵ_s , ϵ_o , and τ .

§ 4. The experimental determination of the dielectric properties of snow and ice.

An electric condenser which holds insulating material between its two electrodes can be replaced, from the electrical point of view, by a combination of an electric capacity C and an electric resistance R . C and R can be considered to be combined either in parallel connection or series one, and it is only a matter of convenience which of the two connections should be chosen. (Of course, the values of C and R differ according to the choice). Here the parallel one will be taken up. Then the quantities characterising the dielectric properties of the insulating material are found to stand in the following relationships with C and R . If the capacity which the condenser shows in the case of absence of the insulating material is denoted by C_0 , the dielectric constant ϵ' of the material is given by

$$\epsilon' = C/C_0. \quad (7)$$

The loss factor ϵ'' of the insulating material is connected with R and C_0 by the relation

$$\epsilon'' = 1/(2\pi fRC_0), \quad (8)$$

where f is the frequency of the applied electric force. (When the condenser is considered to be replaced by R and C in series connection, the relations between these quantities and ϵ' , ϵ'' are given in forms different from formulae (7) and (8).) There-

fore the values ϵ' and ϵ'' of snow or ice can be obtained by constructing a condenser filled with snow or ice and by determining experimentally the values of C and R of that condenser. If such a determination is made for different frequencies f and from that curves of $\epsilon' - \epsilon''$, $\epsilon'' - \log f$ are drawn, the three characteristic constants ϵ_s , ϵ_o , τ of snow or ice will be obtained from those curves. Since one can find explanations on the experimental way of determining R and C combined in parallel connection in any ordinary text-book of practical electricity, a description will be given here only of the construction of the condenser used for the present experiments.

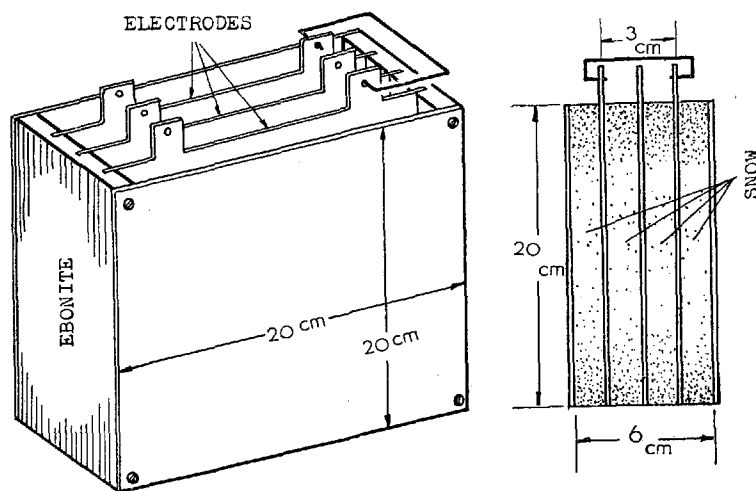

Fig. 4 Condenser used for determining ϵ' and ϵ'' of snow.

Fig. 4 shows the condenser used for experimenting on snow. It is a case made of two brass plates ($20\text{ cm} \times 20\text{ cm}$) and two thick ebonite plates ($6\text{ cm} \times 20\text{ cm}$, 1 cm thick). Snow was put into the case carefully so as to fill the case completely without undergoing any compression. Then three nickered brass plates ($20\text{ cm} \times 20\text{ cm}$, 1 mm thick) were inserted into the snow in such a way that they are kept parallel to one another with clearances of 1.4 cm between any two of them. Accurate parallelism was secured by the aid of grooves cut on the ebonite plates. The middle of the three nickered plates and the two side ones joined electrically by a wire form a condenser, the former and the latter plates serving as the respective electrodes. When the condenser was constructed with no snow between the plates the value C_0 of its capacity was found to be equal to 59 cm.

In the case of experiments on ice, use was made of a small condenser composed of three brass plates ($10\text{ cm} \times 10\text{ cm}$) which were separated 3 mm from one another. This condenser was immersed in water contained in a vessel and the whole was placed in the cold room to be frozen. As in the above case of snow, the

middle plate and the side two joined by a wire were used as the electrodes of the condenser.

The frequency f of the alternating electric potential applied to the condensers was changed within the range from $\frac{1}{2}$ KC to 1000 KC (=1 MC). In addition to that a frequency of 3483 KC was used in order to examine whether or not any change might occur to the dielectric properties beyond the higher limit of the above noted range of frequencies. The oscillator used for producing the alternating current and the method adopted for the measurement of C and R were:

range of frequency	oscillator	method of measurement
0.5 KC—20 KC	CR oscillator	bridge method
30 KC—1000 KC	HARTLEY oscillator	substitution method
3483 KC	quartz oscillator	substitution method.

§ 5. Examples of curves $\epsilon' - \log f$, $\epsilon'' - \log f$, $\epsilon' - \epsilon''$ observed on snow samples.

The following five figures (Figs. 5—9) show curves $\epsilon' - \log f$, $\epsilon'' - \log f$, $\epsilon' - \epsilon''$ obtained on snow samples of different sorts. In each of the figures, curve $\epsilon' - \log f$ and curve $\epsilon'' - \log f$ are shown respectively by thick and broken curves in part (A) while curve $\epsilon' - \epsilon''$ is indicated in part (B) by thick curve. When the results of more than one experiment are contained in one figure, let each of the experiments be distinguished by numbers (1), (2), ..., and let the curves $\epsilon' - \log f$, $\epsilon'' - \log f$, $\epsilon' - \epsilon''$ belonging to the same experiment be denoted respectively by adding one, two and three primes to the number of the experiment, for example, by (2'), (2''), (2''') in the case of experiment (2). Sometimes in the description of the figures below, for the sake of brevity, the curves belonging to the same experiment will be represented as a whole by the single number of the experiment itself, such as three curves (2'), (2''), (2''') as a whole by "curves (2)".

Description of Figs. 5—9.

Fig. 5. Newly fallen snow composed of dendritic crystals. Cl-content: 15 mg/kg. Temperature: -1°C . It had in its natural state the density 0.095 gr/cm^3 and showed curves (1). When the same snow was made to become denser by being artificially compressed, the curves changed into curves (2) and (3). The densities corresponding to the cases (2) and (3) are 0.132 and 0.254 gr/cm^3 respectively.

Fig. 6. Somewhat wet snow made by the accumulation of snow flakes desposited at air temperature -1.8°C . Cl-content: 25 mg/kg. The snow was too soft to be put into the condenser in its natural state; it was pushed into the condenser in a compressed state. In that condition it showed density 0.38 gr/cm^3 and gave curves (1). When the water contained within the snow was frozen by lowering the temperature to -7°C , ϵ' , ϵ'' were reduced to almost half their prior values as shown by curves (2'), (2'').

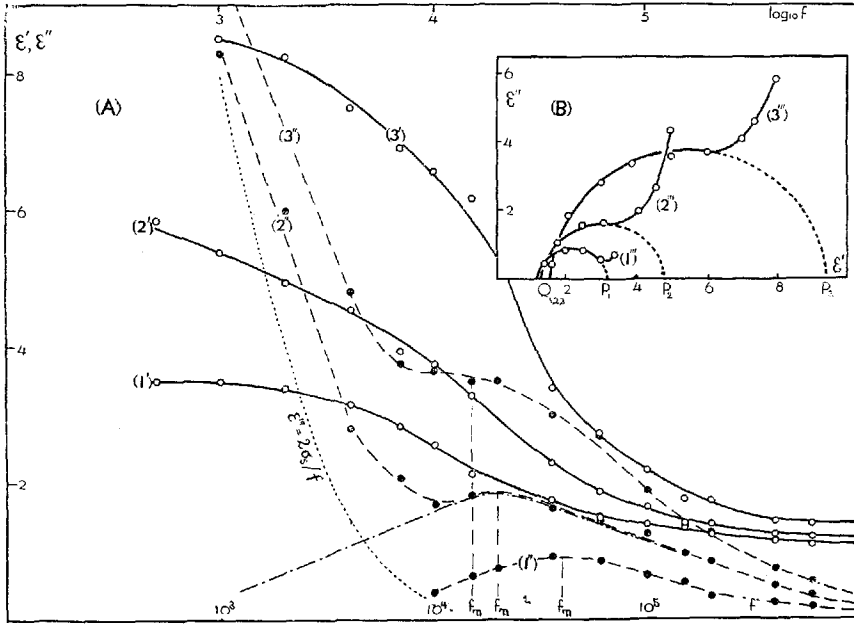

Fig. 5 Newly fallen snow. (Descriptions of Figs. 5—9 are given in the text.)

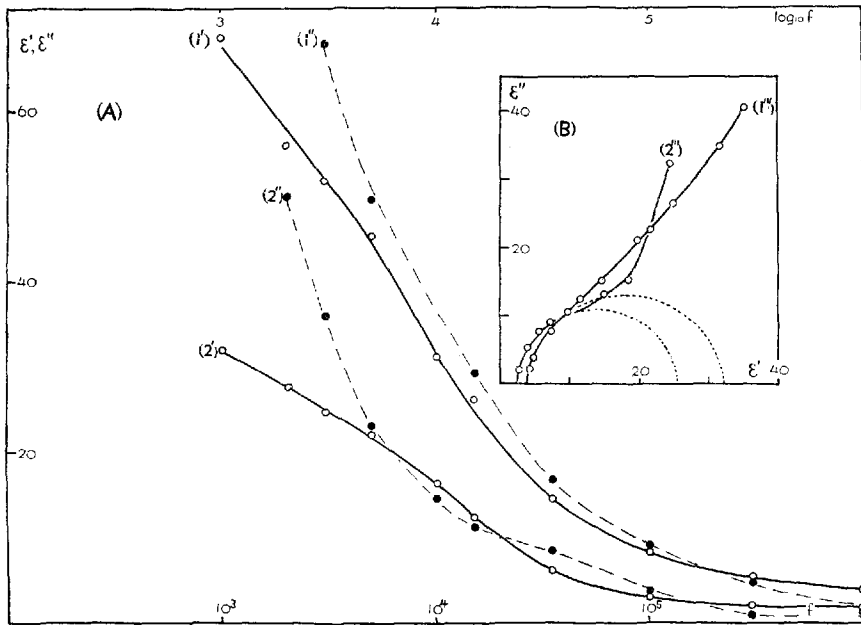

Fig. 6 Wet snow.

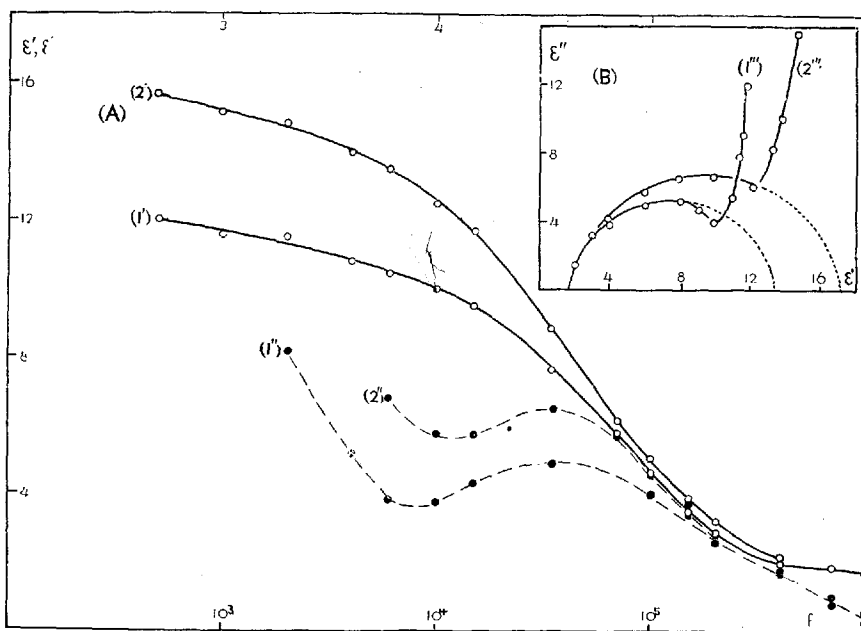

Fig. 7 Compact snow.

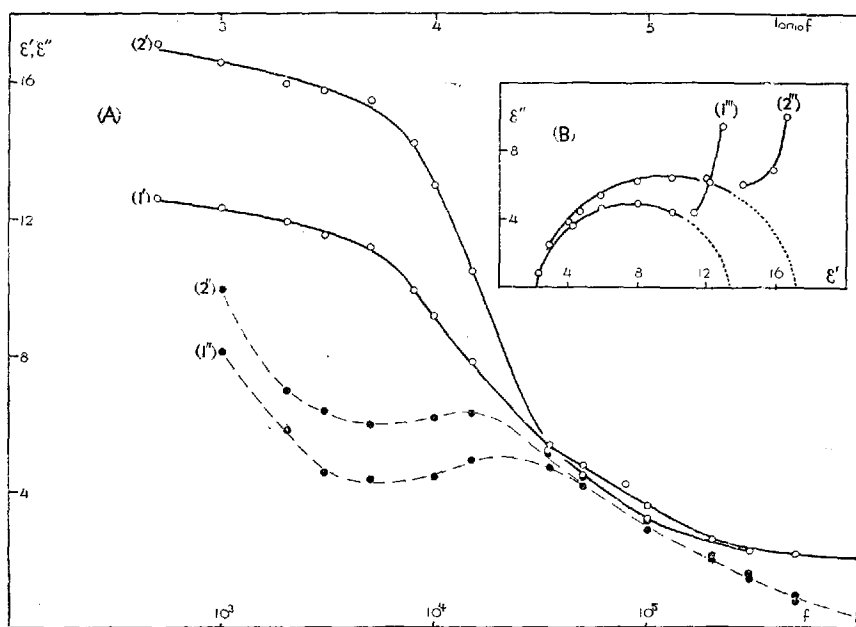

Fig. 8 Granular snow.

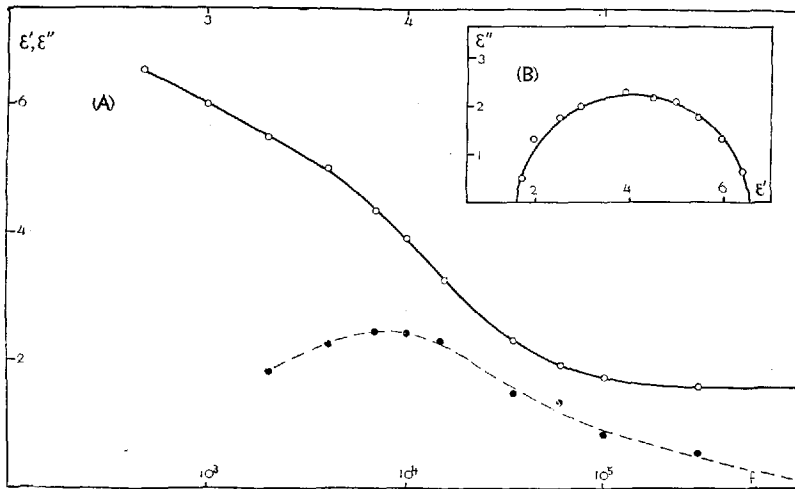

Fig. 9 Pure snow made of artificially produced hoar crystals.

Fig. 7. Compact snow. Cl-content: 35 mg/kg. Density: 0.4 gr/cm³. Temperature: -3.0°C. Curves (1) were obtained immediately after the snow had been put into the condenser. When the condenser was kept as it stood at -3.0°C for 24 hours, ϵ' and ϵ'' were increased as shown by curves (2). Such an increase in ϵ' and ϵ'' must have been caused by some change which had occurred during that interval to the structure of ice networks composing the compact snow.

Fig. 8. Granular snow. Cl-content: 12.5 mg/kg. Density: 0.41 gr/cm³. Temperature: -4°C. Diameter of granules composing the snow was 2-4 mm. As in the previous case of Fig. 7 curves (1) had changed into curves (2) while the condenser was left for 24 hours as it contained the snow after the snow had been put into the condenser.

Fig. 9. Snow with no impurities. Density: 0.29 gr/cm³. Temperature: -8.5°C. This was a snow made of artificially produced hoar crystals. A wooden box on the bottom of which was placed a water bath heated electrically was put in the cold room. A part of the lid of the box was replaced by a metal plate. The vapour evaporating from the bath condensed on the bottom surface of the metal lid producing a large amount of hoar crystals. They were found to be chemically pure, and, when gathered together, gave a snow with no impurities.

Curve $\epsilon''-\log f$ takes the form of a mound and curve $\epsilon'-\epsilon''$ shows no tendency to deviate from a half circle as in the case of pure ice shown in Fig. 1 and Fig. 2 (A).

In all the above figures except Fig. 6, curves $\epsilon'-\log f$, when viewed from right to left, runs at first horizontally straight, begins to rise and then curves downwards tending to become horizontal again. Curve $\epsilon''-\log f$ rises at first gently and soon

reaches the top of a mound-like rise. After passing over the mound it begins to rise again steeply towards the upper left. This steep rise must be caused by the additional loss factor $\epsilon''' = 2\sigma_s/f$ due to the ion-conductivity σ_s of the *snow* caused in it by the impurities. (σ_s is the conductivity of *snow* which is considered as a continuous medium. σ_s should be distinguished from the conductivity σ_i of the *ice* composing the snow.) Therefore, if there had been no ion-conductivity, curve $\epsilon'' - \log f$, in the above described figures, would have taken the form of a mound in such a way as indicated by the dot-and-dash curve shown in Fig. 5. In the exceptional case of Fig. 6 the impurities were so effective as to make the rise in the left portion of curve $\epsilon'' - \log f$ so steep that it concealed entirely the top of the mound. As for curve $\epsilon' - \epsilon''$, it makes an arc of a circle on more than its left half with a curved segment rising towards the upper right joined to the right end of the arc. It must also be the impurities that caused such a segment to deviate from the circular path.

What was stated in the above paragraph implies that ϵ' and ϵ'' of snow would come to be described by the DEBYE's formulae (5), (6) if the ion-conductivity were imagined to have been removed from the snow. The snow imagined in such a way is the "imaginary snow" noted at the end of §3. The relaxation time τ of the imaginary snow is determined by the frequency f_m corresponding to the top of the mound-like rise in the actual curve of $\epsilon'' - \log f$; τ is given by $\tau = 1/(2\pi f_m)$. If the circular portion on the left half of the actual curve of $\epsilon' - \epsilon''$ is supplemented by an arc to form a half circle in such a way as indicated by the broken curve in part (B) of Figs. 5-8, the right and left extremities of the chord of that half circle give respectively ϵ_s and ϵ_o of the imaginary snow.

It is naturally expected that snow will show a tendency to have a larger ϵ' and ϵ'' , the larger its density ρ is, because the ice of which ϵ' and ϵ'' are larger than those of air increases in amount as the snow becomes denser. Such a tendency is most clearly seen in the case of Fig. 5, where ϵ' and ϵ'' of snow increased under an artificial compression applied to it. But the increase in ϵ' and ϵ'' is not always accompanied by an increase in density. In the cases of Figs. 7 and 8, snow increased its ϵ' and ϵ'' by being merely left to stand for 24 hours with no sign of increase in its density. As mentioned above, this was due to the change which occurred to the structure of the ice networks of the snow. The cases of Figs. 7 and 8 are examples of what was noted at the end of the first paragraph of §1.

The influence on ϵ' of a change occurring to the ice networks of snow displays itself much more conspicuously at low frequencies of the applied alternating electric force than at high ones, that is, the influence is much stronger on ϵ_s than on ϵ_o . That is because, as seen from the table at the end of §2, ϵ_s of ice is seventy to ninety times as large as that of air while ϵ_o of ice barely reaches several times that of air. (For air both ϵ_s and ϵ_o are equal to one.) In actual fact curves (1') and (2') in Figs. 7 and 8 tend to coincide with each other towards the right while they are

widely separated from each other in the left portion of the figures where frequency is low.

But when the change in structure of ice networks is caused by freezing of water contained in wet snow, the influence of the change in ϵ' will cease to be small at high frequencies. That is because ϵ' of water differs very much from that of ice at high frequencies while ϵ' has almost the same value for both water and ice within the range of low frequency. Even at such high frequencies as 1000 KC or thereabouts, ϵ' of water still retains the value 80 which it has at low frequencies. On the other hand, ϵ' of ice is, as shown above, reduced to below 5 when the frequency is raised beyond 50 KC. Such a large change in dielectric constant accompanying the freezing of water turns out to act as an efficient agent for altering ϵ' of snow at the high frequencies. As shown in Fig. 6, ϵ_s and ϵ_o were reduced by freezing the wet snow to 80% and 45% of their initial values. In this case the influence of freezing was rather larger at high frequencies than at low ones.

In the case of the pure snow of Fig. 9, curve $\epsilon'' - \log f$ takes the form of a single mound giving relaxation time $\tau = 1.85 \times 10^{-5}$ sec at -8.5°C . As shown in the table at the end of §2, the present authors obtained for pure ice $\tau_i = 3.54 \times 10^{-5}$ sec at -8°C which is about twice the above value for the pure snow. Such a difference between the relaxation times of pure snow and pure ice must have originated from the fact that the snow is a two-component system composed of air and ice. On this point discussion will be offered below in §8.

§6. The dielectric constant ϵ' , the dielectric loss factor ϵ'' of the imaginary snow in relation to its density ρ .

(1) *The static and optical dielectric constant ϵ_s , ϵ_o of the imaginary snow in relation to its density ρ .* The dielectric constant ϵ' observed on the pure ice at two different temperatures -8°C , -15°C tended, as illustrated by curves (1'), (2') of Fig. 1, to the common value 90 as the frequency f of the applied alternating electric force was decreased. Such was the case also for the increasing frequency; two curves (1'), (2') in that figure united into a single horizontal line $\epsilon' = 4.5$ in the region of high frequency. Those facts indicate that the change in temperature has little effect on either the static or the optical dielectric constants $\epsilon_{i,s}$ and $\epsilon_{i,o}$ of pure ice. Therefore also ϵ_s and ϵ_o of the imaginary snow should not be influenced by the temperature.

Fig. 10 shows ϵ_s and ϵ_o of the imaginary snow in relation to its density ρ . The upper part (A) shows ϵ_s and the lower (B) ϵ_o . Different marks indicate the different sorts of snow: cross in circle—soft snow, light circle—compact snow, solid circle—granular snow. The density of soft snow is generally smaller than 0.2 gr/cm^3 ; the marks of soft snow, corresponding in both the parts (A), (B) to densities larger than 0.2 gr/cm^3 , show soft snows which were artificially compacted. The crosses

in the lower part (B) are CUMMING's values of ϵ_0 which he determined by making an electromagnetic wave of wave length 3.2 cm reflect upon the surface of snow covers having different densities (9).

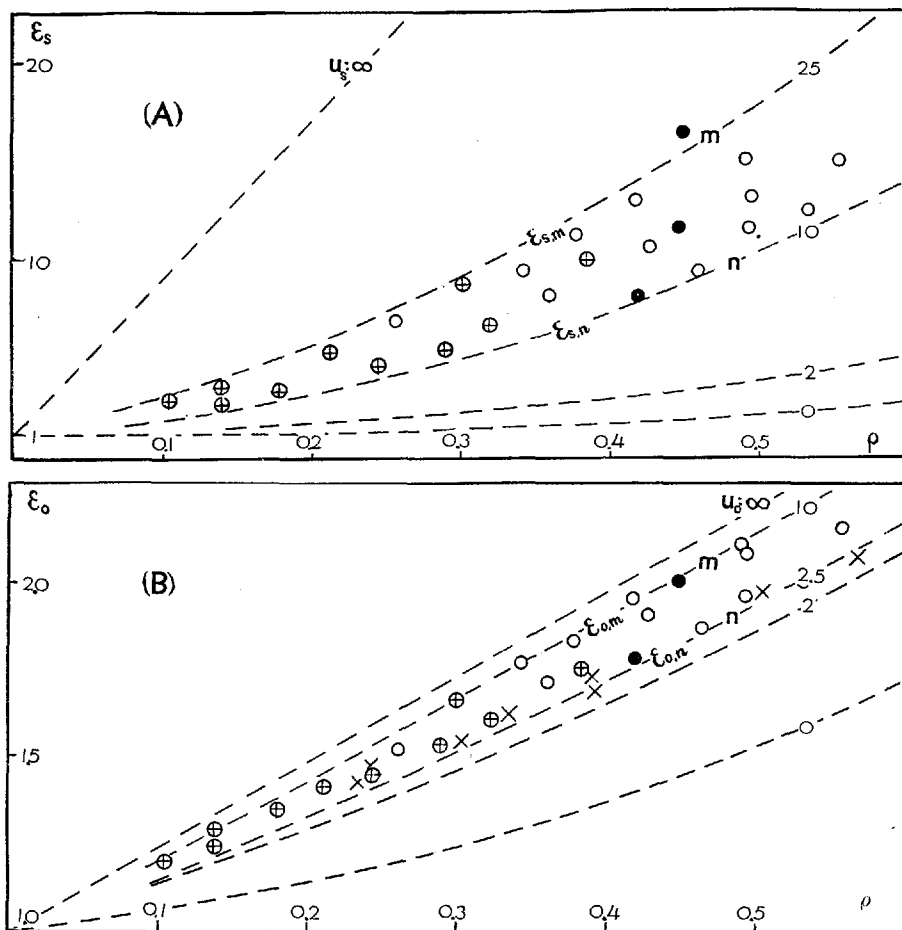

Fig. 10 Static dielectric constant ϵ_s and optical dielectric constant ϵ_0 of snow versus its density ρ . The broken curves represent WIENER's formula. Numerical figures attached to the curves indicate the value of *Formzahl* u . The observed points are distinguished according to the sort of snow: cross in circle—soft snow; light circle—compact snow; solid circle—granular snow. Mark of soft snow corresponding to $\rho > 0.2$ shows an artificially compacted soft snow. Crosses in the lower figure are after CUMMING.

(2) WIENER's formulae. "Formzahl". Snow is a two-component system composed of ice and air; the ice forms complicated three-dimensional networks and the air fills up the spaces between them. Any properties of a two-component system should be fixed by those of the components themselves and the manner of their

arrangements within the system. But to deduce theoretically from the latter things the properties of the system is generally difficult and most problems of such a sort have not yet been solved. However, Otto WIENER (10) succeeded in finding a formula which is useful for connecting the dielectric constant of a two-component system with that of its components. Let the components of the system be called (*a*) and (*i*) and their complex dielectric constant be denoted by ϵ_a and ϵ_i respectively. (It is often convenient to consider ϵ' , ϵ'' together in combination. Then they are combined to the form $\epsilon = \epsilon' + j\epsilon''$ called "complex dielectric constant". Here j is the imaginary unit $\sqrt{-1}$.) WIENER introduced a number u which he named *Formzahl* and showed that the complex dielectric constant ϵ of the two-component system is related with ϵ_a and ϵ_i according to the formula

$$\frac{\epsilon - 1}{\epsilon + u} = p \frac{\epsilon_a - 1}{\epsilon_a + u} + q \frac{\epsilon_i - 1}{\epsilon_i + u}, \quad (9)$$

where p and q are respectively the ratios of the volumes occupied by components (*a*), (*i*) to the volume occupied by the system. Hence $p + q = 1$. In the case of snow, one of the components (*a*) is air and the first term on the right side of equation (9) vanishes, for the complex dielectric constant ϵ_a of air is always equal to 1. (For air $\epsilon' = 1$, $\epsilon'' = 0$.) Then the complex dielectric constant $\epsilon = \epsilon' + j\epsilon''$ of snow turns out, after transforming equation (9), to be given by

$$\epsilon = \frac{u(p + \epsilon_i q) + \epsilon_i}{(p\epsilon_i + q) + u}. \quad (10)$$

Here ϵ_i denotes the complex dielectric constant $\epsilon'_i + j\epsilon''_i$ of ice while q is given by the density ρ of snow divided by the density ρ_i of ice. (The present authors had already taken advantage of WIENER's theory in dealing with the heat conductivity of snow in § 8 of Part I of this series of papers. If E , D , ϵ —electric force, electric displacement, dielectric constant—are substituted for G , H , m —temperature gradient, heat flux, ratio of heat conductivity to the standard heat conductivity—which were used there, the same reasoning established there can also be applied to the present case of the dielectric phenomena. Then the above equation (10) can be obtained by putting $m = \epsilon$, $m_a = 1$, $m_i = \epsilon_i$ in equation (7) on p. 66 of Part I.)

(3) *The maximum and minimum of ϵ_s , ϵ_o at any density ρ .* Since ϵ'' vanishes for $f = 0$ and $f = \infty$, the complex dielectric constant ϵ corresponding to these extreme frequencies coincides respectively with the static and optical dielectric constants ϵ_s and ϵ_o . Therefore the above equation (10) should hold also between the static and optical dielectric constants of snow and ice, that is, between ϵ_s and $\epsilon_{i,s}$ and between ϵ_o and $\epsilon_{i,o}$. The broken curves in Fig. 10 show the relations between ϵ_s , ϵ_o and ρ which are obtained from formula (10) by substituting for ϵ_i the values 80 or 3.5 and for u the numerical figures attached to the curves. Numbers 80 and 3.5 are the values of static and optical dielectric constants $\epsilon_{i,s}$, $\epsilon_{i,o}$ of ice. (As was shown in the table at the end of § 2, the values of those constants determined by

different workers do not agree. The present authors, judging from the values shown there, believe the above-noted values 80 and 3.5 to be most probable for those constants.) The observed points, including those obtained by CUMMING (crosses in part (B) of Fig. 10), lie within the bands bounded on the two sides by the broken lines marked **m** and **n**. The values of u belonging to those border lines **m**, **n** are respectively 25 and 10 in the case of static dielectric constant ε_s and 10 and 2.5 in the case of optical dielectric constant ε_o . That is to say, if values of u concerning the static and optical dielectric constants are respectively denoted by u_s and u_o ,

$$25 > u_s > 10, \quad 10 > u_o > 2.5.$$

It was noted in §1 that ε_s and ε_o of snow samples having the same density do not always have the same values. Instead they are here found to lie each between rather distinct two limits:

ε_s lies between

$$\varepsilon_{s,m} = \frac{105 + 2155 \rho}{105 - 86 \rho} \quad \text{and} \quad \varepsilon_{s,n} = \frac{90 + 862 \rho}{90 - 86 \rho}, \quad (11)$$

ε_o lies between

$$\varepsilon_{o,m} = \frac{13.5 + 27.3 \rho}{13.5 - 2.73 \rho} \quad \text{and} \quad \varepsilon_{o,n} = \frac{6 + 6.82 \rho}{6 - 2.73 \rho}. \quad (12)$$

These formulae for the limits are obtained from formula (10) by replacing p and q by $\{1 - (\rho/\rho_i)\}$ and (ρ/ρ_i) respectively and using above noted values for ε_i and u . The curves **m**, **n** in Fig. 10 represent formulae (11), (12).

As noted above, the present authors applied WIENER'S theory to the problem of heat conductivity of snow in Part I of this series of papers and determined u_h , the *Formzahl* concerning the heat conductivity. (cf. p. 66 of Part I. There u_h was written merely as u .) In that case the quantities corresponding to ε_i , ε_a of formula (9) were respectively $m_i = 94.2$ and $m_a = 2$. In the present case $\varepsilon_i = 80$, $\varepsilon_a = 1$ for the static dielectric constant and $\varepsilon_i = 3.5$, $\varepsilon_a = 1$ for the optical dielectric constant. Then u_h is expected to be nearer to u_s than to u_o . In actual fact it was found, near to the above inequality $25 > u_s > 10$, that

$$20 > u_h > 7,$$

as shown in the table on p. 66 of Part I.

(4) *The formulae giving the range of ε' , ε'' for any density ρ .* It is naturally expected that the larger u_s is, the larger u_o will be. Therefore such imaginary snows that have the maximum value 25 of u_s will have the maximum value 10 of u_o , that is, such imaginary snows that have $\varepsilon_{s,m}$ will have $\varepsilon_{o,m}$ at the same time. Then, since the dielectric constant and loss factor ε' , ε'' of the imaginary snow should be represented by DEBYE'S formulae (5), (6), ε' and ε'' must respectively be smaller than

$$\epsilon'_m = \epsilon_{0,m} + \frac{\epsilon_{s,m} - \epsilon_{0,m}}{1 + (2\pi f\tau)^2}, \quad \epsilon''_m = (\epsilon_{s,m} - \epsilon_{0,m}) \frac{2\pi f\tau}{1 + (2\pi f\tau)^2} \quad (13)$$

for any value of density ρ . In a similar way it is shown that ϵ' , ϵ'' are respectively larger than

$$\epsilon'_n = \epsilon_{0,n} + \frac{\epsilon_{s,n} - \epsilon_{0,n}}{1 + (2\pi f\tau)^2}, \quad \epsilon''_n = (\epsilon_{s,n} - \epsilon_{0,n}) \frac{2\pi f\tau}{1 + (2\pi f\tau)^2} \quad (14)$$

In this way the dielectric constant and loss factor ϵ' , ϵ'' of the imaginary snow are determined against its density ρ by the following mathematical inequalities:

$$\epsilon'_m > \epsilon' > \epsilon'_n, \quad \epsilon''_m > \epsilon'' > \epsilon''_n. \quad (15)$$

(5) *The relaxation time τ of the imaginary snow.* Unlike $\epsilon_{i,s}$, $\epsilon_{i,o}$ the relaxation time τ_i of ice changes as the temperature is changed. It increases with decreasing temperature. The formulae shown in the table at the end of §2 which were given by different authors, indicate that the dependence of τ_i on temperature $\theta^\circ\text{C}$ may be represented approximately by

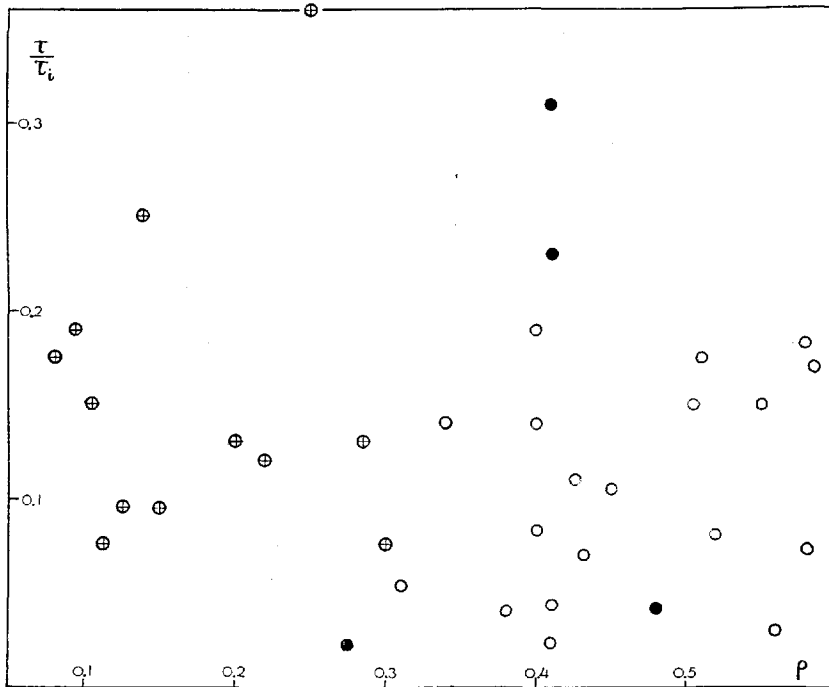

Fig. 11 The ratio of τ to τ_i versus the density ρ of snow. τ and τ_i are respectively the relaxation times of snow and ice at the same temperature. Cross in circle: soft snow; light circle: compact snow; solid circle: granular snow.

$$\tau_i = 2 \times 10^{-5} \exp(-0.1 \theta) \text{ sec.} \quad (16)$$

According to this equation τ_i is at -10°C and -20°C respectively 2.7 times and 7.4 times as long as at 0°C . Therefore the relaxation time τ of the imaginary snow must also change largely with the change in temperature.

As will be explained later in §8, the fact that the ice within snow forms networks with numerous interstices between them has the effect of reducing the relaxation time of the ice itself which is comprised of the networks. In addition to that, such a structure of ice within snow in combination with the ion-conductivity due to the impurities, develops a mechanism to produce a new relaxation time differing from that proper to the ice. Of course both the reduction and the production of relaxation time vary according to the configuration of the networks. Due to such circumstances the relaxation time τ of snow turns out to be less than three-tenths of the relaxation time τ_i of ice at the same temperature. No definite relationships seem to exist between τ and temperature θ or density ρ of snow except that τ increases with the decreasing temperature on one and the same sample of snow. In Fig. 11 is plotted against ρ the ratio τ/τ_i , where τ_i is the relaxation time of ice computed for temperature θ by formula (16).

§7. WIENER's *Formzahl* and the structure of ice networks in snow.

It is a difficult problem to put the *Formzahl* u of snow in any exact relationship with the structure of its ice networks. But what will be discussed below may throw some light on that problem.

Let a mass of snow contained in a cube of unit volume be considered. If the whole ice composing the snow be supposed to be divided into a number of pillars standing parallel to the applied electric force E like (A) of Fig. 12, the *Formzahl* u for such a structure turns out to be ∞ . Structure (A) is equivalent electrically

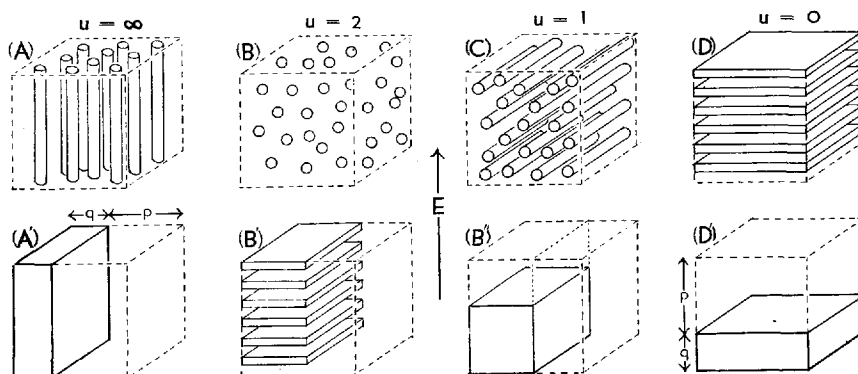

Fig. 12 Hypothetical simplest structures of the ice composing snow on which the *Formzahl* u can be obtained by theoretical calculation. The figures in the bottom row represent the electrical equivalences to those in the top row.

to structure (A) in which the ice pillars of (A) are collected into a single rectangular block of solid ice. It can easily be seen from (A) that the complex dielectric constant of the snow should be equal to $p+q\varepsilon_i$ in this case, where ε_i denotes the complex dielectric constant of ice. Indeed, when one puts $u=\infty$ in formula (10) of the previous section, it gives $\varepsilon=p+q\varepsilon_i$.

In structure (B) of Fig. 12 the ice is imagined to have been separated into many small spheres distributed randomly within the cube of a unit volume. WAGNER proved that $u=2$ in this case (11). The same ε as that shown by structure (B) can also be possessed by structure (B') in which the ice takes the form of an assembly of many thin plates lying within a part of the cube. Structure (B') is then equivalent to structure (B''), where the ice plates are united into a single ice block located near one of the edges of the cube. When the ice takes the form of an assembly of circular rods lying perpendicularly to the electric force E as illustrated in (C) of Fig. 12, u was shown by LORD RAYLEIGH to be equal to one (12). Structure (B'') can be used also in this case to represent an electrical equivalence of structure (C), provided that some alteration is made in the dimensions of the ice block.

Finally (D) represents the case in which the ice is divided into a number of thin plates lying perpendicularly to the electric force E . Obviously (D) is electrically equivalent to (D') in which all the plates are piled together on the bottom of the cube to form a block of ice. By the theories of electricity (D') is proved to have the dielectric constant $\varepsilon=\varepsilon_i/(p\varepsilon_i+q)$. The same ε is given if *Formzahl* u is put equal to zero in formula (10). Therefore in the case of (D) $u=0$.

The ice of (B) shows no continuations in any direction being dispersed within the cube of unit volume in the form of independent small spheres. There u has the value 2. In the case of (A) all of the ice makes longitudinal continuations in the direction of E , u becoming infinitely large at the same time. Therefore it may be concluded that the longitudinal continuations of ice give rise to the enlargement of *Formzahl* u . On the other hand, u is reduced from 2 to 1 when the ice comes to make transverse continuations by changing from spheres into horizontal rods in the case of (C). If the transverse continuations are further advanced by the stratification of ice as in the case of (D), u is finally reduced to zero. Then it may be said that the reduction in the value of u is caused by the development of transverse continuations of ice.

The ice networks composing snow have longitudinal as well as transverse continuations. The former cause increase in the value of u to more than 2 while the latter tend to reduce the value below 2. But the former power of raising u must be much stronger than that of reducing u of the transverse continuations, because the enlargement of u caused by the shift from structure (B) to (A) is infinitely large whereas the reduction of u accompanying the change from (B) to (D) is no more than 2. In this way it will well be expected that the *Formzahl* u of snow will in effect be always larger than 2, which is actually shown by Fig. 10 of

the previous section §6.

In order to ascertain the relationship supposed in the above paragraph to exist between u and the structure of ice networks, the present authors made the following experiments. They broke a block of compact snow into fragments and packed them together again to become snow samples of such large densities as 0.4 or 0.45 gr/cm³. The values of their u_s —*Formzahl u* for static dielectric constant—were determined several times after the samples had been put into the experimental condenser. At first the ice granules composing the snow should merely touch one another without being united by ice bonds with the result that the continuations of ice within the snow were weak. But, as time went on, the ice granules would gradually become united with one another to form strong networks, at the same time the continuations of ice being increased. Therefore u_s of such a snow sample should be enlarged while it was left to stand. The experiments were performed at two temperatures, -3°C and -20°C ; the results are shown respectively in parts (A), (B) of Fig. 13. As was expected, in both the cases u_s increased with time.

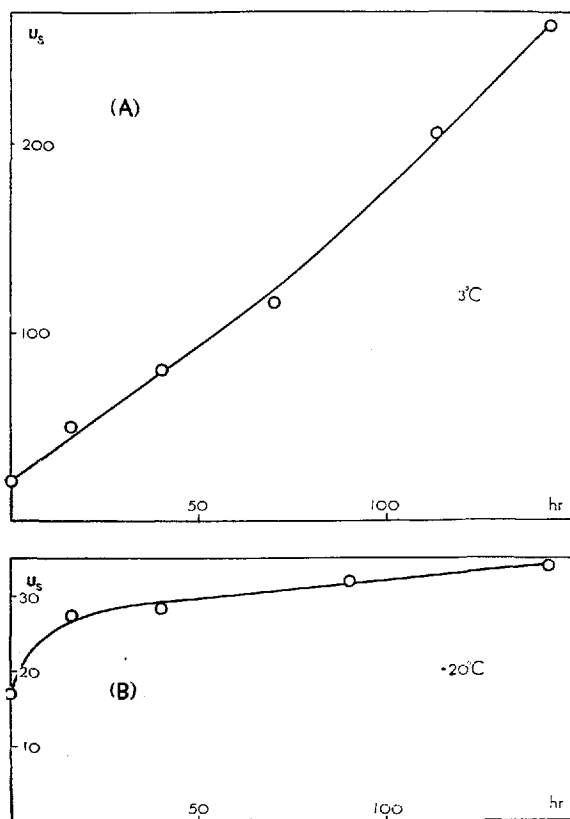

Fig. 13 The *Formzahl u_s* for the static dielectric constant of snow increases with time due to the sublimation metamorphosis.

The rate of increase of u_s turned out to be much larger at -3°C than at -20°C . This is in agreement with the fact that the higher the temperature is, so much the faster the ice continuations are developed. In both the above cases u_s increased to such an extent as to much exceed 25, which value was determined before as the maximum which snow can have (cf. Fig. 10). But such a restriction on the value of u_s should be applied only to snows in their natural states. The snow samples used for the present experiments were not natural snows as described above. (If the snow was immersed in oil its dielectric constant, consequently its *Formzahl* also, absolutely stopped to change. The oil filling the spaces within the snow completely arrested the phenomenon of sublimation due to which the change in the structure of snow normally occurs. cf. p. 40 of Part I of this series of papers.)

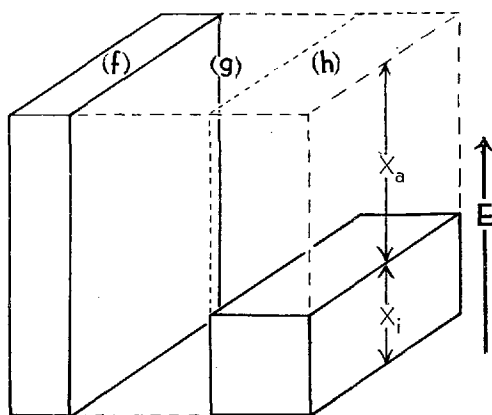

Fig. 14 Model representing the electrical equivalence of snow for any value of the *Formzahl* u . Parts (f) and (g) in combination represent the longitudinal continuation of ice within the snow while part (h) represents the transverse one.

What was stated above in this section suggests that snow of various sorts can be represented by such a model as shown in Fig. 14, so far as only their dielectric properties are concerned. That model is a combination of structures (A') and (D') of Fig. 12. In Fig. 14 the cube of unit volume is divided into three rectangular parts (f), (g) and (h). Part (f) is filled with ice from top to bottom while part (g) is empty. Parts (f) and (g) in combination are equivalent to structure (A) of Fig. 12 representing the longitudinal continuations of ice. Part (h) divides itself into two, the one empty and the other filled with ice. This part (h) is of the same structure as (D'), that is, it is equivalent to (D), and represents the transverse continuations of ice.

§ 8. Shortening of the relaxation time of snow.

Part (f) of Fig. 14 shows the same relaxation time τ_i as ice does, because it

is a block of ice quite continuous in the direction of the electric force E . But part (h) of that figure, being not continuous in that direction, has a relaxation time τ_h which is shorter than τ_i as will be shown below. Let the dielectric loss factor of parts (f) and (h) be denoted by ϵ_i'' and ϵ_h'' respectively. Then the dielectric loss factor ϵ'' of the whole cube of Fig. 14, that is, the loss factor of snow, is given by

$$\epsilon'' = a\epsilon_i'' + b \cdot 0 + c\epsilon_h'', \quad (17)$$

where a , b and c are constants which indicate the contributions from parts (f), (g) and (h) respectively. (The dielectric loss factor of part (g) is zero, because it is empty.) Dielectric loss factors ϵ_i'' , ϵ_h'' will each give, plotted against $\log f$, mound-like curves of which the tops are located at points $\log(1/2\pi\tau_i)$ and $\log(1/2\pi\tau_h)$ respectively. Those mounds will be gentle in their slopes as shown by the examples in Fig. 1. Therefore, provided that their tops are not separated from each other too much, curve $\epsilon'' - \log f$ of snow will also take the form of a mound with its top somewhere between the above noted tops. Then the frequency f_m corresponding to the top of curve $\epsilon'' - \log f$ gives the relaxation time τ of snow according to the formula $\tau = 1/2\pi f_m$. That relaxation time τ must be shorter than τ_i because it lies between τ_i and τ_h which is by itself shorter than τ_i .

(1) *Reduction of the relaxation time of ice contained in part (h) of Fig. 14.*

As shown in Fig. 3 of §2, ϵ_i' and ϵ_i'' of ice can rather well be represented by DEBYE's formulae (5), (6). Therefore, when ice is acted upon by a constant electric force E_0 , the electric displacement D will change according to formula (4) of §2, which means that the dielectric constant $\epsilon_i = D/E_0$ of ice increases from $\epsilon_{i,0}$ to $\epsilon_{i,s}$ as time goes on in the manner given by

$$\epsilon_i = \epsilon_{i,s} - (\epsilon_{i,s} - \epsilon_{i,0}) \exp(-t/\tau_i). \quad (18)$$

Then, when an electric force $E(t)$ varying with time in any way acts upon ice, it will show the following electric displacement $D(t)$:

$$D(t) = \epsilon_{i,0}E(t) + \int_0^t \left\{ (\epsilon_{i,s} - \epsilon_{i,0}) \tau_i \right\} E(u) \exp \left\{ -(t-u)/\tau_i \right\} du. \quad (19)$$

(If $D(t)$ calculated from this formula by putting $E(t) = \cos 2\pi ft$ in it is divided by $E(t)$, it gives the DEBYE formulae (5), (6).)

Let the heights of the ice block and the vacant space above it of part (h) of Fig. 14 be denoted by x_i and x_a respectively. Since the height of the cube of that figure is equal to 1, $x_i + x_a = 1$. When a constant electric force E_0 is applied to the system (h) ("part (h)" will be called "system (h)" hereafter) composed of the ice block and the vacant space, there hold the equations

$$x_a E_a(t) + x_i E_i(t) = E_0, \quad (20)$$

$$E_a(t) = \epsilon_i(t) E_i(t) = D_h(t), \quad (21)$$

where $E_i(t)$, $E_a(t)$ denote respectively the electric forces within the ice block and

the vacant space while $D_h(t)$ denotes the electric displacement within the system. Those equations yield

$$E_i(t) = \frac{E_0}{x_a \varepsilon_i(t) + x_i}, \quad (22)$$

which will give $D_h(t)$ by being substituted for $E(t)$ in equation (19). Then, noting that $\varepsilon_i(t) = D_h(t)/E_i(t)$, one gets from equations (19) and (22) the integral equation by which the dielectric constant $\varepsilon_i(t)$ of the ice block to be determined:

$$\frac{\varepsilon_i(t) - \varepsilon_{i,0}}{x_a \varepsilon_i(t) + x_i} = \frac{\varepsilon_{i,s} - \varepsilon_{i,0}}{\tau_i} \int_0^t \frac{du}{x_a \varepsilon_i(u) + x_i} \exp\left\{-\frac{(t-u)}{\tau_i}\right\}. \quad (23)$$

Differentiation with respect to t , transformation and then integration applied to this equation will yield

$$\frac{\varepsilon_{i,s} - \varepsilon_i(t)}{x_a \varepsilon_i(t) + x_i} = \frac{\varepsilon_{i,s} - \varepsilon_{i,0}}{x_a \varepsilon_{i,0} + x_i} \exp(-t/\tau_h), \quad (24)$$

$$\tau_h = \frac{x_a \varepsilon_{i,0} + x_i}{x_a \varepsilon_{i,s} + x_i} \tau_i. \quad (25)$$

Equation (24) shows, in a near sense, that the ice block of the system (**h**) should show the relaxation time τ_h given by equation (25). Since $\varepsilon_{i,0} < \varepsilon_{i,s}$, τ_h must be shorter than τ_i , that is, the relaxation time of ice is reduced in this case.

If the ice block reached the top of the cube of Fig. 14 without leaving any vacant space in part (**h**), the ultimate electric displacement which $D_h(t)$ should reach would have been the constant $\varepsilon_{i,s}E_0$, because $E_i(t)$ remains unchanged from the beginning to the end being equal to E_0 in such a case. Then τ_h would have coincided with τ_i . But, when there is such a vacant space, $E_i(t) = E_0/(x_a \varepsilon_i(t) + x_i)$ decreases as time goes on, because $D_h(t)$, consequently $\varepsilon_i(t)$, increase with time t . Then $\varepsilon_{i,s}E_i(t)$, the destination at which $D_h(t)$ is striving to arrive, is coming towards the advancing $D_h(t)$ with the result that the time of attaining that destination is shortened. As was noted in the last part of §2, the relaxation time is nothing but a measure of such a time of reaching the ultimate value. This is the physical reason why τ_h is shorter than τ_i as indicated by the above formula (25).

The dielectric constant $\varepsilon_h(t)$ of system (**h**) is related with $\varepsilon_i(t)$ as follows:

$$\varepsilon_h(t) = \frac{D_h(t)}{E_0} = \frac{\varepsilon_i(t)}{x_a \varepsilon_i(t) + x_i}. \quad (26)$$

Then equations (24), (25), (26) yield

$$\varepsilon_h(t) = \varepsilon_{h,s} - (\varepsilon_{h,s} - \varepsilon_{h,0}) \exp(-t/\tau_h) \quad (27)$$

with

$$\varepsilon_{h,s} = \frac{\varepsilon_{i,s}}{x_a \varepsilon_{i,s} + x_i}, \quad \varepsilon_{h,0} = \frac{\varepsilon_{i,0}}{x_a \varepsilon_{i,0} + x_i}.$$

Equation (27) is of the same form as equation (18). Therefore system (h) behaves like an ice which has the reduced relaxation time τ_h .

x_a and x_i should differ from one snow to another. Provisionally let them be considered equal to each other, that is, let $x_a = x_i = \frac{1}{2}$. As noted before, $\epsilon_{i,s} = 80$ and $\epsilon_{i,o} = 3.5$. Then equation (25) gives $\tau_h = 0.055 \tau_i$. Since τ , the relaxation time of snow, must lie between τ_i and τ_h , τ will be a few tenths of τ_i . This is in accord with the results shown in Fig. 11.

(2) *Relaxation time due to the electric conductivity of ice.* If the block of ice in part (h) of Fig. 14 has an electric conductivity σ_i , the electric force $E_i(t)$ prevailing within the block alters with time in a much more complicated manner than in the case described in the previous article (1). This must cause the relaxation time of the system (h) to differ from the value given by equation (25). In order to make matters simple, let it be supposed that the dielectric constant ϵ_i of ice is an actual constant which does not change in any way. This is the same as to suppose that the ice has no relaxation time and its electric displacement follows the changing electric force with no delay. Although in this way the dielectric delay is considered to have been completely dismissed from the ice, as indicated by MAXWELL long ago, the electric conductivity σ_i provides system (h) with a mechanism to produce a relaxation time given by

$$\tau_e = \frac{x_a \epsilon_i + x_i}{4\pi \sigma_i x_a} \quad (28)$$

The present authors estimate the value of σ_i at 10^5 e.s.u. from the results of their experiments on dielectric loss factor ϵ'' of snow at low frequencies. The value of σ_i was quite large because the snow contained impurities as noted above. As for ϵ_i , there is no definite reason to fix it at any value. Let it be assumed to be ten only for the reason that it should neither exceed 80 nor be smaller than 3.5. Then, if one puts $x_a = x_i = \frac{1}{2}$ as in the previous case of τ_h , equation (28) yields

$$\tau_e = 0.88 \times 10^{-5} \text{ sec,}$$

which is again a few tenths of τ_i .

In this way the fact that the relaxation time is shorter in snow than in ice can be explained by using the model shown in Fig. 14, in which either of or both the phenomena described in articles (1) and (2) are occurring.

§ 9. Some consideration on the dielectric constant and loss factor of snow.

(1) *Snow soaked with oil.* WIENER's "Proportionalitätspostulat". If the complex dielectric constant were raised by the same ratio α on both the components of a two-component system with no alteration in their geometrical configurations, the complex dielectric constant of the system would also be enlarged by that ratio α . This can be stated in another way as below. Let the complex dielectric con-

stants of the system and of the components, which shall be named (a) and (i), be denoted by ϵ , ϵ_a and ϵ_i respectively. Then, if another two-component system such that the geometrical configurations of its components are the same as those of the above and their complex dielectric constants are equal to $a\epsilon_a$, $a\epsilon_i$ is supposed, that system should have the complex dielectric constant equal to $a\epsilon$. This is the *Proportionalitätspostulat* offered by O. WIENER. But, so far as the present authors are aware, no experimental proof has ever been made for this postulate. Accordingly an attempt was made to examine it by using snow as the experimental material. In the case of snow one of the components is air. Its dielectric constant is real and equal to 1 regardless of the frequency f of the applied alternating electric force, that is, $\epsilon_a=1$. The other component is ice having the complex dielectric constant $\epsilon_i=\epsilon'_i+j\epsilon''_i$ which alters with f through a very wide range.

The present authors measured at -8.5°C ϵ' and ϵ'' of pure snow made by collecting artificially produced hoar crystals. Then they soaked it with mineral oil so that the air within the snow was completely replaced by the oil. Measurement was made on this snow again at the same temperature. The oil had a real dielectric constant equal to 2.5. Therefore in the case of the soaked snow $\epsilon_a=2.5$ and $\epsilon_i=\epsilon'_i+j\epsilon''_i$. Then, if the ice within the soaked snow had a complex dielectric constant 2.5 times as large as that of the ice within the unsoaked, the former snow would show the complex dielectric constant which is also 2.5 times as large as that of the latter. The fact that the complex dielectric constant $\epsilon_i(f)=\epsilon'_i(f)+j\epsilon''_i(f)$ of ice changes largely with f permits such a condition as above to be realised for a special pair of frequencies f_1, f_2 . Those frequencies should satisfy the equation

$$\epsilon'_i(f_2)+j\epsilon''_i(f_2)=2.5\left\{\epsilon'_i(f_1)+j\epsilon''_i(f_1)\right\}, \quad (29)$$

then the complex dielectric constant at f_2 of the soaked snow would be equal to 2.5 times that of the unsoaked at f_1 .

Let the dielectric constant ϵ'_i and loss factor ϵ''_i of the ice composing the snow be supposed to be represented by DEBYE'S formulae (5), (6) with $\epsilon_{i,\infty}=80$ and $\epsilon_{i,0}=3.5$. Then the frequencies f_1, f_2 satisfying equation (29) can be found in the following way. The circular arc marked G in Fig. 15 represents a part of the half circle showing the relation between ϵ'_i and ϵ''_i . The curve marked H is the half circle which relates $\epsilon'_i/2.5$ with $\epsilon''_i/2.5$. Then ϵ'_i and ϵ''_i belonging to the cross point R_1 of the two half circles G, H are respectively equal to $\epsilon'_i(f_1)$ and $\epsilon''_i(f_1)$. Point R_2 on arc G which lies on the elongation of segment OR_1 2.5 times more distant from point O than R_1 gives $\epsilon'_i(f_2)$ and $\epsilon''_i(f_2)$. Curves $\epsilon'_i-\log f$, $\epsilon''_i-\log f$ are shown in the left half of Fig. 15; they are marked I and J respectively. On constructing those curves the relaxation time τ_i was put equal to 4.68×10^{-5} sec, the value determined by formula (16) of § 6 for the temperature -8.5°C . The value of $\epsilon'_i(f_1)$, $\epsilon'_i(f_2)$, $\epsilon''_i(f_1)$, $\epsilon''_i(f_2)$ are shown on these curves by the rectangular and triangular marks. Then the points on the axis of $\log f$ lying right under those marks give

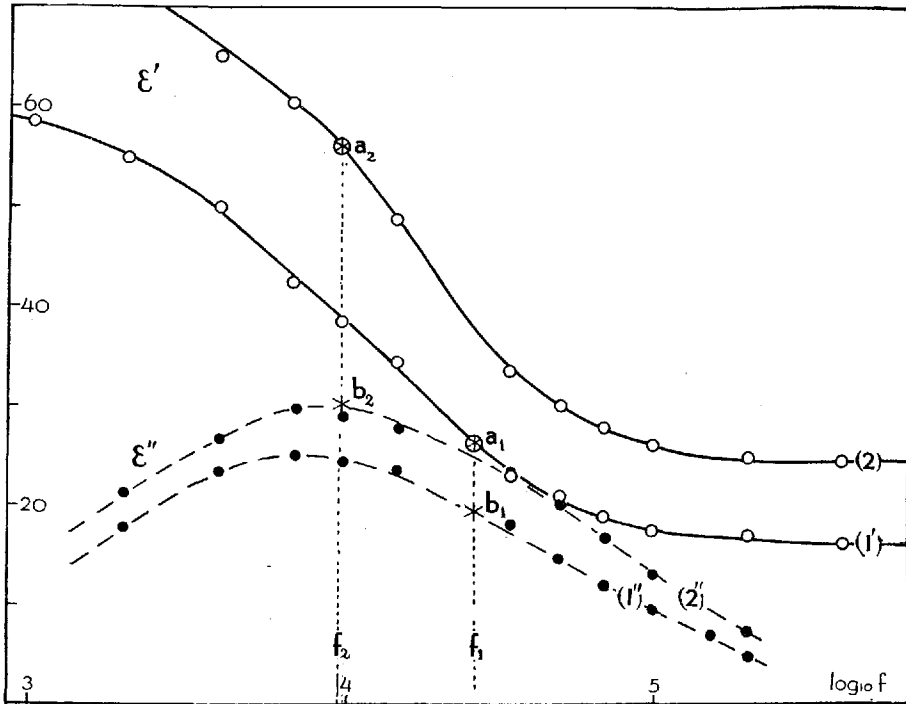

Fig. 16 Curves $\epsilon' - \log f$, $\epsilon'' - \log f$ of pure snow before and after it is soaked with mineral oil. (1), (1'): before soaking; (2), (2'): after soaking.

But yet it is not certain that the ice of the snow used in the present experiment was exactly of the same character as the ice of distilled water. In this way the present authors consider that the experimental results described above concerning the relative positions of points a_1 , a_2 , b_1 , b_2 are to be taken as an affirmation, even if weak, for WIENER's postulate rather than as a negation of it.

(2) *The dielectric constant of wet snow and the content of free water in it.* It was shown in Fig. 6 that the dielectric constant of wet snow decreased when the temperature was lowered below 0°C so as to freeze the free water contained in the snow. The relative change in the dielectric constant accompanying the freeze was rather large not only at low frequencies but also at high ones.

It is generally not an easy matter to determine the free water content w of wet snow and it is desirable to find a convenient way useful for that determination (13), (14). The change in the dielectric constant described above will answer that purpose if some relation can be found between that change and w . The present authors measured on many samples of wet snow both the free water content w and the change $\Delta\epsilon_0$ which was brought about in their optical dielectric constant ϵ_0 by the freeze, and found a simple relation to exist between them. The static dielectric

constant ϵ_s may be more suitable for the purpose than ϵ_o since ϵ_s is changed more largely than ϵ_o by freezing. But ϵ_s is so greatly influenced by the impurities contained in the snow as to be entirely useless while ϵ_o is almost perfectly independent of them.

The wet snow was packed into the electrical condenser so as to have the density 0.5 gr/cm^3 within it. Since the free water content w is defined as the ratio of the amount of water contained to the total weight of the wet snow, w suffers no alteration from the packing. The electrical condenser used in this case was of the same construction as that shown in Fig. 4 but was smaller than that. It had a volume $15 \times 14.3 \times 5 = 1073 \text{ cm}^3$ and showed an electric capacity $C_o = 33 \text{ cm}$ when empty. After having been subjected to the dielectric measurement, the condenser containing the wet snow was cooled down to -11°C and the measurement was made on it once more. The frequency f of the applied electric force was 3483 KC and the difference between the dielectric constants measured before and after the lowering of temperature gave the value of $\Delta\epsilon_o$. It was not always possible to pack the wet snow to just the density 0.5 gr/cm^3 . But $\Delta\epsilon_o$ was found to increase respectively by 0.36 and 0.47 in the cases of soft and granular snow as the packed density ρ' of wet snow was increased by 0.1 gr/cm^3 . By the use of this relation between $\Delta\epsilon_o$ and ρ' the measured value of $\Delta\epsilon_o$ was converted to the one which $\Delta\epsilon_o$ should have at $\rho' = 0.5 \text{ gr/cm}^3$. The temperature of the snow after it had been frozen was of no importance because the optical dielectric constant of ice does not depend on temperature. The present authors used the temperature -11°C for the sake merely of experimental convenience.

The free water content w was determined by separating the water from the snow by a hand-driven centrifuge (15), (16). The wet snow was put into a glass tube narrowed at one of its ends to a graduated thin tube and was placed within the container C of the centrifuge as shown in Fig. 17. A celluloid tube D covered the container C with a clearance filled with snow between them. The latter snow prevented the wet snow in the glass tube from melting while the centrifuge was rotating. The water separated from the snow by the centrifugal force gathered into the graduated tube to be measured in amount by the graduated scale. The rotating speed of the centrifuge was 800 rpm and subjected the wet snow to the centrifugal force of strength 10^5 cm/sec^2 or $100 g$. The time of rotation was half a minute.

In Fig. 17, $\Delta\epsilon_o$ corrected to the density 0.5 gr/cm^3 is plotted against the observed value w' of the free water content. The observed points lie near a straight line but that line does not pass through point O' where w' is zero. This is contradictory because the snow with no free water content should give zero value of $\Delta\epsilon_o$. But this contradiction will be removed if it is noticed that there remained some water in the snow non-separable by the centrifugal force. Indeed, when two samples taken from one and the same wet snow were subjected to the centrifugal

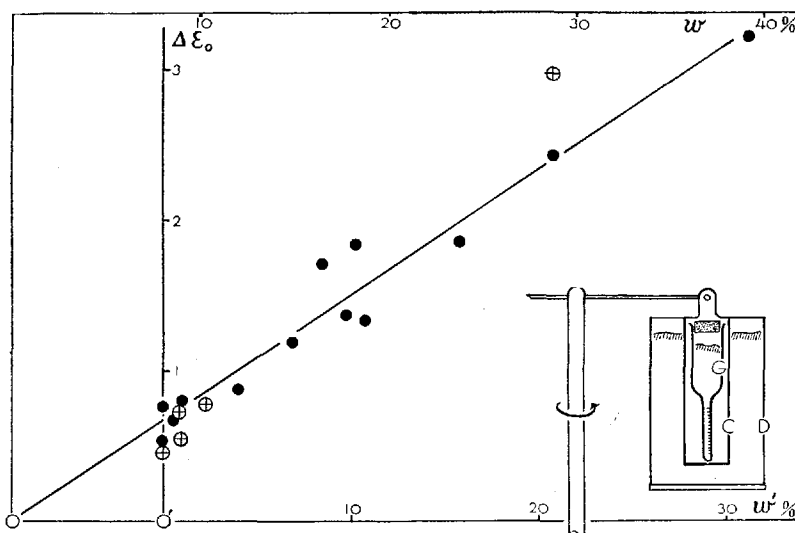

Fig. 17 $\Delta\epsilon_0$ (the change in the optical dielectric constant accompanying the freezing of wet snow) versus w (the free water content of the wet snow). $\Delta\epsilon_0$ was determined under the condition that the wet snow had density 0.5 gr/cm^3 within the electric condenser. Otherwise the measured $\Delta\epsilon_0$ was corrected to that density. w' graduated along the bottom line shows the uncorrected value of w as it was observed by use of the hand-driven centrifuge. Cross in circle: soft snow. Solid circle: granular snow.

The figure in the right lower corner illustrates the rotating part of the centrifuge used.

separation, one by the above hand-driven centrifuge and the other by a motor-driven one ten times more powerful, w' turned out to differ in the two cases. The motor-driven centrifuge separated more water than the hand-driven one did: free water content given by the former was always 5–6% larger than that obtained by the latter. This indicates that $w'=0$ does not mean the true absence of free water. If the true value of the free water content is denoted by w , it should be counted from point O at which the above straight line crosses the w' -axis in Fig. 17. Then the relation between w and $\Delta\epsilon_0$ represented by that line is given by

$$w = (6/5) \Delta\epsilon_0 \% .$$

Summary

The dielectric constant ϵ' and loss factor ϵ'' were measured on a number of snow samples for the frequency f of alternating electric force ranging from $\frac{1}{2}$ KC to 1 MC. The impurities which were without exception contained within the snow made its dielectric properties very complicated at the low values of f . The present authors avoided such a complexity by considering an imaginary snow which was

supposed to have lost ion-conductivity arising from the impurities. The character of the imaginary snow could be determined by the aid of the anticipation that $\epsilon' - \epsilon''$ curve of the actual snow would take the form of a complete half circle if the ion-conductivity were eliminated from it. Then it was shown that ϵ' and ϵ'' of the imaginary snow could, even if approximately, be expressed in dependence on f by DEBYE'S formulae (5), (6) in the text. That is to say, the dielectric properties of the imaginary snow should be specified by the three characteristic constants, static and optical dielectric constants ϵ_s , ϵ_o and relaxation time τ . The values of ϵ_s and ϵ_o determined on many samples of snow having different density ρ were found to lie within rather narrow bands in the $\epsilon_s - \rho$ plane and the $\epsilon_o - \rho$ plane respectively. The relationships between ϵ_s , ϵ_o and ρ were formulated by the use of O. WIENER'S theory which is based on the conception that the geometrical configuration of ice within the snow can to some extent be specified by a number called *Formzahl* u . The values u_s , u_o of u for the static and optical dielectric constants were found respectively to be

$$25 > u_s > 10, \quad 10 > u_o > 2.5.$$

No definite relationship could be found between τ and ρ ; τ was generally a few tenths of the relaxation time τ_i of ice at the same temperature.

Some comments were made on the physical meaning of u . The ice in snow is always constructed so as to be more or less continuous both parallel and perpendicularly to the direction of the applied electric force. It was concluded that u increases with the development of the parallel continuations while the perpendicular continuations tend to diminish the value of u . The observed fact that the relaxation time of snow was shorter than that of ice was explained to have arisen from the existence of the perpendicular continuations within the snow. It was proved theoretically that the ice comprising the perpendicular continuations should have its proper relaxation time much reduced.

When wet snow was cooled down to below 0°C, a change $\Delta\epsilon_o$ was produced in its optical dielectric constant due to the freezing of free water contained in it. A linear relation was found to hold between $\Delta\epsilon_o$ and the free water content w which the wet snow had had before the cooling.

References

"T. K." in the following is the abbreviation for "Teion-Kagaku" (Low Temperature Science), a scientific publication written in Japanese, issued by the Institute of Low Temperature Science, Hokkaido University, Sapporo, Japan.

- (1) Zyungo YOSIDA and Daisuke KUROIWA 1949 On a number useful for representing the form of ice grains composing snow. (in Japanese) Journ. of Japanese Soc. of Snow and Ice, 11, 1-5.
- (2) Daisuke KUROIWA 1951 The dielectric behavior of snow cover. T. K. 8. 1-58.

- (3) C. P. SMYTH and C. S. HITCHCOCK 1932 Dipole polarisation in crystalline solids. *J. A. C. S.* 54, 4631-4647.
- (4) F. HUMBEL, F. JONA and P. SCHERRER 1953 Anisotropie der Dielektrizitätskonstante des Eises. *Helvetica Physica Acta*, 26, 17-32.
- (5) H. WINTSCH 1932 Über Dielektrizitätskonstante, Widerstand und Phasenwinkel des Eises. *Helvetica Physica Acta*, 5, 126-144.
- (6) M. J. ERRERA 1924 La dispersion des ondes herziennes dans les solides au voisinage du poin de fusion. *J. de Phys.* 5, 304-311.
- (7) E. J. MURPHY 1934 The temperature dependence of relaxation time of polarization in ice. *Trans. of Electrochem. Soc.*, 65, 133-142.
- (8) Gorow WAKAHAMA 1957 The sea-salt crystals found in the residuals of individual rain drops, graupels and snowflakes. I. *T. K. (physics)* 16, 211-226.
- (9) W. A. CUMMING 1952 The dielectric properties of ice and snow at 3.2 centimeters. *Journ. of Appl. Phys.* 23, 768-773.
- (10) Otto WIENER 1910 Zur Theorie der Refraktionskonstanten. *Berichte über die Vorlesungen der Königlich Sächsischen Gesellschaft der Wissenschaften zu Leipzig. Mathematischphysikalische Klasse*, 62, 256-277.
- (11) K. W. WAGNER 1914 Erklärung der dielektrischen Nachwirkungsvorgänge auf Grund Maxwellscher Vorstellungen. *Archiv für Elektrotechnik*, 2, 371-387.
- (12) LORD RAYLEIGH 1892 On the influence of obstacles arranged in rectangular order upon the properties of a medium. *Phil. Mag.* 34, 481-502.
- (13) R. W. GERDEL 1954 The transmission of water through snow. *Trans. American Geophysical Union*, 35, 475-485.
- (14) G. P. WILLIAMS 1956 A field determination of free water content in wet snow. Research paper No. 26 of the Division of Building Research, National Research Council, Canada.
- (15) Masao KURODA and Iwao FURUKAWA 1952 Measurement of water content of snow-deposit. *Journ. of Japanese Soc. of Snow and Ice.* 13, 144-152.
- (16) Hirobumi OURA and Seiiti KINOSITA 1954 Measurement of free water content in snow. *T. K. (physics)* 12, 61-72.

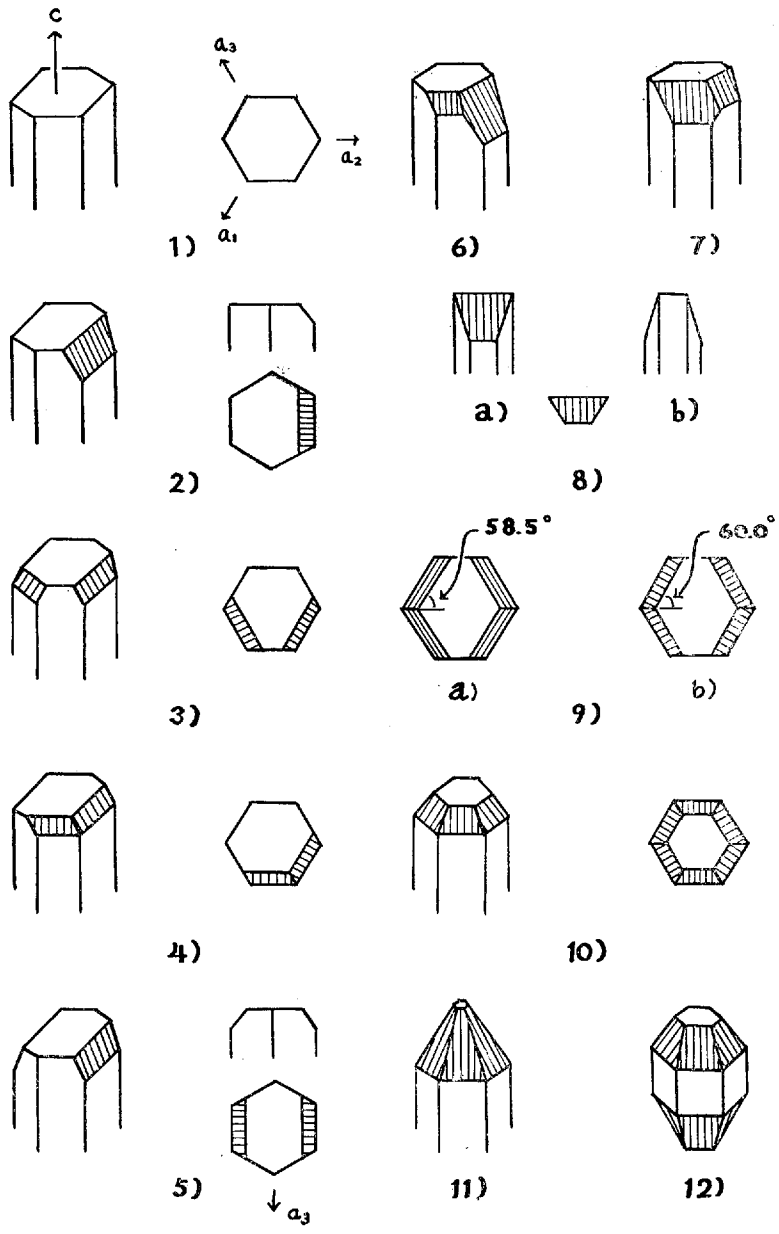

Fig. 3.