



HOKKAIDO UNIVERSITY

Title	Crystallographic Orientation of Frozen Droplets on Ice Surfaces
Author(s)	HIGUCHI, Keiji; 樋口, 敬二; YOSIDA, Tatekatu et al.
Description	International Conference on Low Temperature Science. I. Conference on Physics of Snow and Ice, II. Conference on Cryobiology. (August, 14-19, 1966, Sapporo, Japan)
Citation	Physics of Snow and Ice : proceedings, 1(1), 79-93
Issue Date	1967
Doc URL	https://hdl.handle.net/2115/20287
Type	departmental bulletin paper
File Information	1_p79-93.pdf



Crystallographic Orientation of Frozen Droplets on Ice Surfaces

Keiji HIGUCHI

樋口敬二

Water Research Laboratory, Nagoya University, Nagoya, Japan

and

Tatekatu YOSIDA

由田建勝

Sapporo Meteorological Observatory, Japan Meteorological Agency, Sapporo, Japan

Abstract

Photogrammetric observations were made on natural snow crystals composed of an assemblage of crystallographically single crystals. It was found in the case of certain types of these crystals that crystallographic relations exist between the base crystal and the secondary branches developed from it. The formation mechanism of such secondary branches is discussed on the basis of geometrical studies on lattice matching between crystal planes of ice, and on experimental work on the crystallographic orientation of frozen droplets on ice surfaces.

I. Introduction

As is seen in the photographs of natural snow crystals of the spatial dendritic type with a stellar base (Nakaya, 1954), the growth direction of secondary dendritic branches is at an appreciable angle to the plane of the base crystal. This means that the crystallographic orientation of the former is different from that of the latter.

Nakaya (1954) considered that such secondary branches grew from an ice nucleus attached to a snow crystal. In addition, Kumai (1964) proposed another theory in which the growth of the secondary branch is generated from an ice fog particle attached to a snow crystal. It may be inferred from these two mechanisms that the crystallographic orientation of a secondary branch should have no dependency on that of the base crystal, but should depend largely on how the ice nucleus or ice fog particle is attached to the crystal.

Recently, Hallett (1965) proposed a new theory in which he stated that a frozen water droplet accreted by a snow crystal can grow as a secondary branch. Now since the crystallographic orientation of frozen water droplets should have some dependency on that of the substrate, a crystallographic relation should exist between the secondary branch and the base crystal. In this respect Hallett's theory differs from those of Nakaya and Kumai.

The present work was undertaken in an attempt to determine which of the three theories provides a better explanation of the formation of secondary branches.

II. Crystallographic Orientation of Secondary Branches of Snow Crystals

a) Secondary branches developed from the center of the base crystal

The simplest type of spatial dendritic crystal with a stellar base is that with one or two branches developing from the center of the base crystal, as seen in Figs. 1 and 2, reproduced from Photo. 602 and Fig. 108 in Nakaya's book. If the shape of these

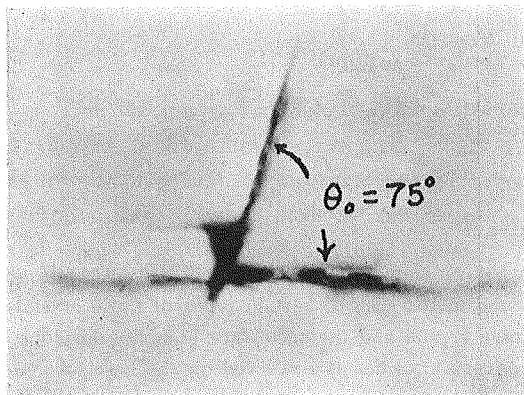

Fig. 1. (Nakaya, 1954) $\times 30.5$

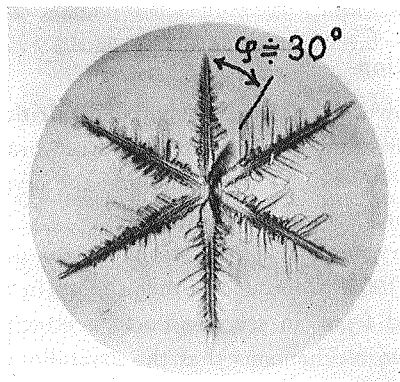
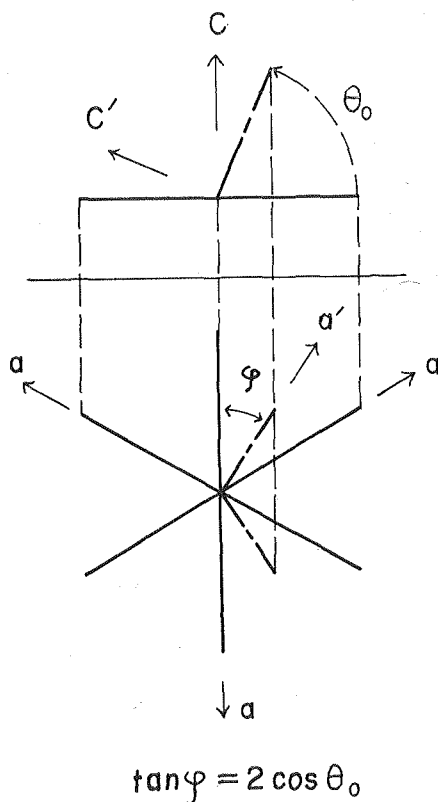

Fig. 2. (Nakaya, 1954) $\times 16.5$



$$\tan \varphi = 2 \cos \theta_0$$

Fig. 3. Projection of spatial dendritic crystal

crystals is as shown in Fig. 3, the geometrical relation between θ_0 and φ (Higuchi, 1957) should be

$$\tan \varphi = 2 \cos \theta_0 .$$

Since the values of θ_0 and φ in Figs. 1 and 2 are a solution of this equation, it can be said for these crystals that one of the a -axes of the secondary branch is parallel to that of the base crystal, in addition c -axis of the former inclines at a 75° angle to that of the latter. Such a crystallographic relation could be understood if the (0001) plane of the secondary branch is combined with the $(20\bar{2}1)$ plane of the base crystal or vice versa.

A similar shape of snow crystal to those described above might be a spatial

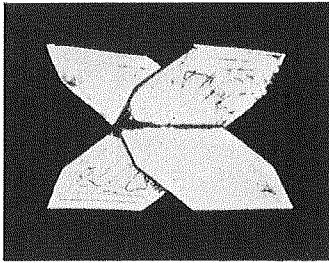

Fig. 4. (Bentley, 1931)

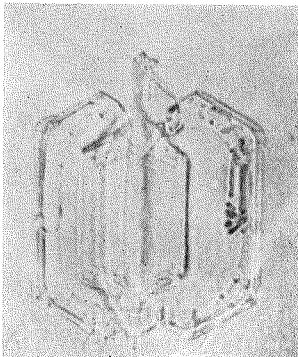

Fig. 5. (Nakaya, 1954) $\times 42.5$

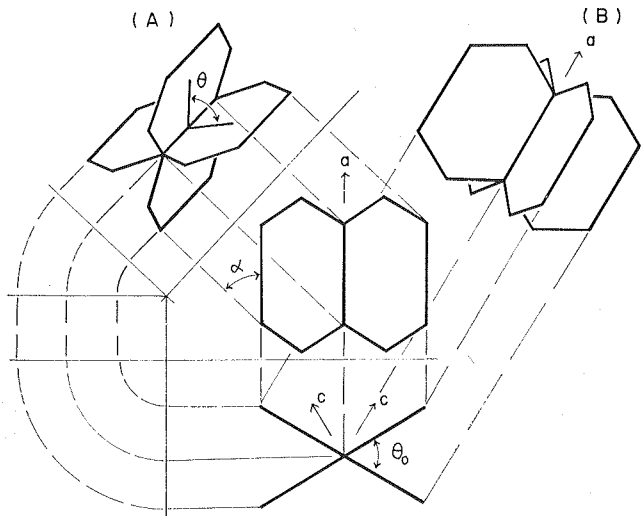

Fig. 6. Projection of spatial combination of plates

combination of plates shown in Figs. 4 and 5, reproduced from p. 210 in Bentley's (1931) book and Fig. 153 of Nakaya's book. These seem to be projections of the same shape of crystal as shown in Fig. 6.

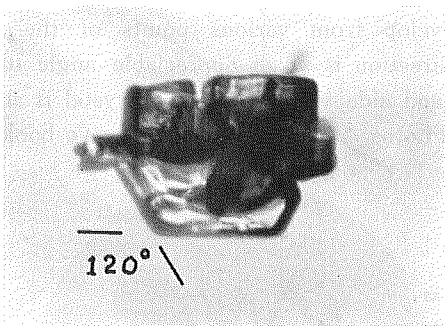

Fig. 7. (Higuchi, unpublished) $\times 68$

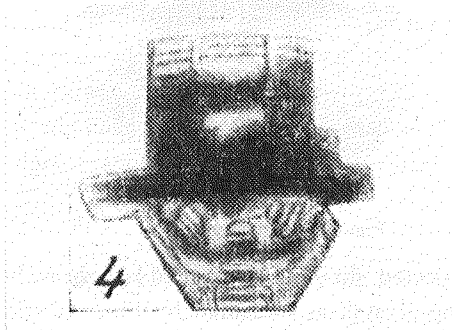

Fig. 8. (Klinov, 1960)

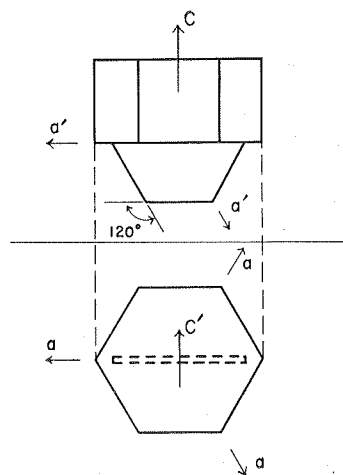

Fig. 9. Projection of combination of column and plate

Snow crystals in Figs. 7 and 8, are examples of secondary plate branches grown from a columnar crystal, Fig. 8 being reproduced from a paper by Klinov (1960, p. 50). As shown in Fig. 9, it seems to be clear that one of the a -axes of the plate is parallel to that of the column, and the c -axes of these cross each other perpendicularly. Such a relation can be obtained if the (0001) plane of the former is combined with the (10 $\bar{1}$ 0) plane of the latter.

Figures 10 and 11 reproduced from Photos. 679 and 705 in Nakaya's book, are examples of snow crystals which are composed of two columns or needle crystals, their c -axes

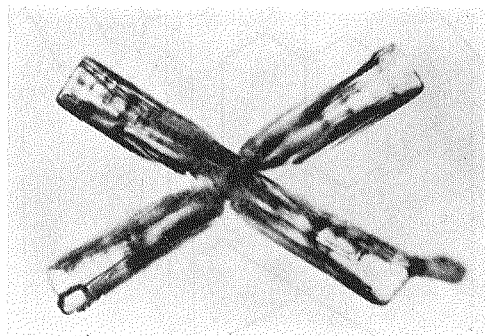

Fig. 10. (Nakaya, 1954) $\times 55.5$

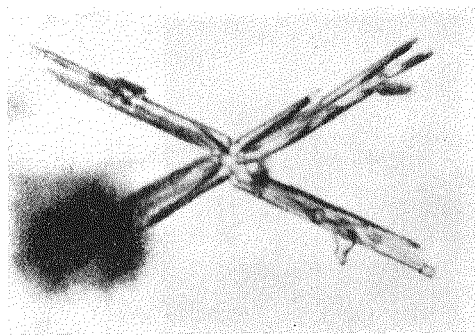

Fig. 11. (Nakaya, 1954) $\times 47.5$

cross at 58.5° approximately. Such a relation can be explained by a combination of the (0001) plane of one elementary crystal with the (1 $\bar{2}$ 11) plane of the other.

b) Secondary branches developed from main branch of base crystal

When secondary dendritic branches develop from various points of the main branches of the base crystal, their growth direction is at an appreciable angle to the base crystal plane. An example of the plan and side views of such a crystal is shown in Figs. 12 and 13, after reproduction from Photos. 567 and 568 in Nakaya's book. It

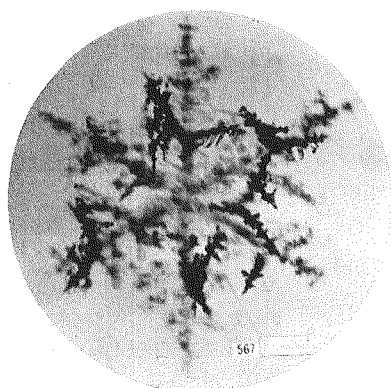

Fig. 12. (Nakaya, 1954) $\times 16$

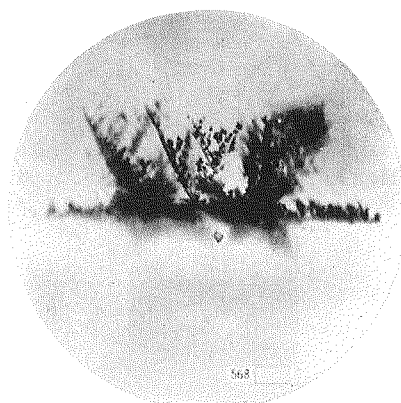

Fig. 13. (Nakaya, 1954) $\times 16$

was found in Figs. 14 and 15, that the projected direction of secondary branches is perpendicular to one of the a -axes of the base crystal, as indicated by Figs. 16 (A) and (B) separately. Though the combination of crystal planes is not known yet, this is an

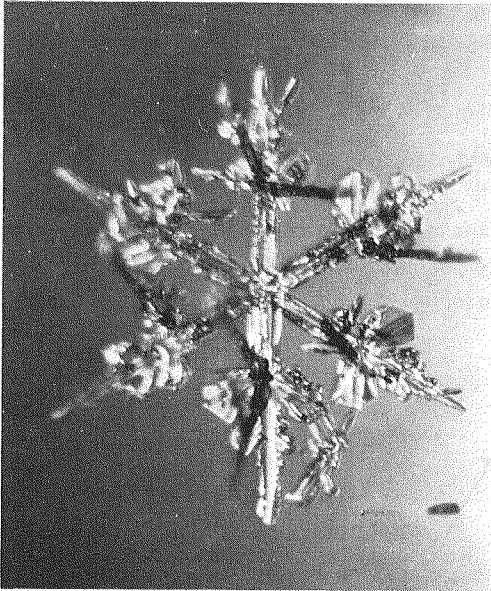

Fig. 14. (Higuchi, unpublished) $\times 26.5$

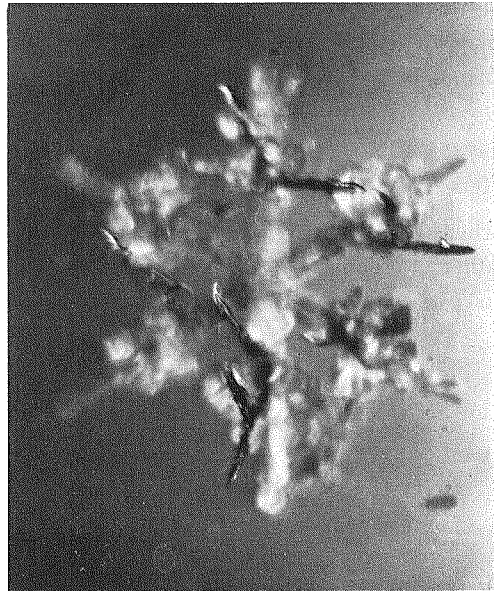

Fig. 15. (Higuchi, unpublished) $\times 26.5$

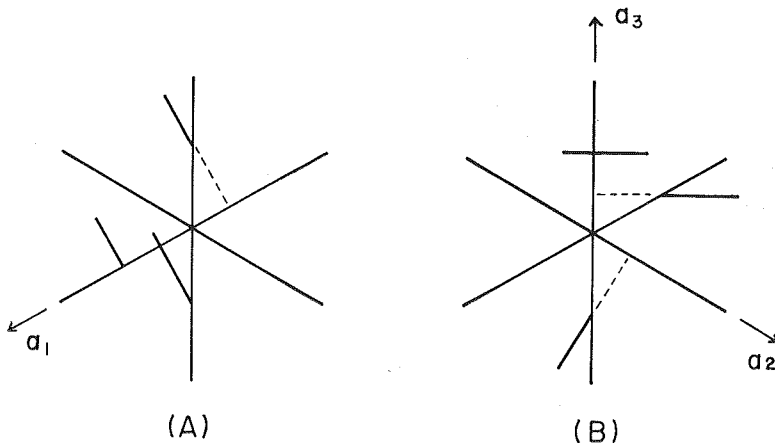

Fig. 16. Direction of secondary branches of spatial dendritic crystal

important result for discussion on the growth mechanism of secondary branches, since they show a systematic orientation even when the generating point of growth is different in each case.

In summary, it can be said that some crystallographic relations exist between the secondary branches and their base crystal.

III. Lattice Matching between Two Crystal Planes of Ice

The photogrammetric study on snow crystals described in section I indicates that the formation of secondary branches might be explained by ice crystal growth from frozen droplets attached to the crystal, as proposed by Hallett. If so, the growth of

secondary branches can be considered in the same way as an epitaxial growth of ice crystals on a foreign solid surface. Therefore, the lattice matching between two crystal planes of ice was examined as follows.

The lattice misfit between two crystal planes of ice, δ , can be given by

$$\delta = \left| \frac{a - a_0}{a_0} \right|,$$

where a is a lattice vector of one crystal plane and a_0 the corresponding vector of the other. When some of the crystal planes are matched with the basal plane as shown in Fig. 17, the lattice misfit in the direction of a -axis, $\delta_{\parallel a}$, and that perpendicular to

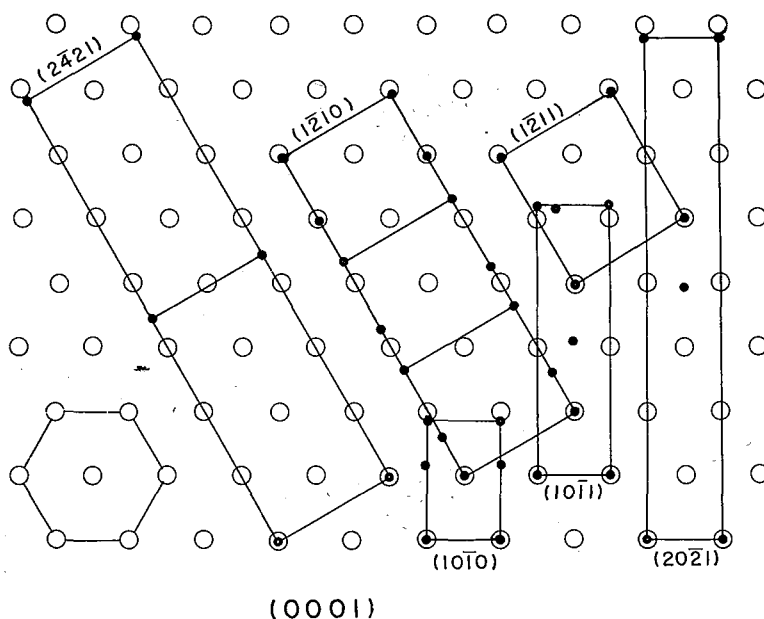

Fig. 17. Basal matching with crystal planes of ice

a -axis, $\delta_{\perp a}$, can be calculated. The results are seen in Fig. 18, in which the shape of snow crystals expected from these matchings are also shown. Figure 19 shows the results for the matching of a prism plane with others.

The calculated values of basal and prism misfit given above are of the same order as that between ice and the most active nucleating substances such as AgI, PbI₂ and CuS. It is possible, therefore, that freezing of supercooled droplets on an ice surface, as well as ice crystal nucleation on foreign substances, would occur under the conditions of lattice matching given above.

IV. Experimental Studies on Crystallographic Orientation of Frozen Droplets on Ice Surface

In order to study the possibility of occurrence of freezing of water droplets under the lattice matching described in the previous section, simple experiments were carried

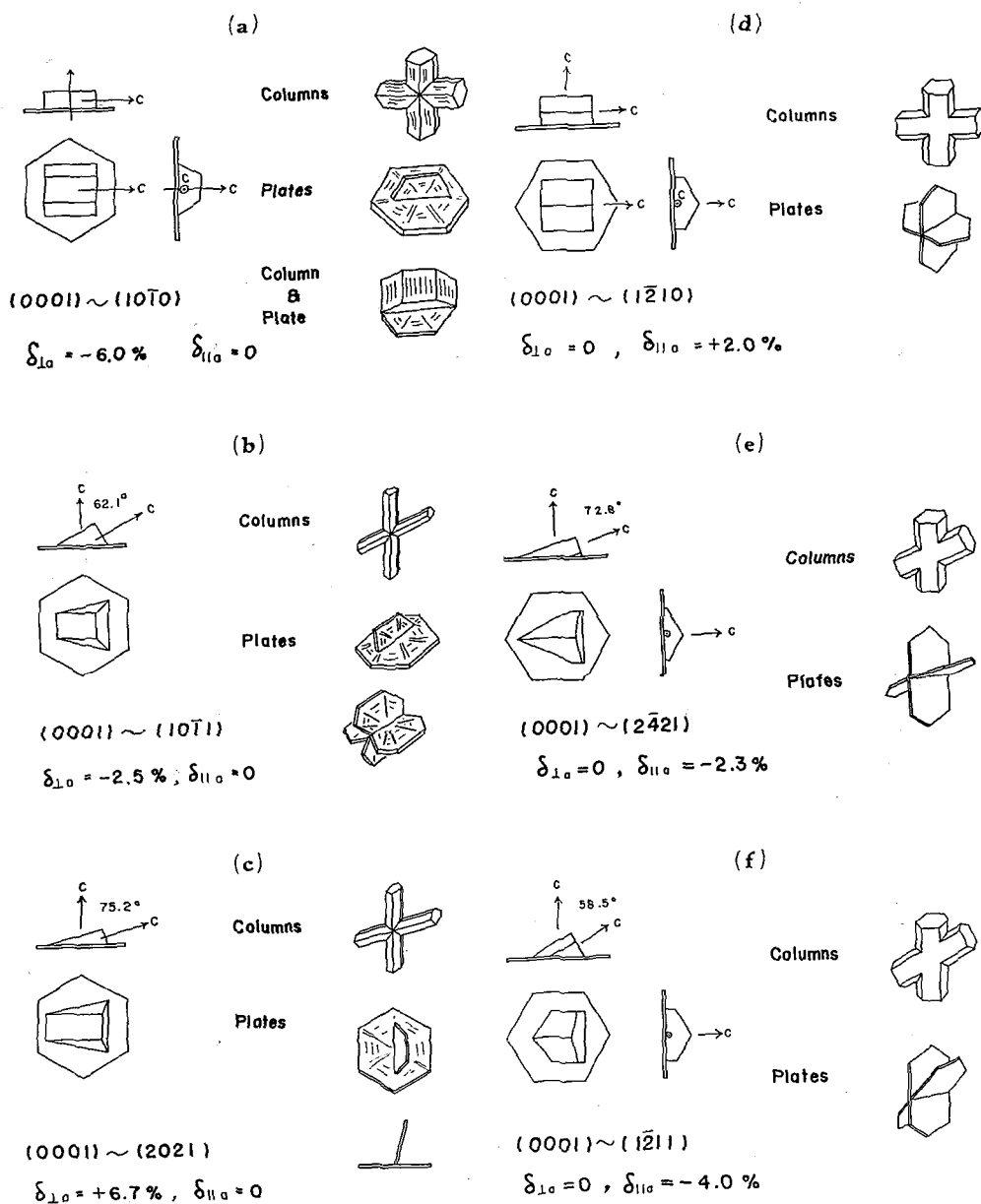

Fig. 18. Projection of combination of plate and column and their lattice misfits

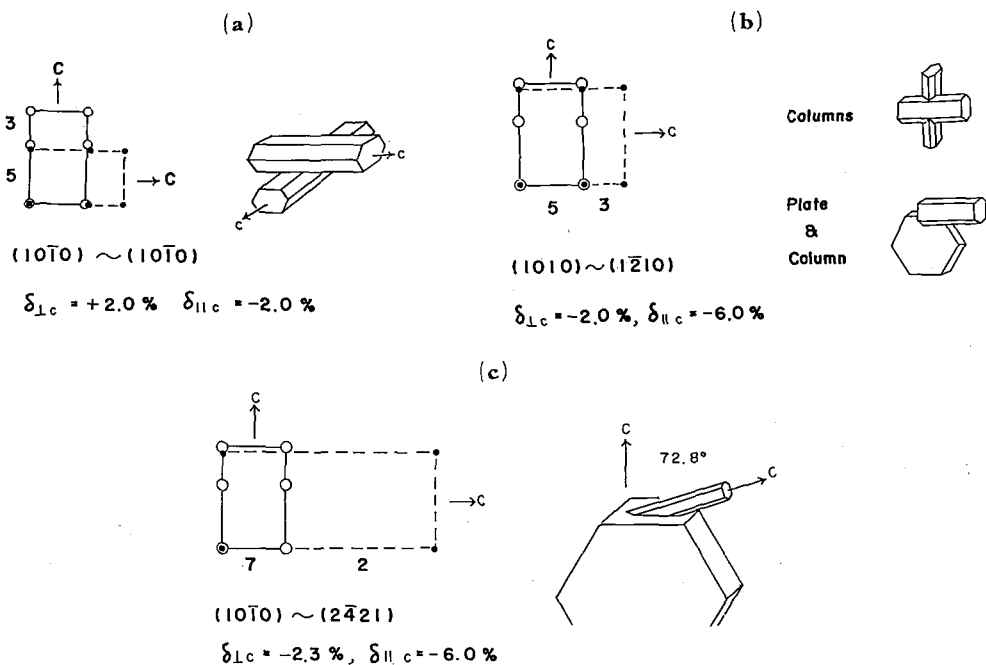

Fig. 19. Prism matching with crystal planes of ice

out in the cold chamber by using the apparatus shown schematically in Fig. 20.

Supercooled droplets were sprayed on the surface of a hoar crystal of skeleton structure as a substrate. Following this treatment, water vapor was supplied to the hoar crystal placed in an apparatus similar to that used for the artificial production of snow crystals. Under suitable conditions of temperature and vapor supply, the frozen droplets on the hoar crystal grew as ice crystals of column or plate type. The direction of crystal-axes of frozen droplets were determined from the shape of ice crystals grown from these droplets.

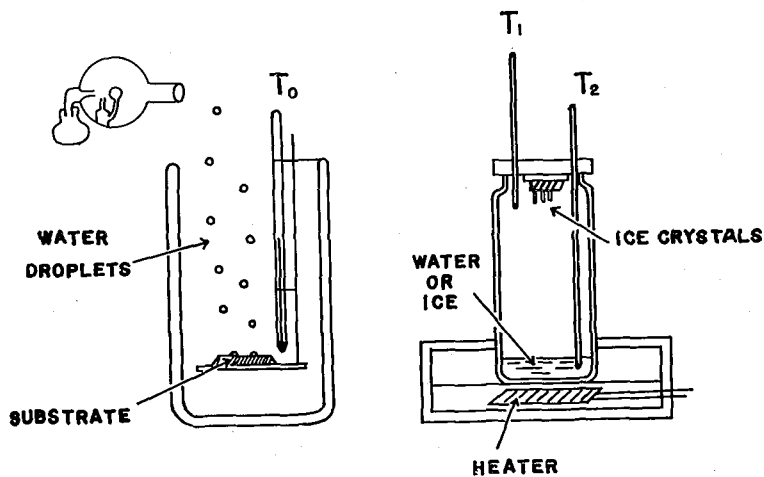

Fig. 20. Experimental apparatus

The shape of many of the ice crystals grown from the frozen droplets indicates that the freezing of droplets occurred under conditions of no lattice misfit, namely, the same crystallographic orientation as that of the substrate. But, as will be described below,

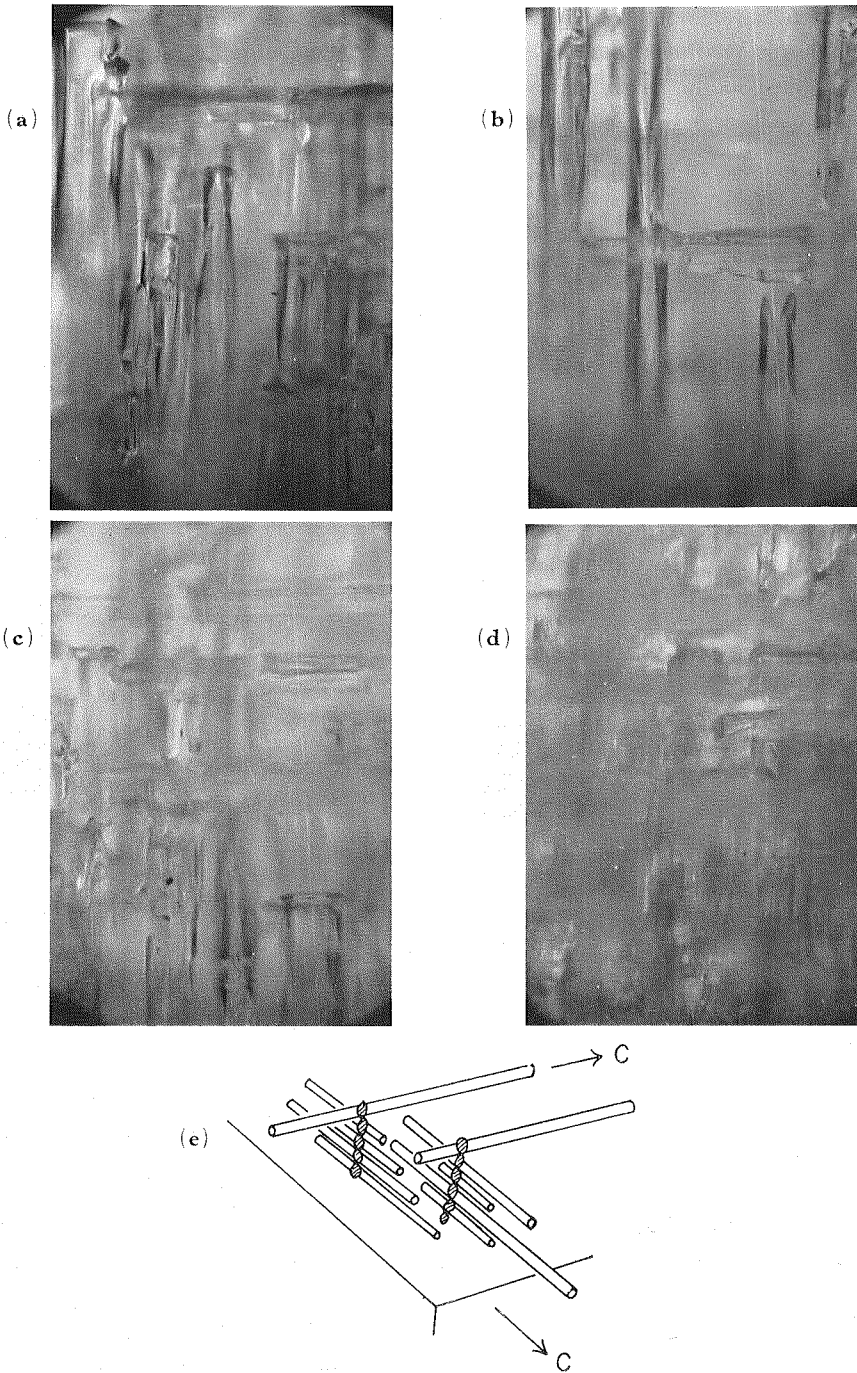

Fig. 21. $\times 34$

some of them showed an occurrence of freezing under conditions of lattice matching described in the previous section.

a) Ice crystals with c -axis perpendicular to that of the substrate

When the air temperature is almost -8°C , ice crystals grew as hollow prisms; this was suitable for viewing the direction of their c -axes. Figure 21 shows a series of photographs of the hollow prisms grown from frozen droplets over an ice surface with a horizontal c -axis, taken at different focusing points from the top of the ice crystals to the substrate. The number of sprayed droplets was so numerous in this case that several of them froze as a pillar like rime growth, as shown in the sketch in Fig. 21. It can be easily seen from these photographs that many of the ice crystals grew with the same c -axis orientation as that of the substrate, but some of them were seen with the c -axis perpendicular to the substrate.

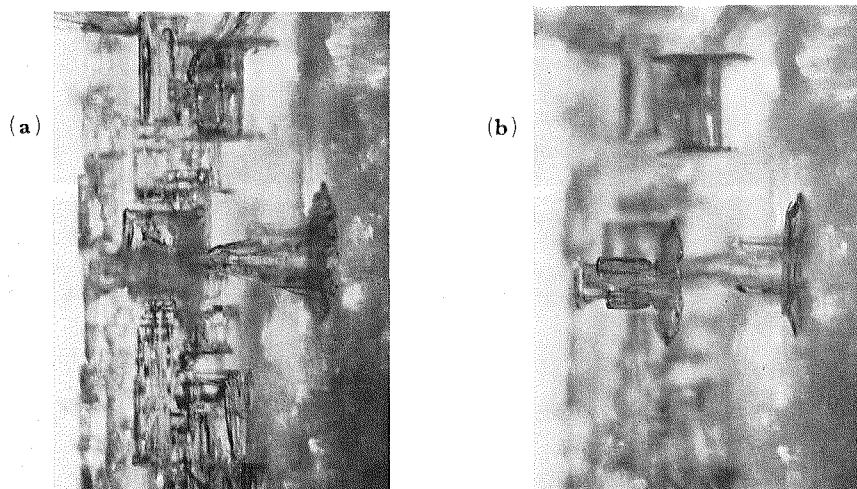

Fig. 22. $\times 18$

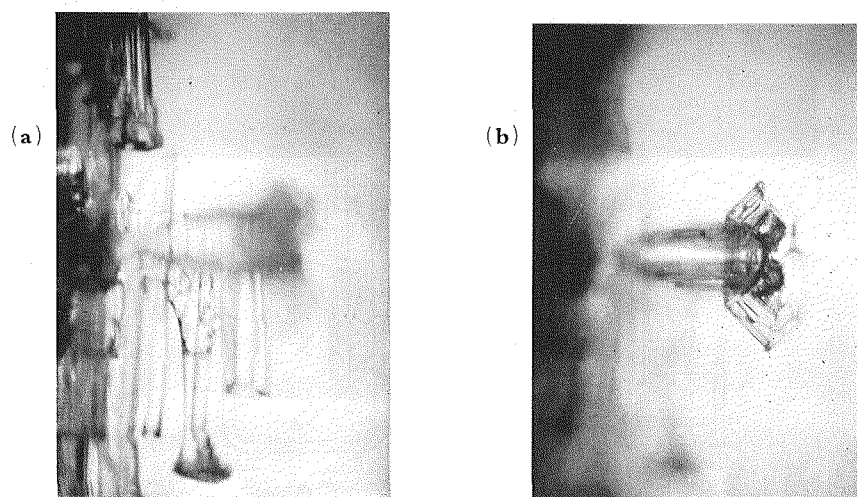

Fig. 23. $\times 17.5$

Figure 22 shows another example of ice crystals similar to the above, but with a plate on the top of a hollow prism, that is to say the "Tsuzumi" type (Nakaya, 1954). It was found from the shape of the plate-part of the ice crystals that the c -axis direction of this crystal is perpendicular to that of the substrate and is also in parallel to one of the a -axes of the substrate. In addition the direction of one of the a -axes of the former is parallel to the c -axis of the latter. This crystallographic relation indicates the occurrence of lattice matching between (0001) and ($1\bar{2}10$) in Fig. 18 d, or between ($10\bar{1}0$) and ($10\bar{1}0$) in Fig. 19 a. Figure 23 is another example of a similar crystal.

Figures 24 and 25 are examples of ice crystal growth, different from that described above, when droplets were sprayed over a prismatic surface of hoar crystal. As seen in these photographs, the direction of the c -axis of the ice crystal is perpendicular to the c -axis of the substrate; in addition one of the a -axes of the former is perpendicular to the c -axis of the latter. This relation can be seen more clearly in Fig. 26, which shows ice crystal growth from frozen droplets on a basal surface of hoar crystal. The hexagonal plate in this photograph indicates the direction of the a -axes of the substrate. These crystallographic relations can be understood if the lattice matching between (0001) and ($10\bar{1}0$) occurred as shown in Fig. 18 a.

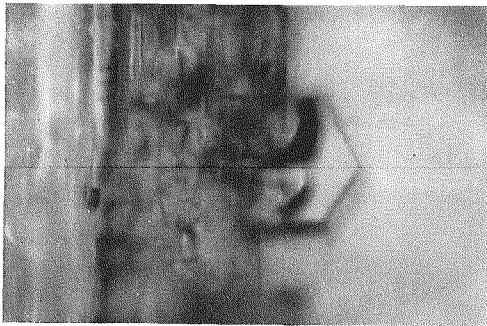

Fig. 24. $\times 64$

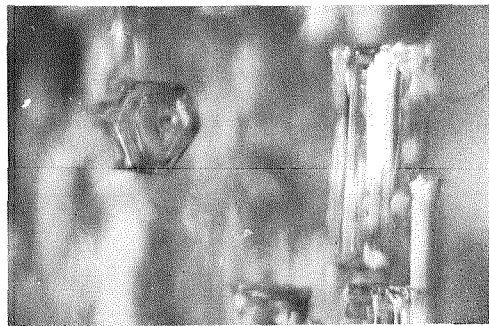

Fig. 25. $\times 71.5$

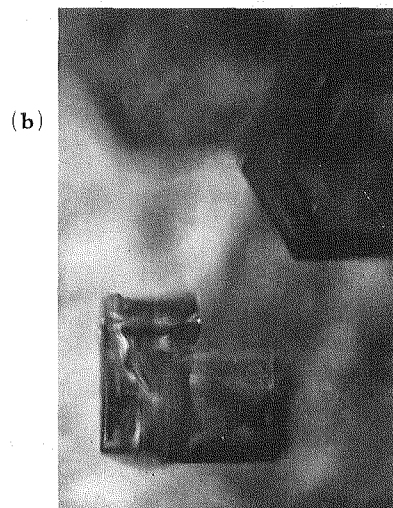
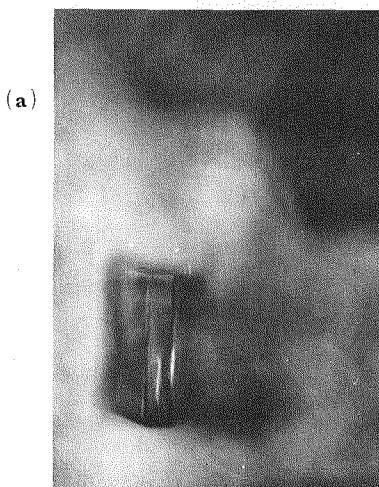

Fig. 26. $\times 39$

b) Ice crystal growth with c-axis inclined to that of substrate

When ice crystals grew from frozen droplets over a prismatic surface of hoar crystal, it was observed in some cases that their *c*-axes were at an inclined angle to that of the substrate, as shown in Figs. 27~29.

Since a prismatic surface of hoar crystal with skeleton structure is composed of basal and prism planes of ice as shown in Fig. 30, it can be expected that freezing

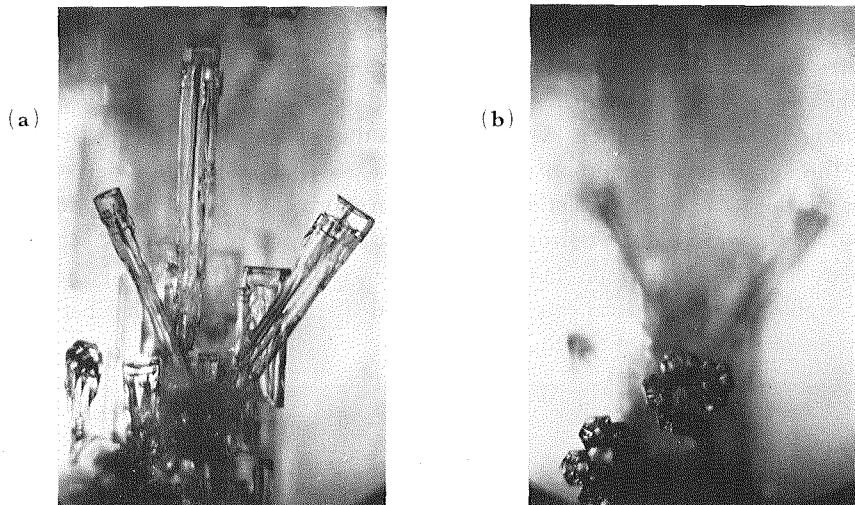

Fig. 27. $\times 12$

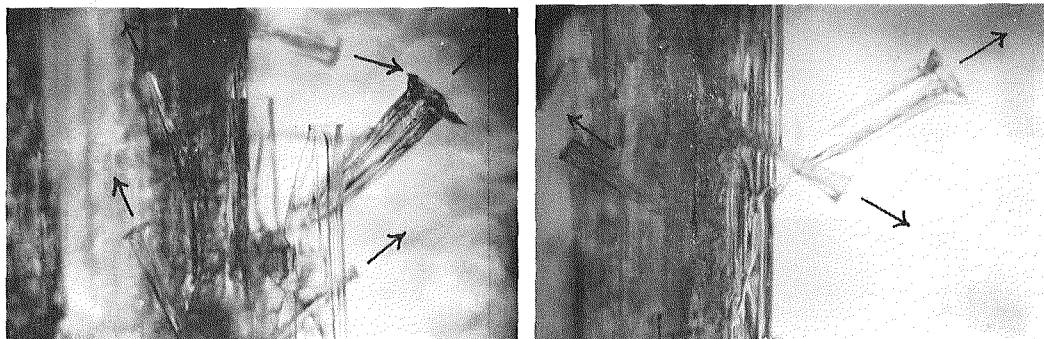

Fig. 28. $\times 12$

Fig. 29. $\times 14$

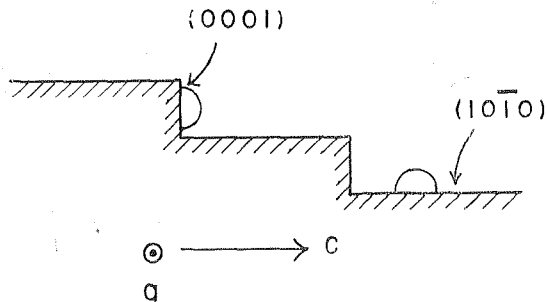

Fig. 30. Step of a prismatic surface of hoar crystal with skeleton structure

of supercooled droplets would occur on these two crystal planes. Therefore, the lattice matching was examined between these two planes and others than those described in section III. The prism matching was not so satisfactory, but the basal matching was fairly good as summarized in Table 1, when the matchings are made as shown in Fig. 31.

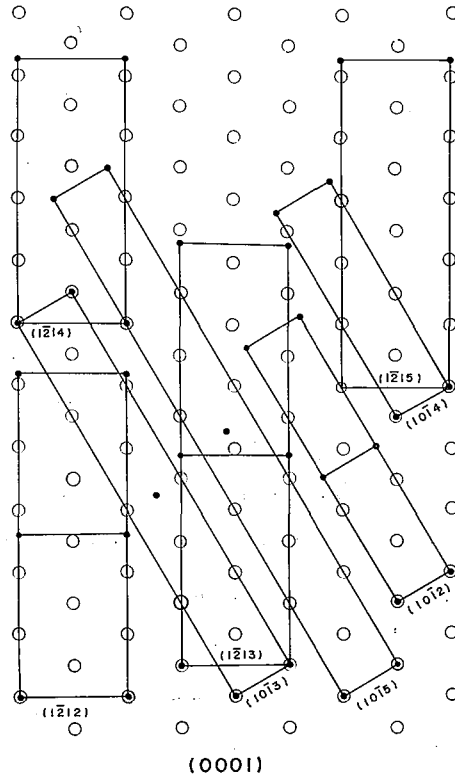

Fig. 31. Basal matching with crystal planes of ice

Table 1. Basal misfit and angle between *c*-axes

Crystal plane	$\delta_{\perp\alpha}$ (%)	θ_0 ($^\circ$)	Crystal plane	$\delta_{\parallel\alpha}$ (%)	θ_0 ($^\circ$)
(10 $\bar{1}$ 0)	- 6.0	90.0	(1 $\bar{2}$ 10)	- 2.0	90.0
(20 $\bar{2}$ 1)	- 2.5	75.2	(2 $\bar{4}$ 21)	- 2.3	72.8
(10 $\bar{1}$ 1)	+ 6.7	62.1	(1 $\bar{2}$ 11)	- 4.0	58.5
(10 $\bar{1}$ 2)	- 8.3	43.3	(1 $\bar{2}$ 12)	+ 3.0	39.3
(10 $\bar{1}$ 3)	+ 0.34	32.2	(1 $\bar{2}$ 13)	- 2.5	29.1
(10 $\bar{1}$ 4)	+ 10.6	25.2	(1 $\bar{2}$ 14)	+ 7.9	22.2
(10 $\bar{1}$ 5)	+ 6.9	20.4	(1 $\bar{2}$ 15)	+ 5.2	18.1

Figure 32 is the histogram of the measured angle between the *c*-axis of the substrate and that of ice crystals grown on one plane parallel to the *a*-axes of the substrate. It can be seen in this figure that the peaks of the measured angle correspond to basal

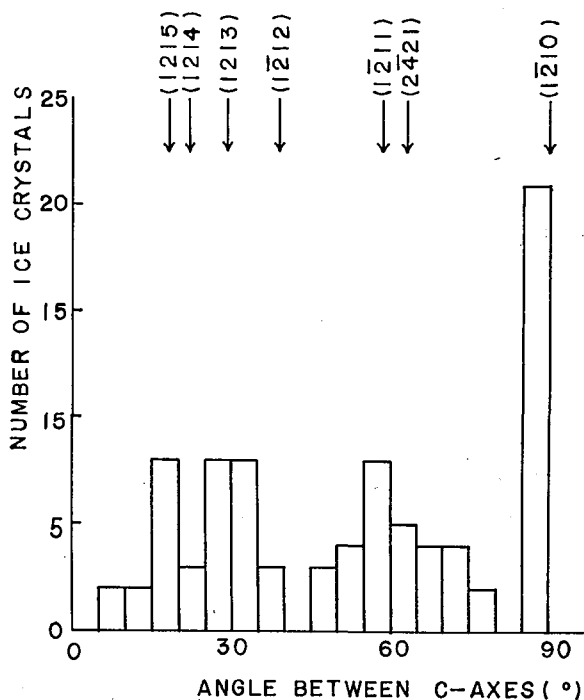

Fig. 32. Histogram of angle between c -axis of ice crystals and that of substrate

matching with $(\bar{1}\bar{2}11)$, $(\bar{1}\bar{2}13)$ and $(\bar{1}\bar{2}15)$. However, it might be necessary for this problem to be clarified further, since the correspondence as described above is not clear cut.

V. Conclusion

In conclusion, it may be said that crystallographic relations exist between the secondary branches and their base crystal, as well as between ice crystals grown from frozen droplets and their substrate. This result seems to support a formation mechanism of secondary branches in which the frozen droplet accreted with snow crystals grew as a branch, such as suggested by Hallett. However, this paper is concerned only with simple crystallographic relations; the use of a polarizing microscope as attempted by Magono and Suzuki (1964) for observing snow crystals might be used in the future for studying more complicated relations.

References

- 1) BENTLEY, W. A. and HUMPHREYS, W. J. 1931 Snow Crystals, McGraw-Hill Book Co., New York; 1962 Dover Publications, Inc., New York, 210 pp.
- 2) HALLETT, J. 1964 Experimental studies on the crystallization of supercooled water. *J. Atmos. Sci.*, **21**, 671-682.
- 3) HIGUCHI, K. 1957 Determination of the crystal face of ice by projection method. *J. Meteorol. Soc. Japan., Ser. II*, **35**, 254-256.
- 4) KLINOV, F. JA. 1960 Voda v Atmosfere pri Nizkikh Temperaturakh, Acad. Sci. USSR, 171 pp.

- 5) KUMAI, M. 1964 A study of ice fog and ice-fog nuclei at Fairbanks, Alaska. Part 1. *CRREL Res. Rept.*, **150**, 1-27.
- 6) MAGONO, C. and SUZUKI, S. 1964 The observation of snow crystals by the use of polarizing microscope. Presented to the Annual Meeting of the Japan Meteorological Society.
- 7) NAKAYA, U. 1954 *Snow Crystal, Natural and Artificial*, Harvard University Press, Cambridge, 308 pp.