



# HOKKAIDO UNIVERSITY

Title	Morphology of Frazil Ice
Author(s)	Michel, Bernard
Description	International Conference on Low Temperature Science. I. Conference on Physics of Snow and Ice, II. Conference on Cryobiology. (August, 14-19, 1966, Sapporo, Japan)
Citation	Physics of Snow and Ice : proceedings, 1(1), 119-128
Issue Date	1967
Doc URL	<a href="https://hdl.handle.net/2115/20290">https://hdl.handle.net/2115/20290</a>
Type	departmental bulletin paper
File Information	1_p119-128.pdf



# Morphology of Frazil Ice

Bernard MICHEL

*Department of Civil Engineering, Laval University, Quebec, P. Q., Canada*

## I. Introduction

Frazil ice appears in a supercooled flow. Its physical aspect starts changing from the moment it appears and that metamorphosis keeps on going as long as it exists. This article aims to examine in a general way the different morphological aspects of frazil ice in rivers.

## II. Frazil Appearance

We know that frazil ice is generally defined as the mass of ice crystals formed in a turbulent flow which is in a supercooled condition. What is less known is that the phenomenon of supercooling is seemingly universal for the beginning of the solid phase. Young (1910) says, that very rarely a liquid starts to crystallize at its normal temperature of solidification. There is always supercooling at the start of the solid phase.

Considerable supercooling (Michel, 1964) exists when snow, hail or sleet crystals are formed from water droplets in the clouds. The freezing temperature of motionless masses of water is generally many degrees centigrade below zero. Consequently it is not surprising to observe that ice crystals in rivers appear at water temperatures below  $0^{\circ}\text{C}$ .

In river sections with rapid flow, turbulence extends to the whole mass of water. Water temperature is then lowered outside a thin thermal boundary layer and, theoretically, frazil appears uniformly in the whole cross-section. In this case, however, the

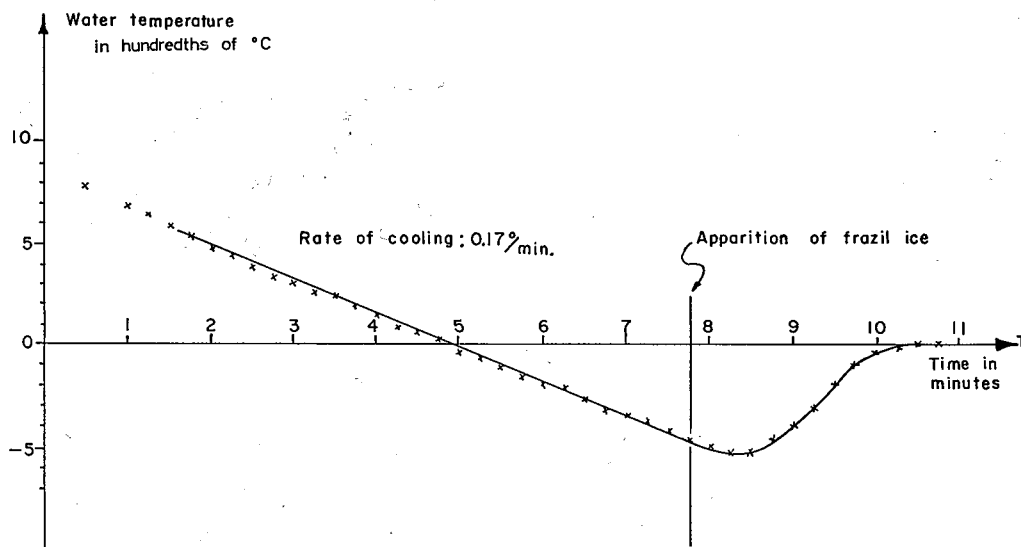
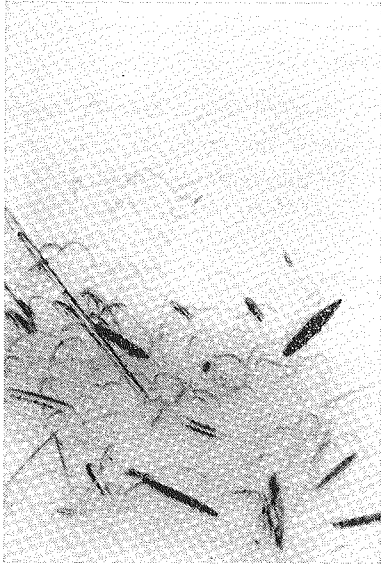

Fig. 1. Evolution of water temperature during the formation of frazil ice

minimum temperatures are only of the order of a few hundredths of a degree and on occasion of  $-0.1^{\circ}\text{C}$  (Altberg, 1936).

Let us consider water temperature evolution when frazil ice is formed. For that, it is useful to consider two approaches. One consists in following along the flow the same



Appearing frazil particles

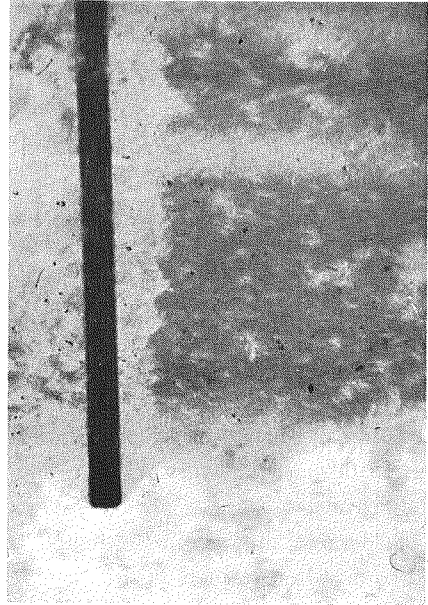

New frazil ice forming flocks and depositing on a steel rod

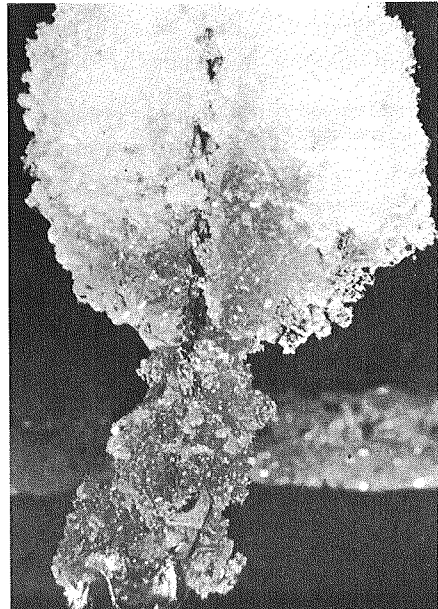

Agglomeration of new frazil flocks on a rope

**Fig. 2.** New frazil particles

volume of water, the other in studying temperature distribution along the flow.

Experiments made on frazil ice formation in an experimental flume at Laval University represent the first approach (Michel, 1963). A typical curve of water temperature evolution in function of time is shown in Fig. 1. The mass of water initially above  $0^{\circ}\text{C}$  is cooled at a constant rate. Water temperature reaches  $0^{\circ}\text{C}$  and keeps on cooling at the same rate for a few hundredths of a degree. The rate of cooling then starts to decrease until it rapidly becomes null. Water temperature has then reached its minimum point. As the rate of cooling decreases, small ice particles start to appear uniformly in the turbulent flow. Those particles are then too small to be seen by the naked eye, but their presence is revealed by the fact that they give good reflection to light. They rapidly grow and form ice spicules or disks whose largest dimension is of the order of a few tenths of an inch, the other dimensions being extremely small. Some of those particles are shown in Fig. 2. After water temperature has reached its minimum it returns to  $0^{\circ}\text{C}$ , first at a quick rate, and then more and more slowly. That gives to the curve a more or less asymptotic appearance as the temperature tends toward  $0^{\circ}\text{C}$ . During that period, the individual particles agglomerate to form vaporous flocks whose dimensions depend on the turbulence of the flow. Frazil ice production lasts for a few minutes only, and then no more particles of that type are produced. During the frazil ice formation period a considerable reserve of cold exists in the supercooled water. The potential of particle growth is high and that is why they form rapidly and agglomerate into flocks. We call frazil ice formed during that period, active frazil ice (Michel, 1963), to differentiate it with frazil ice that has already formed and evolved in the water whose temperature came back to the normal freezing point.

Let us now examine the temperature evolution along the axis of a river with the help of Fig. 3, considering the case of uniform flow with depth  $y_0$  and mean velocity  $v_0$ . If we suppose that the temperature at the chosen point of origin along the distance axis is constant, as is the rate of heat transfer towards the atmosphere per unit of water surface, the temperature curve is then similar to the one represented in Fig. 1. It only differs by a change in the abscissa:  $x = v_0 t$ . But this curve is much more representative

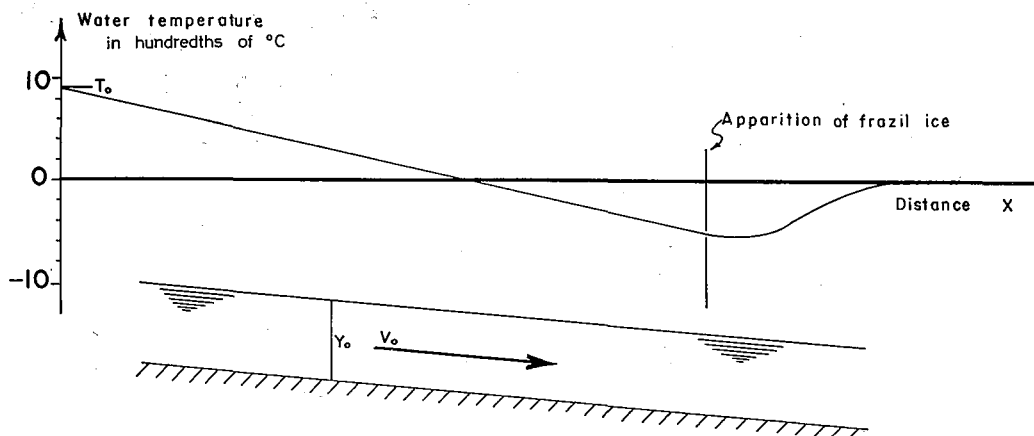

Fig. 3. Evolution of water temperature along the axis of a uniform flow

of frazil ice appearance in rivers. In this ideal case, frazil ice is produced indefinitely in the same zone and the point of its appearance is fixed. The zone of active frazil ice extends over a few hundred feet only. In nature the main difference comes from the continuous variation in the heat transfer process, because of atmospheric changes; one most important aspect of this being the abrupt and unexpected changes in wind conditions. A continuous lowering of atmospheric temperature provokes an upstream displacement of the frazil ice production point. If it is sufficiently warm during the day to provoke an increase in water temperature, and the nights are sufficiently cold to decrease it again, the same section of a river will produce every night a certain amount of active frazil ice. If energy losses due to friction at the foot of a rapid maintain the water temperature above  $0^{\circ}\text{C}$ , the zone of active frazil ice formation might slightly oscillate around a point situated downstream of that rapid, and a supercooling of the water lasting sometimes many days may be observed there.

### III. Frazil Transformations

When frazil ice has been formed and water temperature has come back to  $0^{\circ}\text{C}$ , only vaporous flocks of ice crystals having no tendency to grow spontaneously are left. They oscillate in the turbulent flow and those reaching the surface serve as nucleus for the regular growth of ice from heat exchanges with the atmosphere. At that stage, frazil ice does not possess any potential to grow spontaneously and we can call it inactive frazil ice.

Inactive frazil in a river evolves as shown in Fig. 4. As soon as the flocks are formed, they tend to concentrate at the surface of the flow (Williams, 1959). Their porosity is high and the total density of a flock is not much different than water's density. The turbulence of the flow brings them successively up to the surface for a while. New crystals are then formed on the side exposed to the atmosphere, without changing much their dimensions. Interstices at the interior of the flocks are closed up, they become less dense and flocks concentrate more and more at the surface. If the flow velocity is low, some stay at the surface long enough for a continuous layer of ice to form at their upper part, and finally ice floes over-topping vaporous masses of inactive frazil grow in the horizontal and vertical planes. If the flow is very fast, the flocks will become denser

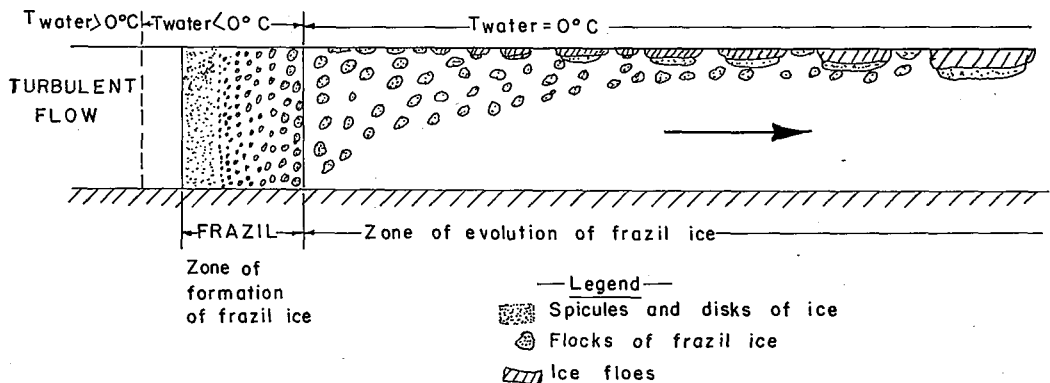
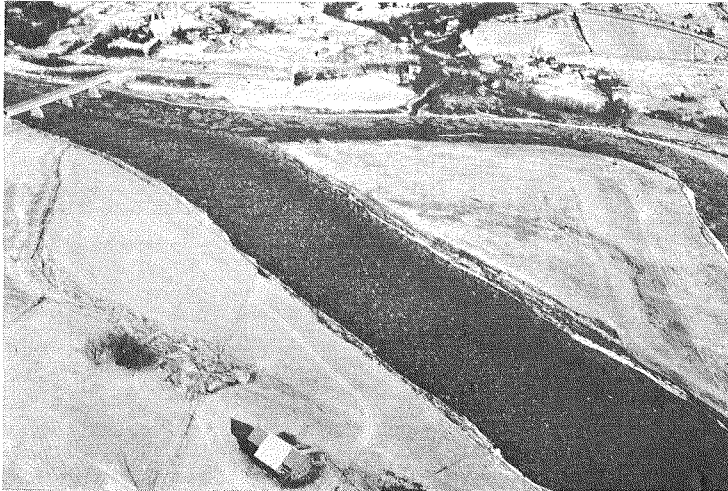

Fig. 4. Evolution of frazil ice in rivers



Frazil flocks under water

Beginning of formation of ice floes from frazil flocks



Bigger floes formed from frazil ice evolution

**Fig. 5.** Successive forms of frazil ice. Chaudière River. December 1963

and denser without forming a solid ice layer on the top. In the case of less turbulent flow, flocks will concentrate more rapidly at the surface and ice floes will be more rapidly formed. If inactive frazil can travel over long distances ice floes of great dimensions will be developed mainly by soldering of individual ice floes of pancake form. Figure 5 shows different air photographs of inactive frazil evolution.

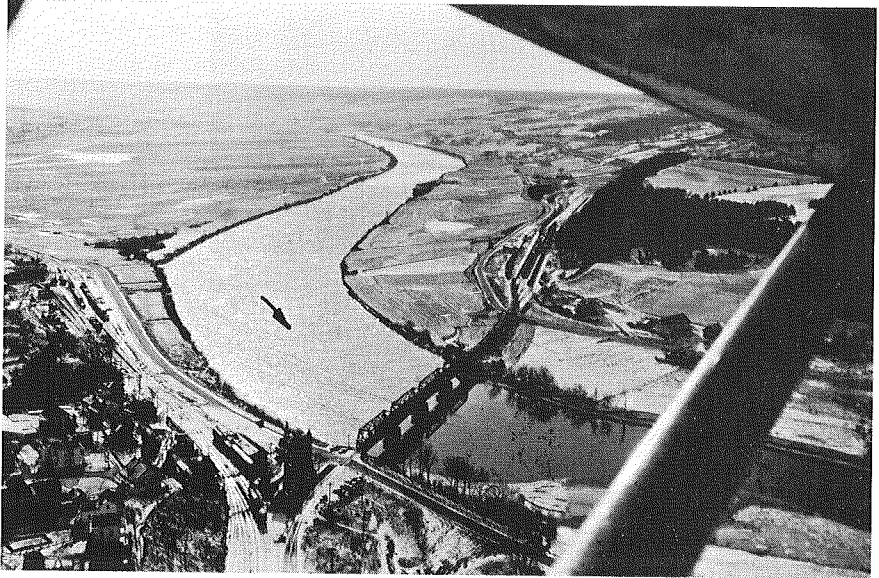

Ice cover initiated at a bridge pier

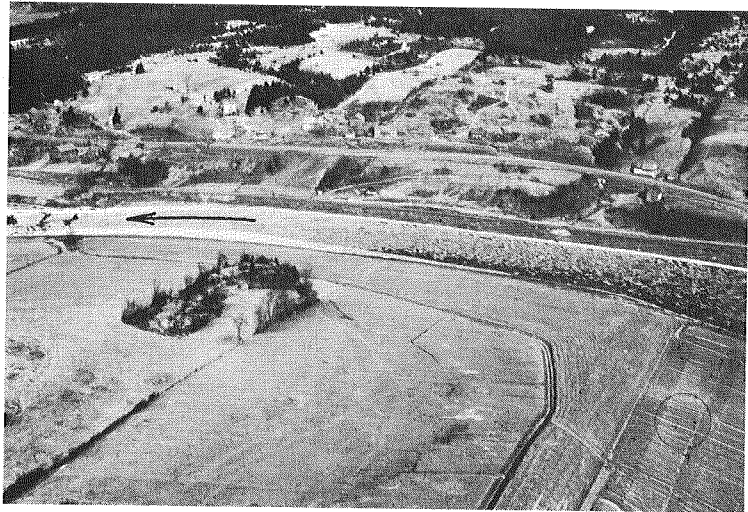

Increasing concentration of floes initiate an ice cover at a narrowing section of the river

**Fig. 6.** Beginning of an ice cover with floes coming from frazil ice evolution. Chaudière River. December 1963

#### IV. Halting and Final Metamorphosis of Frazil Ice

Because of its intermediate evolution into ice floes, frazil is essentially at the origin of ice covers in rivers. It is admitted that frazil ice is produced in turbulent flow and that those conditions are generally predominant in rivers. It has to be noted however, that ice may partially come from zones of viscous flow, at widenings of rivers or along the banks. In those zones of calm flow, an important supercooling is developed in the surface layer only before ice crystals appear. Those crystals then grow to form a solid and transparent ice sheet at the surface. Let us note also that ice in a river may also come from snow, hail or sleet falls over the river.

At the start, ice covers begin to grow from artificial obstacles which block the cross-section, or more generally by an increase in the concentration of floes at the surface which becomes such that they are stopped at a river singularity, become welded together and form an ice bridge leaning on the banks. That phenomenon is illustrated in the photographs shown in Fig. 6. This process can be considered analytically with Schoklitsch (1950) law.

Ice covers afterwards progress upstream with the oncoming of more ice floes and frazil flocks. Many theoretical and experimental approaches have been developed on the subject (Michel, 1966; Kisivild, 1959; Cousineau, 1959; St. Lawrence Waterway Project, 1926) and we do not intend to dwell on them here.

Let us only stop at the typical case represented in Fig. 7, which has not been detailed in the literature. The ice cover has normally progressed in a zone of low velocity flow and ice floes have accumulated at the foot of a rapid. Velocities becoming too high (more precisely Froude's number), the ice cover can not progress any longer.

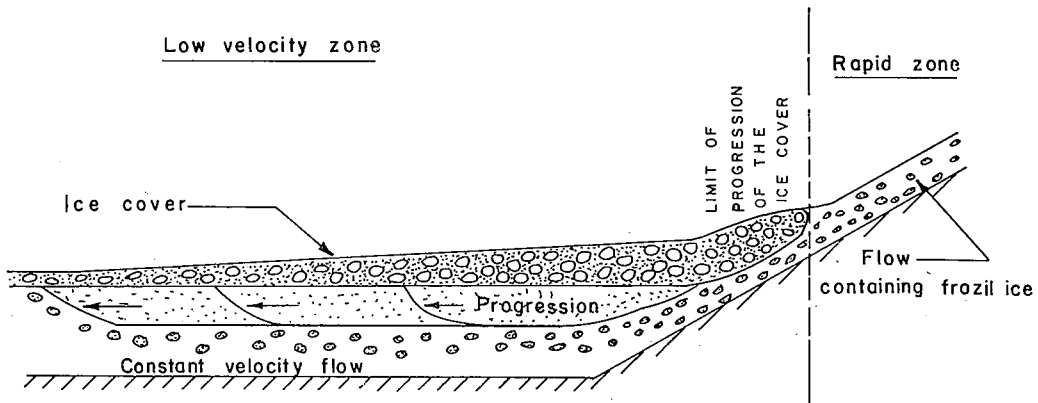

Fig. 7. Hanging dam at the foot of a rapid and progressive deposit of frazil ice downstream

That often happens when a relatively short section of flow is kept free of ice in a rapid. Sections upstream of the rapid are also ice covered. Frazil ice is then produced over a short length of river and consequently the ice cover downstream is mainly fed with inactive frazil flocks and a few small ice floes.

Since the ice cover can not progress upstream, frazil is carried downstream under

the cover until it reaches a point of sufficiently low velocity where it is deposited at the bottom part of the cover. It accumulates there and blocks part of the flow section until the velocity reaches a value high enough to carry further downstream newly arrived flocks and small floes. Thus an underhanging dam is developed occupying a considerable volume in zones of low velocity flow. Accumulations of that type have been measured during four consecutive winters (1957 to 1961) by LeGuerrier (1961) in the reservoir of the hydroelectric station "Les Marches Naturelles" in the Montmorency River. The same phenomenon has been observed at the hydroelectric station at Charny in the Chaudière River. Frazil accumulations in the reservoir of that station are shown in Fig. 8. We notice the small cross-section left for the free flowing water.

The limiting velocity for frazil ice to deposit under an ice cover depends essentially

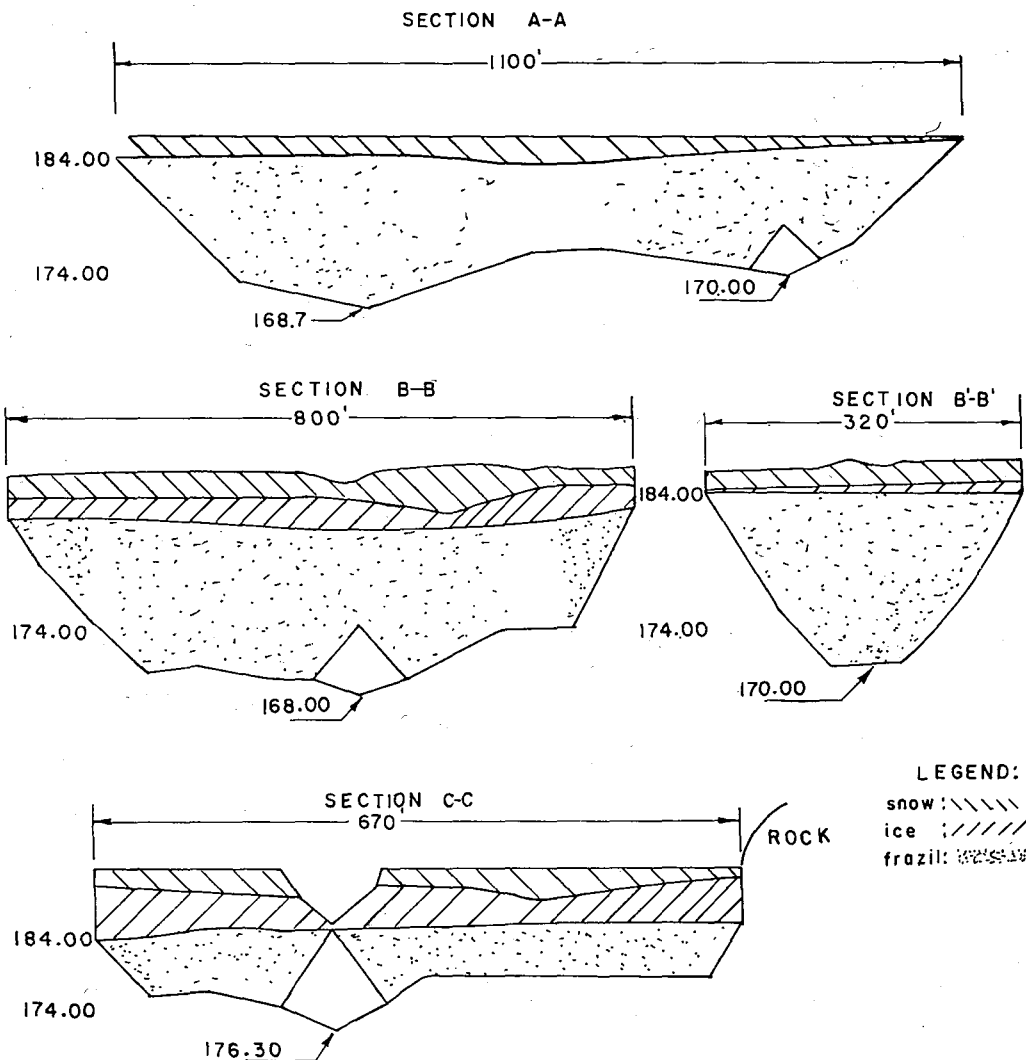

Fig. 8. Deposit of frazil ice in a reservoir, Charny-Chaudière River. Winter 1964

upon its physical aspect, that is to say upon its state of metamorphosis. It differs for very vaporous flocks, flocks with more consistency, small ice plates and ice floes. The accumulation in the reservoir at Charny contained metamorphosed flocks and thin plates of ice about 0.3 to 2 inches in diameter. The limiting velocity of frazil deposit varies from one section to the other and in spite of great inaccuracy in computation, it seems to be situated between 3 and 5 feet per second for that case.

Frazil deposited under an ice cover is unstable. As soon as the flocks are stopped,

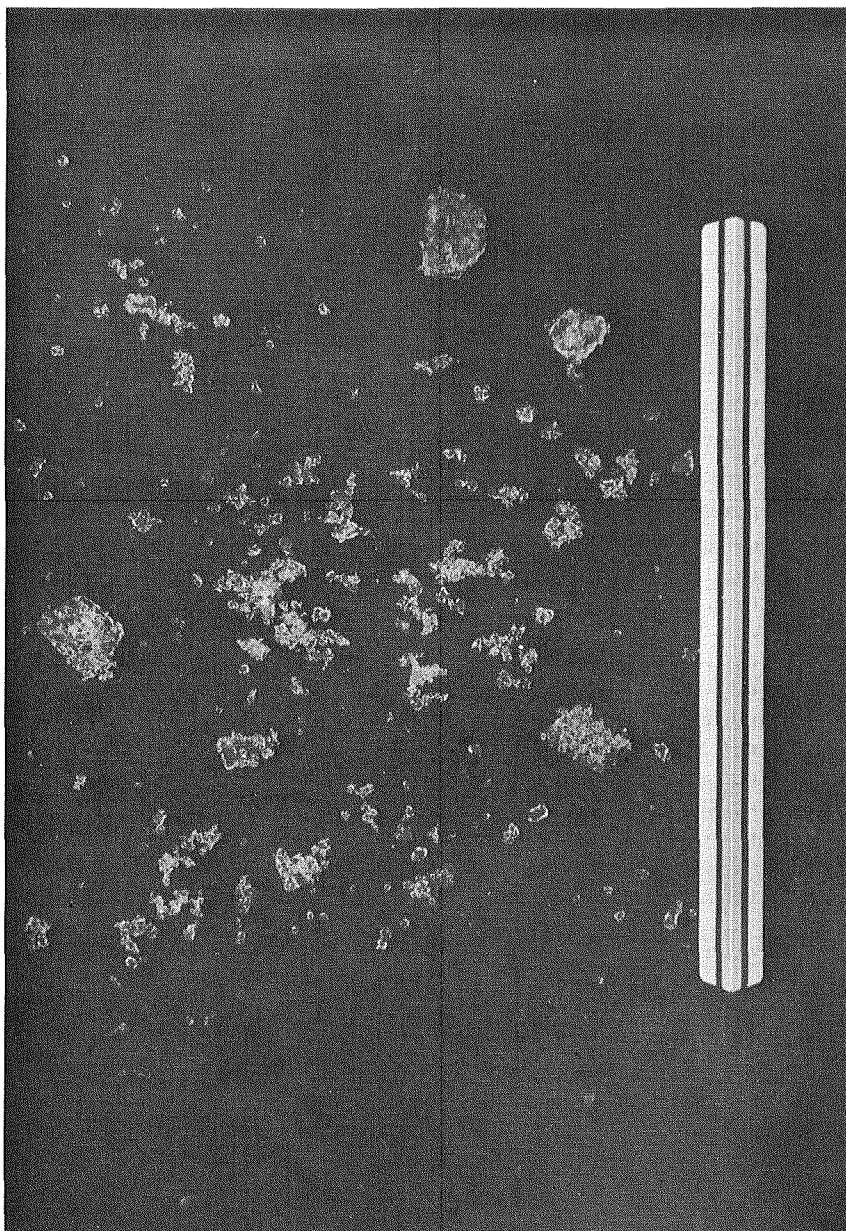

Fig. 9. Metamorphosed frazil ice in a deposit (plates, isolated and soldered ice grains)

a metamorphosis starts to operate. The small disks and spicules forming the flocks are transformed. Acute angles of the crystals disappear and new structures essentially of a much larger granular type are produced. Samples taken out at Charny show that the frazil deposited there was composed partly of small ice plates not much transformed since their arrival, and partly of particles of granular form more or less welded together, with a mean diameter of about 0.1 inch. Agglomerations of particles varied: some were composed of very fine grains well compacted and had a total diameter of about 0.25 inch, the majority consisted of less compacted groups with an approximate diameter of 0.5 inch, with grains being easily separated with the fingers. We doubt that this transformation can be explained by the well known regelation process that occurs when two ice pieces are brought together under pressure. We think that it is due to a destructive process similar to that which happens in snow covers (De Quervain, 1945). Thermodynamic instability at ice-water boundaries produces a migration of ice molecules from the angles to the convex parts, and crystals take a spherical shape and are welded together.

### V. Conclusion

We have reviewed in this article the different forms taken by frazil ice during its metamorphosis in rivers. There has always been controversy in this field of research concerning the exact forms of this type of ice and we believe that the observations we have made in nature will help to clarify the fact that frazil ice is always changing in an evolutive process.

These observations were made possible with research funds of National Research Council of Canada and the collaboration of a field team of the Department of National Resources, Province of Quebec.

### References

- 1) ALTBURG, W. J. 1936 Anchor ice. *Intern. Assoc. Sci. Hydrol., Bull.* No. 23, 373-407.
- 2) COUSINEAU, J. E. 1959 Some aspects of ice problems. *Engng. J.*, 42, No. 3, 50-54.
- 3) DE QUERVAIN, M. R. 1945 Snow as a crystalline aggregate. *Experientia*, 1, 207-214.
- 4) KIVISILD, H. R. 1959 Hanging ice dams. Proceedings 8th Congress AIRH, Seminar No. 1. 1-SI-1 — 1-SI-3
- 5) LEGUERRIER, V. 1961 Report on Frazil ice-Montmorency River, Quebec Power Co., 30 pp.
- 6) MICHEL, B. 1963 Theory of formation and deposit of frazil ice. Proc., 20th meeting-Eastern Snow Conference, 130-148.
- 7) MICHEL, B. 1964 Elements de la Physique de la Glace et de la Neige. Les Presses de l'Université Laval, 85 pp.
- 8) MICHEL, B. 1966 Analyse d'hypothèses relatives à la progression des champs de glace. *L'Ingénieur*, 52, No. 209, 41-45.
- 9) SCHOKLITSCH, A. 1950 Handbuch des Wasserbaues., Springer-Verlag, Wien, 474 pp.
- 10) St. Lawrence Waterway Project 1926 Ice formation in the St. Lawrence and other Rivers. Report of the joint Board of Engineers, Appendix "E", 406-423.
- 11) WILLIAMS, G. P. 1959 Frazil ice. *Engng. J.*, 42, No. 11, 55-60.
- 12) YOUNG, S. W. 1910 Mechanical stimulus to crystallization in supercooled liquids *J. Amer. Chem. Soc.*, 33, 148-162.