



HOKKAIDO UNIVERSITY

Title	Frictional Electrification of Ice and Change in Its Contact Surface
Author(s)	MAGONO, Choji; 孫野, 長治; SHIO, Hisashi et al.
Description	International Conference on Low Temperature Science. I. Conference on Physics of Snow and Ice, II. Conference on Cryobiology. (August, 14-19, 1966, Sapporo, Japan)
Citation	Physics of Snow and Ice : proceedings, 1(1), 137-150
Issue Date	1967
Doc URL	https://hdl.handle.net/2115/20292
Type	departmental bulletin paper
File Information	1_p137-150.pdf



Frictional Electrification of Ice and Change in Its Contact Surface

Choji MAGONO and Hisashi SHIO

孫野長治 志尾 弥

Faculty of Science, Hokkaido University, Sapporo, Japan

Abstract

It is known that when two ice rods are rubbed asymmetrically, the ice rod with the constant rubbing point is electrified negatively, and the other ice rod with the variable rubbing point is electrified positively. It is considered that this frictional electrification is caused by the temperature difference in the two rubbing points on the ice rods. (The constant rubbing point becomes warmer than the variable rubbing point.)

Experiments of such frictional electrification of ice rods were carried out at various room temperatures below freezing, and the changes in fine structure of the rubbed ice surface were observed under a polarizing microscope. As a result, the following facts were found:

1. At temperatures colder than -10°C , the warmer ice was electrified negatively as it was generally found hitherto, but when the rubbing was continued, the sign of electrification changed to the opposite.

2. At temperatures warmer than -5°C , the warmer ice was electrified positively from the beginning of the rubbing experiment, which is quite different from the results obtained hitherto.

3. When the sign of electrification became the opposite of results hitherto, the area of rubbed surface of the warmer ice showed numerous fine polygonal patterns which indicate that the structure of the rubbed surface changed from single crystal to a polycrystalline.

I. Introduction

Yosida (1944) reported that when two pieces of ice of different temperature were rubbed together, the colder ice was electrified positively. The same result was found independently by Reynolds, Brook and Gourley (1957) and was reconfirmed by Latham (1963). Latham and Mason (1961) attempted to explain these results theoretically by the use of concentration gradient of H^+ and OH^- in a steady temperature gradient in ice. According to their theories, H^+ ions are assumed to concentrate in the colder part of the ice.

Recently however, it was noted that the charge separation in ice could not always be explained by this theory, but was influenced by other factors, even when the ice was produced from pure water; for example as pointed out by Takahashi (1962), Evans and Hutchinson (1963), and Magono and Shiotsuki (1964). The most difficult point in the theory is that in a temperature region warmer than -10°C , the sign of charge separation in ice is opposite to that of the charge separation which may be expected from the theory, as reported by Magono and Takahashi (1963 a, 1963 b).

This problem is important, because the main charge separation in thunderclouds is considered to be related to the friction or impact between ice particles around -10°C altitude in thunderclouds. Therefore, a more detailed study on the frictional electrification

of ice in the vicinity of -10°C will be required for the full understanding of the mechanism of charge separation in thunderclouds. This paper will describe the results of an experiment made for this purpose. The experiment was made at temperatures below and above -10°C with special reference to the change of fine structure of ice surface due to friction.

II. Measuring Method

Preparation of ice specimens. The experimental data for frictional electrification of ice made hitherto, were widely scattered. This may possibly because the effect of unknown factors, namely, fine structure of ice surface, impurity and other properties of ice. Therefore, the following steps were taken for the preparation of ice specimens in the present experiment.

a. A pair of ice specimens of cylindrical shape were produced from the same distilled water, in order to ensure even quality. The ice specimens were transparent and had no air-bubbles or cracking. The size of the cylindrical specimens was 3 cm in diameter and approximately 12 cm in length. The ice specimen was suspended by a metallic rod which penetrated the axis of the cylindrical specimen, as shown schematically in Fig. 1.

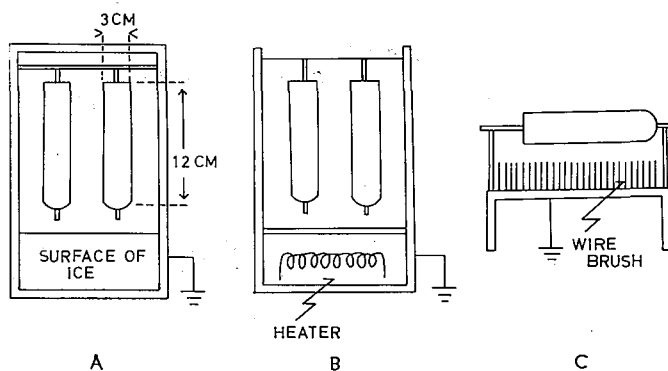

Fig. 1.

b. Because it was desirable to use the same pair of ice specimens repeatedly under various temperature conditions, after an experiment the specimens were stored in a box in which the air was saturated, as shown in Fig. 1 A.

c. In order to renew the used rubbing ice surface in the previous experiment, prior to the next experiment the pair of specimens were heated slightly to melt and to wash out the used surface as shown in Fig. 1 B, after which they were refrozen. This treatment gave a completely renewed surface of ice.

d. It was desirable to remove a charge completely from ice specimens in prior to the measurement, but it was difficult owing to unknown factors, although the specimens were grounded. In an attempt to remove this otherwise unremovable charge, one of the ice specimens of a pair was set close to a wire brush for about 3 hours, and kept under an insulated condition, as shown in Fig. 1 C. This treatment was successful.

e. Measurement was started within 4 hours after the preparation of renewed ice

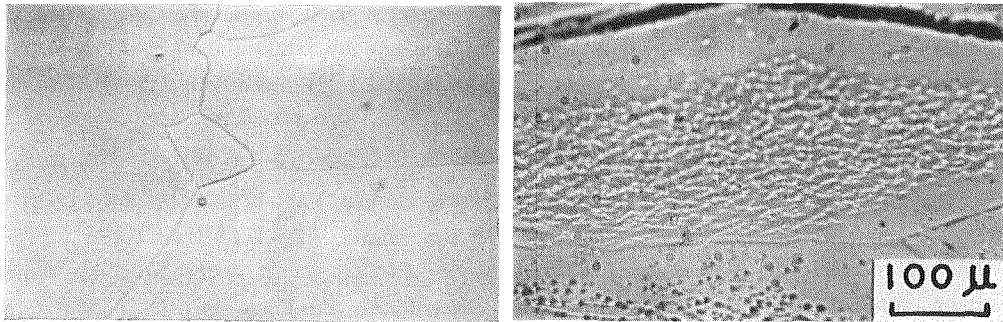

After 4 hrs
 After 24 hrs
Fig. 2. Natural change in surface of ice due to evaporation

specimens, because if such specimens are left for a long time, microscopical changes occur on the surface of ice, as seen in Fig. 2.

The above preparations for ice specimens, resulted in good reproducibility as will be described later.

Rubbing treatment. The measurements were made in a metallic shielding box in a cold chamber at the Institute of Low Temperature Science. The friction between ice specimens of different temperatures was made by the so called asymmetric rubbing of two ice specimens of even quality, as shown schematically in Fig. 3.

One of the ice specimens of a pair was mounted perpendicularly on the other specimen which was fixed and connected to a quadrant electrometer. The former specimen was movable but was always grounded. When the movable specimen is shifted from side to side as shown in the upper picture of Fig. 3, its contact point is considered to become warmer than that of the fixed specimen because of frictional heat, in as much as the contact point of the moving specimen is kept constant, while the contact point of the fixed specimen changes during rubbing. In this case, the fixed specimen with a changing contact point will be called 'colder ice' and the other moving specimen with a constant contact point will be referred to as 'warmer ice' in this paper.

In the case of rubbing combination as shown in the lower pictures of Fig. 3, the fixed specimen with a constant contact point was 'warmer ice', and the moving specimen with a changing contact point was 'colder ice'.

The actual weight of the upper movable specimen on the contact point of the lower fixed specimen was approximately 90 g. However, this weight decreased to about 70 g at the final measurement, because the specimen was used repeatedly and melted to renew the surface.

Naturally pure ice in neither a conductor

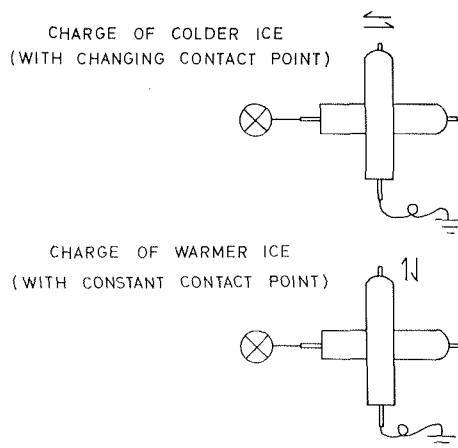

Fig. 3. Asymmetric rubbing of ice against ice

nor a perfect insulator. Accordingly the electrometer used in the present experiment was expected to detect the excess of generating charge by friction over leaking charge through ice from the system of the moving specimen which was grounded.

III. Results

Measurements were made in three temperature ranges, namely in cold range ($-21\sim-10^{\circ}\text{C}$), in middle range ($-8\sim-5^{\circ}\text{C}$) and in warm range ($-3\sim-1.5^{\circ}\text{C}$).

Frictional electrification in cold range ($-21\sim-10^{\circ}\text{C}$). In order to run a comparison against results obtained hitherto, an experiment was made at first in cold temperatures below -10°C . Figure 4 shows the results obtained at -16°C . The left picture of the figure shows the time change of charge generated on 'colder ice' with changing contact points. At first, a positive charge was generated on the colder ice as expected from the theory and increased as the shifting continued, then its value reached a maximum value at 20 sec after the start of shifting. The stage from the start to the maximum value will be referred to as the 'first stage'. Then, in contrast, the positive charge began to decrease and surprisingly changed to negative at 25 sec from the start, and then approached a saturated value of -0.5 e.s.u. which kept nearly steady for the further shifting. The stage after the maximum value will be referred to as the 'second stage'.

As described above, the generation of positive charge on the colder ice in the '1st stage' was the same as expected from the established theory. The rate of the positive charge generation was roughly 0.2 e.s.u. $\cdot\text{sec}^{-1}$. However, the rapid change of charge in the '2nd stage' showed that a considerable negative charge with a magnitude of approximately -1.0 e.s.u. was accumulated on the colder ice. This was quite different from the theory. The generating rate of the negative charge on the colder ice in the 2nd stage was computed roughly as -0.1 e.s.u. $\cdot\text{sec}^{-1}$.

In order to verify this, the experiment was repeated under a reverse condition with

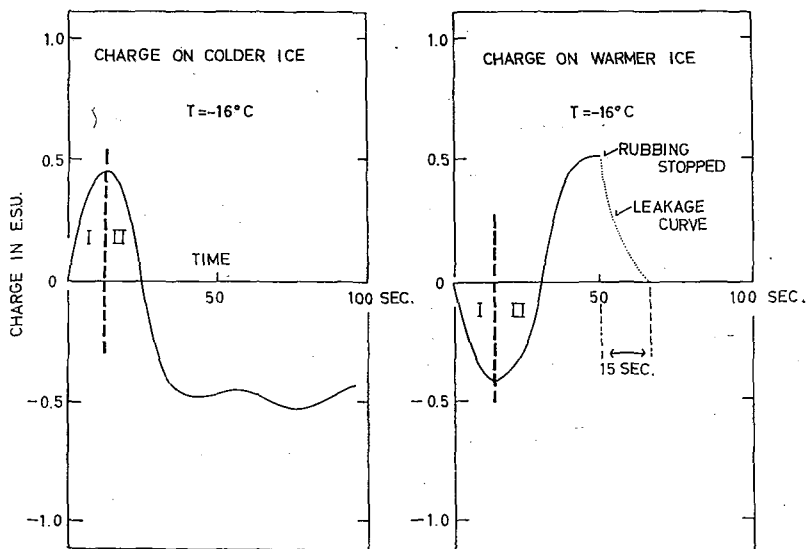

Fig. 4. Occurrence of 2nd stage

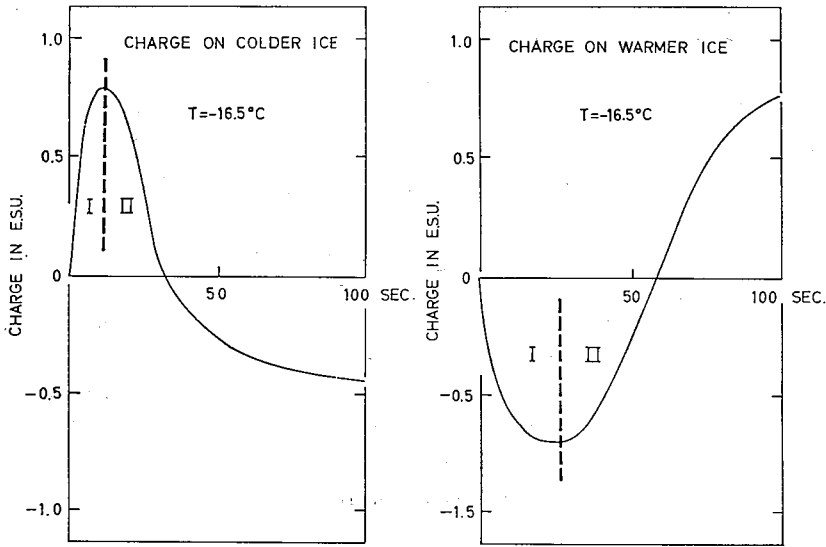

Fig. 5. Occurrence of 2nd stage

respect to temperature difference, namely, under the condition given in the lower picture of Fig. 3. The result obtained is shown in Fig. 4. It was quite the same electrically as the results described in the previous paragraph. In other words, the warmer ice obtained a negative charge in the 1st stage, then in the 2nd stage it obtained a positive charge of a magnitude greater than the negative charge in the 1st stage. The broken line at 50 sec in the right picture of Fig. 4 shows the leakage curve of this measurement system, from which the half value period of leakage was computed to be approximately 5 sec. Another result of a similar experiment carried out at -16.5°C is shown in Fig. 5. Such experiments were repeated 80 times, and the results were identical electrically without exception.

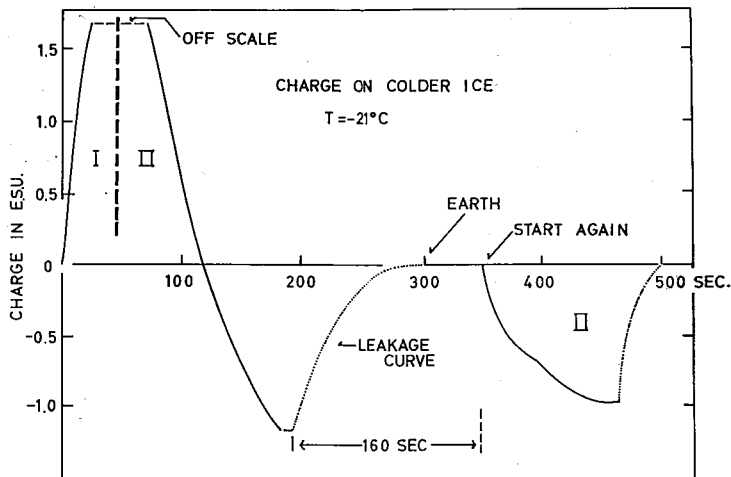

Fig. 6. Occurrence of 2nd stage

The occurrence of the 2nd stage suggests that some change occurred at the rubbing points by continued friction in the later half period of the 1st stage. In order to gain some knowledge concerning this change, the following experiment was made at -21°C as shown in Fig. 6. As seen in the figure, both the magnitude of positive charge on the colder ice in the 1st stage and that of the negative charge in the 2nd stage were considerably greater than in the case of Figs. 4 and 5. This was perhaps because of decreased leakage due to colder temperature. At 200 sec in Fig. 6, the rubbing treatment was stopped, while other conditions were kept as they were. Then the negative charge began to leak and tended towards zero. At 350 sec (160 sec after the stopping of rubbing) rubbing was started again at the same contact point. The time of 160 sec was sufficiently long to allow the refreezing of melted water even when part of the ice at contact points was partially melted due to frictional heat. It was noted that a negative charge was generated from the first, in other words, the 2nd stage occurred without the 1st stage. This phenomenon in which the recommenced rubbing did not produce the 1st stage, was confirmed by repeating such experiments under reverse conditions with respect to temperature difference as shown in Fig. 7. The result thus confirmed, showed that some change occurred at contact points by rubbing at the end of the 1st stage, and the change was fairly steady. However, it is not yet known whether the change of contact point occurred on the colder ice or on the warmer ice.

In order to determine this, the following experiment was made in a 'cold range'. As seen in Fig. 8, 1st and 2nd stage occurred in the same manner as in the case of Figs. 4, 5, 6 and 7. The rubbing treatment was once stopped at 160 sec when the negative charge in the 2nd stage reached a saturated value, then the negative charge began to leak and tended towards zero value. Then the rubbing contact point of the moving specimen (warmer ice) was replaced by rotating the moving specimen around its axis. The rubbing point of the fixed specimen (colder ice) was kept as it was. The rubbing treatment was started again under this condition at 225 sec. In this case, as seen in the right hand picture of Fig. 8, 1st stage (positive charge on colder ice) occurred from the first, in the same manner as in the former rubbing. This result indicates that the replacement of the contact point of the warmer ice was not effective on the change in contact points. Similar experiments were made as shown in Fig. 9, however in this case the contact point of the colder ice was replaced and the warmer ice was kept as it was. It was noted in this case that the 2nd stage (negative charge on colder ice) occurred from the first without the 1st stage in the second rubbing treatment as seen in the right hand picture of Fig. 9. The results of the former and of the later experiments show that the effective change in contact rubbing points occurred on the side of the warmer ice.

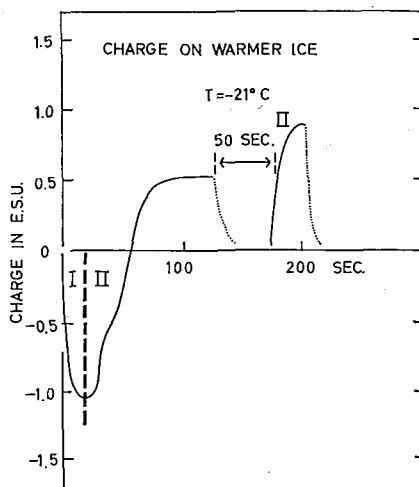

Fig. 7. Occurrence of 2nd stage

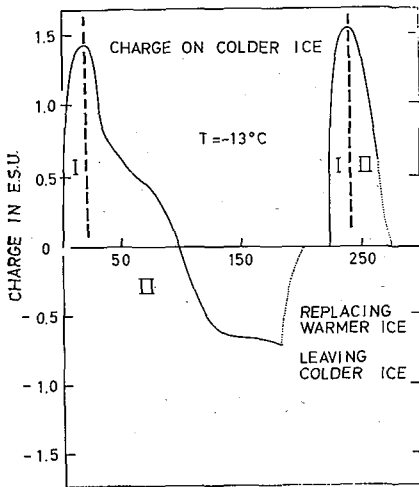

Fig. 8. Effect of replacement of warmer contact point

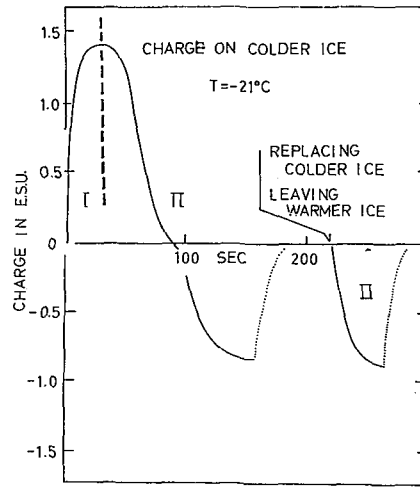

Fig. 9. Effect of replacement of colder contact point

Change in fine structure of rubbed surface (contact point) of ice due to rubbing. In order to study for the mechanism of occurrence of the 2nd stage, the contact surface of the ice changing with the rubbing was observed under a microscope. Figure 10 shows the process of change in fine structure of rubbed surfaces (contact point). Before rubbing, the ice specimen had a uniform and simple surface as seen in the photograph at the top of the figure. The left hand and right hand series of photographs show the process of change of colder and warmer ice respectively. The time lapse from the start is shown in each photograph. By rubbing, the colder ice took on a pattern of uniform fine streaks which were parallel to the shifting direction, and the pattern was fairly steady during rubbing; however at about 50 sec, a few boil-like spots began to appear, as seen in the left hand series. While the pattern of contact surface of the warmer ice was highly irregular from the first, thereafter it changed to an assemblage of cells, as seen in the right hand series of Fig. 10. The size of such cells was approximately $20\ \mu$ in average at first, and thereafter they increased to $50\ \mu$ as the rubbing was continued.

Next, the change of contact surface, in parallel with the generation of charge on ice specimens was observed. Figures 11 and 12 show the result of experiments which were made for this purpose. The respective time of each photograph is indicated by A, B, C and D. In the case of the colder ice, it may be seen in Fig. 11 that a pattern of uniformly scratched streaks on the colder ice was kept fairly steady until the 2nd stage, but that a few boil-like spots appeared in the 2nd stage. These spots are considered to be fragments of ice which were scraped from the warmer ice, because the warmer ice was softer than the colder ice. The ratio of the area occupied by these spots was small.

On the other hand in the case of the warmer ice, as seen in Fig. 12, the scratched pattern on the rubbed surface was highly irregular from the first in the 1st stage, and the irregular pattern changed to an assemblage of polygonal cells in the 2nd stage. Such a surface which was destroyed to cellular pattern was limited to only the contact surface of ice. It did not penetrate into the inner part of the ice.

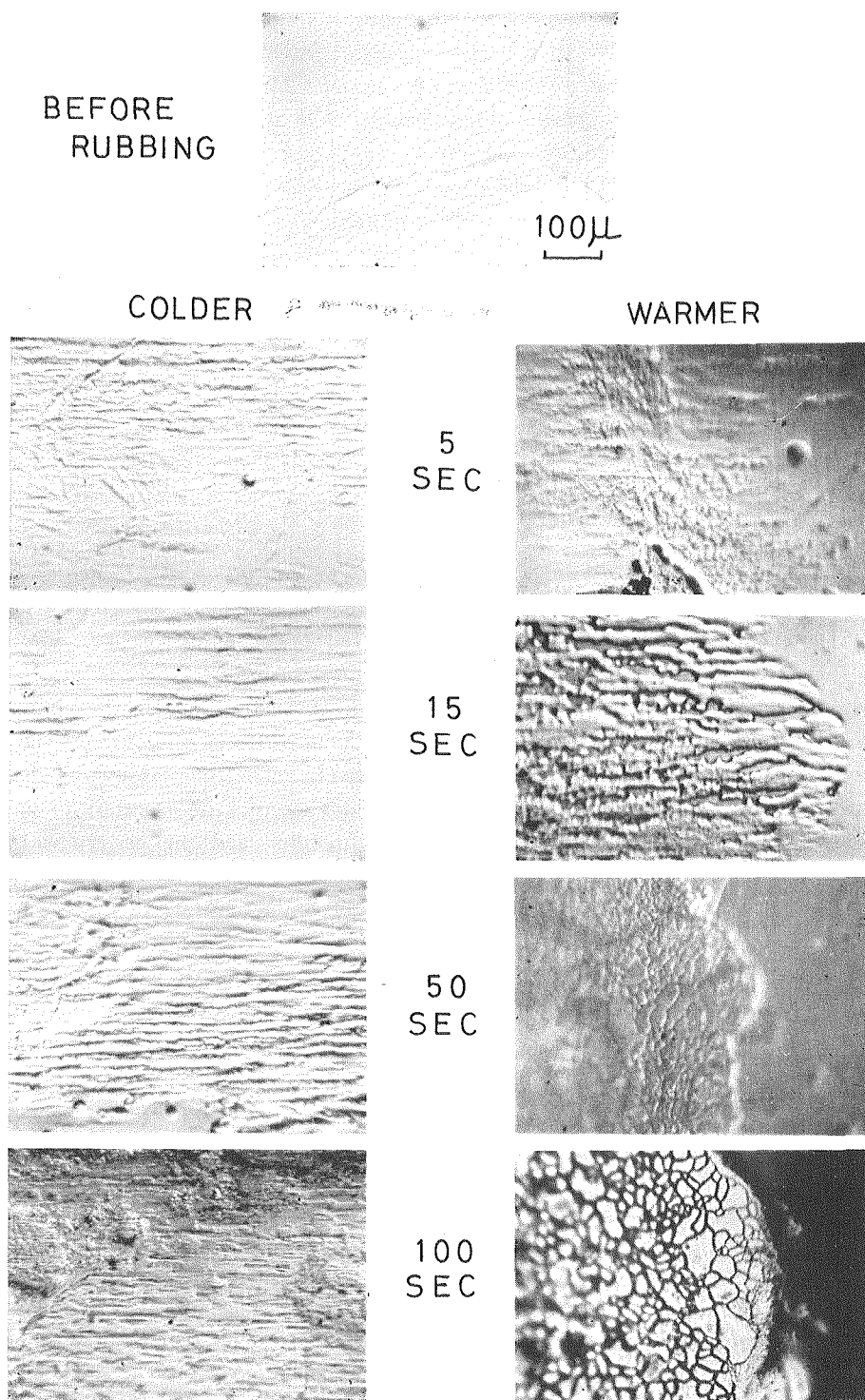

Fig. 10. Change of contact surface due to rubbing ($T = -16^{\circ}\text{C}$)

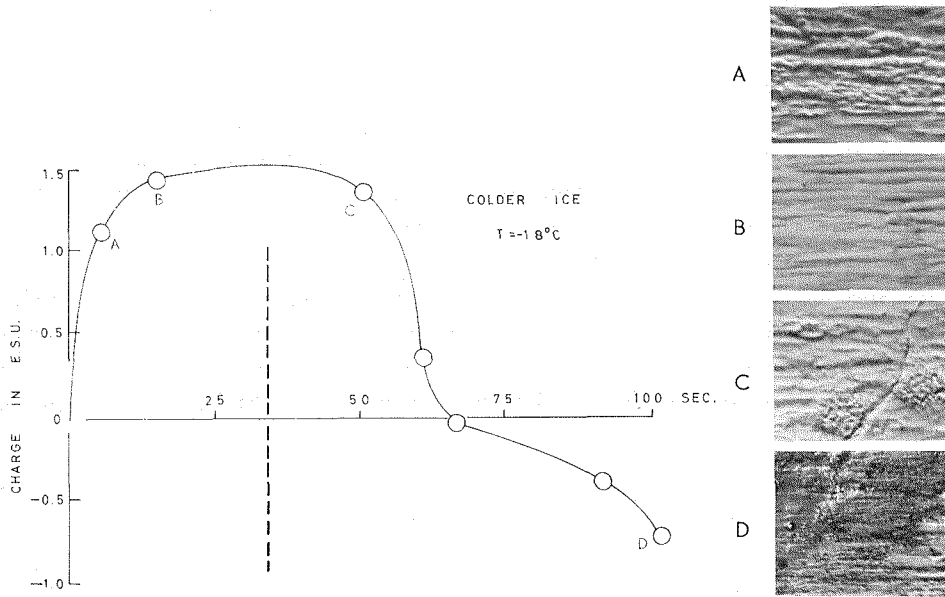

Fig. 11. Change of contact surface of colder ice

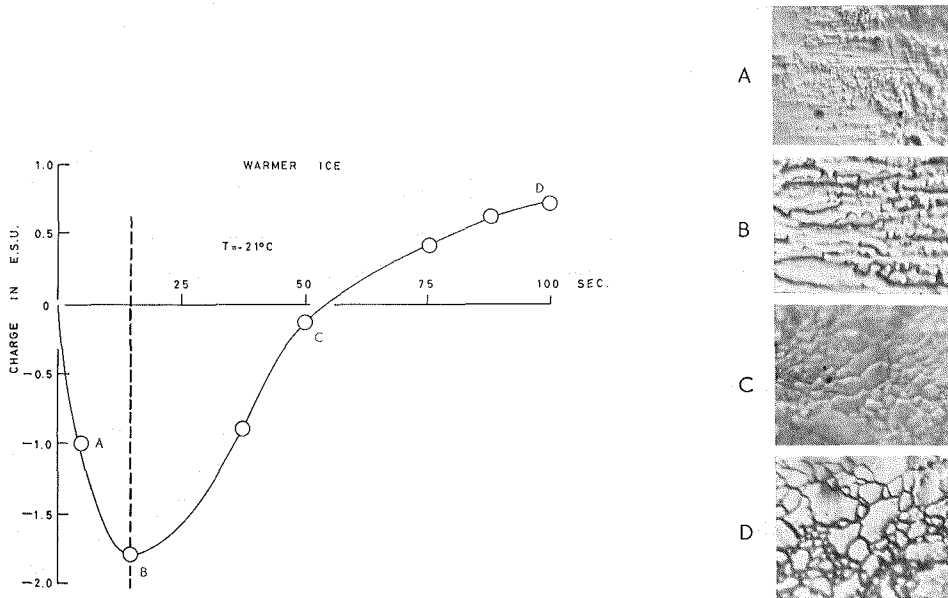

Fig. 12. Change of contact surface of warmer ice

As described already, because the change of contact point of the warmer ice was effective on the occurrence of the 2nd stage, and because the time of appearance of the 2nd stage of the cellular pattern in the warmer contact point, roughly coincided to the time of occurrence of the 2nd stage, it was considered that the occurrence of such cellular pattern was an important factor for the occurrence of the 2nd stage.

Under a polarization microscope, it was observed that a part of the cellular pattern produced by rubbing was changed to minute polycrystallines, and that as rubbing was

continued, the size of the cells increased from $20\ \mu$ to $50\ \mu$, while the size of individual blocks of polycrystalline decreased from $500\ \mu$ to $50\ \mu$. It was in the later steady state of the 2nd stage that the size of polycrystallines agreed with that of cells. The time of occurrence of the 2nd stage coincided with the appearance of cellular pattern rather than with that of polycrystalline. Accordingly it is considered that the occurrence of boundaries of such cells is important for the occurrence of the 2nd stage. The cell boundaries are assumed to be produced by the repetition of melting and refreezing of thin water film which was melted by frictional heat.

Ice specimens were made of polycrystallines already when they were prepared, but as far as the rubbing phenomenon was concerned they are considered to be made of single crystal ice, because the size of original polycrystallines was two orders greater than the area of contact surface, and they were quite different from the minute polycrystallines which were produced by rubbing.

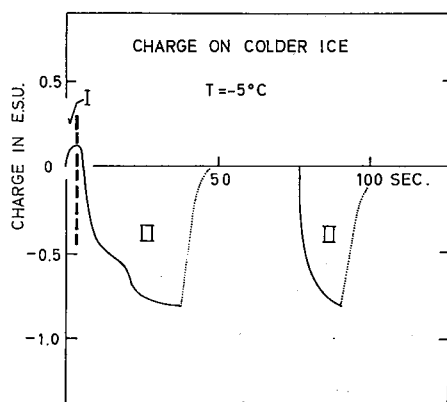

Fig. 13. Electrification in middle range

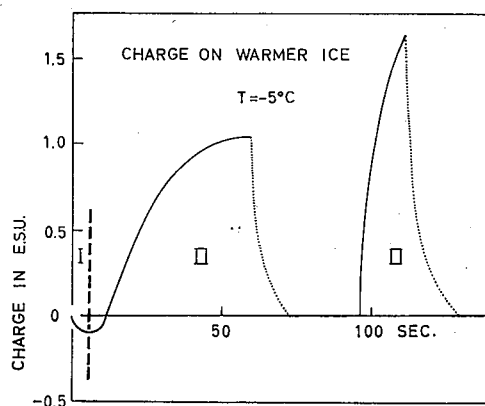

Fig. 14. Electrification in middle range

Frictional electrification in the middle range ($-8\sim-5^{\circ}\text{C}$). From the experimental result concerning the electrification of riming by Magono and Takahashi (1963 b), it was conjectured that -10°C is a transitional temperature for the charge separation of ice, although the transitional temperature depended on the rate of riming. Therefore in the present experiment, the temperature range slightly warmer than -10°C , namely -8 to -5°C was adopted. Examples of the result are shown in Figs. 13 and 14. It may be seen in the figure that in this temperature range, the 2nd stage always occurred clearly, but the occurrence of the 1st stage was very irregular. Sometimes the 1st stage was not even observed. Even if the 1st stage occurred, it was slight and disappeared in a short time, namely in 5 to 10 sec, as seen near the starting time of rubbing in Figs. 13 and 14. When the rubbing treatment was started again, the 2nd stages always occurred from the first without the occurrence of the 1st stage. These results indicate that the change of contact point occurs more rapidly in the middle temperature range than in the cold range. And in practice, the irregular cells were always observed a little after the start of rubbing. This tendency will be understood more clearly by the experiment in the warm range below.

Frictional electrification in the warm temperature region ($-3\sim-1.5^{\circ}\text{C}$). In order

to confirm the tendency described above, similar experiments were repeated just near the melting point of ice, namely at a range of -3 to -1.5°C . As illustrated in Figs. 15 and 16, no 1st stage was observed in the warm range. Because the rate of leakage was high and the indicator of the electrometer vibrated violently in such warm temperature, exact measurements were difficult. However, it was confirmed that the 1st stage did not occur and rubbing.

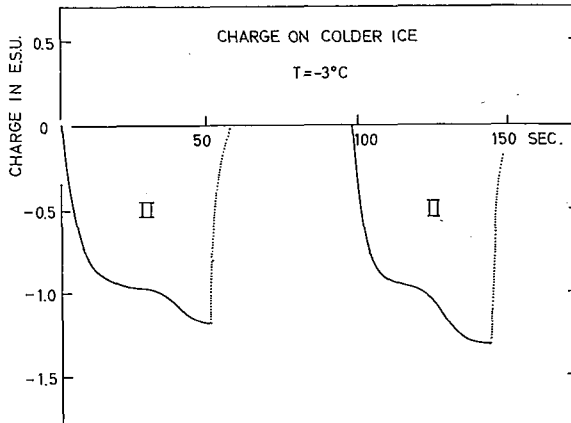

Fig. 15. Electrification in warm range

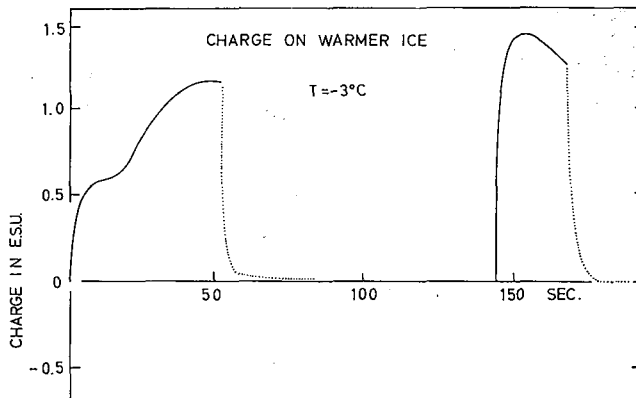

Fig. 16. Electrification in warm range

Friction between opaque ice and transparent ice. Because it was confirmed that the change of contact surface to irregular cell pattern was important for the occurrence of the 2nd stage, the frictional experiments were repeated using ice specimens which were prepared particularly for this purpose as described below. Milky opaque ice specimens were obtained by freezing a mixture of nonpolluted natural snow particles and water of a near freezing temperature. The water was melted beforehand from natural snow particles. The milky opaque specimens contained numerous air-bubbles and cracks in addition to cells of polycrystalline, and the size of cells were one order greater than that of the cells produced by rubbing. Therefore it was considered that the friction

experiment using such opaque ice did not exactly represent the frictional electrification of changed surface by rubbing; however as far as the effect of cell boundary is concerned such an experiment will be useful. Against such opaque ice specimens, the usual ice specimen is called 'transparent ice' in this paper.

By the addition of the factor: opaque to transparent, we have the following two combinations for friction, namely 'colder opaque to warmer transparent', and 'colder transparent to warmer opaque'. The result of experiments with such combinations showed that in any combination, the opaque ice was charged positively regardless of temperature differences. It is noted that this result agreed with that of the previous experiment which was reported by Magono and Shiotsuki (1964), although they centered their attention on the effect of air-bubbles in ice.

IV. Considerations

Because the results obtained were influenced by many factors and were complex, they are summarized in the following table for convenience sake.

The theory established hitherto says that colder ice will be electrified positively by friction against warmer ice. However, as may be seen in the table given below, the theory merely explains the frictional electrification in the 1st stage. In other cases, the effect of change in surface by friction overcomes the effect of temperature difference.

Signs of charge on ice specimens

Specimen Stage Temperature	Colder		Warmer		Uniform streak pattern	Destroyed cell pattern
	1st stage	2nd stage	1st stage	2nd stage	2nd stage	2nd stage
-21~-10°C	+	-	-	+		
- 8~- 5°C	+	-	-	+	-	+
- 3~-1.5°C		-		+		

The frictional electrification of ice is by nature a very complex phenomenon, being influenced by many factors, although the effect of impurity is removed. Therefore considerations were made for the most important factors, namely temperature, liquid-like film and fine structure of ice surface.

Temperature and temperature difference. Latham and Mason (1961) considered that the charge is transported by H^+ to the colder part of ice in a steady temperature gradient. This theory is applicable only to the frictional charge in the 1st stage in temperatures colder than -10°C . Against this theory, Takahashi (1966) presented an idea that in temperatures warmer than -10°C , L-defect is the charge carrier, whereupon the positive charge is generated in the warmer part of ice. His idea is useful for the explanation of frictional charge in the warmer temperature region, however it can not explain the change in sign of charge in the 2nd stage.

Liquid-like film on ice surface. It was pointed out by Nakaya and Matsumoto (1954)

that liquid-like film exists on the surface of ice. It may reasonably be presumed that the warmer the ice, the more prominent the liquid-like film. It is therefore considered that in the warmer region the friction phenomenon will occur as a surface phenomenon in solid-liquid-solid, rather than solid-solid state. If this is the case, no theory based on the surface phenomena in solid-solid state is applicable to such frictional electrification. Because no theory has been established for the friction of such solid-liquid-solid state of ice, it is impossible to make further considerations, however, there is a possibility that the electrification by friction between solid-liquid-solid is the opposite of that of solid-solid state.

Change in contact surface due to rubbing. It was confirmed that the sign of frictional electrification was mainly determined by the change in contact point from a uniform surface to a surface of irregular cell boundaries (subgrain boundaries), except in the case of early stages in a cold temperature range lower than approximately -10°C . If such changes occurred in the colder temperature range initially, the 1st stage could not possibly occur while the 2nd stage would occur from the first. If this is the case, the temperature itself merely plays a role in the determination of the grade of easiness of occurrence of the 2nd stage.

As the charge carrier in ice, H^+ ions, OH^- ions, dislocations and defects, may be considered for example. The irregular cells produced at the contact point has many cell boundaries, the electric conductivity of which is much greater than that of the uniform single crystal ice. Therefore in the difference of concentration of the boundaries, for example a transparent uniform single crystal ice in contact with an opaque ice, the charge carrier may be presumed to be quite different from that of the case of temperature difference. And in practice, the result of the experiment for frictional experiment of ice showed that the charge carrier in the difference of cell boundaries concentration is opposite to and greater than that of temperature difference.

V. Conclusion

As a result of frictional experiments with ice in a wide and varying temperature condition, the following conclusions were obtained:

1. The temperature gradient theory proposed by Latham and Mason holds only in the case of the early stage at a temperature range colder than approximately -10°C .
2. In the other cases, the frictional surface of the warmer ice changed rapidly and the warmer ice was always charged positively. This electrification is opposite to the theory in sign of charge.
3. In the existence of difference of the concentration of cell boundaries, the sign of charge carrier seems to be opposite to and stronger than that of the temperature difference.

Acknowledgments

The authors wish express their thanks to Dr. Z. Yosida, the director of the Institute of Low Temperature Science, Hokkaido University, who permitted the use of one of the Institute's cold chambers.

References

- 1) EVANS, D. G. and HUTCHINSON, W. C. A. 1963 The electrification of freezing water droplets and colliding ice particles. *Quart. J. Roy. Meteorol. Soc.*, **89**, 370-375.
- 2) LATHAM, J. 1963 Electrification produced by the asymmetric rubbing of ice on ice. *Brit. J. Appl. Phys.*, **14**, 488-490.
- 3) LATHAM, J. and MASON, B. J. 1961 Electric charge transfer associated with temperature gradient in ice. *Proc. Roy. Soc.*, **A 260**, 523-536.
- 4) MAGONO, C. and SHIOTSUKI, Y. 1964 On the effect of air-bubbles in ice on frictional charge separation. *J. Atmos. Sci.*, **21**, 666-670.
- 5) MAGONO, C. and TAKAHASHI, T. 1963 a On the electrical phenomena during riming and glazing in natural supercooled cloud droplets. *J. Meteorol. Soc. Japan, Ser. II*, **41**, 71-81.
- 6) MAGONO, C. and TAKAHASHI, T. 1963 b Experimental studies on the mechanism of electrification of graupel pellets. *J. Meteorol. Soc. Japan, Ser. II*, **41**, 197-210.
- 7) NAKAYA, U. 1954 *Snow Crystals, Natural and Artificial*, Harvard Univ. Press, 301 pp.
- 8) REYNOLDS, S. E., BROOK, M. and GOURLEY, M. F. 1957 Thunderstorm charge separation. *J. Meteorol. Amer.*, **14**, 426-435.
- 9) TAKAHASHI, T. 1962 Electric charge generation by breaking of ice pieces. *J. Meteorol. Soc. Japan, Ser. II*, **40**, 277-286.
- 10) TAKAHASHI, T. 1966 Thermoelectric effect in ice. *J. Atmos. Sci.*, **23**, 74-77.
- 11) YOSIDA, Z. 1944 The mechanism of charge generation in friction and destruction of ice and in thunderclouds. *Low Temp. Sci.*, **1**, 149-187. (In Japanese with English summary).