



HOKKAIDO UNIVERSITY

Title	On Theory of the Flow of Glaciers
Author(s)	Vyalov, S.S.
Description	International Conference on Low Temperature Science. I. Conference on Physics of Snow and Ice, II. Conference on Cryobiology. (August, 14-19, 1966, Sapporo, Japan)
Citation	Physics of Snow and Ice : proceedings, 1(1), 349-356
Issue Date	1967
Doc URL	https://hdl.handle.net/2115/20308
Type	departmental bulletin paper
File Information	1_p349-356.pdf



On Theory of the Flow of Glaciers*

S. S. VYALOV

C. C. ВЯЛОВ

Research Institute of Bases and Underground Structures, Moscow, U.S.S.R.

Abstract

According to the generally accepted theory of viscoplastic flow of ice, the velocity of ice flow, related with shear stress by the exponential law (after Glen), is independent of omnidirectional (hydrostatic) pressure. The author's experiment in Antarctica, however, showed that as a result of this pressure effect the flow velocity in the flow of ice decreases with the increasing omnidirectional pressure to some extent. The same effect, but in a still more pronounced form, was noted in frozen ground.

This paper sets forth a theory of viscoplastic flow of ice, taking into account the dependence of flow velocity on omnidirectional pressure.

It is well known that the flow of glaciers and ice shields takes place under conditions of a complex stressed-deformed state, and therefore in order to describe the process of flow it is necessary to know the relationship between all the components of stresses and velocities of deformation. This relationship is usually given in tensor form, the stress tensor being divided into a deviator causing a change of form (flow), and omnidirectional pressure causing a change of volume. The author has suggested a generalized expression defining the relationship between the stress deviator, the velocity deviator and the omnidirectional pressure. Different special cases of this general equation are considered, which may be used as a basis for solving the problem of flow of glaciers and ice shields.

I. Basic Consideration

At present, the theory of plastic flow is widely used to describe the process of ice deformation. The theory establishes the connection between the stress components and the components of the strain speed within the stage of a set, stationary flow. Under the conditions of the pure shear this connection is usually expressed with a power equation, used for ice by Glen and others,

$$\dot{\gamma} = a\tau^\alpha \text{ or } \tau = A\dot{\gamma}^m, \quad (1)$$

where $\dot{\gamma} = d\gamma/dt$ is the speed of relative strain of shear, τ tangential stress, and $\alpha = 1/m$ and $a = (1/A)^\alpha$ are parameters. a depends upon the ice structure and its temperature θ is connected with the following relationship of Roien or Boltzmann

$$a = \frac{K}{1 + |\theta|} \text{ or } a = Ke^{-\frac{Q}{RT}}. \quad (2)$$

Here K , Q , R are constants, while T is absolute temperature.

Under the conditions of the complex stressed state the connection between all the stress components and the strain speed is to be established. This state is determined

* Presented to the Symposium of Pacific-Antarctic Sciences at the Eleventh Pacific Science Congress, Tokyo, 1966.

with tensors of stresses T_σ and tensors of the speeds of strains $T_{\dot{\epsilon}}$, which can be expressed as follows

$$T_\sigma = T'_\sigma + T''_\sigma \quad \text{and} \quad T_{\dot{\epsilon}} = T'_{\dot{\epsilon}} + T''_{\dot{\epsilon}},$$

where T' is spherical tensor and T'' is deviator of stresses; the first of them T' defines the hydrostatic pressure and the volumetric strain caused by the latter, while the second T'' are the shear stress and the strain caused by it. As usual the invariants of the tensors, that is, the generalized values of the stresses and the strains are used. The complex stressed-strained state is rather well defined by the following values:

The intensity of the tangential stresses

$$\sigma_i = \sqrt{\frac{1}{6} \left[(\sigma_x - \sigma_y)^2 + (\sigma_y - \sigma_z)^2 + (\sigma_z - \sigma_x)^2 \right] + \tau_{xy}^2 + \tau_{yz}^2 + \tau_{zx}^2}, \quad (3)$$

the intensity of the speeds of shear strain

$$\dot{\epsilon}_i = \sqrt{\frac{2}{3} \left[(\dot{\epsilon}_x - \dot{\epsilon}_y)^2 + (\dot{\epsilon}_y - \dot{\epsilon}_z)^2 + (\dot{\epsilon}_z - \dot{\epsilon}_x)^2 \right] + \dot{\tau}_{xy}^2 + \dot{\tau}_{yz}^2 + \dot{\tau}_{zx}^2}, \quad (4)$$

the average normal stress (hydrostatic pressure)

$$\sigma = \frac{\sigma_x + \sigma_y + \sigma_z}{3}, \quad (5)$$

the speed of the average strain

$$\dot{\epsilon} = \frac{\dot{\epsilon}_x + \dot{\epsilon}_y + \dot{\epsilon}_z}{3}, \quad (6)$$

where $\sigma_x, \dot{\epsilon}_x = d\epsilon_x/dt$ are normal, and $\tau_{xy}, \dot{\tau}_{xy} = d\tau_{xy}/dt$ are tangential stresses and speeds of strains.

Values σ_i and $\dot{\epsilon}_i$ are the invariants of the deviators of stresses and speeds of strains; sometimes octahedral shearing stresses and speeds of strains $\sigma_n = \sqrt{2/3} \sigma_i$ and $\dot{\epsilon}_n = 2/\sqrt{3} \dot{\epsilon}_i$ are used instead of them. Values σ and $\dot{\epsilon}$ are the invariants of the spherical tensors; when describing the plastic strains it is often assumed that $\dot{\epsilon} = 0$ (the material is incompressible).

Under the conditions of the pure shear the expressions (3) and (4) have the following form

$$\sigma_i = \tau \quad \text{and} \quad \dot{\epsilon}_i = \dot{\tau}, \quad (7)$$

and under the conditions of the uniaxial compression-extension (along axis Z) the following form

$$\sigma_i = \frac{\sigma_z}{\sqrt{3}} \quad \text{and} \quad \dot{\epsilon}_i = \sqrt{3} \dot{\epsilon}_z. \quad (7')$$

The existing theories of plasticity, including the flow theories are based on the supposition that the hydrostatic pressure causes only the volumetric stress and does not affect the change of shape; the latter depends only upon the intensity of tangential stresses, that is

$$\sigma_i = \varphi(\dot{\epsilon}_i) \quad \text{and} \quad \sigma = \varphi^*(\dot{\epsilon}). \quad (8)$$

The first of these expressions means that the connection between stresses and speeds of strains does not depend upon the stressed state and the diagram (Fig. 1 a) characterizing the connection between σ_i and $\dot{\epsilon}_i$ may be obtained from the test for shear of single-axial extension or compression. Actually, if the test for shear of compression gives the power relationship of the type of eq. (1), that is,

$$\tau = A \dot{\gamma}^m \text{ or } \sigma_z = \bar{A} \dot{\epsilon}_z^m, \tag{9}$$

then, by substituting expression (7) for the first one and expression (7') for the second one we obtain a similar equation for the complex stressed state :

$$\sigma_1 = A \dot{\epsilon}_1^m = 3^{-\frac{m+1}{2}} \bar{A} \dot{\epsilon}_1^m. \tag{9'}$$

II. Generalized Flow Equation

Thus, the present theory of flow employed for ice is based on the supposition that the strain process in case of the complex stressed state does not depend upon the hydrostatic pressure. At the same time some investigators state that this pressure has some effect. The author also found indirect proof to this statement. The experiments for shear by a shear instrument (used to test soils) with the simultaneous effect of the compressing stress (without the possibility of the lateral expansion of the specimen) showed that the speed of flow is significantly reduced with an increase in the compressing pressure.

Without considering in detail in what case and to what degree the hydrostatic pressure influences the process of the ice flow, the mathematic theory of the flow which takes into account this influence is given below. We may state that this theory can be applied to any bodies in which compression and extension is different.

Let us investigate the process of the stationary flow. It is evident that the effect of the hydrostatic pressure will reveal itself in the different speed of the flow with different values of this pressure. If the curves of the relationship between the intensity of tangential stresses σ_1 and the intensity of the speed of shear strain $\dot{\epsilon}_1$ are plotted, instead of a single curve, as illustrated in Fig. 1 a, we have a group of curves, each corresponding to its own value of the hydrostatic pressure σ (Fig. 1 b). Such a diagram can be drawn, for instance, from the results of the test for three-axial compression, if each test series have different (but constant) value σ , while value σ_1 is set different for each specimen. Merging of the curves into one curve will testify to the absence of the effect of the hydrostatic pressure (Fig. 1 a), while the group of curves means that such an effect is present. In this case curve $\sigma = 0$ will correspond to the pure shear and will coincide

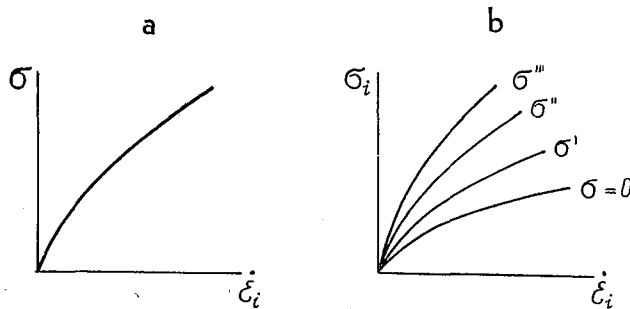

Fig. 1. Relationship between the intensity of tangential stresses σ_1 and intensity of speed of shear strain $\dot{\epsilon}_1$

- a: According to the traditional flow theory
- b: With σ taken the effect of hydrostatic pressure into account

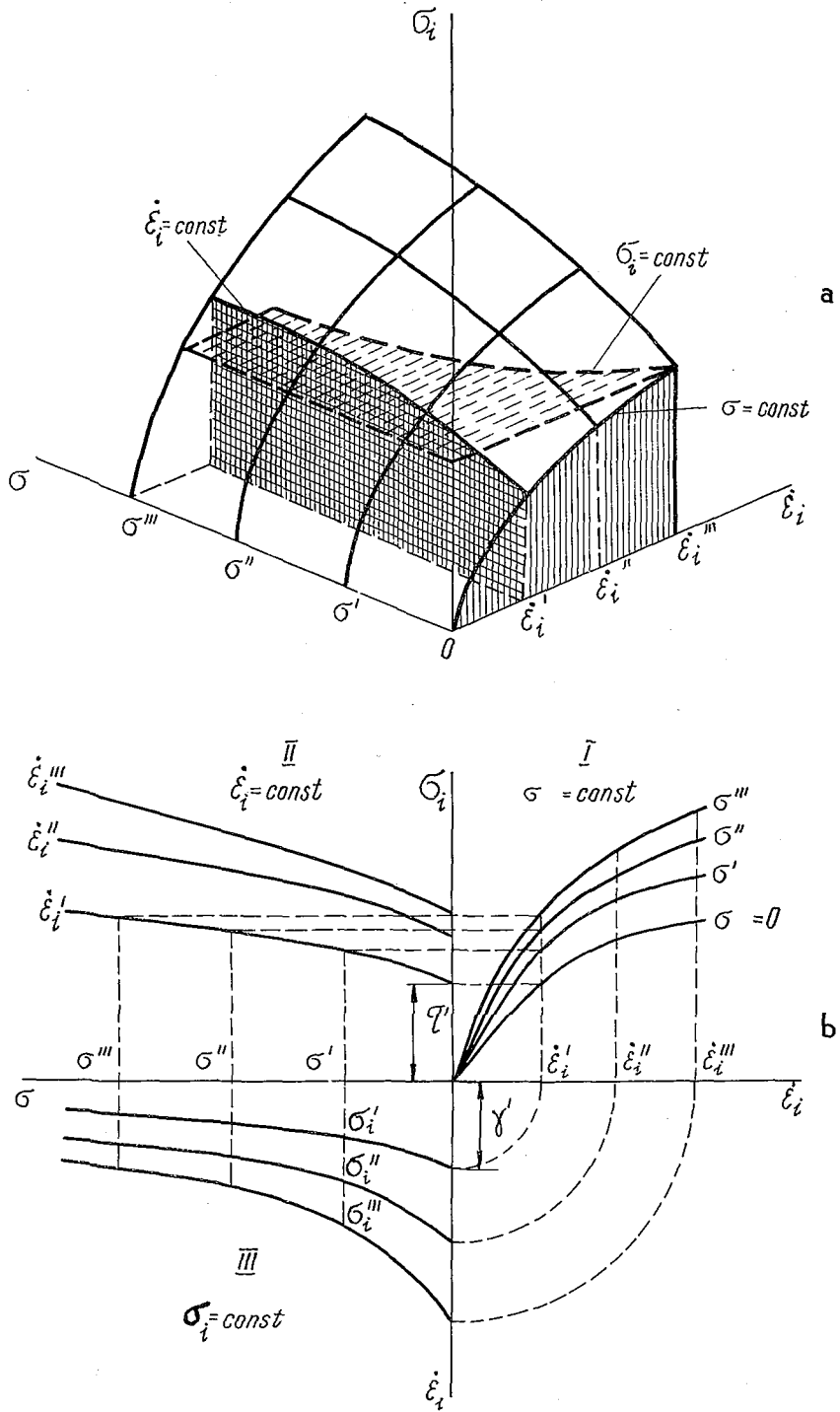

Fig. 2. Surface of flow a and its projection on surface b of $\sigma_i - \sigma$ and $\dot{\epsilon}_i - \sigma$

with the curve illustrated in Fig. 1 a.

To describe the relationship between σ_i and $\dot{\epsilon}_i$ taking into account σ it is evidently necessary to assume a more general condition as given below instead of eq. (8)

$$\sigma_i = \varphi(\dot{\epsilon}_i, \sigma) \text{ and } \sigma = \varphi^*(\dot{\epsilon}_i, \sigma_i), \tag{10}$$

which means that the speed of shear strain $\dot{\epsilon}_i$ depends not only on the intensity of tangential stresses σ_i , but also on the hydrostatic pressure σ , while the speed of the volumetric strains $\dot{\epsilon}$ depends not only upon σ , but also upon σ_i .

The next problem lies in the determination of the type of these relationships, for which purpose one should examine the surfaces, plotted in coordinates $\sigma_i - \dot{\epsilon}_i - \sigma$ and $\sigma - \dot{\epsilon} - \sigma_i$. The first is shown in Fig. 2 a. The projection of the cross-sections of this surface on the respective planes will result in a group of curves $\sigma_i - \dot{\epsilon}_i$ for various σ (similar to the curves illustrated in Fig. 1 b), a group of curves $\sigma_i - \sigma$ for various values of $\dot{\epsilon}_i$ and a group of curves $\dot{\epsilon}_i - \sigma$ for various values of σ_i (Fig. 2 b). It should be noted, that curve $\sigma_i - \dot{\epsilon}_i$ at $\sigma=0$ and sections cut at the X-axis with curves $\sigma_i - \sigma$ and $\dot{\epsilon}_i - \sigma$, will correspond to the pure shear, *i.e.* at $\sigma=0$ we have $\sigma_i = \tau$ and $\dot{\epsilon}_i = \dot{\gamma}$, which can be concluded by comparing eq. (9) with eq. (9').

The analysis of Fig. 2 and the allowance on similarity of curves $\sigma_i - \sigma$ will help to obtain flow eq. (10) which is as follows:

$$\sigma_i = \varphi_1(\dot{\epsilon}_i) + \varphi_2(\dot{\epsilon}_i) \phi(\sigma), \tag{11}$$

where $\varphi_1(\dot{\epsilon}_i)$ characterizes the relationship between the stress and the speed of strain in the case of pure shear, *i.e.* $\varphi_1(\dot{\epsilon}_i) = \tau$ is the equation of curve $\sigma_i - \dot{\epsilon}_i$ for $\sigma=0$ (quadrant I, Fig. 2 b); $\phi(\sigma)$ characterizes the effect of the hydrostatic pressure, *i.e.* the angle of inclination of curves $\sigma_i - \sigma$ (quadrant II, Fig. 2 b), and φ_2 defines the relationship of this angle on the speed of flow $\dot{\epsilon}_i$. Thus, the first member of eq. (11) reflects the flow with the pure shear, while the second one indicates the effect of the hydrostatic pressure σ expressed by an increase in resistance to the shear with an increase of σ (a braking effect in flow is seen).

A similar method can be used to obtain the equation for the volumetric strains likewise.

With sufficient accuracy curves $\sigma_i - \sigma$ (quadrant II, Fig. 2 b) can be approximated as straight lines. Then the function $\phi(\sigma) = \sigma$, while the function φ_2 gives the value $\varphi_2(\dot{\epsilon}_i) = \text{tg } \psi(\dot{\epsilon}_i)$, where $\psi(\dot{\epsilon}_i)$ is the angle of inclination of straight lines $\sigma_i - \sigma$, depending upon the speed of flow $\dot{\epsilon}_i$. Equation (11) will have the following expression:

$$\sigma_i = \varphi_1(\dot{\epsilon}_i) + \varphi_2(\dot{\epsilon}_i) \sigma$$

or

$$\sigma_i = \tau(\dot{\epsilon}_i) + \sigma \text{tg } \psi(\dot{\epsilon}_i) [1 + \sigma/H(\dot{\epsilon}_i)], \tag{12}$$

where

$$H = \tau/\text{tg } \psi.$$

The function φ_1 is assumed in compliance with the relationship (9'); a similar relationship is assumed for the function φ_2 as well:

$$\varphi_1(\dot{\epsilon}_i) = \tau(\dot{\epsilon}_i) = A \dot{\epsilon}_i^m \text{ and } \varphi_2(\dot{\epsilon}_i) = \text{tg } \psi(\dot{\epsilon}_i) = B \dot{\epsilon}_i^n, \tag{13}$$

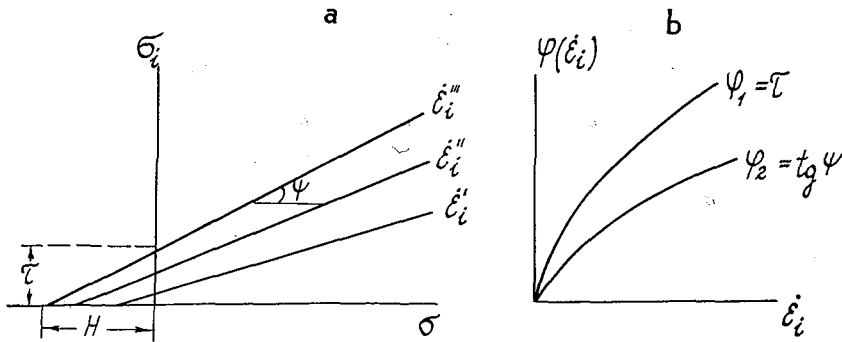

Fig. 3. Graphs of main relationships between the intensity of stresses σ_i , the intensity of strains $\dot{\epsilon}_i$ and the hydrostatic pressure σ

Then the eq. (12) is rewritten as follows:

$$\sigma_i = A \dot{\epsilon}_i^m + B \sigma \dot{\epsilon}_i^n. \quad (14)$$

This very equation should be investigated as a generalized rheological equation of state (flow equation) with the effect of the hydrostatic pressure. The first term of the equation still reflects the pure shear, while the second one reflects the effect of the mean pressure. The graph illustration of the equation is given in Fig. 3. On the left (Fig. 3 a) a group of straight lines $\sigma_i - \sigma$ for various $\dot{\epsilon}_i$ is shown, eq. (12) serves as an equation for these straight lines. On the right (Fig. 3 b) is shown the curve of the relationship between σ_i and $\dot{\epsilon}_i$, reflecting the function $\varphi_1(\dot{\epsilon}_i) = \tau$, and the curve of relationship between $\text{tg } \psi$ and $\dot{\epsilon}_i$, reflecting the function $\varphi_2(\dot{\epsilon}_i) = \text{tg } \psi$. Thus, to use eq. (14) it is necessary to experimentally define the values of parameters A , B , m and n . Parameters A and m are defined either directly from the experiments for pure shear, as it is usually done or from the experiments with the complex stressed state with $\sigma = 0$. Parameters B and n are determined from the tests with the complex stressed state (three-axial compression, twisting with simultaneous effecting of compressing or extending stress, etc.) with various values of $\sigma = \text{const.}$ by means of plotting the graphs of the type illustrated in Fig. 3. The graphs shown in Fig. 3b are to be replotted on the logarithmic scale. The sections cut by straight lines $\ln \sigma_i - \ln \dot{\epsilon}_i$ and $\ln \text{tg } \psi - \ln \dot{\epsilon}_i$ at the ordinate axes in this case will determine the respective values $\ln A$ and $\ln B$, while the tangents of the inclination angles of these straight lines will determine values m and n , respectively.

III. Relation between the Stress and the Rate of Flow

To solve the problem of the determination of the stressed-strained state of the massif with due regard to the effect of hydrostatic pressure, eq. (14) is to be substituted into Genka's condition determining the connection between the components of the stresses and the speeds of strains.

$$\begin{aligned} \dot{\epsilon}_x - \dot{\epsilon} &= \chi(\sigma_x - \sigma) \text{ etc.}, \\ \dot{\gamma}_{xy} &= 2\chi \tau_{xy} \text{ etc.}, \end{aligned}$$

where

$$\chi = \frac{\dot{\epsilon}_i}{2\sigma_i} = \frac{\dot{\epsilon}_i^{1-n}}{2(A\dot{\epsilon}_i^{m-n} + B\sigma)} \quad (15)$$

If the hydrostatic pressure is not taken into account the factor χ (plasticity factor) assumes its usual form.

$$\chi = \frac{\dot{\epsilon}_i^{1-m}}{2A}$$

If the volumetric strains are neglected it can be supposed that $\dot{\epsilon} = 0$.

Equations (13) and (14) are significantly simplified when φ_1 and φ_2 are similar with each other, *i.e.* when $m=n$. This means that a group of straight lines $\sigma_i - \sigma$ for various $\dot{\epsilon}_i$ (Fig. 3 a) begins at one point ($H = \text{const.}$) and is transformed into one straight line, if the latter is plotted in coordinates $\sigma_i/\tau - \sigma$ (Fig. 4 a). Similarly, the curves of functions φ_1 and φ_2 merge into one curve if the latter is plotted in coordinates $\left[\frac{\sigma_i}{1+\sigma/H}\right] - \dot{\epsilon}_i$ (Fig. 4 a). Then, eq. (13) will be expressed as follows:

$$\sigma_i = \dot{\epsilon}_i^m (A + B\sigma) = A\dot{\epsilon}_i^m \left(1 + \frac{\sigma}{H}\right) \quad (16)$$

Equation (15) will also be rewritten as follows:

$$\chi = \frac{\dot{\epsilon}_i^{1-m}}{2(A+B\sigma)} = \frac{\dot{\epsilon}_i^{1-m}}{2A(1+\sigma/H)} \quad (17)$$

In this case both the determination of parameters (there remain only three of them A , B , and m) and the very solution of the problem are significantly simplified.

Another special case is when $n=0$ (Fig. 4 b).

$$\sigma_i^m = A\dot{\epsilon}_i^m + B\sigma \quad (18)$$

Finally the case when $m-n=1$, or $m=1$, $n=0$, corresponds to the linear one which

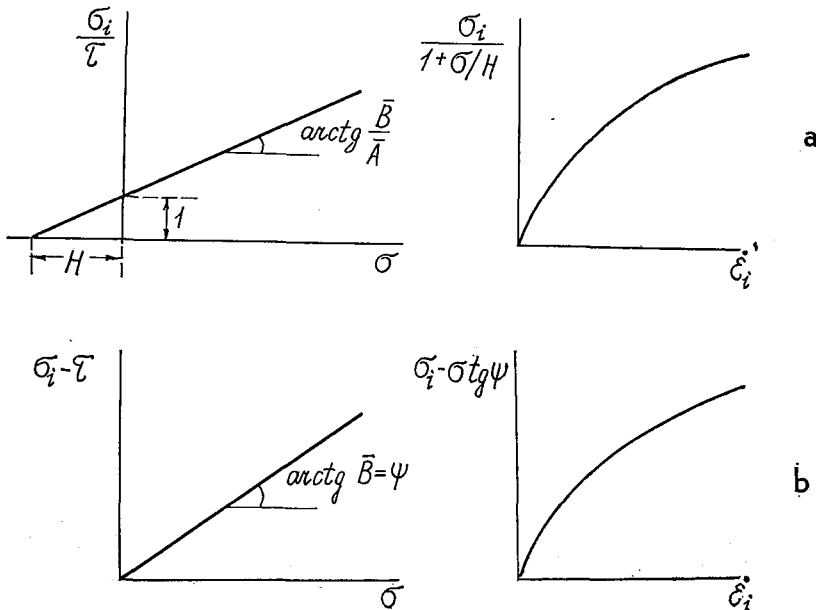

Fig. 4. Special cases of eq. (14) a: $m=n$, b: $n=0$

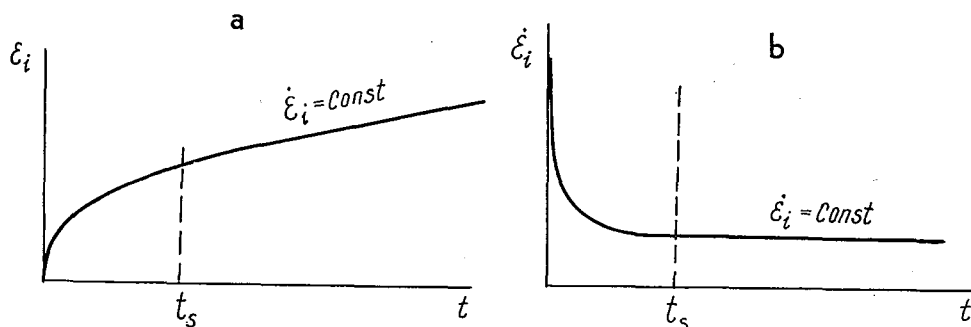

Fig. 5. Development of strains with time a and change of their speeds b

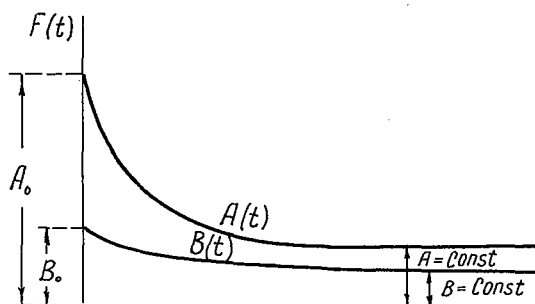

Fig. 6. Change of parameters A and B with time

is the Newton flow law with due regard to the mean pressure.

The above described case indicates a stationary flow with constant speed of $\dot{\epsilon}_i = \text{const}$. In general case, at the initial period the strain occurs with an ever-slowing down speed which is a function of time $\dot{\epsilon}_i = f(t)$ and after a short time t_s becomes constant (Fig. 5). This can be taken into consideration when investigating parameters A and B , as a time function t (Fig. 6) reflecting a change in the flow speed. Then eq. (14) will be

$$\sigma_1 = A(t) \dot{\epsilon}_i^m + B(t) \sigma \dot{\epsilon}_i^n. \quad (19)$$

Hence, the factor α from eq. (15) will also be a function of t .

Parameters A and B change with time so that at the initial period ($t=0$) they have the maximum value A_0 and B_0 corresponding to the speed of strains with the momentary application of load (this value can be assumed with $A_0 = B_0 = \infty$), and at a certain period of time t_s they assume constant values $A = \text{const}$. and $B = \text{const}$. Apparently B depends on time to a lesser extent. The expression of functions $A(t)$ and $B(t)$ is determined experimentally.

It should be said in conclusion that parameters A and B depend upon the temperature and that A is subjected to the relationship (2).