



# HOKKAIDO UNIVERSITY

Title	An Attempt to Clarify Triaxial Creep Mechanics of Snow
Author(s)	Salm, Bruno
Description	International Conference on Low Temperature Science. I. Conference on Physics of Snow and Ice, II. Conference on Cryobiology. (August, 14-19, 1966, Sapporo, Japan)
Citation	Physics of Snow and Ice : proceedings, 1(2), 857-874
Issue Date	1967
Doc URL	<a href="https://hdl.handle.net/2115/20347">https://hdl.handle.net/2115/20347</a>
Type	departmental bulletin paper
File Information	2_p857-874.pdf



# An Attempt to Clarify Triaxial Creep Mechanics of Snow

Bruno SALM

*Federal Institute for Snow and Avalanche Research  
Weissfluhjoch, Davos, Switzerland*

---

## Abstract

From the basis of a chosen constitutive equation, an attempt was made to expand for snow a derived relationship for the state of simple shearing between shear rate and applied shear stress (hyperbolic sine function) at general states of stress. The general rate of deformation of snow was for this purpose split in the mechanism of a pure shear deformation and a pure cubical dilatation. The influence of the state of deformation upon the *viscosity* (that is shear viscosity) was considered with a "bulk viscosity function" and a "viscosity function". These functions are on their part dependent on the first and second basic invariants of the rate of deformation respectively. The *bulk viscosity* was on the other hand only as a function of the first basic invariant established.

Experiments with uniaxial tensile and compressive states of stress and with a uniaxial state of deformation are discussed in regard to this theory.

---

## I. Introduction

It has long been known that the rate of deformation of a snow sample is dependent in complicated ways upon the state of stress under which the sample is subjected. For example the rate of deformation under a uniaxial state of stress is very different depending on whether it is a compressive or tensile stress. Further it seems that certain properties of the material, for example the viscosity and Poisson's ratio, are not real constants of the continuum. These phenomena are closely related to the distinct and great compressibility of snow. Haefeli (1939, 1942) was the first to experimentally recognize these complicated behaviours and distinguished between rate of deformation and Poisson's ratio under compressive and tensile stress in his calculations. Bucher (1948) attempted to explain the difference between compressive and traction deformation by a shrinkage stress. Landauer (1957) carried out experiments where he subjected the same kind of snow to various states of stress. He recognized that with snow, the superposition of states of stress clearly did not result in a similar superposition of the states of deformation (as for example with an elastic body). That means that non-linear relationships between the statical and kinematical quantities must exist, or that the snow has a non-Newtonian behaviour.

## II. Theoretical Foundations

Snow under natural conditions is subjected to a large number of influencing factors. To win an insight into the triaxial behaviour, it is necessary to eliminate the maximum possible number of outside influences and to only include those which have a decisive

influence. More influences should not be included than it is possible ultimately to differentiate between.

First of all the temperatures must be maintained at a constant level. The structure, grain shape and size of the snow must experience no change. That means that the proceeding should be considered in as short a time as possible during which no significant influence from metamorphosis appears. Also no significant change in the density and in the number of existing bindings between adjacent grains should occur. Further only snow types of the seasonal snow cover should be considered, which have a maximum specific gravity of approximately  $0.5 \text{ g-wt-cm}^{-2}$ . Obviously the air trapped within the snow should be to escape without hindrance.

One very important, as well as critical question is whether or not *isotropy* may be presumed. Existing investigations recognize both mechanical isotropic and also anisotropic behaviour. In order to avoid undue complications, isotropy will be preliminarily assumed.

A constitutive equation shall be chosen which is as simple as possible but which still allows the most important characteristics to be described. The following equation which presumes isotropy will be used, where  $T_{ij}$  are the stress components:

$$T_{ij} = \lambda V_{kk} \delta_{ij} + 2\mu V_{ij}. \quad (1)$$

This equation is similar to Hooke's law, with the difference in that on the right side of eq. (1), it is concerned with deformation *rate* rather than *deformation*. Because snow knows no yield stress and also because body forces never cease acting, there is no possibility for a state of rest to be reached. This state of affairs has been properly translated in eq. (1). The definition of a pressure "*p*"—this pressure being independent from the rate of deformation—becomes then superfluous.

The so called Lamé's Constants,  $\lambda$  and  $\mu$ , are now somehow dependent upon the rate of deformation. Being a scalar,  $\lambda$  and  $\mu$  can not depend in an arbitrary manner on the components of the rate of deformation. They must be a function of expressions in these components that are themselves scalars. It can be shown that for these scalars, it is sufficient to consider the *basic invariants*  $\mathcal{V}_{(1)}$ ,  $\mathcal{V}_{(2)}$  and  $\mathcal{V}_{(3)}$  of the rate of deformation (Prager, 1961).

The problem is now to find a clue how  $\lambda$  and  $\mu$  would depend on the basic invariants.

Kauzmann (1941) has theoretically derived the following formula for the dependence of the rate of shear on the applied shear stress:

$$2V_{12} = \sum_z A_z \sinh \alpha_z T_{12}. \quad (2)$$

$2V_{12}$  is therein the rate of shear and  $T_{12}$  is the shear stress by a condition of pure shear. The summation over "*z*" means that the total rate of shear deformation from various components (that is various shear mechanisms) can be combined.  $A_z$  and  $\alpha_z$  are for the mechanisms in question the related constants.

The general rate of deformation of snow will here be split in *two mechanisms*, and these are:

- (1) pure shear deformation (under constant volume),
- (2) pure change in volume.

For the state of stress, this means nothing else than that it is to be split into a *stress deviator* and a *hydrostatic state of stress*:

$$T_{ij} = T'_{ij} + \mathcal{J} \delta_{ij}. \tag{3}$$

$T'_{ij}$  is the stress deviator, for which  $T'_{ij}=0$  and  $\mathcal{J}$  is the mean normal stress:

$$\mathcal{J} = -\frac{1}{3} T_{kk}. \tag{4}$$

When eq. (1) is solved for  $V_{ij}$ :

$$V_{ij} = \frac{1}{2\mu} \left( T'_{ij} - \frac{\lambda}{3\lambda + 2\mu} T_{kk} \delta_{ij} \right), \tag{5}$$

it is true for the deviator state of stress:

$$V_{ij} = -\frac{1}{2\mu} T'_{ij}. \tag{6}$$

Moreover for the hydrostatic state of stress, it is according to eq. (5)

$$V_{ij} = \frac{\mathcal{J} \delta_{ij}}{3\lambda + 2\mu}, \tag{7}$$

where  $\mathcal{J}$  is the mean acting normal stress.

II. 1. *Pure shear deformation.* In accordance with eq. (6), the assumption can be made:

$$V_{ij} = \frac{F_s}{2\mu_0} T'_{ij}. \tag{8}$$

$F_s$  is a "viscosity function" dependent from the basic invariants.  $\mu_0$  is the viscosity for  $\mathcal{J}_{(2)}=0$ .

The double contracted product from eq. (8) when solved for  $F_s$  yields:

$$F_s = \frac{2\mu_0 \mathcal{J}_{(2)}^{1/2}}{\mathcal{J}'_{(2)}^{1/2}}. \tag{9}$$

The Kauzmann relationship eq. (2) was actually derived only for the state of simple shearing stress. This relationship will be here hypothetically generalized. Equation (2) in a series develops as follows:

$$V_{12} = A T_{12} \left( 1 + \frac{\alpha^2}{3!} T_{12}^2 + \frac{\alpha^4}{5!} T_{12}^4 + \dots \right). \tag{10}$$

The basic invariant  $\mathcal{J}'_{(2)}$  has for the state of simple shearing stress the magnitude  $T_{12}^2$ . This suggests to substitute:

$$V_{ij} = A T'_{ij} \left( 1 + \frac{\alpha^2}{3!} \mathcal{J}'_{(2)} + \frac{\alpha^4}{5!} \mathcal{J}'_{(2)}^2 + \dots \right). \tag{11}$$

Equation (11) can be again transformed for the state of simple shearing stress. For  $A = \frac{1}{2\mu_0}$  the viscosity function reads:

$$F_s = 1 + \frac{\alpha^2}{3!} \mathcal{J}'_{(2)} + \frac{\alpha^4}{5!} \mathcal{J}'_{(2)}^2 + \dots. \tag{12}$$

It is unfortunately not possible to solve eq. (12) for  $\mathcal{J}'_{(2)}$  to substitute the result in eq. (9),

and in this manner to solve eq. (9) for  $F_s$ . To recognize how the viscosity function depends on the two basic invariants, eq. (9) is solved for  $\mathcal{V}'_{(2)}$  and substituted in eq. (12):

$$F_s = 1 + \frac{4\alpha^2\mu_0^2\mathcal{V}'_{(2)}}{3!F_s^2} + \frac{16\alpha^4\mu_0^4\mathcal{V}'_{(2)}^2}{5!F_s^4} + \dots \quad (13)$$

For  $F_s$  values which are not too large, the series may be broken after the third term. With

$$\alpha'^2 = 4\alpha^2\mu_0^2, \quad (14)$$

the following is produced:

$$\mathcal{V}'_{(2)} = \frac{10F_s^2}{\alpha'^2} \left( -1 \pm \sqrt{\frac{1}{5}(6F_s - 1)} \right) \quad (15)$$

Because the basic invariant  $\mathcal{V}'_{(2)}$

$$\mathcal{V}'_{(2)} = V_{12}^2 + V_{13}^2 + V_{23}^2 - V_{11}V_{22} - V_{11}V_{33} - V_{33}V_{22}, \quad (16)$$

(for example with the rate of deformation  $V_{12} = V_{13} = V_{23} = 0$  and  $V_{11} = V_{22} = V_{33}$ ) can become negative, its absolute value  $|\mathcal{V}'_{(2)}|$  is to be used.

II. 2. *Pure volume dilatation.* In consequence of eq. (7), the following formulation can be made:

$$V_{ij} = \frac{F_v}{3\mu_{v0}} \mathcal{I} \delta_{ij}. \quad (17)$$

$F_v$  is the so called "bulk viscosity function" depending on the basic invariants.  $\mu_{v0}$  is the bulk viscosity for the vicinity of  $\mathcal{V}'_{(1)} = 0$ . Contraction of eq. (17), solved for  $F_v$  gives:

$$F_v = \frac{\mu_{v0}\mathcal{V}'_{(1)}}{\mathcal{I}'_{(1)}}. \quad (18)$$

Change in volume is ultimately based upon shear deformation along the contact areas of the snow grains. The Kauzmann relationship shall therefore again be generalized:

$$V_{ij} = B\mathcal{I}'\delta_{ij} \left( 1 + \frac{\beta^2\mathcal{I}'^2_{(1)}}{3!} + \frac{\beta^4\mathcal{I}'^4_{(1)}}{5!} + \dots \right). \quad (19)$$

For  $B = \frac{1}{3\mu_{v0}}$ , the bulk viscosity function reads:

$$F_v = 1 + \frac{\beta^2\mathcal{I}'^2_{(1)}}{3!} + \frac{\beta^4\mathcal{I}'^4_{(1)}}{5!} + \dots \quad (20)$$

Equation (18) is then solved for  $\mathcal{I}'_{(1)}$  and in eq. (20) substituted:

$$F_v = 1 + \frac{\beta^2\mu_{v0}^2\mathcal{V}'^2_{(1)}}{3!F_v^2} + \frac{\beta^4\mu_{v0}^4\mathcal{V}'^4_{(1)}}{5!F_v^4}. \quad (21)$$

For values of  $F_v$  which are not too large, the series may be broken after the third term. With

$$\beta' = \beta\mu_{v0}, \quad (22)$$

then it yields:

$$\mathcal{V}'^2_{(1)} = \frac{10F_v^2}{\beta'^2} \left( -1 \pm \sqrt{\frac{1}{5}(6F_v - 1)} \right). \quad (23)$$

Because of the relationship

$$\mu_v = \lambda + \frac{2}{3} \mu, \tag{24}$$

it can be written that:

$$\lambda + \frac{2}{3} \mu = \frac{\lambda_0}{F_v} + \frac{2}{3} \frac{\mu_0}{F_v F_s}, \tag{25}$$

where the index 0 shall indicate the first vanishing basic invariant. Equation (25) shows that the influence of the first basic invariant on the viscosity  $\mu$  is given by the bulk viscosity function. Since  $\lambda_0 \gg \frac{2}{3} \mu_0$ , the dependence of  $\mu_v$  from  $\mathcal{V}_{(2)}$  may be disregarded.

II. 3. *Summary.* It has been assumed that only the first and the second basic invariants of the rate of deformation

$$\left. \begin{aligned} \mathcal{V}_{(1)} &= V_{11} + V_{22} + V_{33} \\ \mathcal{V}_{(2)} &= V_{12}^2 + V_{13}^2 + V_{23}^2 - V_{11}V_{22} - V_{11}V_{33} - V_{33}V_{22} \end{aligned} \right\}, \tag{26}$$

influence the viscosities  $\mu$  and  $\mu_v$ . The third was not included although this could be done without difficulty; the cost however would be a loss of clarity.

For the *viscosity*  $\mu$ , the following relationship has been established:

$$\mu = \frac{\mu_0}{F_v^s F_s}. \tag{27}$$

$\mu_0$  is therein the viscosity for  $F_v^s = F_s = 1$ , consequently  $\mathcal{V}_{(1)} = \mathcal{V}_{(2)} = 0$ .  $F_v^s$  depends on  $\mathcal{V}_{(1)}$ , as shown in eq. (21). On the other hand  $F_s$  is, in accordance to eq. (13), a function of  $\mathcal{V}_{(2)}$ .

The *bulk viscosity*  $\mu_v$  is:

$$\mu_v = \frac{\mu_{v0}}{F_v}. \tag{28}$$

$\mu_{v0}$  is therein an ideal bulk viscosity for the vicinity of  $F_v = 1$ , consequently where  $\mathcal{V}_{(1)} \cong 0$ , that is for the approximately volume constant behaviour. When  $\mathcal{V}_{(1)}$  is exactly zero, the eq. (28) is only correct with  $\mu_{v0} = \infty$ . For values of  $F_v$  which are not too small, the selection of  $\mu_{v0}$  is however not especially meaningful, since it is more or less true (as it can be shown with eq. (21)) that:

$$\frac{\mu_{v0}}{F_v} = \frac{\mu_{v0}}{\text{const. } \mathcal{V}_{(1)} \mu_{v0}} = \frac{1}{\text{const. } \mathcal{V}_{(1)}}. \tag{29}$$

Furthermore there is the supposition originally made that the specific gravity of snow types here considered are not too close the specific gravity of ice so that in general, no volume constant movements are to be expected.

The relationships eqs. (27) and (28) can be illustrated in a system of coordinates with the axis  $\mu, \mu_v$  respectively,  $\mathcal{V}_{(1)}$  and  $\mathcal{V}_{(2)}$  (Fig. 1). Equation (27) supplies an area there with an absolute maximum in  $\mathcal{V}_{(1)} = \mathcal{V}_{(2)} = 0$  for which  $\mu = \mu_0$ . The intersecting curve of the plain  $\mathcal{V}_{(2)} = \text{constant}$  with the surface, has in  $\mathcal{V}_{(1)} = 0$  a relative maximum with a horizontal tangent. The intersecting curve of the plain  $\mathcal{V}_{(1)} = \text{constant}$  with the surface, has in  $\mathcal{V}_{(2)} = 0$  a relative maximum with a discontinuity in the first derivative.

### III. Apparatus

III. 1. *Requirements.* The apparatus must be so constructed to enable fulfillment of the conditions stated at the beginning of Part 2. The most important requirement is for a large as possible exact deformation measurement, because amounts of practically *instantaneous* rates of deformations are to be registered. In addition the parts of the apparatus which transmits forces to the snow sample must lay very exactly thereon; otherwise unequal stress distribution will result.

This demands on one hand that the device itself be precisely made (parallel planes) and on the other hand that the snow sample be very exactly cut.

It should be possible to introduce stress values of over  $1\,000\text{ g-wt-cm}^{-2}$ , which approximately corresponds to the maximum magnitude of stress which may occur in the seasonal snowpack.

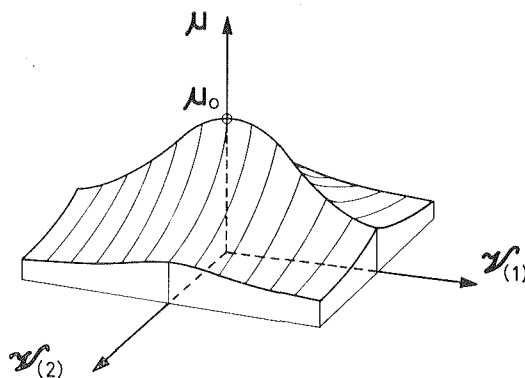

Fig. 1. Viscosity as a function of the basic invariants  $\mathcal{V}_{(1)}$  and  $\mathcal{V}_{(2)}$

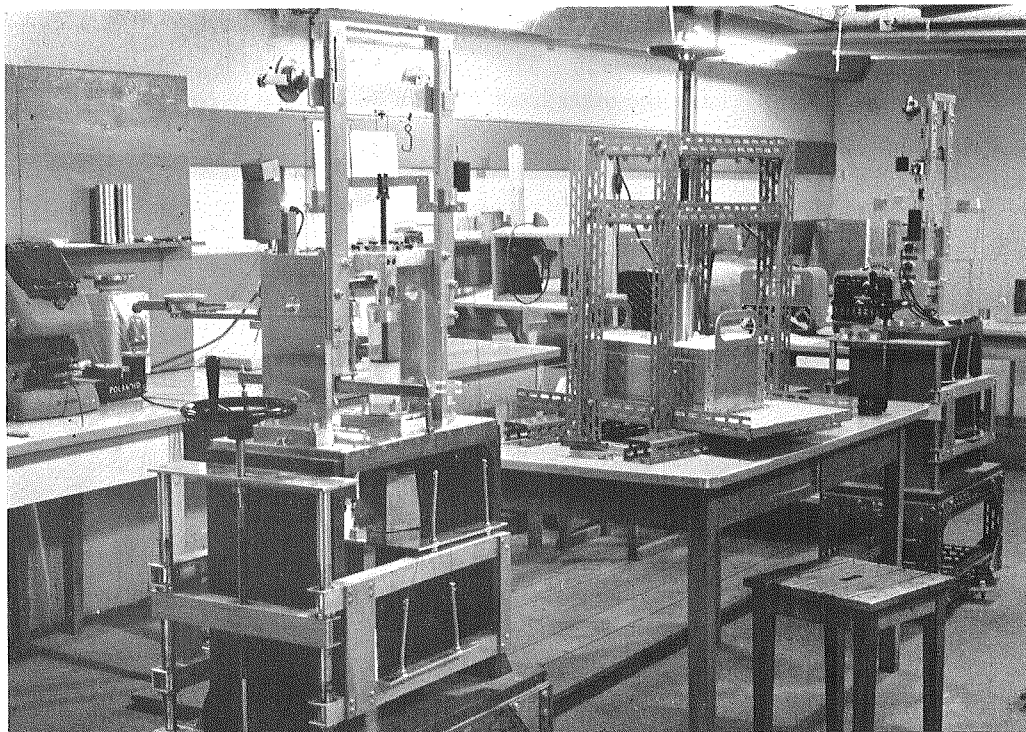

Fig. 2. Apparatus

Left: Apparatus for the uniaxial state of tensile and compressive stress

Middle: Device to cut out the snow samples

Right: Apparatus for the uniaxial state of deformation. (Photo SLF)

III. 2. *Preparation of the snow samples.* The snow samples are removed from layers of natural snow with a tubular probe in the laboratory. For this purpose a device has been especially constructed (Fig. 2). In order to avoid a tilting of the probe during the sampling, it is steadied along its axis with two guiderods. The probe supporter is operated by a hand-turned screw jack. In the probe which has a total length of 15 cm are formed two slits 10 cm apart—the height of the sample. With a precise, grinded saw which passes exactly through the slits, the excess snow is sawed off. The sample is pushed from the probe with a piston.

III. 3. *Apparatus for the uniaxial compressive and tensile state of stress (Fig. 3).* The round samples are 10 cm long and have a diameter of 5.8 cm. The tensile-sample is frozen with a special device to the plates which will apply the stress. This is the most delicate phase of the experiment preparation. The compressive-sample is placed between two plates which are covered with Teflon and treated with Silicon grease.

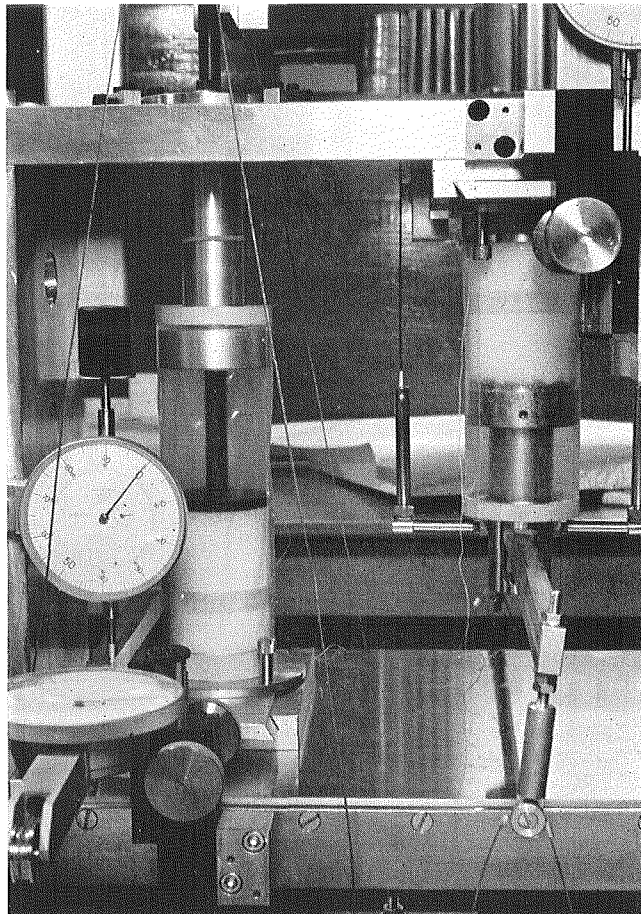
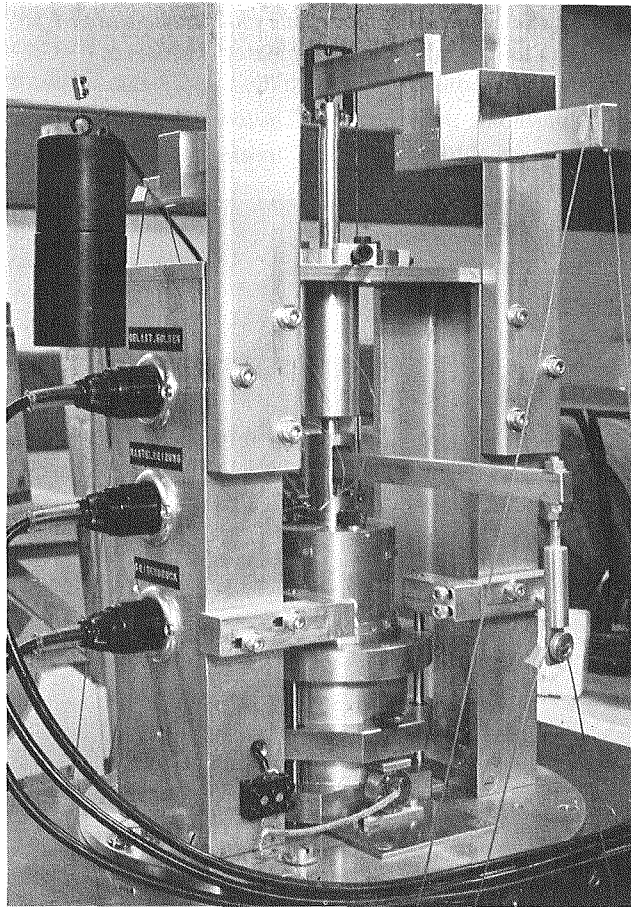

Fig. 3. Left: Apparatus for the uniaxial state of compressive stress  
 Right: Apparatus for the uniaxial state of tensile stress.  
 (Photo SLF)

For the measurement of the axial deformation, mechanical dial-gauges with a reliability of  $\pm 1 \times 10^{-4}$  cm are used. The lateral rate of deformation is measured with a Teflon band placed around the sample. For this purpose a dial-gauge is also used. The height of the band is continually adjusted to the progressive axial deformation. To protect against evaporation, a plastic hull is inverted over the snow sample. A preliminary weighting (in both cases a compressive stress of 5-10% of the maximum weight) causes the complete adaption of the snow sample's surface to the parts of the apparatus which transmits forces.



**Fig. 4.** Apparatus for the uniaxial state of deformation. In the lower center, the ring "F" for measurement of the friction forces. (Photo SLF)

III. 4. *Apparatus for the uniaxial state of deformation under compressive stresses (Fig. 4).* The round samples are 10 cm long and have a diameter of 8.2 cm. The most difficult problems lie in the friction forces which occur on the side walls and are neces-

**Fig. 5.** Schematic drawing of the apparatus for the uniaxial state of deformation. "R" is the weighting of the circular ring with which the friction on the side walls is compensated for. "G" is the weighting of the inner piston. With ring "F" is the friction force, and with ring "L" is the side pressure measured,  $C_G$  and  $C_R$  are compensation weights

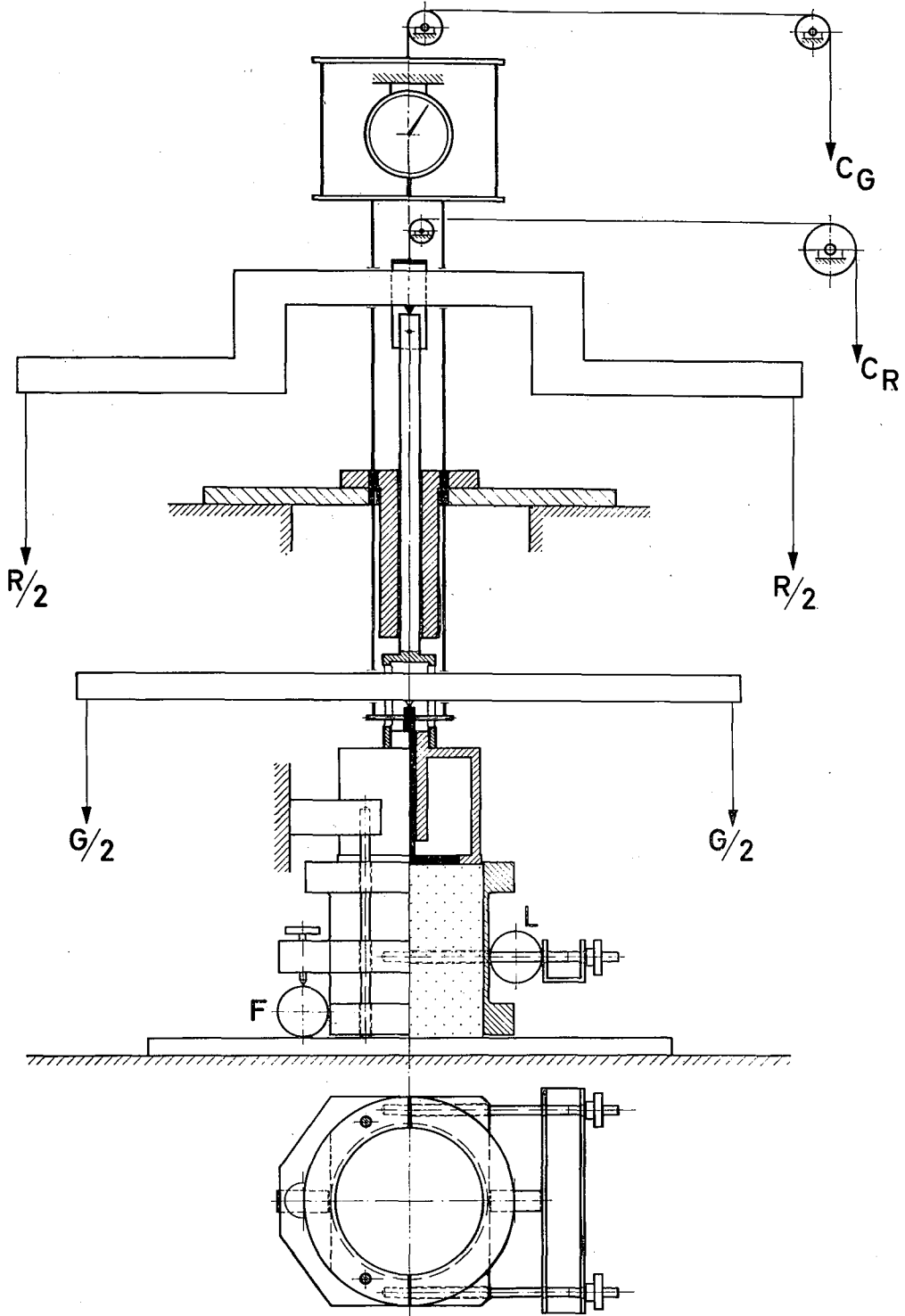

Fig. 5.

sitated in order to produce the uniaxial state of deformation.

The apparatus is so constructed that these friction forces remain under control and can be compensated for (Fig. 5). The snow sample is weighted on one hand with a circular inner piston (diameter 5.8 cm, load  $G$ ), and on the other hand with an outer ring (inner diameter 5.8 cm, outer diameter 8.2 cm, load  $R$ ). As soon as friction forces appear, this outer ring is weighted correspondingly more. The tubular side-wall is in the axial direction of the snow sample freely moveable. It is supported by a ring  $F$  from which the support-force of the side-wall can be measured using strain-gauges. As soon as the support-force increases, the appearance of a corresponding friction-force is indicated and the load  $R$  on the outer ring can be correspondingly increased. The side-wall is split into two halves along a plane through the snow sample axis. One of these halves is horizontally freely moveable. The force necessary to hold the two sides together is measured again with a ring  $L$ , using also strain-gauges. The deformation of the snow is measured with a dial-gauge as explained in part III. 3. Also an initial weighting of 5–10% of the maximum weight was used.

#### IV. Experiments

IV. 1. *General Comments.* In the natural snow pack at Weissfluhjoch, old snow layers are sought out which are so much as possible homogeneous in form, grain shape, density and structure. Generally no interlayers were observed. The winter 1965/66, during which these experiments were carried out, was for these conditions favourable. After field-removal, the snow was stored for approximately one month at  $-5^{\circ}\text{C}$  in the laboratory. *Table 1* gives the characteristics of the snow used in the experiment. Within the experiment numbering, the last digit of the number stands for the state of stress-respective to state of deformation:

- .1 is the uniaxial tensile state of stress,
- .2 is the uniaxial compressive state of stress, and
- .3 is the uniaxial state of deformation.

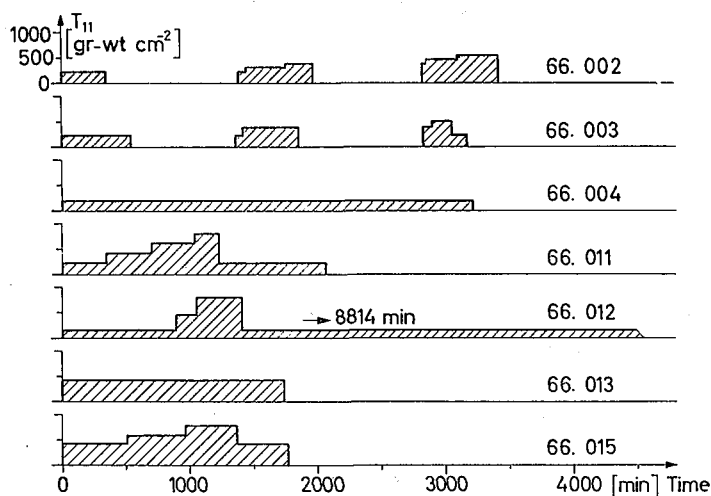

Fig. 6. Axial stress magnitude  $T_{11}$  as a function of time

Table 1

Experiment	Specific gravity $\gamma_0$	$\frac{\gamma_E}{\gamma_0} = \frac{\text{final spec. gravity}}{\text{initial spec. gravity}}$	Tensile strength (Temperature)	Hardness (Hardness gage H 45 SLF)	Air permeability (Apparatus de Quervain-Wolgroth)	Grain size	Viscosity <i>normal</i> to the snow layer (Magnitude of applied stress $T_{II}$ )	Viscosity <i>parallel</i> to the snow layer (Magnitude of applied stress $T_{II}$ )	Temperature during the experiment
	$\text{g}\cdot\text{cm}^{-3}$		$\text{g}\cdot\text{wt}\cdot\text{cm}^{-2}$ ( $^{\circ}\text{C}$ )	$\text{g}\cdot\text{wt}\cdot\text{cm}^{-2}$	$\text{cm}\cdot\text{sec}^{-1}/$ $\text{mbar}\cdot\text{cm}^{-1}$	mm	$\text{dyne}\cdot\text{sec}\cdot\text{cm}^{-2}$ ( $\text{g}\cdot\text{wt}\cdot\text{cm}^{-2}$ )		$^{\circ}\text{C}$
66.002	0.410		1130 (-3.5)	5900	51.1	0.45			- 4.7 ± 0.8
.1		0.988							
.2		1.036							
.3		1.047							
66.003	0.416		610 (-4.0)	6000	51.8	0.35			- 4.6 ± 1.0
.1		0.998							
.2		1.037							
.3		1.045							
66.004	0.404		1560 (-4.5)	5200	53.6	0.35			- 4.6 ± 1.3
.1		0.995							
.2		1.045							
.3		1.041							
66.001.2							20.35 (421.6)	22.72 (421.6)	- 4.1 ± 0.4
66.011	0.456		2090 (-4.5)	6100	77.2	0.65			- 4.4 ± 0.6
.1		0.998							
.2		1.011							
.3		1.013							
66.012	0.460		1610 (-4.5)	8500	74.2	0.75			- 5.1 ± 0.3
.1		0.999							
.2		1.011							
.3		1.014							
66.013	0.454		1390 (-3.0)	7600	77.2	0.65			- 4.8 ± 0.2
.1		1.000							
.2		1.002							
.3		1.004							
66.015	0.466		2300 (-4.0)	9600	74.6	0.80			- 4.7 ± 0.3
.1		1.000							
.2		1.006							
.3		1.008							
66.014.2							174.26 (428.0)	82.02 (428.0)	- 5.3 ± 0.3

The snow samples of the trials 66.001 to 66.004 on one hand and 66.011 to 66.015 on the other hand come from the same snow layer, and therefore should exhibit approximately the same characteristics. All snow samples were cut perpendicular to the snow layering, with the exception of those used for the special experiments 66.001.2 and 66.014.2.

After some hours of prior weighting, various axial stresses  $T_{11}$  were applied (Fig. 6). After a definite period, *constant* deformation rates were reached in every case. Because only these constant rates are of interest in this paper, the time segments were not considered between the introduction of the weight and until several retardation times had passed. The average rate magnitude was calculated by the method of least squares.

IV. 2. *Viscosity as a function of the first and second basic invariants.* In application of the theory stated in the section II, analyses was begun with the uniaxial state of deformation (Figs. 7 and 10). Here are found all of the measured values in the plain  $\mathcal{V}_{(2)}=0$  (see Fig. 1). As good as possible fitted curves for  $F_s=1$  have been plotted conformable to eq. (27). The experiment results of the uniaxial state of stress were thereon divided into classes with approximately equal values of  $\mathcal{V}_{(1)}$ . For an average value of the corresponding classes, the viscosities in the plain  $\mathcal{V}_{(2)}=0$  were read (see Figs. 7 and 10), and from these points the theoretical curves in Figs. 8, 9 and 11 calculated. From this proceeding, the constants of the continuum are given in Table 2.

Table 2

Experiment	$\mu_0$ [dyne·sec·cm <sup>-2</sup> ]	$\beta'$ [sec]	$\alpha'$ [sec]		
66.002 .003 .004	54 · 10 <sup>10</sup>	8.65 · 10 <sup>6</sup>	0.57	1.41	0.0 · 10 <sup>6</sup>
66.011	176 · 10 <sup>10</sup>	8.90 · 10 <sup>6</sup>	28.6	14.2	17.3 · 10 <sup>6</sup>
66.012 .013 .015	365 · 10 <sup>10</sup>	27.00 · 10 <sup>6</sup>	40.1	27.4	20.2 · 10 <sup>6</sup>

The calculated values of  $\alpha'$  for the various average  $\mathcal{V}_{(1)}$  are relatively widely scattered. This is however not surprising; a relative wide range for  $\mathcal{V}_{(1)}$  was chosen.

IV. 3. *The bulk viscosity as a function of the first basic invariant.* In Figs. 12 and 13, the *reciprocal* value of the bulk viscosity was plotted for expediency. The obtained constants from the adjusted theoretical curves can be seen in Table 3.

With the tensile tests, the bulk viscosity always became infinitely large after a definite time, even with small stress values. Such a phenomenon was not theoretically predictable. It seems therefore that snow, as already recognized by Haefeli (1939, 1942), resists a volume enlargement.

IV. 4. *Influence of time.* In the preceding experiments, a very surprising type and manner of time influence was recognized, especially with the bulk viscosity as a function

Table 3

Experiment	$\mu_{v0}$ [dyne·sec·cm <sup>-2</sup> ]	$\beta'$ [sec]
66.002 66.003 66.004	200 · 10 <sup>10</sup>	105.9 · 10 <sup>6</sup>
66.011 66.012 66.013 66.015	666 · 10 <sup>10</sup>	137.2 · 10 <sup>6</sup>

of the first basic invariant: almost independent from the weighting process (Fig. 6), the points move more or less along the calculated curves with the passage of time in the direction of the point of infinitely large bulk viscosity. The difference between the tensile and compression experiments was that with the latter, the beginning occurred by a smaller bulk viscosity and subsequently an infinitely large bulk viscosity was never reached.

The same effect can also be observed with the shear viscosity, although not so distinctly.

In the last phase with small rates of deformation, the long-lasting trial 66.012 exhibited no significant increase in the magnitude of the viscosities.

On the other hand however, it is interesting to note that the viscosities also increased

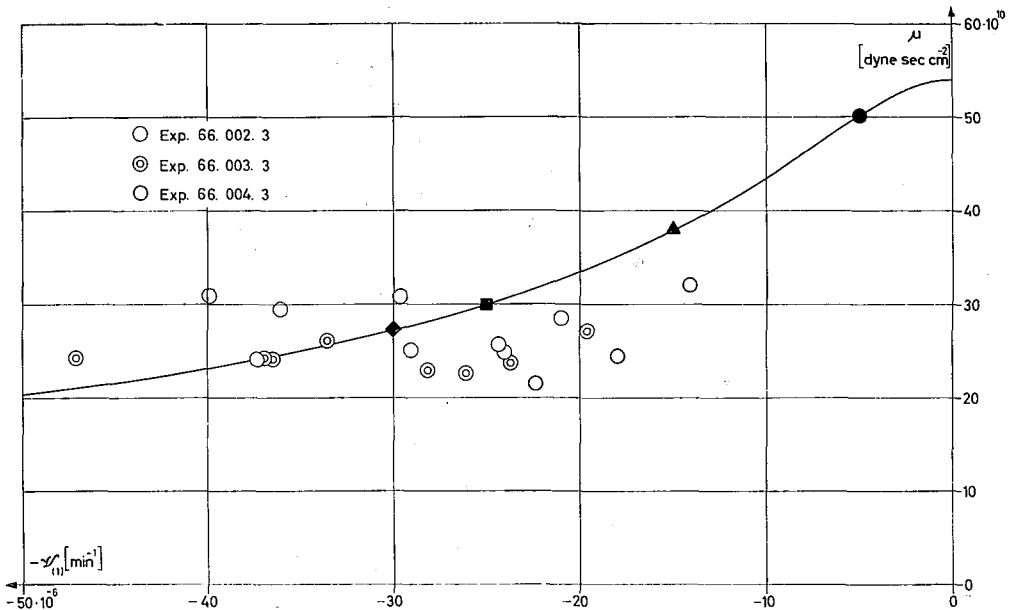

Fig. 7. Viscosity as a function of the first basic invariant with vanishing second basic invariant

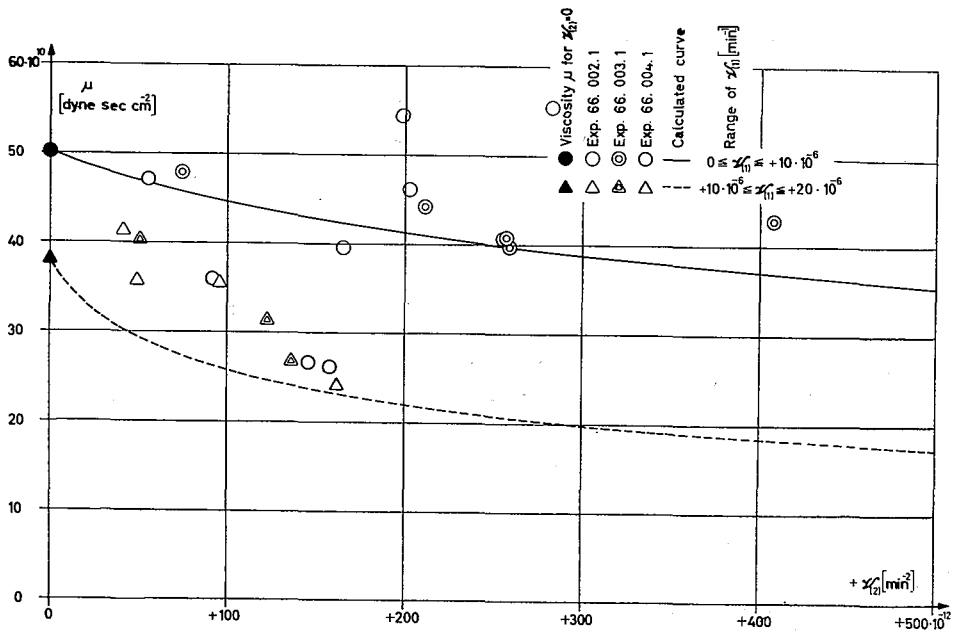

Fig. 8. Viscosity as a function of the second basic invariant (uniaxial state of tensile stress)

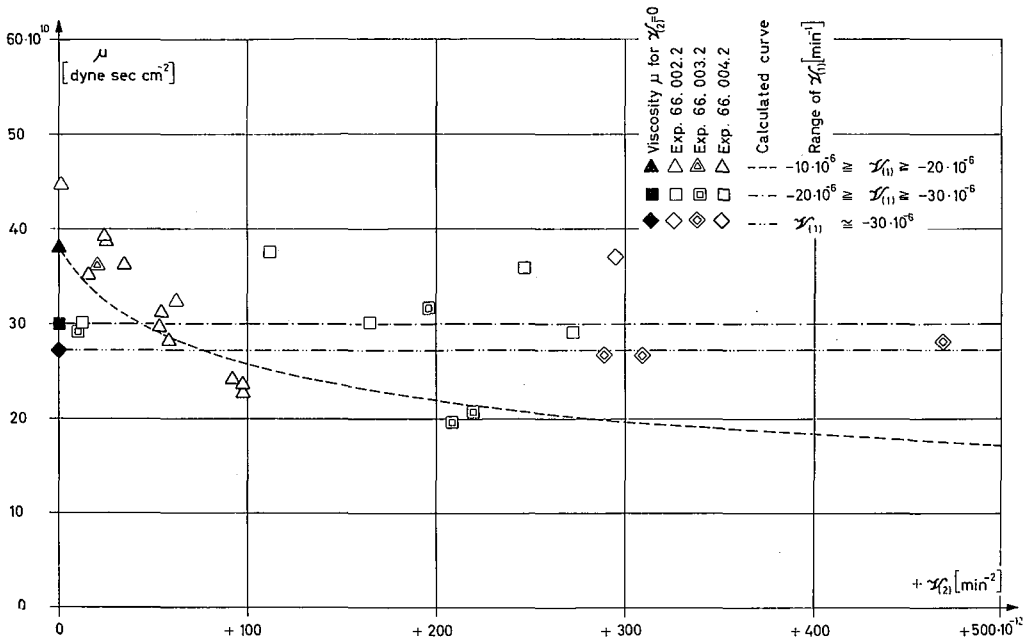

Fig. 9. Viscosity as a function of the second basic invariant (uniaxial compressive state of stress)

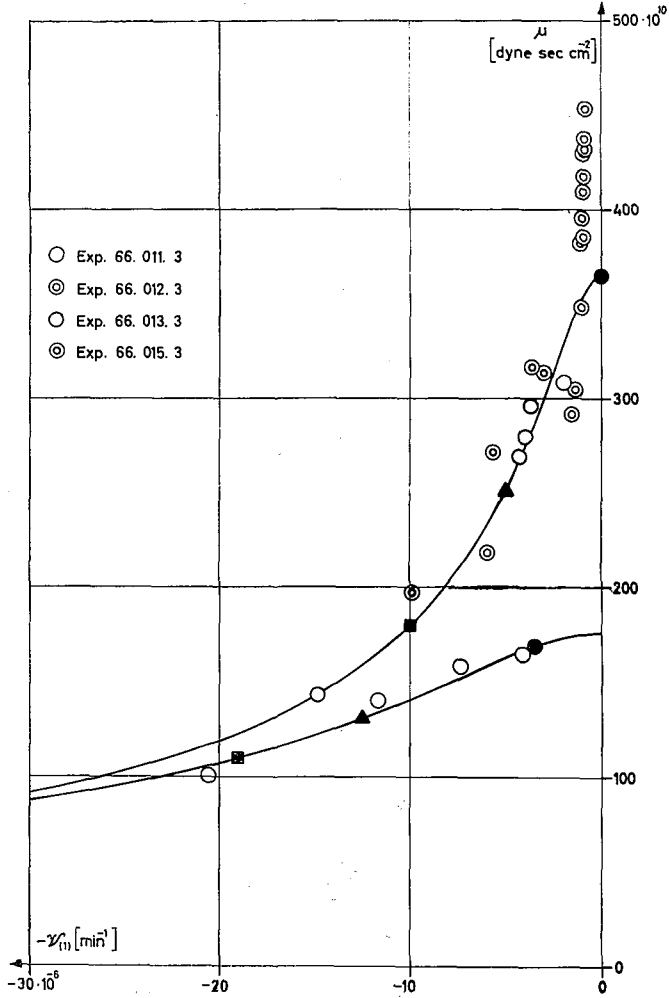

Fig. 10. Viscosity as a function of the first basic invariant with vanishing second basic invariant

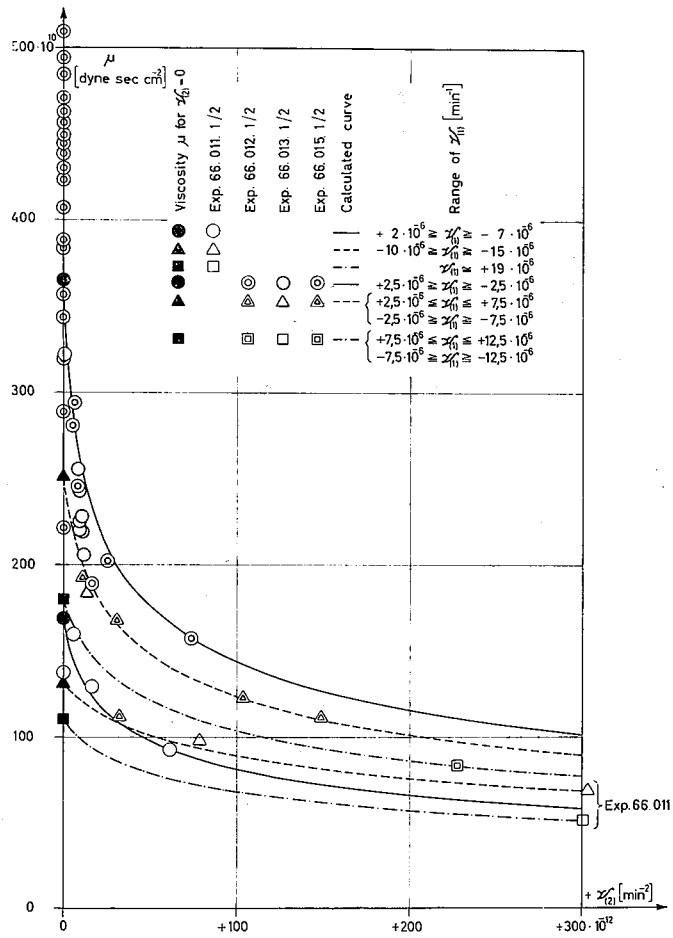

Fig. 11. Viscosity as a function of the second basic invariant (uniaxial tensile and compressive states of stress)

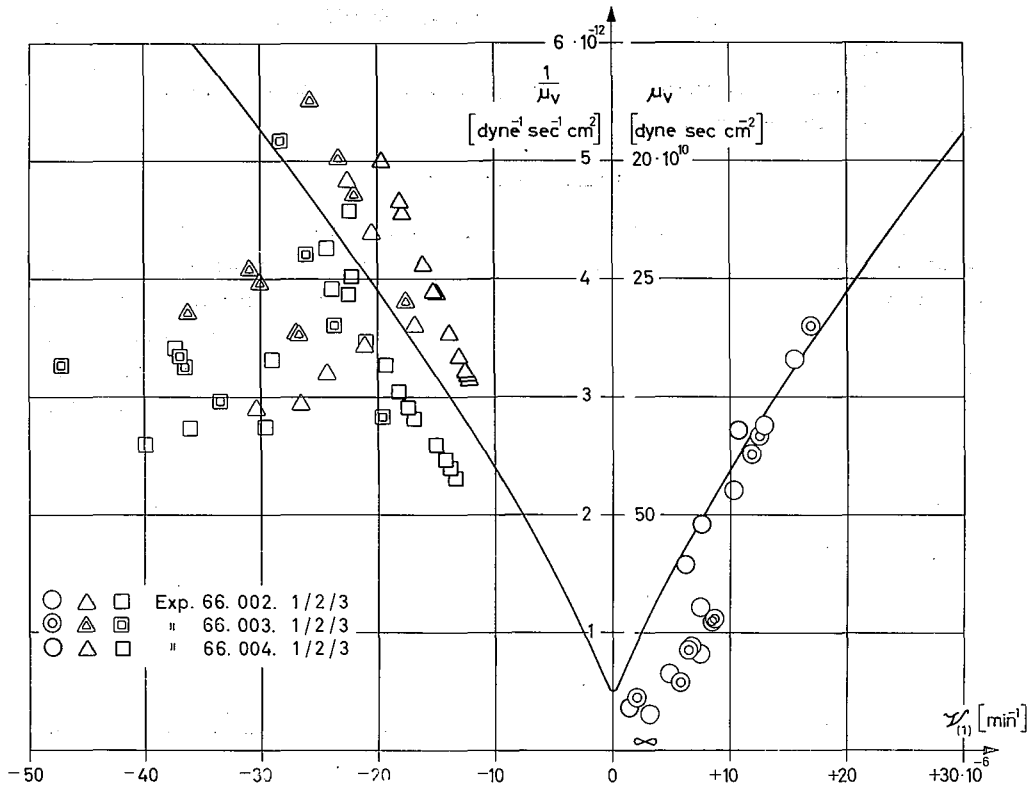

Fig. 12. Reciprocal value of the bulk viscosity as a function of the first basic invariant

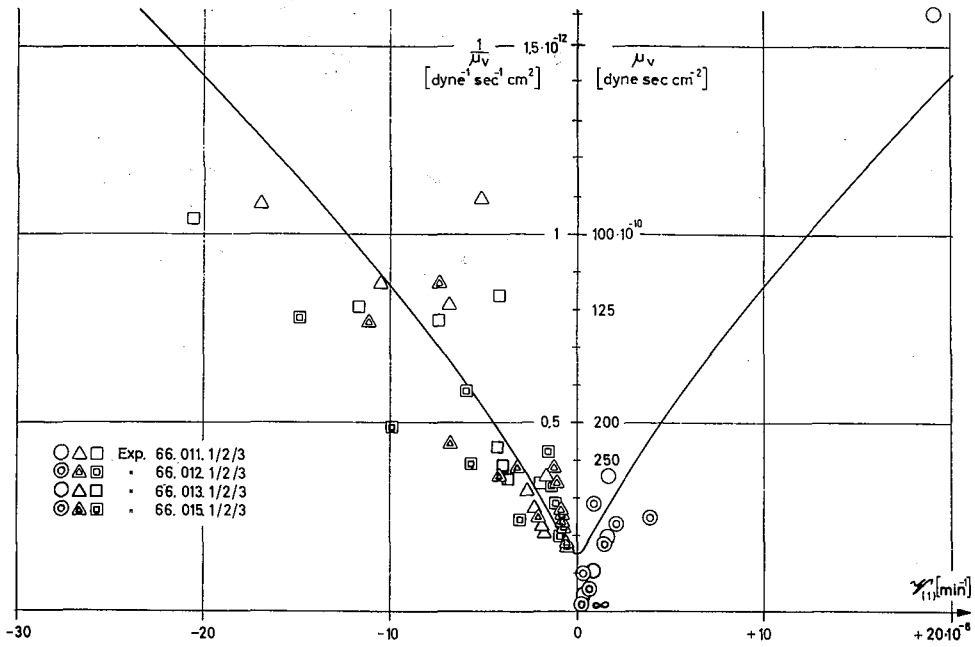

Fig. 13. Reciprocal value of the bulk viscosity as a function of the first basic invariant

during the weighting-free periods of trials 66.002 and 66.003. This was also observed by Yosida (1956).

For the present, it is therefore not established if the constants  $\mu_0$ ,  $\mu_{v0}$ ,  $\alpha'$  and  $\beta'$  are truly invariants relative to time.

### Acknowledgments

The author would like to thank Dr. M. de Quervain, Director SLF, for his support of the proceeding work. Dr. Th. Zingg is due thanks for his worthwhile suggestions in connection with snow sample choice. Mr. H. Hügi built the apparatus to perfection and decidedly assisted with the inconvenient experiments as well as the analysis. Mr. G. Klausegger is to be thanked for his help with the compilation of the experimental results. I would like to thank Mr. W. G. Weinel, U. S. Forest Service, for his translation into English.

Many thanks are owed the Nippon Kokan Kabushiki Kaisha, which enabled the author to take part in the conference. Also to be greatly thanked is the Japanese Society of Snow and Ice for the official invitation to visit Japan. It is my wish to give my sincere thanks to Dr. M. Shoda for his great efforts on my part. This same thanks is owed to Mr. H. Nakajima.

### References

- 1) BUCHER, E. 1948 Beitrag zu den theoretischen Grundlagen des Lawinenverbaus. Beiträge zur Geologie der Schweiz—Geotechnische Serie—Hydrologie, Lieferung 6, 21-26.
- 2) HAEFELI, R. *et al.* 1939 Der Schnee und seine Metamorphose. Beiträge zur Geologie der Schweiz—Geotechnische Serie—Hydrologie, Lieferung 3, 69-241.
- 3) HAEFELI, R. 1942 Spannungs- und Plastizitätserscheinungen der Schneedecke. Mitteilungen aus der Versuchsanstalt für Wasserbau an der ETH, Nr. 2, 1-46.
- 4) KAUZMANN, W. 1941 Flow of solid metals from the standpoint of the chemical-rate theory. *Trans. Amer. Inst. Mining and Metal. Engineers*, 143, 57-83.
- 5) LANDAUER, J. K. 1957 Creep of snow under combined stress. *SIPRE Res. Rept.*, 41, 1-12.
- 6) PRAGER, W. 1961 Einführung in die Kontinuumsmechanik. Birkhäuser Verlag Basel und Stuttgart.
- 7) YOSIDA, Z. *et al.* 1956 Physical studies on deposited snow. II. Mechanical properties (1). *Contr. Inst. Low Temp. Sci.*, 9, 1-81.