



HOKKAIDO UNIVERSITY

Title	Notch-Type Step Construction for Prevention of Avalanches
Author(s)	FURUKAWA, Iwao; 古川, 巖
Description	International Conference on Low Temperature Science. I. Conference on Physics of Snow and Ice, II. Conference on Cryobiology. (August, 14-19, 1966, Sapporo, Japan)
Citation	Physics of Snow and Ice : proceedings, 1(2), 1291-1294
Issue Date	1967
Doc URL	https://hdl.handle.net/2115/20379
Type	departmental bulletin paper
File Information	2_p1291-1294.pdf



Notch-Type Step Construction for Prevention of Avalanches

Iwao FURUKAWA

古川 巖

The Snow Association of Japan, Niigata Japan,

I. Introduction

The mountain area of Tohoku, Shin-etsu and Hokuriku District are under deep snow every winter. The snow cover is 2 to 3 m in depth and slides down along the mountain slope as ground avalanches. In practice, we have cut steps in rows along the contour lines on the slope to prevent avalanche initiation for the past 25 years. These constructions have been practically used in relatively warm weather district where the mean air temperature is about 0°C, and the snow is moistened and wet throughout the winter.

II. Types of Step Construction

We have three types of step construction ; open-cut-type, cut-bank-type and notch-type (Fig. 1). In this paper, only the notch-type cut is to be discussed.

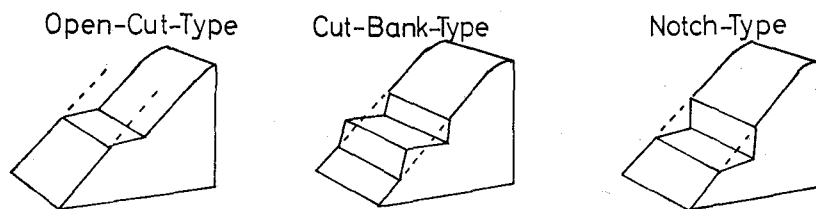

Fig. 1. Three types of step construction

III. Movement of Snow Cover on a Slope with a Notch-Type Step

Movements of snow cover on a slope with a notch-type step are illustrated in Fig 2. In early winter the slope is covered by a snow with an interruption at the wall of

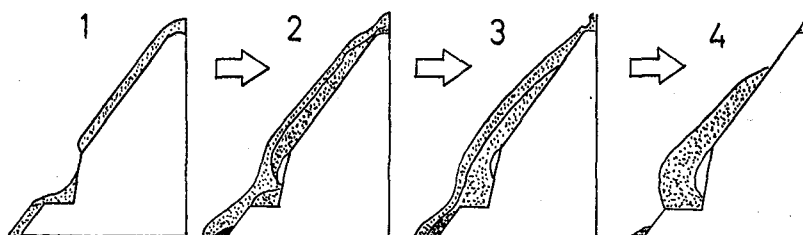

Fig. 2. Movement and deformation of snow on a slope with a notch-type step. 1, initial stage; 2, 2nd stage; 3, snow is moistened; 4, snow is wet and melting

the step. The upper part of the snow slides down along the slope, and when the apex of the snow cover reaches the notch-step, it is entrapped by it. Successive glide motion of the upper part of snow compresses the trapped snow on the step and results in increasing hardness and strength of the snow. From field observations it was confirmed that the compressed snow on the step was sufficiently strong mechanically to hold the snow cover on the upper slope of the step.

IV. Failure Plane of Snow on the Notch-Type Step

A series of experiments were carried out on various kinds of snow covers, to find the failure plane in the compressed snow on the step. Experiments were made by a small scale model (Fig. 3-1), and a failure plane was observed along the plane A-B of Fig. 3-2. However, any failure plane was not seen in the snow cover on the actual step. Contrary to the expectations the snow on the step moved forward in the manner as shown in Fig. 3-3.

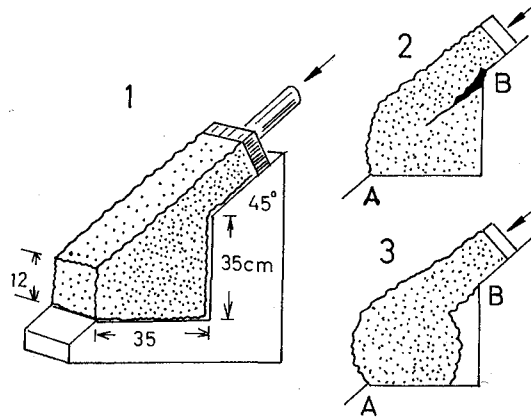

Fig. 3. Experiment of snow fracture and deformation. 1, procedure of the experiment; 2, settled snow and wet granular snow (free water content is 5~10%); 3, settled snow saturated with liquid water

V. Fold of Snow Cover and Density Profile of Snow on the Step

Deformation of a snow cover on a step depends upon the type of deposited snow and the amount of movement of snow cover sliding down the slope. But usually a characteristic folding pattern of snow layers, such as shown in Fig. 4, could be observed in the snow on the step. A lesser movement of a snow cover showed a lesser fold of snow layer on the step. Along the plane AB of Fig. 4, wet snow settled and the densities ranged between 0.5 and 0.6 g/cm³.

Notch-Type Step Construction for Prevention of Avalanches

Iwao FURUKAWA

古川 巖

The Snow Association of Japan, Niigata Japan

I. Introduction

The mountain area of Tohoku, Shin-etsu and Hokuriku District are under deep snow every winter. The snow cover is 2 to 3 m in depth and slides down along the mountain slope as ground avalanches. In practice, we have cut steps in rows along the contour lines on the slope to prevent avalanche initiation for the past 25 years. These constructions have been practically used in relatively warm weather district where the mean air temperature is about 0°C, and the snow is moistened and wet throughout the winter.

II. Types of Step Construction

We have three types of step construction; open-cut-type, cut-bank-type and notch-type (Fig. 1). In this paper, only the notch-type cut is to be discussed.

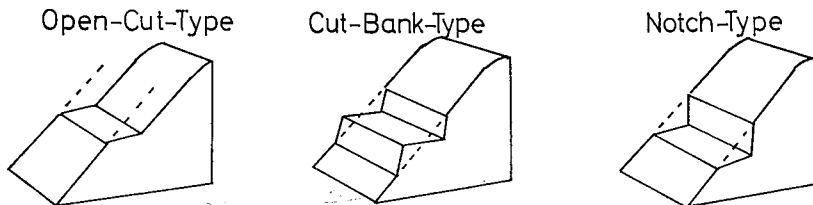

Fig. 1. Three types of step construction

III. Movement of Snow Cover on a Slope with a Notch-Type Step

Movements of snow cover on a slope with a notch-type step are illustrated in Fig 2. In early winter the slope is covered by a snow with an interruption at the wall of

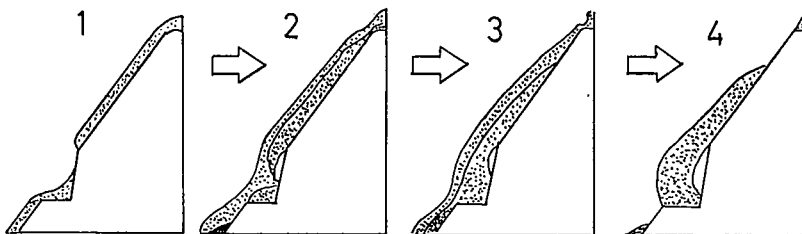

Fig. 2. Movement and deformation of snow on a slope with a notch-type step. 1, initial stage; 2, 2nd stage; 3, snow is moistened; 4, snow is wet and melting

much higher than that of a natural snow cover expressed by the ellipse b in Fig. 5. When melt water soaks the snow and ice formation is resulted under the heavy load, the snow shows a much higher shear strength a , a' of Fig. 5, than that of the natural snow b .

VII. Maximum Horizontal Interval of Notch-Type Steps

The snow cover is mechanically supported on the slope by friction between snow and ground, and by the shear stress across the plane AC in Fig. 4. This consideration gives the maximum horizontal interval D of notch-type steps necessary to suppress the initiation of ground avalanche.

$$D = c \frac{l \cdot K_s \sec \theta}{W_s (\sin \theta - \mu \cos \theta)},$$

where

- θ is declination of the slope, in degrees,
- l width of the step=80% of the maximum snow depth, in meters,
- K_s shear strength of snow across AC plane in Fig. 4, in ton/m²,
- W_s maximum weight of snow on the slope per horizontal unit area, in ton/m²,
- c constant ($c \cdot l \cdot \cos \theta = AC$),
- μ coefficient of static friction of snow with the ground.

In the districts where the snow cover is wet throughout winter, and the depth of it becomes 3~4 m, D is estimated as follows:

$$D = 0.5 \frac{l \cdot K_s \sec \theta}{W_s (\sin \theta - 0.2)}.$$