



# HOKKAIDO UNIVERSITY

Title	Upward Migration of Soil Moisture by Various Mechanisms upon Freezing
Author(s)	Jumikis, A.R.
Description	International Conference on Low Temperature Science. I. Conference on Physics of Snow and Ice, II. Conference on Cryobiology. (August, 14-19, 1966, Sapporo, Japan)
Citation	Physics of Snow and Ice : proceedings, 1(2), 1387-1399
Issue Date	1967
Doc URL	<a href="https://hdl.handle.net/2115/20388">https://hdl.handle.net/2115/20388</a>
Type	departmental bulletin paper
File Information	2_p1387-1399.pdf



# Upward Migration of Soil Moisture by Various Mechanisms upon Freezing

A. R. JUMIKIS

*Department of Civil Engineering, Rutgers-The State University  
New Brunswick, N.J., U.S.A.*

---

## Abstract

As a result of his studies on frost action in soils since 1948, and particularly since 1952, at Rutgers-The State University (of New Jersey), the author has tried to formulate in a conspctive way in this article the principal potentials or mechanisms entering into the soil moisture migration process upon freezing.

It was possible to show schematically at what approximate soil porosity intervals the various kinds of soil moisture transfer mechanisms act.

Also, experiments have been performed by the author, and are still to be performed, in order to establish the actual porosity intervals as well as the corresponding ordinates for the amount of soil moisture transferred upward from the ground-water to the cold front by the various moisture transfer mechanism.

---

## I. Introduction

The paving of the relatively narrow and yet expensive highway and railway ribbon, as well as that of airports, has a comparatively shallow foundation as contrasted with larger and heavier structures, the foundations of which are usually set well below the frost penetration depth. This fact, as well as the fact that they are fully exposed to the weather, makes their pavements especially vulnerable to climatic influences. Earth-work soils in particular are subjected to periodic temperature and moisture variations. For example, frost action may cause differential heaves on roads, but variation in soil moisture content as a consequence of frost action may affect adversely the strength of the soil, particularly during a thawing period after frost has left the ground. This causes loss of bearing capacity of soil and so-called "spring break-ups" on roads built on and of improper soil.

The resulting effect of such conditions usually is damage to roads and their pavements. Thus it can be inferred that frost action imposes difficulties in design, construction, exploitation and maintenance of highways. It also impairs traffic safety. In addition, repairs of roads damaged by frost usually cost huge sums.

Thus, in order to combat frost on highways effectively, it becomes necessary to investigate the various factors contributing to damage to roads by frost. Unfortunately, the interrelationship of the various factors involved in a freezing soil system is very complex indeed, and some of the physical processes which occur in a freezing soil system are not yet well understood, or are even unknown.

The freezing soil system is a complex, multi-component system where heat transfer

is associated with the transfer of soil moisture in a porous medium of soil.

Thus, frost action in highway soils, being a matter of national importance (Jumikis, 1955) constitutes a problem of sufficient weight to merit a separate study.

## II. Assumptions Made in Studies

In order to study physical processes in a freezing soil system, and to obtain a general insight into them, it is necessary, as in almost every, other branch of knowledge, to simplify the actual process considerably, and to focus our attention on the major phenomenon only, *i.e.*, on the process in which we are primarily interested. For these and other reasons, certain assumptions are to be made at the outset of one's studies in order to agree on certain facts.

In making assumptions, let us focus our attention on the interior of the freezing system. Here are some of the assumptions made in the studies of a freezing soil system:

- 1) It is assumed that in the system under consideration there is a groundwater source present at a certain distance below the ground or pavement surface. This assumption corresponds with nature. When there is no water source present, then freezing is a drying process; upon continuous freezing, soil moisture migrates towards the cold front.

- 2) Water is the continuous liquid phase in the porous soil system.

- 3) The frozen ice lenses are connected continuously with the groundwater table by means of soil moisture films which are adsorbed to the surfaces of the soil particles.

- 4) There exists in the water around the solid soil particles an electric diffuse double layer of the Gouy-Chapman or Stern type.

- 5) The surfaces of the solid soil particles are ordinarily charged negatively; the negative ions reside on the surfaces of the particles.

- 6) Upon the application to the soil system of a freezing thermal potential, an upward transport or migration of parts of the soil film-water from groundwater towards the cold front is inaugurated. Of course, it must be kept in mind that this occurs at a proper porosity of the soil. The soil moisture migration takes place by means of various transfer mechanisms when energy is applied to the system (heat is a motive power), and by means of moisture concentration factors.

- 7) For reasons of simplicity, a laminar, unidimensional, upward flow of heat and soil moisture from groundwater to the cold front is assumed. This assumption, because of the film-water flow, is reasonably correct.

- 8) The film moisture and the soil (porous) medium between the groundwater table (entrance into the freezing soil system) at a temperature above freezing and the forming ice lenses, *viz.*, cold front (exit of system) at freezing temperature (dissipation of heat energy) serve as a means of free, laminar communication for the transfer of energy (heat).

- 9) The soil and water are free of electrolytes (particularly when distilled water is used for experiments).

These assumptions for the approximation of the problem oversimplify the actual processes considerably. However, they have the advantage of being explicitly clear, and can be justified as a means of approach to a better understanding of the processes

partaking in the freezing soil system in the field or in a laboratory experiment than would be possible without such assumptions.

### III. Formulation of Upward Soil Moisture Migration upon Freezing by Various Moisture Transfer Mechanisms

*General notes.* Ever since the author has been engaged in frost action research, and particularly since 1952 here at Rutgers University, observations made from our earlier improvised soil freezing experiments indicated that the measured amount of soil moisture transferred from "groundwater" to the soil system upon freezing (=heat potential) was larger than the amounts of water calculated for each single potential, for example, capillarity, vapor or moisture concentration potential.

These observations, as well as studies, led the author to formulate a certain concept about the action of a potential upon the flow of soil moisture in a freezing porous system, such as soil. These studies (Jumikis, 1956) pertain to an open system, soil-moisture-thermal potential, upon freezing, with a groundwater source present.

*Potentials.* In engineering and science, the term "potential" has many meanings. In some branches of science, such as in physics and the engineering sciences, this term, commonly used as an adjective, means "available". Thus one speaks of potential energy or energy of state or position. In contradistinction, in soil science dealing with moisture migration in soil, and in thermal soil mechanics dealing with frost action in soil, the term "potential" is traditionally used as a substantive—for example, thermal potential, capillary potential, electric potential, concentration potential (solvent; moisture potential), gravity potential, and other possible potentials. In this sense, "potential" at a point, or "potential difference" between two points of a freezing soil system would mean the energy, measured by work done, necessary to transfer a unit mass of soil moisture through the porous soil medium from a given position in reference to another particular point within the system, as, for instance, from the groundwater table to the downward penetrating cold front, or any other coordinate point within the system.

*Classification of potentials.* For the purpose of convenience and simplicity, all of the various acting potentials in a freezing soil system may be classed as primary, secondary or tertiary potentials, and then further subdivided into smaller degrees of magnitude and importance as compared with a primary potential.

A primary potential is one applied externally to the system, such as a thermal potential (causing the phenomenon known as thermo-osmosis), an electrical potential (causing the phenomenon known as electro-osmosis), a gravity potential, and other possible potentials.

A secondary potential is one which is induced within the soil system by an externally applied primary potential.

Any primary potential may induce one or several secondary (or tertiary) potentials as new processes and mechanisms for the translocation of soil moisture, such as new heat potentials and electric potentials, for example. A primary thermal potential (=freezing) in a freezing soil system, according to the author's observation in his experimental research, induces an electric potential (or E.M.F.). This is in accord with the electric

diffuse double-layer theory.

*Action of potentials.* A soil moisture transfer is brought about by applying to the soil system a primary thermal potential, *viz.*, a freezing thermal gradient. Further, any primary potential applied externally to a freezing soil-moisture system induces within that system other or secondary potentials which, in their turn, as in a chain reaction, aid, or in some instances counteract, the primary, externally applied potential in moisture transfer. However, it is not well known in which order, sequence, magnitude or intensity the secondary potentials are induced. The existence of the secondarily induced potentials may be the explanation why the measured quantity of moisture transferred in a soil-freezing experiment is larger than the quantities transferred by each potential singly. In other words, the measured quantity of moisture transferred is the sum of the moisture due to both the primary and secondary potentials.

In the case of an externally applied primary thermal potential the author, based on his experimental work, likes to believe that the induced secondary (=electric) potential difference, *viz.*, the induced electromotive force (=E.M.F.), can be measured in the freezing soil system. For further discussion of this point the reader is kindly referred to the latter part of this paper.

By means of the electric diffuse double-layer theory, it is understood that the secondary potential (known also as the streaming potential) in a porous medium is induced by a primary thermal potential upon forcing the soil moisture through the narrow passages of the soil. This occurs when the film-water is in motion, dragging along with it the positive charges (cations) which are dispersed in the film-water. This process of moisture migration is called thermo-osmosis.

It is also known that an electric potential, if applied as a primary potential (electro-osmosis) to a non-freezing soil system, causes moisture in soil to migrate.

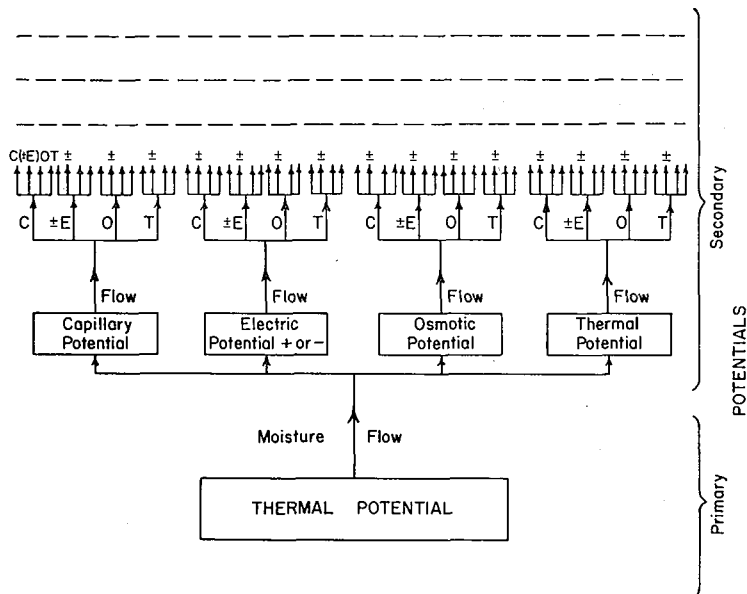

Fig. 1. Primary and secondary potentials schematically shown

It was theorized by the author that this secondary (electric) potential in the thermo-osmotic process induces a flow of moisture in addition to that caused by the primary (thermal), external potential. This flow, in its turn, causes a new potential of a so-called third and smaller order of magnitude, and so on. For example, if the system is more film (unsaturated) than capillary, the primary (thermal potential) would induce a film-water flow, which in its turn would induce a secondary (induced electric) potential. This induced electric (secondary) potential would then induce an additional film-water flow, and so on. It is not, however, quite clear in which direction the induced tertiary flows proceed. This aspect must still be clarified. Therefore, temporarily, in setting up this theory the additional flow effect must be understood as being an *algebraic one*. The idea of the inducement of secondary potentials by a primary potential is shown in Fig. 1 (Jumikis, 1956).

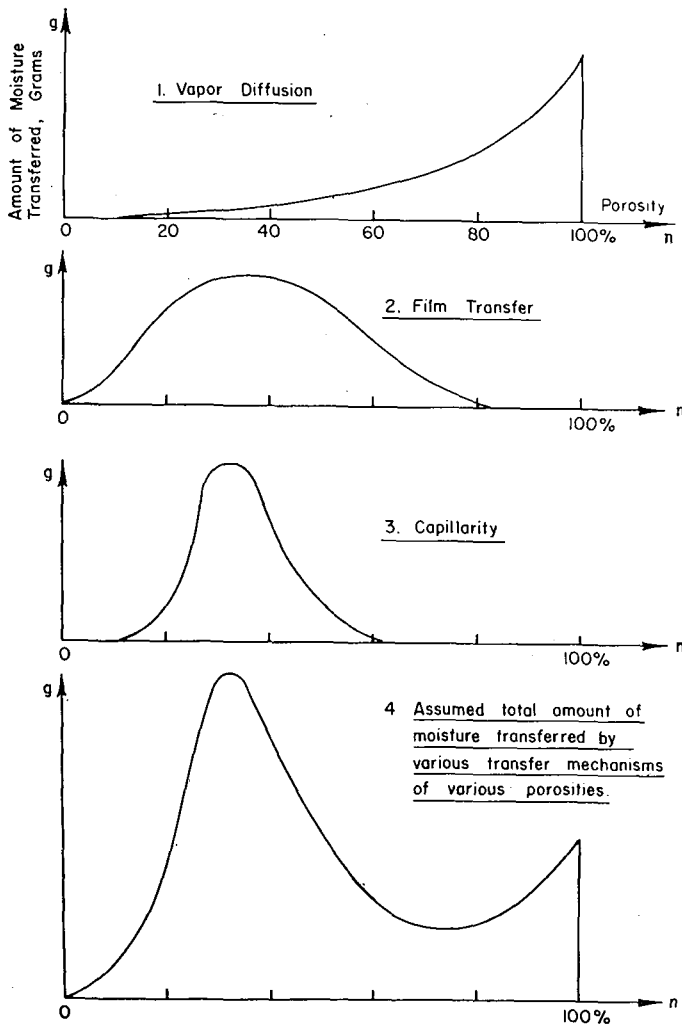

Fig. 2. Various moisture transfer mechanisms and their assumed effects on the amounts of moisture transferred

Of course, in the soil moisture migration process, besides external factors such as the externally applied potentials, there are also internal factors of the freezing soil system, namely: matter (*viz.*, soil type) forming the porous medium, initial soil moisture content, surface forces (zeta or cross-potentials, negative charges—ions—residing on the surfaces of colloidal soil particles), viscosity of bulk water and that of film-water, dielectric constants of soil particles, water and ice, thermal properties of soil, water and ice, electrical conductivity of the electrolyte present, and other possible factors.

*Soil moisture transfer mechanisms.* The manner in which the soil moisture migrates through a porous system such as soil during a freezing process is termed the "mechanism" of moisture transfer.

Upon the application of an external freezing thermal gradient to the soil system and depending upon the degree of porosity of the soil, soil moisture can be transferred by means of the following soil moisture transfer mechanisms (Jumikis, 1956):

- 1) by vapor diffusion,
- 2) in the vapor and film phase,
- 3) in a pronounced film phase,
- 4) in the vapor and capillary phase, and
- 5) in the film-capillary phase.

It is theorized that the acting moisture transfer mechanism, all other conditions being the same, depends upon the degree of porosity of the soil. The various soil moisture transfer mechanisms and their assumed effects on the amount of soil moisture transferred (in grams) by these mechanisms as a function of soil porosity,  $n$ , is qualitatively shown in Fig. 2.

Depending upon the degree of porosity, the soil moisture transferred by one or another mechanism is more accentuated.

Thus, moisture diffusion in the vapor phase would take place in soil with larger void sizes rather than with fine void sizes.

#### IV. Experiments

Because of the many unknown and obscure factors involved in the behavior of a freezing soil system, such systems were studied in their entirety, evaluating their performance by the total end-result of the system, as a whole between the entrance and exit of the system.

*Soil.* The soil type used in these freezing experiments is a frost-prone silty glacial outwash soil, called Dunellen soil. The experimental soil contains

gravel, >1.00 mm	8%
sand, 1 mm-0.05 mm	78%
silt and clay, <0.05 mm	14%

It was used to prepare specimens for a porosity range from  $n=27.8\%$  to  $n=47.8\%$  (tests B-4, B-5, B-6, B-7 and B-9). The size of the cylindrically shaped soil specimens was 15.24 cm in diameter and 30.48 cm high (5 553 cm<sup>3</sup>). This type of soil was used because it is frost-susceptible, and it was readily available in large quantities in the vicinity of the laboratory.

The porosity range from about 50 to 90% was artificially prepared by means of coarse particles (pebbles) of soil placed on supports made of copper wire. The particles for porosity of 60% were not in contact with each other. Hence no film mechanism for the upward moisture transfer was operative; only pure vapor diffusion was possible. The arrangement of pebbles at  $n=90\%$  porosity before freezing is shown in Fig. 3.

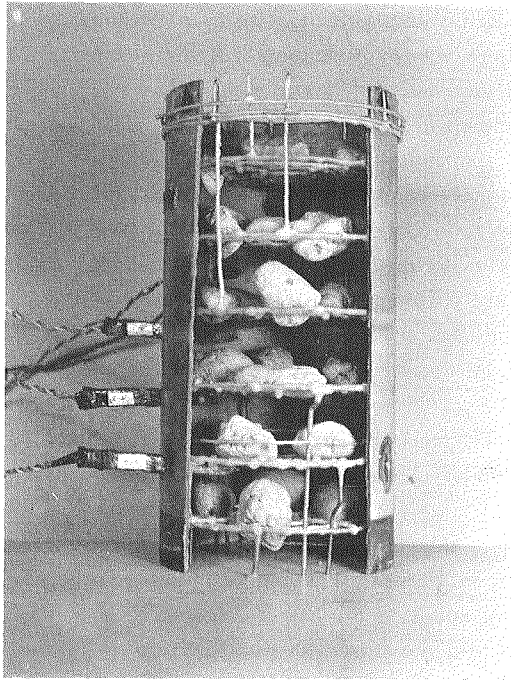

Fig. 3. A packing of  $n=90\%$  porosity before freezing. Experiment A-1

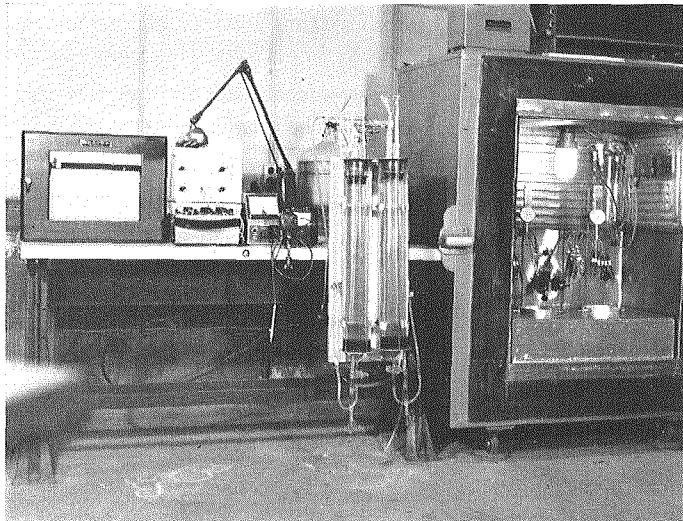

Fig. 4. Soil-freezing equipment

Similar porosity arrangements were made at other large porosities where the particles were not in contact with each other.

*Freezing equipment.* The freezing equipment and instrumentation used in these experiments are the same as described in Reference 4 (Jumikis, 1962). The general view of the author's soil-freezing equipment is shown in Fig. 4.

*Principle of experiments.* The soil-freezing systems were studied as an organic entity, that is, the freezing experiments were so arranged as to simulate nature as closely as possible. There was a provision for groundwater as a source of water supply for the freezing soil system and the laterally insulated soil specimens were frozen from the top down. Also, moisture transfer from places of higher concentration to lower ones upon freezing in the vapor phase, or by film flow, or by a combination of all of these mechanisms, was kept in mind and the experiments were arranged accordingly. The temperature of the groundwater was kept on the average at  $+8^{\circ}\text{C}$ .

*Data recorded.* Immediately after the commencement of freezing, measurements were made of temperature within the soil at various levels, and its environment; driving pressure differences; induced secondary electrical potential differences; the supply of groundwater consumed by the freezing soil system from a burette during freezing, and frost heave.

The duration of each freezing experiment was 168 hours (=7 days). All experiments were performed under identical laboratory conditions, thus facilitating comparison of experimental data.

*Experimental results.* The results of the experimental study on freezing of the Dunellen soil are shown in Fig. 5. The plots of data permit one to evaluate the overall effects in the freezing soil system. From this figure the following can be seen.

- 1) The quantity of soil moisture transferred from groundwater to the cold front upon freezing as a consequence of an externally applied freezing temperature gradient to the soil system is a function of porosity of the soil.

- 2) Depending upon the magnitude of the porosity of the soil moisture may be transferred upward from groundwater to the cold front by way of various moisture transfer mechanisms.

- 3) The effective soil moisture transfer mechanism is by way of the film flow (unsaturated flow) within the porosity range between about  $n=27.8\%$  and  $n=47.8\%$  (soil particles in contact).

- 4) Between porosities of about  $n=60\%$  and  $n=100\%$  vapor transfer is a relatively ineffective soil moisture transfer mechanism; that is, soil moisture transfer in the film phase takes place virtually unaccompanied by vapor diffusion. Here  $n=100\%$  means an empty cylinder.

- 5) The Dunellen soil used in these experiments attains its maximum moisture consumption at about 42% porosity.

- 6) The soil moisture transfer graph also indicates that the amounts transferred in the film phase (up to approximately  $n=47.8\%$  porosity) are about five times greater than by way of pure vapor diffusion ( $n=60\%$  to  $n=100\%$ ).

- 7) The E.M.F. values reported here in millivolts appear to reflect the shape of the parent soil moisture transfer curve.

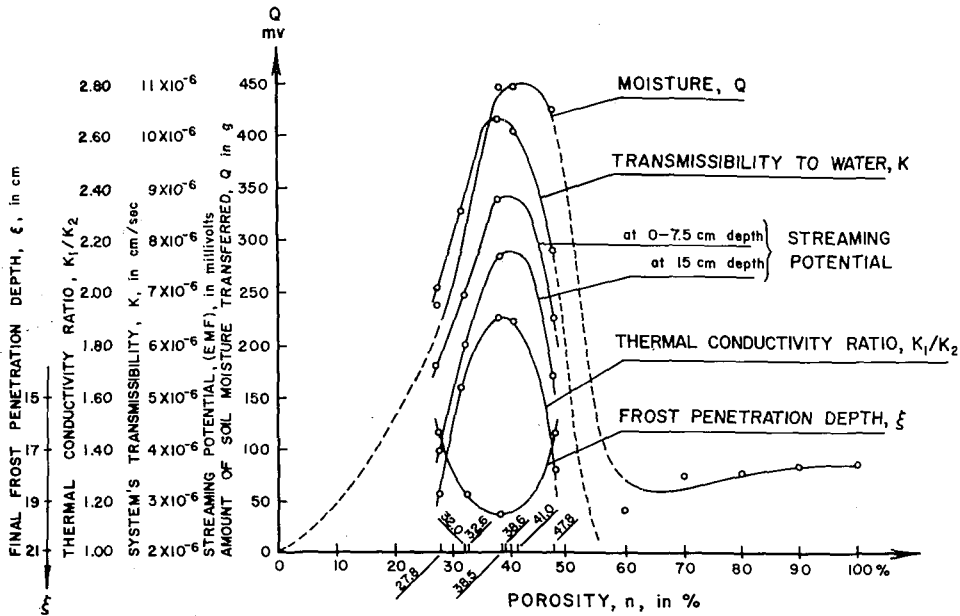

TEST NUMBERS			B-6	B-2	B-5(3)	B-4	A-18	B-7	B-5	A-6	A-5	A-3	A-4	A-7
EFFECTIVE SOIL MOISTURE TRANSFER MECHANISMS			LOWER POROSITIES THAN n=27.8% ARE DIFFICULT TO ATTAIN IN PRACTICE			EFFECTIVE MOISTURE FILM FLOW			FILM AND VAPOR FLOW	PURE VAPOR TRANSFER				
POROSITY, n, %			27.8	32.0	32.6	38.5	38.6	41.0	47.8	60.0	70.0	80.0	90.0	100.0
VOID RATIO, e			0.385	0.470	0.484	0.626	0.628	0.695	0.916	1.500	2.333	4.000	9.000	∞
OPTIMUM MOISTURE CONTENT, w, %			12.6	11.1	11.4	13.8	12.8	12.8	12.4	—	—	—	—	—
MAXIMUM DRY DENSITY lb/ft <sup>3</sup>			119.8	111.1	102.1	97.7	86.7	66.2	46.7	35.1	16.5	0.0	0.0	0.0
AMOUNT OF SOIL MOISTURE TRANSFERRED	ABSOLUTE AMOUNT, Q, in grams		239.0	250	438	445	424	41.9	77.0	77.8	87.8	91.6	—	
	RELATIVE TO MOISTURE TRANSFERRED AT n=100% POROSITY		2.61	2.73	2.78	4.28	4.87	4.63	0.46	0.84	0.85	0.98	1.00	—
SYSTEMS TRANSMISSIBILITY, K, cm/sec		K <sub>2</sub> for unfrozen soil	7.17 × 10 <sup>-6</sup>	8.34 × 10 <sup>-6</sup>	10.35 × 10 <sup>-6</sup>	9.95 × 10 <sup>-6</sup>	7.95 × 10 <sup>-6</sup>	—	—	—	—	—	—	—
STREAMING POTENTIAL { 0-7.5 cm } { 15.0 cm } mv			100	200	250	340	—	170	275	—	—	—	—	—
THERMAL CONDUCTIVITY RATIO K <sub>1</sub> /K <sub>2</sub>			1.29	1.65	—	1.91	1.90	1.33	—	—	—	—	—	—
FINAL FROST PENETRATION DEPTH, ξ, in inches			16.5	18.8	19.6	—	16.5	—	—	—	—	—	—	—

Fig. 5. Amount of soil moisture transferred upon freezing as a function of porosity of soil

8) The maximum magnitude of developed streaming potential in the freezing soil system studied, as seen in Fig. 5, can be scaled off as being 350 mv at about  $n=41\%$  porosity.

9) The frost penetration depth curve as a function of porosity,  $n$ , justifies the following statements: the maximum frost penetration depth occurs at the same porosity as the porosity at which the maximum amount of soil moisture is transferred and the maximum magnitude of induced streaming potential occurs. There appears to be no time lag between these three phenomena.

10) The coexistence of both the vapor transfer mechanism and the film mechanism does not necessarily give rise to greater moisture transfer. Apparently the size of the voids is not large enough to permit effective vapor transfer, and at the same time too large to permit effective film-water transfer (see Fig. 5).

Figure 6 shows a photograph of the B-9 specimen after freezing. Here the cardboard cylinder has been cut away to reveal the zone of ice layers in the zone of the frost boundary.

Figure 7 shows ice layers of test specimen A-22. Below the ice layers, note the unfrozen part of the soil. The frost boundary penetrated to a depth of about 70 to 80% of the total height of the cylindrically shaped soil specimen.

The process of ice banding is described in the author's book *Thermal Soil Mechanics* (Jumikis, 1966).

Figures 8 and 9 show ice (snow) formation within the experimental cylinder as a result of vapor diffusion upon freezing at a porosity of  $n=100\%$ . Note the very porous structure of the ice.

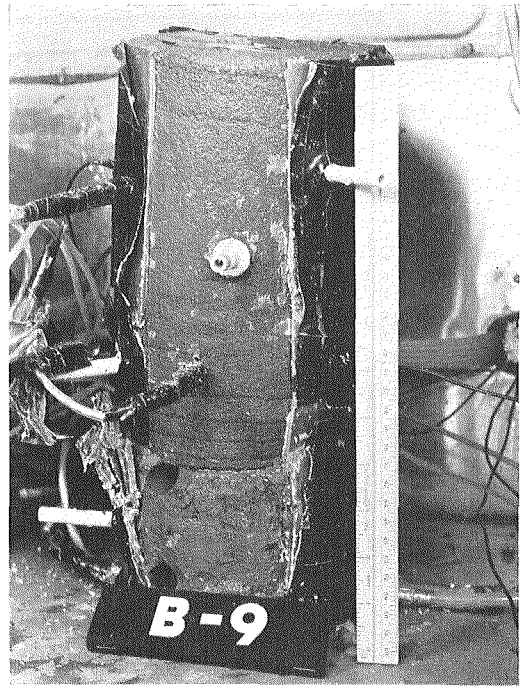

Fig. 6. Ice layers. Experiment B-9

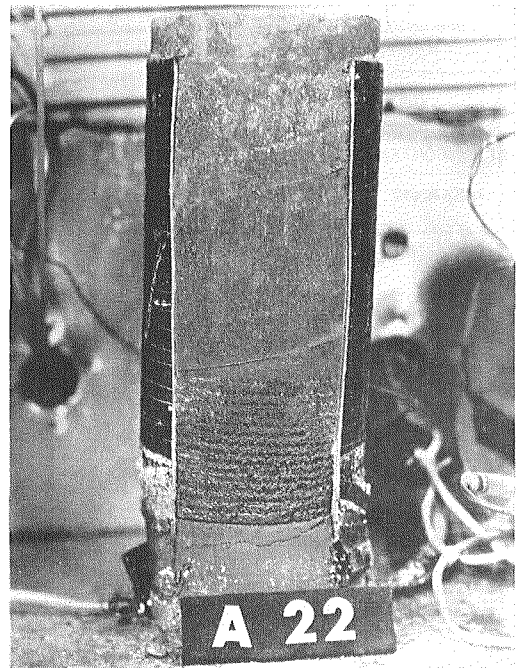

Fig. 7. Ice layers and frost heave. Experiment A-22

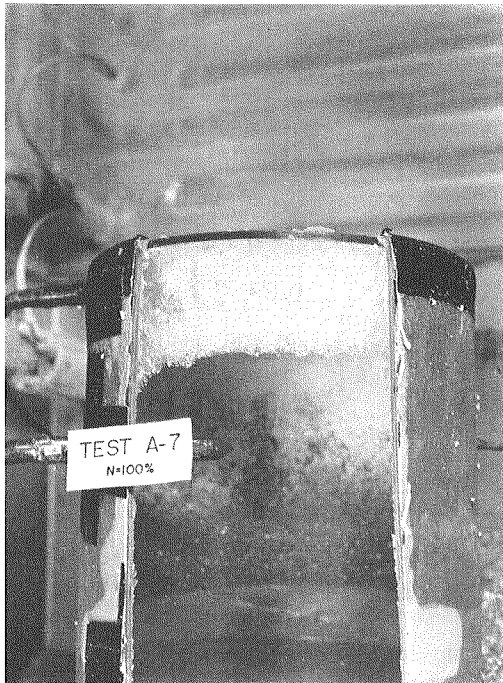

Fig. 8. Formation of porous ice structure below the frozen surface

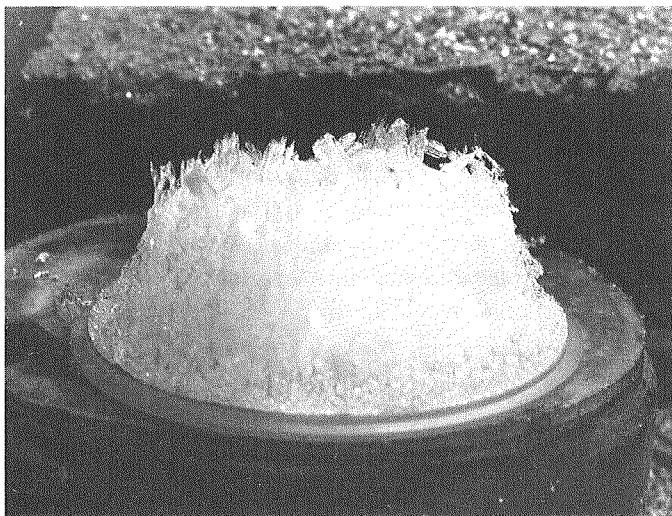

Fig. 9. Nature of the ice crystals formed on the underside of the plexiglas cover

## V. Discussion and Conclusion

The hypothesis outlined herein served the author as a program on which his experimental frost action research in soils was based.

The measurements made in the author's studies comprehend the total effects of soil moisture transfer caused by all possibly acting potentials. This corresponds to the natural processes as they occur in the field under freezing conditions: the freezing thermal gradient (externally applied to the soil system) induces within the soil during the freezing process an upward flow of moisture, and secondary and tertiary potentials. Thus the freezing soil system is studied in its entirety, evaluating the performance of the freezing soil system by its total net end result.

Because it is extremely difficult to separate induced potentials, the measurement of the total effect by means of the hydrodynamic theory (suction pressure theory) and thermodynamic theory can be considered as being equivalent to the actual processes as they occur within a freezing system in the field.

The discussion in this article on the theory of a possible effective mechanism for the soil moisture translocation upon freezing shows that the property of a colloidal soil particle of carrying on its surfaces an electrical charge, and the functioning of soil moisture films surrounding the soil particles as an electrolyte, are of basic significance in the process of the translocation of soil moisture in the film phase set in motion by an external, primary, thermal potential—freezing.

Soil freezing experiments have shown that upon freezing and at the proper porosity soil water is transferred from groundwater via the soil moisture films to the cold front. The mobile part of the moisture film is set in motion tangentially past the immobile part of the film by a subfreezing temperature gradient. The translocating film moisture, displacing (dragging) the positive ions of the water molecules, induces an electric (secondary) potential along the cylindrical-columnar system of soil.

In order to learn the significance and the effect of vapor pressure and vapor diffusion in the soil freezing process, and in order to examine the validity of the assumption that the upward flow of soil moisture upon freezing is virtually unaccompanied by vapor diffusion, this assumption was first studied theoretically (Jumikis, 1955), using assumed values for physical constants, and then experimentally (Jumikis, 1956). The theoretical and experimental studies bring out the relatively small order of magnitude of the pressure difference when operating with such assumed values, which from experience indicate that they are optimum, reflecting pretty nearly the actual or real conditions.

Upward vapor transfer in soil of medium density upon freezing can therefore be considered as an ineffective mechanism of moisture transport. In other words, moisture diffusion in the vapor phase would take place in soil with large void sizes rather than with fine void sizes.

It seems now that the unknown and obscured factors and their associated processes in a freezing soil, which are of intricate nature, outnumber the known ones. And this, in its turn, challenges our studies and justifies our efforts in pursuing frost action research in soils to learn as much as possible about all the factors and processes involved, and to understand more fully the freezing phenomena as a whole.

All in all, these studies, which pertain to unsaturated as well as saturated flow, permitted

- 1) the formulation of various soil moisture transfer mechanisms, and verification of the intervals of their existence as a function of soil porosity;
- 2) the establishment of the concept of a *soil freezing system* theoretically and experimentally as a thermal system, thus strengthening the subject of thermal soil mechanics.

The author makes no claim that these experimental studies exhaust all the possible experimental tools and knowledge for studying some aspects of a freezing soil system. It is hoped, however, that the results of these studies may be of interest to highway, foundation, earthwork and soil engineers.

### Acknowledgments

This paper concerns

1) an initial phase of the research project "Upward Migration of Soil Moisture Under Freezing Conditions", sponsored for the author by the National Science Foundation Grant NSF-G 1968 from 1955 to 1958,

2) a continuation phase of the research project "Upward Migration of Water in Soil Exposed to a Freezing Atmosphere", sponsored for the author by the National Science Foundation Grant NSF-G 6577, from 1958 to 1961/62, and

3) a phase of the author's unsponsored research as his own academic activity since 1961/62 to date, after the termination of the National Science Foundation Grants in 1961/62.

Sincere appreciation is here expressed to Dr. E. C. Easton, Dean, College of Engineering; Dr. M. L. Granstrom, Chairman, Department of Civil Engineering, and Dr. R. C. Ahlert, Executive Director, Bureau of Engineering Research, College of Engineering, all of Rutgers The State University, for their hearty support in providing means for the preparation of this paper for publication.

### References

- 1) JUMIKIS, A. R. 1955 *The Frost Penetration Problem in Highway Engineering*, Rutgers University Press, New Brunswick, New Jersey, 162 pp.
- 2) JUMIKIS, A. R. 1956 *The soil freezing experiment*. In *Factors Influencing Ground Freezing*. *Highway Res. Board Bull.*, **135**, 150-165.
- 3) JUMIKIS, A. R. 1956 *Formulation of upward moisture transfer upon freezing by various moisture transfer mechanisms*. In *Frost Action Research Memorandum, 1948-1956*. Submitted to the Engineering Research Advisory Committee at Rutgers The State University, College of Engineering, New Brunswick, New Jersey, 9 pp.
- 4) JUMIKIS, A. R. 1962 *Experimental study on soil moisture transfer in the film phase upon freezing*. In *Soil Behavior Associated with Freezing*. *Highway Res. Board Bull.*, **331**, 21-27.
- 5) JUMIKIS, A. R. 1966 *Thermal Soil Mechanics*, Rutgers University Press, New Brunswick, New Jersey, 267 pp.