



# HOKKAIDO UNIVERSITY

Title	Frost Hardening of Woody Plants at Temperatures below Zero
Author(s)	Krasavtsev, O.A.
Description	International Conference on Low Temperature Science. I. Conference on Physics of Snow and Ice, II. Conference on Cryobiology. (August, 14-19, 1966, Sapporo, Japan)
Citation	Cellular Injury and Resistance in Freezing Organisms : proceedings, 2, 131-141
Issue Date	1967
Doc URL	<a href="https://hdl.handle.net/2115/20413">https://hdl.handle.net/2115/20413</a>
Type	departmental bulletin paper
File Information	1_p131-141.pdf



# Frost Hardening of Woody Plants at Temperatures below Zero

O. A. KRASAVTSEV

O. A. Красавцев

*K. A. Timiriasev Institute of Plant Physiology  
Academy of Sciences of the USSR, Moscow, USSR*

---

## Abstract

A remarkable increase in frost hardiness of woody plants occurs after subjecting them to subzero temperatures. In the course of slow step freezing water is crystallized in intercellular spaces of the plant tissue. The amount of ice in plant tissues increases with the decrease in temperature down to  $-60^{\circ}\text{C}$  and the cells are gradually dehydrated. It is suggested that in this way a new order of submicroscopic protoplasmic structure is produced which brings about some new properties of the cells. Unfrozen water in the hardened cell is easily transformed into a vitreous state at super-low temperatures. Dehydration resistance also increases in the cell. The hardened twigs of some species survive severe desiccation at low temperatures.

---

## Introduction

The increase in frost hardiness of woody plants after entering dormancy occurs at low temperatures above zero. Tumanov (1940) called this process the first stage of hardening. After hardening at low temperatures above zero under natural conditions in late autumn, Central Russian varieties of cherry trees and apple trees are capable of enduring temperatures down to  $-10$  or  $-20^{\circ}\text{C}$  and many forest plants are known to endure temperatures down to  $-20$  or  $-30^{\circ}\text{C}$ . At a definite negative temperature range northern woody plants can increase their frost resistance (Tumanov and Krasavtsev, 1959; Krasavtsev, 1960). This process was called the second stage of hardening by Tumanov. Many woody plants can withstand freezing down to  $-70^{\circ}\text{C}$  and even to extremely low temperatures as a result of the second hardening.

The frost hardening process of various forest and fruit plants was studied under controlled conditions at the Artificial Climate Laboratories in the K. A. Timiriasev Institute of Plant Physiology in the outskirts of Moscow. The purpose of the present investigation was to find out 1) temperature conditions which are required for an increase in frost hardiness; 2) what changes occur in plant tissues at temperatures below zero.

### I. Temperature Conditions and Length of Frost Hardening

It is found that in late autumn firstly a long exposure to slight frost at  $-5^{\circ}\text{C}$  is effective in increasing frost hardiness of fruit trees. Subjecting the plants to  $-5^{\circ}\text{C}$  and then successively to  $-10^{\circ}\text{C}$  is favourable to increase frost hardiness (Table 1). An increase in frost hardiness of many forest plants also occurs when their twigs are transferred

**Table 1.** Hardening of Antonovka apple trees at temperatures below zero. The degree of frost hardiness is expressed by the minimum temperature at which the twigs survive freezing for 24 hours without injury. Experiments were made in October, 1963

Conditions of hardening	Frost hardiness after cooling at different speeds	
	5°C per hr (°C)	5°C per 24 hrs (°C)
Control (immediate freezing)	-20	-25
at -5° for 5 days	-25	-35
at -5° for 10 days	-25	-40*
at -10° for 5 days	-20	-25
at -10° for 10 days	-25	-25
-5° for 5 days and then -10° for 5 days	-30	-45*
-5° for 10 days and -10° for 10 days	-30	-55*

\* Xylem was damaged

**Table 2.** Hardening of twigs of pine, *Pinus silvestris* L., in strong frost. Before the hardening in strong frost twigs were exposed to (A) -5°C for 7 days; (B) -5°C for 7 days and then -10°C for 7 days. After hardening in strong frost the twigs were transferred immediately to the desired temperatures, at which temperatures the frost hardiness of the twigs was determined. In the control the twigs were transferred immediately from -5 or -10°C to the desired temperatures at which the frost hardiness was determined

Temperature conditions of hardening (for 48 hours) (°C)	Frost hardiness (°C)	
	A	B
Control	-40	-50
-30	-60	-70
-40	-55	-60
-50		-60

immediately from temperatures above zero to -10 or even to -20°C. After long exposure to moderately low temperatures a slight frost hardening proceeds even at -30, -40 and -50°C (Table 2).

The hardening process of various plants proceeds at different speeds. For example, in October birch could withstand -60°C if the temperature had decreased at a rate of

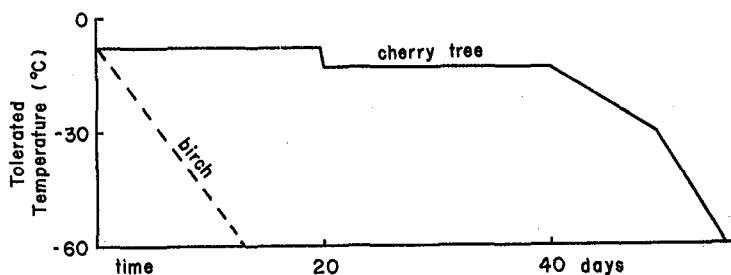

**Fig. 1.** Hardening conditions required for survival of a birch, *Betula verrucosa* Ehrh., and Poliovka cherry tree at -60°C

5°C per 24 hours for 12 days. Poliovka cherry trees also survived  $-60^{\circ}\text{C}$  if they were hardened by slow stepwise cooling for 50 days (Fig. 1). Thus a question arises as to what the fundamental processes of frost hardening in plant tissues are.

## II. Process of Ice Formation

If the decrease in temperature is rapid, ice is formed inside the cells; in this case the plant always dies. When cooling is slow, water is crystallized in intercellular spaces and the cells remain alive (Asahina, 1956). After slow stepwise cooling the hardened plants can survive severe frosts. Therefore, it must be concluded that in such hardened plants ice is produced outside the cells and the cell content is dehydrated. The quantity of ice and unfrozen water in tissues defines the degree of dehydration of cells.

In our previous investigations the amount of ice was determined with an adiabatic calorimeter in rapid thawing of twigs. Further a Calvet calorimeter (Calvet and Prat, 1963) was used in the study of freezing of plants (Fig. 2). A massive metal block with four

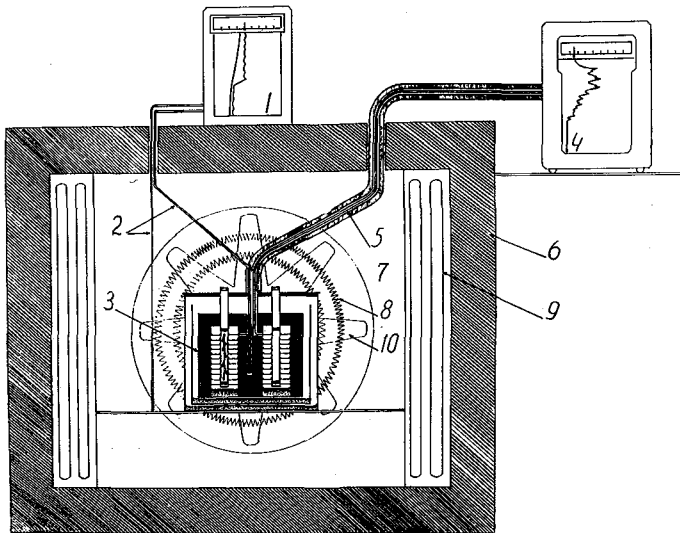

**Fig. 2.** Arrangement for calorimetry at temperatures below zero. 1, 4: Recording instruments; 2: Wires from thermometers; 3: Calvet calorimeter; 5: Wire from thermobatteries of calorimeter cells; 6: Heat insulation; 7: Interior room of frost chamber; 8: Electrical heater; 9: Cooling battery; 10: Fan

differential united calorimeter cells was placed in a freezing chamber. The temperature of the block and heat liberation or uptake in the calorimeter cells were registered with recording instruments. Such an arrangement could be used for the study of freezing and thawing of plants at various rates as well as heat production at constant temperatures below zero.

The results of measurements with the Calvet calorimeter substantiated the previously published data in which the decrease in amount of unfrozen water in plant tissues was related directly to the lowering of temperature (Tumanov and Krasavtsev, 1959). The unfrozen water content was observed to be reduced in a temperature range from 0 to

**Table 3.** Unfrozen water content in twigs of some woody plants (percentage of dry weight)

Species	Temperature (°C)					
	-10	-20	-30	-40	-50	-60
Antonovka apple trees	55	49	39	31	28	23
Lakston black currants	45	33	25	17	11	10
Shirpotreb cherry trees	41	31	25	19	14	—
<i>Betula verrucosa</i> Ehrh.	32	24	16	12	10	8

—60°C (probably, below —60°C also) (Table 3).

The results presented in Table 3 suggest that hardening at negative temperatures ensures the flow to intercellular spaces of almost all of the intracellular water which may freeze at a given temperature. Therefore, hardening at negative temperatures is a gradual dehydration process of the cells. However, this does not explain all changes in properties of cells which may occur as a result of hardening. A comparison of the ice production and hardening rate shows that the latter is more prolonged. The hardening time depends not only on the time required for dehydration of the cell but on definite changes of the properties of the protoplasm which has so far been little known.

During hardening water permeability of protoplasm increases. A comparison of the amount of water which did not freeze in hardened branches with that in previously killed branches showed that the water leaves from the hardened protoplast at almost the same rate as that from the killed branches (Tumanov and Krasavtsev, 1959).

The amount of soluble sugars increases and the amount of starch and hemicellulose decreases in woody plants during hardening at negative temperatures (Pogossian, 1960;



**Fig. 3.** The twigs of birch, *Betula verrucosa* Ehrh., frozen at —10°C and then immersed in liquid nitrogen. Thawing was carried out with different rates: 1 and 2, twigs slowly thawed in air or water at 2°C; 3, twigs rapidly thawed in warm water at 30°C. After rapid thawing the twigs all budded

Ogolevets, 1964; Sakai, 1964). Conversion from starch to sugar is appreciably observed only in slight frosts ( $-5^{\circ}\text{C}$ ), nevertheless hardening proceeds even in strong frosts (up to  $-50^{\circ}\text{C}$ ).

### III. Capacity of Water for Vitrification in the Hardened Cells

Experiments on the cooling of plant to super-low temperatures also show that the properties of the protoplasm change during hardening. Plant tissues are exposed to the largest danger due to the intracellular ice formation at intermediate low temperatures which occur during cooling to super-low temperature. Only for a limited time water may remain uncrystallized at such intermediate temperatures in some solutions (Luyet, 1957).

Thin slices of bark parenchyma of hardened woody plants survived freezing for different times when they had been very rapidly cooled directly from room temperature to various temperatures below zero. The cells survived at  $-50$  or  $-70^{\circ}\text{C}$  for 10-30 minutes but they were killed at  $-30^{\circ}\text{C}$  in a few seconds. Thin slices of many woody plants survived immersion in liquid nitrogen directly from room temperature (vitrification). The slices of bark parenchyma of red-berried elder, *Sambucus racemosa* L., and birch had already acquired a capacity for vitrification at the end of the first hardening stage but those of Streifling apple trees acquired this capacity only after hardening at temperatures below zero (Tumanov and Krasavtsev, 1966).

Even in the case of immersion in liquid nitrogen, whole branches are cooled too slowly, owing to their large size, to survive freezing at super-low temperature if they were not previously frozen. The branches acquire a capacity for vitrification only after their cells were previously desiccated with freezing. The twigs of some woody plants were proved first to survive at super-low temperatures in Sakai's experiments after prefreezing to  $-30^{\circ}\text{C}$  (Sakai, 1956). This was also achieved by greater dehydration of cells by slow stepwise freezing to  $-70^{\circ}\text{C}$  in ours and Parker's previous experiments (Tumanov and Krasavtsev, 1959; Parker, 1960). Later it was found that the hardened twigs acquired a capacity for vitrification after partial dehydration of their cells (Tumanov and Krasavtsev, 1966). The hardened birch twigs frozen to  $-10^{\circ}\text{C}$  can endure immersion in liquid nitrogen if they are rapidly thawed in warm water (Fig. 3). Such prefrozen twigs, however, perished by slow thawing in air after immersion in liquid nitrogen.

It is known that vitrified water can be crystallized during slow warming. On the other hand, rapid warming is also fatal if the cells have been greatly dehydrated with prefreezing. The cause of damage in plants by rapid thawing may be the almost instantaneous absorption of thawed ice water from the intercellular spaces by the dehydrated protoplast, which brings about an irreversible change in the cell (Tumanov and Krasavtsev, 1962). However, slow warming from liquid nitrogen temperature is not injurious if the cells are greatly dehydrated with prefreezing to temperatures below  $-10^{\circ}\text{C}$  (Table 4). Winter wheat could survive at  $-195^{\circ}\text{C}$  under favourable conditions of prefreezing and posterior thawing (Tumanov, Krasavtsev and Trunova, 1965).

It should be noted that some plants (winter wheat, cherry trees) which, after prefreezing at  $-20^{\circ}\text{C}$ , could withstand immersion in liquid nitrogen were injured or killed

**Table 4.** Survival of birch and cherry trees following immersion in liquid nitrogen. The experiments was made in January, 1963

Prefreezing temperature (°C)	<i>Betula verrucosa</i> Ehrh.			Shirpotreb cherry tree				
	Unfrozen water content percentage of dry weight	Thawing cond.			Unfrozen water content percentage of dry weight	Thawing cond.		
		in air	in water			in air	in water	
		2°	5°	30°		2°	5°	30°
-5	48.7	●	●	●	54.2	●	●	●
-10	32.5	●	●	○	41.5	●	●	●
-20	24.8	○	△	△	30.8	●	○	●
-30	16.1	○	△	●	25.4	●	●	●
-40	12.1	○	●	●	19.5	△	●	●

○ : Alive    △ : Injured    ● : Killed

by frost below  $-40^{\circ}\text{C}$ . This suggests that the water which remains unfrozen at  $-20^{\circ}\text{C}$  is freezable at temperatures below  $-20^{\circ}\text{C}$ . Such water remains uncrystallized (vitreous) by rapid cooling to super-low temperatures.

After prefreezing at  $-20^{\circ}\text{C}$  birch shoots are not injured even when they are exposed to low temperatures with various cooling rates. Ice formation cannot occur inside the cells at a given degree of desiccation of cells (about 20–25 per cent unfrozen water of dry weight). But unfrozen water at  $-20^{\circ}\text{C}$  is freezable at temperatures below  $-20^{\circ}\text{C}$ . The amount of ice increases in twigs of birch when the temperature decreases below  $-20^{\circ}\text{C}$  (Table 3).

A direct relation was observed between the degree of the hardening and the amount of unfrozen water which did not impede survival of twigs in liquid nitrogen (Table 5). The more the hardening proceeds in the cells the less the cell dehydration is required for transforming their contents into a vitreous state. Sakai (1963, 1965) reported that the effective prefreezing temperature differed considerably in different degrees of frost hardness in woody plants.

It is conjectured that a definite reorganization of the structure of protoplasm in hardened cells accounts for such a relationship. In well hardened varieties, besides the presence of protective substances and dehydration, another mechanism of frost resistance can be considered which may protect partially dehydrated plants from freezing. Such a

**Table 5.** The relationship between resistance to super-low temperature and degree of frost hardening. Experiments were made in 1962–63

A: The effective prefreezing temperature ( $^{\circ}\text{C}$ )

B: The degree of dehydration at this temperature (unfrozen water content, percentage of dry weight)

Degree of the frost hardening under natural conditions	<i>Betula verrucosa</i> Ehrh.		Shirpotreb cherry tree		Lacston black currants	
	A	B	A	B	A	B
October 8, before frosty weather, following first stage	-50	9.8	The twigs could not withstand super-low temperature		-60	10.4
January 26, after long exposure to frost, second stage	-10	32.5	-20	30.8	-20	32.8

mechanism may be the structural changes in the protoplasm produced during hardening. Changes of the properties of propoplasm may impede intracellular ice formation; The velocity of crystallization of water may be reduced inside the cells; Ice crystals may hardly be formed; They once formed, may grow very slowly in the hardened protoplast. This may explain the survival of hardened plants at extremely low temperatures even when their cells contain a considerable amount of unfrozen water.

#### IV. Hardiness to Desiccation

An interesting property of the hardened cells is their high dehydration resistance. Dehydration of hardened shoots of woody plants is difficult under freezing conditions, because of the many protective covers. Freeze-drying of twigs was achieved by putting them into a special glass vessel (Fig. 4), which was placed in a freezing chamber. Before drying the twigs were slowly frozen. The temperature was lowered at a rate of 5°C per 24 hours. After cooling, drying was carried out in a vacuum of less than  $6 \times 10^{-6}$  mm of mercury at a constant desired low temperature for 3-4 days. The viability of dried twigs was determined after moistening and germination in a green house.

The experiments showed that hardened plants survived in an almost air-dried state

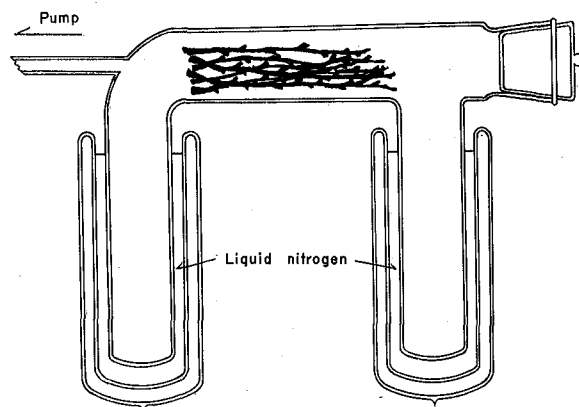

Fig. 4. Device for freeze-drying of twigs of woody plants in hardened state

Table 6. Dehydration resistance of twigs of some woody plants at various low temperatures, as shown by the minimum moisture content at which the twigs survived (percentage of dry weight). Data of winter in 1964-65

Species	Temperature (°C)				
	2	-4	-10	-20	-30
<i>Betula verrucosa</i> Ehrh	17.7	18.0	8.5		
<i>Salix Caprea</i> L.	22.1	16.5	10.4	9.0	
<i>Sambucus racemosa</i> L.	32.0	32.5	30.7	25.5	24.1
Lacston black currants	30.7	31.0	28.1	23.9	24.5
Shirpotreb cherry trees	30.4	29.0	25.1	24.4	22.7
Antonovka apple trees	37.2	36.8	30.5	29.1	25.7

(Krasavtsev, 1967). Birch twigs were viable when only 8.5 per cent moisture remained in their tissues. Such twigs were so brittle that they could be ground to powder. Nevertheless, after moistening they germinated normally. The twigs of the goat willow, *Salix Caprea* L., contained only 9 per cent moisture, after moistening they budded normally and formed roots.

Dehydration resistance of other woody plants was less than that of birch and willow (Table 6). But twigs of all plants survived after removal of 80–85 per cent of the original water content (before drying twigs contained 105–90 per cent moisture of dry weight). It is apparent from Table 3 and Table 6 that the dehydration resistance of frozen twigs is always greater than the degree of dehydration of cells resulting from intercellular ice formation at given low temperatures.

### References

- ASAHINA, E. 1956 The freezing process of plant cell. *Contr. Inst. Low Temp. Sci.*, **10**, 83–126.
- CALVET, E. and PRAT, H. 1963 Microcalorimetry (Russian translation). I. L. Press, Moscow.
- KRASAVTSEV, O. A. 1960 Frost hardening of woody plants. *In Physiology of Hardiness of Plants*, Acad. Sci. Press, Moscow, 229–234.
- KRASAVTSEV, O. A. 1967 Dehydration resistance of hardened woody plants at low temperatures. *Plant Physiol., USSR*, in press.
- LUYET, B. J. 1957 On the growth of ice phase in aqueous colloids. *Proc. Roy. Soc.*, **B 147**, 434–451.
- OGOLEVETS, I. V. 1964 Changes in the carbohydrate content in the bark of trees subjected to low temperatures. *Plant Physiol., USSR*, **11**, 889–896.
- PARKER, J. 1960 Survival of woody plants at extremely low temperature. *Nature*, **187**, 1133–1134.
- POGOSSIAN, K. S. 1960 Carbohydrate metabolism of grape-vine in the hardening process. *Bull. Acad. Sci. Armenian SSR*, **13**, 81–88.
- SAKAI, A. 1956 Survival of plant at super-low temperatures. *Low Temp. Sci.*, **B 14**, 17–23.\*
- SAKAI, A. 1963 Survival of plant at super-low temperatures. III. *Low Temp. Sci.*, **B 21**, 1–16.\*
- SAKAI, A. 1964 The frost hardening process of woody plant. X. *Low Temp. Sci.*, **B 22**, 29–49.\*
- SAKAI, A. 1965 Survival of plant tissue at super-low temperatures. III. *Plant Physiol.*, **40**, 882–887.
- TUMANOV, I. I. 1940 The Physiological Bases of Winter Hardiness in Cultivated Plants. Agricult. Press, Leningrad.
- TUMANOV, I. I. and KRASAVTSEV, O. A. 1959 Hardening of northern woody plants by temperatures below zero. *Plant Physiol., USSR*, **6**, 654–667.
- TUMANOV, I. I. and KRASAVTSEV, O. A. 1962 Effect of thawing rate on survival of vitrified and hardened plants. *Plant Physiol., USSR*, **9**, 595–606.
- TUMANOV, I. I. and KRASAVTSEV, O. A. 1966 Elucidation of the conditions required for vitrification of plant cells. *Plant Physiol., USSR*, **13**, 144–154.
- TUMANOV, I. I. and KRASAVTSEV, O. A. 1966 A study of the mechanism of vitrification of water in plant cell. *Plant Physiol., USSR*, **13**, 487–493.
- TUMANOV, I. I., KRASAVTSEV, O. A. and TRUNOVA, T. I. 1965 Survival of winter wheat –195° in result of vitrification. *Trans. Acad. Sci., USSR*, **161**, 978–981.

\* In Japanese with English summary.

### Discussion on Krasavtsev's Paper

1. According to your results, even at temperatures below –30°C, freezable water in cells

decreases considerably with the decreasing temperature down to around  $-60^{\circ}\text{C}$ . Many investigators have reported that almost all of the freezable water in cells can be withdrawn by extracellular freezing at temperatures around  $-30^{\circ}\text{C}$ . However this discrepancy may be attributable to the difference of methods and instruments used.

Your considerations concerning frost hardening and frost injury at deep temperatures are based on this determination. This may be one of the problems to be solved.

2. Tumanov and his collaborators have reported that two hardening stages are necessary to develop maximum frost hardiness: 1) the first hardening stage at temperatures slightly above  $0^{\circ}\text{C}$ , 2) the second hardening stage under slow cooling for about one month or more at temperatures ranging from  $-5$  to  $-60^{\circ}\text{C}$ . Twigs from willows, white birches, pines wintering in Moscow were artificially hardened by this method and became resistant to freezing at super-low temperatures of  $-196^{\circ}\text{C}$ . However, their experiments have not determined whether the hardening at very low temperatures for long periods of time is really indispensable for keeping these twigs alive following immersion in liquid nitrogen.

In my previous papers (Sakai, 1965, 1966), however, I showed that in late October, one week before defoliation, willow twigs hardened for 14 days at  $-3^{\circ}\text{C}$ , increased their degree of frost resistance from  $-15$  to  $-196^{\circ}\text{C}$ . In addition, when the twigs were hardened at temperatures ranging from  $0$  to  $-30^{\circ}\text{C}$ , the most effective temperature for enhancing frost hardiness was found to be  $-3$  to  $-10^{\circ}\text{C}$ . Below  $-20^{\circ}\text{C}$ , the hardening effect was found to be negligible in any season.

3. As shown in Table 4 and Fig. 3 in your paper, twigs prefrozen at various temperatures from  $-5$  to  $-40^{\circ}\text{C}$  were rapidly immersed in liquid nitrogen and then rapidly rewarmed in water at  $30^{\circ}\text{C}$ . After the treatment, the prefrozen twigs at  $-10^{\circ}\text{C}$  could survive and put forth their buds.

I also made the same experiment with the same idea, with more slender and smaller willow twig pieces (0.3 mm in diameter, 5 cm in length) in winter. Twig pieces immersed in liquid nitrogen following prefreezing at  $-10^{\circ}\text{C}$  were rapidly rewarmed in water at temperatures from  $30$  to  $50^{\circ}\text{C}$ . After the treatment, the cortical cells still remained normal, but the xylem tissues which might be cooled more slowly than the cortical cell were completely damaged. Two weeks later, all twig pieces as a whole were killed. From this fact, it may be impossible to keep twigs alive with ultra-rapid cooling and rewarming method even when partially prefrozen at  $-10^{\circ}\text{C}$ .

A. SAKAI

### References

- SAKAI, A. 1965 Survival of plant tissue at super-low temperatures. III. Relation between effective prefreezing temperatures and the degree of frost hardiness. *Plant Physiol.*, **40**, 882-887.
- SAKAI, A. 1966 Studies of frost hardiness in woody plants. II. Effect of temperature on hardening. *Plant Physiol.*, **41**, 353-359.

1. I determined that the amount of unfrozen water in plant tissue decreased with the decreasing temperature down to  $-60^{\circ}\text{C}$ . My results are in accordance with some data (Greathouse, 1935; Stark, 1936). But some investigators (Wood and Rosenberg, 1957;

Scholander *et al.*, 1953; Tranquillini and Holzer, 1958) determined that almost all freezable water is withdrawn at a temperature of  $-30^{\circ}\text{C}$  (or  $-20^{\circ}\text{C}$ ). Such disagreement may be attributed to the difficulty in measuring the amount of ice at very low temperatures.

The heat liberation can be determined with a Calvet calorimeter in small temperature intervals (for example, at intervals of  $10^{\circ}\text{C}$ : from  $-20$  to  $-30^{\circ}\text{C}$ , from  $-30$  to  $-40^{\circ}\text{C}$ , etc.). The formation of small amounts of ice can be measured precisely. For example, about 15 cal are liberated if 10 g of birch twigs are cooled in the Calvet calorimeter from  $-40$  to  $-50^{\circ}\text{C}$ . One per cent of this heat conforms to ice formation less than 2 mg. Ice formation of 10 mg in amount can be determined if the measurement accuracy amounts to 5 per cent of the total heat that is produced at temperatures from  $-40$  to  $-50^{\circ}\text{C}$ .

I carried out many experiments at intervals of  $10^{\circ}\text{C}$ . Invariably the amount of heat that was produced for the interval of temperature from  $-20$  to  $-30^{\circ}\text{C}$  was less than that for the interval from  $-10$  to  $-20^{\circ}\text{C}$ , also for the interval from  $-30$  to  $-40^{\circ}\text{C}$  the amount of heat produced was less than from  $-20$  to  $-30^{\circ}\text{C}$ , etc. The differences were more than 20 per cent. Such great differences can be explained only when new portions of ice are formed for each interval of decreasing temperature, but these portions decreased with the decreasing temperature. I think that it is quite true that amount of unfrozen water decreases with the decreasing temperature down to  $-60^{\circ}\text{C}$ .

2. My point of view concerning negative temperature in hardening is as follows.

Firstly, it should be noted that the capacity for surviving immersion in liquid nitrogen differed from the degree of frost hardiness of plants. Some plants (winter wheat, cherry trees) can survive immersion in liquid nitrogen but perish at frost below  $-40^{\circ}\text{C}$ . To develop high frost hardiness in woody plants in autumn the temperatures of  $-5$  and  $-10^{\circ}\text{C}$  are the most effective. At temperatures below  $-20^{\circ}\text{C}$  the hardening effect is negligible if the fruit trees have not been subjected to higher subzero temperatures.

After the action of the temperatures of  $-5$  and  $-10^{\circ}\text{C}$  for 20 days (Table 1. in Krasavtsev, 1967), Antonovka apple trees could withstand only  $-30^{\circ}\text{C}$  if the cooling was carried out at speed  $5^{\circ}\text{C}$  per hour. When the twigs were subjected to temperatures ranging from  $-15$  to  $-55^{\circ}\text{C}$  for 8 days after the action of temperatures of  $-5$  and  $-10^{\circ}\text{C}$ , only the xylem was damaged (Krasavtsev, 1960). The present fact shows that high frost hardiness is ensured under slow cooling at  $-20^{\circ}\text{C}$  and below.

The birch twigs can withstand to frost to  $-70^{\circ}\text{C}$  immediately after long subjecting to a temperature of  $-10^{\circ}\text{C}$  (Krasavtsev, 1960). In this case the temperature of  $-20^{\circ}\text{C}$  is not necessary. But autumn birch twigs can be hardened immediately at  $-20^{\circ}\text{C}$ . I have not done any experiments with willows.

It is a pity that we know little concerning the processes occurring at negative temperatures. Starch to sugar conversion and ice formation do not embrace all changes occurring at negative temperature.

3. As we described, the twigs of birch prefrozen at  $-10^{\circ}\text{C}$  were immersed in liquid nitrogen and then rewarmed in various ways: in air, in cool water, and in warm water. After slow thawing the twigs perished. After rapid thawing in warm water the twigs budded normally. This suggests that the twigs contained unfrozen water (but this water is freezable at temperatures below  $-10^{\circ}\text{C}$ ) and that they can withstand super-low tem-

peratures if cooling and rewarming are rapid. This result is in accordance with your data (Sakai, 1967).

I did not observe any damage of the xylem when the birch twigs frozen at  $-10^{\circ}\text{C}$  were immersed in liquid nitrogen and then rewarmed rapidly. The twigs grew for three weeks, later they perished. The untreated control twigs also perished in three weeks because they too did not take roots.

Generally, the xylem is more sensitive to frost than other tissues. Probably, as you said, the xylem is cooled and warmed more slowly than the cortex, but it is not likely that this is the cause for its sensitivity to immersion in liquid nitrogen. I observed that the xylem of apple trees was damaged at temperatures below  $-45^{\circ}\text{C}$  always in the course of slow stepwise freezing. However, in this case slow cooling is favourable. Damages of the xylem can not always be fatal for the whole plant.

O. A. KRASAVTSEV

### References

- GREATHOUSE, G. A. 1935 Unfreezable water and freezable water equilibrium in plant tissues as influenced by sub-zero temperatures. *Plant Physiol.*, **10**, 781-788.
- KRASAVTSEV, O. A. 1960 Frost hardening of woody plants. In *Physiology of Hardiness of Plants*, Acad. Sci. Press, Moscow, 229-234.
- SAKAI, A. 1967 Survival of plant tissue at super-low temperatures by rapid cooling and rewarming. In *Cellular Injury and Resistance in Freezing Organisms* (E. ASAHINA, ed.), Inst. Low Temp. Sci., Sapporo, 119-130.
- SCHOLANDER, P. F., FLAGG, W., HOCK, R. J. and IRVING, L. 1953 Studies on the physiology of frozen plants and animals in arctic. *J. Cell. Comp. Physiol.*, **42**, Suppl. 1. 1-56.
- STARK, A. L. 1936 Unfrozen water in apple shoots as related to their winter hardiness. *Plant Physiol.*, **11**, 689-711.
- TRANQUILLINI, W. and HOLZER, K. 1958 Über das Gefrieren und Auftauen von Coniferennadeln. *Ber. Deut. Bot. Ges.*, **71**, 143-156.
- WOOD, T. H. and ROSENBERG, A. M. 1957 Freezing in yeast cells. *Biochim. Biophys. Acta*, **25**, 78-87.