



HOKKAIDO UNIVERSITY

Title	Resin Canals in the Wood of <i>Larix leptolepis</i> GORD. (II) : Morphology of Vertical Resin Canals
Author(s)	SATO, Kazuto; 佐藤, 一登; ISHIDA, Shigeo et al.
Citation	北海道大學農學部 演習林研究報告, 39(2), 297-316
Issue Date	1982-09
Doc URL	https://hdl.handle.net/2115/21076
Type	departmental bulletin paper
File Information	39(2)_P297-316.pdf



Resin Canals in the Wood of *Larix leptolepis* GORD. (II)

Morphology of Vertical Resin Canals*

By

Kazuto SATO** and Shigeo ISHIDA**

カラマツ材 (*Larix leptolepis*) の樹脂道 (第2報)

垂直樹脂道の形態

佐藤一登** 石田茂雄**

Contents

Introduction	297
Materials and Methods	299
Results	299
1. Normal vertical resin canals	299
1) Longitudinal cells in a vertical resin canal complex	299
2) Spatial relationship between vertical resin canals and rays	300
3) Irregular-shaped epithelial cells	301
4) Pittings between thin-walled and thick-walled epithelial cells	302
5) Tylosoids	302
2. Traumatic vertical resin canals	303
1) Arrangement of vertical resin canals	303
2) Longitudinal cells in a vertical resin canal complex	303
3) Two-dimensional network of vertical resin canals	304
Discussion	304
Conclusions	310
References	311
要 約	312
Explanation of photographs	314
Photographs (1-41)	

Introduction

Because of the quick growth in early life and the high resistance to a cold climate, Japanese larch (*Larix leptolepis* GORD.) has been widely planted in Hokkaido, especially after World War II. A large amount of larch wood is expected to come

Received February 27, 1982.

* A part of this paper was presented at the 29th Annual Meeting of the Japan Wood Research Society at Sapporo, July 1979.

** Laboratory of Wood Physics, Faculty of Agriculture, Hokkaido University.

** 北海道大学農学部林産学科 木材理学教室

into the market in the future. Not only the larch wood is used for constructional timbers, but also it may be utilized for decorative wooden sheets because of its characteristic figure. Resin, however, exudes from the surface of them, which leads to a serious problem for the use of the latter purpose. Methods to prevent the resin exuding from the surface have been studied and devised. Adequate methods to volatilize the resin have been found now.^{16,17,21)}

Tracheids constitute over 90 percent of the volume of larch wood, and rays constitute about 6 percent of it.¹⁶⁾ Both vertical and horizontal resin canals constitute not more than 0.4 percent of it.^{18,24)} Both of them, however, contain more than 45 percent of the whole of resin in *Picea abies*.⁴⁾ The study on resin canals themselves is required to be made in haste in order to devise the more adequate methods to prevent the exudation of resin.

In such genera as *Larix*, *Picea* and *Pseudotsuga*, cells which constitute a resin canal complex are roughly divided into two layers of cells, i. e., an inner layer and an outer layer. The former consists of epithelial cells, and the latter consists of parenchymatous cells with secondary wall.⁶⁾ In *Pinus* a resin canal complex is divided into three layers of cells,^{1,6,18,25)} i. e., a layer of epithelial cells, that of dead cells the wall of which consists of suberin and that of sheath cells with relatively thick wall.²⁵⁾ Epithelial cells are thin-walled and thick-walled in such genera as *Larix*, *Picea* and *Pseudotsuga*, while all of them are thin-walled in *Pinus*. Only a few thin-walled ones occur in *Larix*.¹⁾

The spatial relationship between vertical resin canals and rays has been investigated in *Larix decidua*,⁹⁾ *Picea abies*²⁵⁾ and *Pinus halepensis*.²⁵⁾ The occurrence of uniseriate rays passing through vertical canals is fairly common in *Picea abies* (about 2-3 per mm of canal length).²⁵⁾

Horizontal resin canals start from vertical ones.^{3,8,22,25)} The connection between vertical and horizontal resin canals is divided into four types of anastomosis with respect to the arrangement of vertical canals and fusiform rays in *Larix decidua*, *Picea abies* and *Pinus sylvestris*.²⁾ The connections between both types of canal do not occur in every case in which they come close together in *Pinus halepensis*.²⁵⁾ The whole system of canals, i. e., vertical and horizontal resin canals are reported not to constitute a three-dimensional anastomosing network in *Pinus halepensis*, because no connections are found between vertical canals situated on different radial planes except for the innermost canals of the first growth ring and the occasional splitting and fusion of the same canal.²⁵⁾

According to I. A. W. A. (1975),¹⁰⁾ a tylosoid is regarded as a proliferation of a thin-walled epithelial cell into an intercellular canal. Tylosoids are observed in *Pinus*¹⁸⁾ and *Picea*,²⁰⁾ while they are not observed in *Larix* and *Pseudotsuga* because of a little occurrence of thin-walled epithelial cells.

Traumatic resin canals are recognized to arise supposedly as a result of injury.^{10,18)} They are abnormally large in diameter sometimes.¹⁰⁾ Longitudinal traumatic resin canals are generally arranged in a tangential row that may extend for an inch or two along a ring.¹⁸⁾ Vertical traumatic resin canals in the present

paper denote the ones that are lined up tangentially along a growth ring over one centimeter. The bifurcation of traumatic vertical resin canals and the fusion between them are observed partially in tangential sections, in *Larix leptolepis*¹⁰⁾ and *Picea canadensis*.²²⁾ The morphology of traumatic vertical canals in *Larix leptolepis* has a strong resemblance to that of resin cysts in *Abies firma* S. et Z.¹⁴⁾

The authors of the present paper have made the study on resin canals for these years, and have already reported the distribution of vertical resin canals in *Larix leptolepis*.¹¹⁾ Afterwards, we have investigated how many types of cells form a vertical resin canal complex, and have observed the bifurcation and fusion of traumatic vertical resin canals. The morphology of epithelial cells and that of tylosoids have also been observed. Principally a scanning electron microscope (SEM) was used for the present observation, because it was a suitable apparatus for the observation of the surface of wood elements.

Materials and Methods

Materials for the present investigation were obtained from a twenty-four-year-old Japanese larch (*Larix leptolepis* GORD.), grown in a plantation in Tomakomai Experiment Forest, Hokkaido University. It was thirteen meters in height and seventeen centimeters in diameter at breast height. Discs were cut from the tree at one-meter intervals. A disc at breast height was made use of principally.

A large number of small specimens (R:1 mm, T:1 mm, L:3 mm) which contained one or more vertical resin canals were obtained from the discs. They were obtained from both heartwood and sapwood, and also from earlywood and latewood. Specimens which contained traumatic vertical canals were obtained from the discs in which they occurred. All the small specimens were dehydrated in a graded series of ethyl alcohol after they were aspirated to avoid air bulbs for two days, and embedded in methacrylate resin (n-butyl methacrylate:methyl methacrylate=6:4). Surfaces of the embedded specimen were planed with glass knives on LKB Ultratome 8800. Both transverse surfaces of it were planed at first, and then a tangential or a radial surface of it was planed to the surface where the vertical canal was apparently observed. Finished specimens were immersed in acetone or xylene alternatively for a week to remove the methacrylate resin from them, and dried in room conditions or by the critical point drying method, subsequently coated with gold using Ion Coater. Principally observations were made with a JSM-2 SEM at 15 kV.

Results

1. Normal vertical resin canals

1) Longitudinal cells in a vertical resin canal complex

All the parenchymatous cells which constituted a vertical resin canal complex were distinguished from tracheids in a transverse section in that they were equipped with simple pits and in that they were more deeply stained than tracheids (Photo

1). They were roughly divided into two types of cell in a transverse surface (i. e., flat cells and square ones with a resemblance to tracheids), though various in size. Longitudinal epithelial cells with thick wall were flat or crescent in a transverse view.

Most of longitudinal epithelial cells were thick-walled. Thin-walled longitudinal ones were only a few and were obviously semicircular (Photo 2). The wall thickness of thin-walled longitudinal ones was about 0.5 microns in both earlywood and latewood. Most of thin-walled longitudinal ones were adjacent to thick-walled longitudinal ones. Thin-walled longitudinal ones adjacent to other elements, e. g., tracheids, were scarcely observed (Photo 3). Thick-walled longitudinal epithelial cells were flat and rectangular in a tangential surface (Photo 4). They were approximately uniform in size. The wall thickness of them was about 3 microns in earlywood and about 5 microns in latewood. The epithelium sometimes consisted of two layers of longitudinal epithelial cells, not only when thin-walled longitudinal ones existed in the epithelium but also when they were absent from it.

Longer parenchymatous cells were sometimes observed in a tangential surface (Photo 4). Their diameter in a tangential direction was approximately equal to that of thick-walled longitudinal epithelial cells, but these parenchymatous cells were longer than them longitudinally. Another type of longer parenchymatous cell was also observed sometimes in a tangential surface (Photo 5). Its tangential diameter was larger than that of thick-walled longitudinal epithelial cells, and was approximately equal to that of strand tracheids. Its longitudinal length appeared to be equal to that of the parenchymatous cells that mentioned first. The first parenchymatous cells were found between longitudinal epithelial cells and strand tracheids (Photo 4) or between these and the second parenchymatous cells. The epithelium of vertical resin canals was in contact with the first parenchymatous cells or the second ones or strand tracheids generally. Sometimes no cells were observed between the epithelium and longitudinal tracheids (Photo 5). Such a trend appeared conspicuous in latewood.

Strand tracheids with spiral thickenings were observed sometimes (Photos 4 and 11). Longitudinal tracheids with them are present at latewood in a juvenile part of wood, in *Larix* and *Picea*.¹⁰ Strand tracheids with spiral thickenings were, however, found at latewood in mature wood, in the present study. Strand tracheids with tangential pittings were observed sometimes even in the region where longitudinal tracheids with such pittings were not found (Photos 4 and 6).

2) Spatial relationship between vertical resin canals and rays

Uniseriate rays came in contact with a normal vertical resin canal frequently (Photos 6 and 7). Generally the uniseriate rays were found between longitudinal epithelial cells and strand tracheids (Photo 6), or between these and the second parenchymatous cells (Photo 7). Sometimes the uniseriate rays pushed out toward a vertical canal (Photo 6). In Photo 7 a uniseriate ray on the right hand of a vertical canal may be in contact with the first parenchymatous cells. The uniseriate ray was separated from the vertical canal by longitudinal epithelial cells.

Uniseriate rays often divided a normal vertical canal into two channels temporarily in the region where they passed through it (Photos 8 and 9). The tangential division and fusion of the same vertical canal occurred commonly in Japanese larch (about 2 per 3 mm of vertical canal length). A vertical canal had a large diameter in the case in which two or more rays divided it into two channels in succession (Photo 10). The penetrating uniseriate rays were enclosed with the epithelium which consisted of a layer of longitudinal epithelial cells or partly two layers of them. No cells were found between the uniseriate ray and the longitudinal epithelial cells.

As same as uniseriate rays, fusiform rays came in contact with a normal vertical resin canal (Photo 11) and divided it into two channels temporarily in the region where they passed through it (Photo 12). The contact between a vertical canal and a fusiform ray in the present paper denotes the case in which ray cells are adjacent to longitudinal epithelial cells and in which a horizontal canal is connected to a vertical one. As are seen in Photos 11 and 12, ray cells of the penetrating fusiform rays are separated from vertical and horizontal resin canals by longitudinal and ray epithelial cells (ray epithelial cells: ones lining horizontal resin canals). No cells were found between the fusiform ray and the longitudinal epithelial cells. Thin-walled ray epithelial cells were separated from other elements by thick-walled ray ones, except resin canals (Photo 11). A vertical canal is apparently connected to a horizontal one in the both photos. In Photo 12 a horizontal canal (H) is connected to a temporarily divided vertical canal (V) which is on the left side of thin-walled ray epithelial cells. A horizontal canal in the penetrating fusiform ray was also connected to temporary vertical canals on both sides of it (cf. Photo 36). The relation between a vertical canal and a fusiform ray was not observed sufficiently because of less occurrence of fusiform rays as compared with uniseriate rays (less than one sixtieth).

A small network of normal vertical resin canals was found sometimes (Photo 13). One normal vertical canal was observed on an upper and a lower transverse surface of one specimen. This canal was present alone at latewood in heartwood. Vertical resin canals were found more frequently in heartwood (juvenile wood) than in sapwood, but they did not line up tangentially and did scatter all over the growth ring roughly.

3) Irregular-shaped epithelial cells

Irregular-shaped epithelial cells were observed in the region where rays passed through the middle of vertical resin canals. Slender longitudinal epithelial cells were adjacent to an upper and a lower end of a penetrating ray (Photos 10 and 14). Irregular-shaped longitudinal epithelial cells were sometimes found in the vicinity of an end of the rays (Photo 10). Epithelial cells which looked like bridges were also found beside an end of them (Photo 14). Most of these bridge-like cells were thin-walled in sapwood. It is not evident whether these bridge-like cells occur beside both ends of a penetrating ray.

At the connected part between a vertical and a horizontal resin canal, two

types of epithelial cell were observed: tapering ray epithelial cells (Photos 11 and 12), and longitudinal epithelial cells which appeared to separate a vertical canal from a horizontal one (Photos 11 and 12). The longitudinal epithelial cells ("s" in Figs. 2~4) appeared to also occur on one side of a horizontal resin canal in the case in which a fusiform ray divided a vertical canal into two channels temporarily (Photos 12 and 36). These two types of epithelial cell were thin-walled at latewood in sapwood. In *Larix laricina* a large number of ray epithelial cells with thin wall are found at latewood in sapwood.¹⁹ In Japanese larch many of them would be also present at latewood in sapwood.

Cylindrical epithelial cells were rarely observed in the epithelium of normal vertical resin canals. They were thin-walled in sapwood (Photo 15) and thick-walled in heartwood (Photo 16). It is uncertain whether the cylinder is composed of one or more epithelial cells. A tangentially oblique stretching was sometimes observed in the epithelium of normal vertical resin canals (Photo 17).

4) Pittings between thin-walled and thick-walled epithelial cells

Thick-walled longitudinal epithelial cells were equipped with simple pits. Their simple pits toward thin-walled longitudinal epithelial cells adjacent to them will be described in the next paragraph.

Thick-walled longitudinal epithelial cells adjacent to thin-walled longitudinal ones were always equipped with simple pits toward the thin-walled ones (Photo 18). Bridge-like epithelial cells with thin wall were seen at latewood in sapwood, in the present study. Thick-walled longitudinal epithelial cells adjacent to thin-walled bridge-like cells were also equipped with simple pits toward them (Photo 19). Large longitudinal epithelial cells with thin wall were seen at the connected part between a vertical and a horizontal resin canal. Thick-walled longitudinal epithelial cells adjacent to the large thin-walled cells were also equipped with simple pits toward them (Photo 20). There might be the close relation in the formation of tylosoids between thin-walled and thick-walled epithelial cells through the simple pits.

Simple pits toward vertical resin canals were rarely observed in thick-walled longitudinal epithelial cells (Photos 21 and 22). Thick-walled longitudinal epithelial cells may not be secretory parenchymatous cells.

5) Tylosoids

Tylosoids which originated from thin-walled longitudinal epithelial cells were not observed in vertical resin canals in heartwood. However thin-walled longitudinal epithelial cells which had been crushed were found in vertical canals in heartwood (Photos 23 and 24). Considered from their situation of the formation ("a" in Photo 14, "a" in Photo 24) and from their proportion of the occurrence, thin-walled longitudinal epithelial cells in sapwood might have been crushed during the heartwood formation. Similarly, a thick-walled epithelial cell shown in Photo 25 ("a") might have been thin-walled in sapwood. With the heartwood formation, longitudinal epithelial cells with thin wall would become thick or crushed without expanding toward vertical canals, in Japanese larch.

Tylosoids, which originated presumably from both thin-walled ray and thin-walled longitudinal epithelial cells were observed at the connected part between a vertical and a horizontal resin canal (Photo 26). The wall thickness of the tylosoids was about 1 micron. The tylosoids looked like a plug which occluded a vertical canal. Simple pit pairs were not found between adjacent tylosoids. The tylosoids appeared to be crushed afterwards (Photo 27). Crushed and non-crushed tylosoids were found in the same vertical canal or in different vertical canals in one growth ring. It is not apparent whether the tylosoids originate from ray epithelial cells or both these and longitudinal ones.

2. Traumatic vertical resin canals

1) Arrangement of vertical resin canals

Two types of arrangement of traumatic vertical resin canals were observed in transverse sections, in the present study. One was a loose tangential series (Photo 28). The other was a close tangential series (Photo 29). Traumatic vertical resin canals which form a close tangential series are termed typical ones in the present paper. Traumatic vertical canals in Photo 28 remained a loose tangential series and typical ones in Photo 29 remained a close tangential series in a transverse surface even beside a mass of parenchymatous cells produced as a result of injury. It is not evident whether traumatic vertical resin canals remain a loose or a close tangential series throughout their life.

2) Longitudinal cells in a vertical resin canal complex

Many of vertical resin canal complexes were devoid of the outer layer in the region where traumatic vertical resin canals occurred, especially in the region where typical ones occurred (cf. Photos 39 and 40). The outer layer was found between longitudinal epithelial cells and rays in the case in which it was present in both regions. The first and second parenchymatous cells (cf. p. 300) appeared to be fewer than strand tracheids in both regions.

Abnormal cells were frequently observed in the region where traumatic vertical canals occurred, including epithelial cells. Abnormal tracheids were found beside the region sometimes (Photo 30). An abnormal mass of cells was found rarely. In Photo 31 a ray cell and an abnormal tracheid are shown.

Abnormal epithelial cells with various shapes were frequently observed in the epithelium of traumatic vertical canals. They were thin-walled or thick-walled (Photo 32). Thick-walled abnormal epithelial cells appeared to be fewer than thin-walled ones. The occurrence of cylindrical epithelial cells was most frequent of all the abnormal epithelial cells (Photos 33 and 34). Thick-walled cylindrical cells appeared to be fewer than thin-walled cylindrical cells. All the cylinder traversed vertical resin canals radially. Tangentially oblique stretchings were also found in traumatic vertical canals.

Normal and abnormal longitudinal epithelial cells with thin wall were crushed without expanding toward vertical resin canals during the heartwood formation (Photo 33), as same as thin-walled longitudinal ones in the epithelium of normal

vertical resin canals. Thin-walled longitudinal epithelial cells which were not crushed during the heartwood formation, however, occurred sometimes in the epithelium of traumatic vertical canals (Photo 34). Cylindrical epithelial cells were most of all the non-crushed thin-walled cells (cf. Photo 32).

Thin-walled ray epithelial cells (i. e., ones lining horizontal resin canals) expanded toward vertical resin canals and were transformed into tylosoids during the heartwood formation (Photo 35), as same as thin-walled ray ones in the epithelium of normal horizontal resin canals. Tylosoids which had been crushed were also found (Photo 36), as were seen in normal vertical canals. It is not evident whether the crushed tylosoids occur frequently, because of a little occurrence of fusiform rays.

Traumatic vertical resin canals were sometimes occluded with thick-walled tylosoids (Photos 37 and 38). The tylosoids were found in sapwood in crown-formed wood. Thick-walled tylosoids occurred to a considerable extent longitudinally, and their shapes were various. Simple pit pairs appeared to be present between adjacent thick-walled tylosoids (Photo 38).

3) Two-dimensional network of vertical resin canals

Photo 39 shows a tangential surface of a loose tangential series. A uniseriate ray once divides a traumatic vertical canal into two channels (No. 1 in Photo 39). Each canal which has occurred as a result of a division of an original canal divides into two channels again (Nos. 2 and 3 in Photo 39). Traumatic vertical canals bifurcated tangentially again and again. Photo 40 shows a tangential surface of a close tangential series. The bifurcation of vertical resin canals and the fusion between them occurred frequently in the case of typical traumatic vertical canals. A two-dimensional network of vertical canals was formed in a tangential plane as was the case with a typical traumatic type.

The bifurcation of traumatic vertical canals was caused by the presence of rays in most cases. The other elements, e. g., abnormally short tracheids (cf. Photo 31) or a mass of two or more epithelial cells (Photo 41) seldom caused the bifurcation of them. Rays which consisted of five cells or less appeared to occur frequently in the region where traumatic vertical canals were present, especially in the region where typical ones were present. It is not apparent whether or not a large number of small rays are produced as a result of injury.

As a result of injury, traumatic vertical resin canals were formed in the wood, but on the other hand traumatic horizontal resin canals appeared not to be formed in it in Japanese larch.

Discussion

On the basis of the present observation, the model of vertical resin canal complex was made in Japanese larch (Fig. 1). The vertical canal complex is considered to be composed of five types of longitudinal cells. (1) Thin-walled longitudinal epithelial cells: parenchyma cells which are obviously semicircular and which are much fewer than thick-walled longitudinal epithelial cells (E. 1). (2)

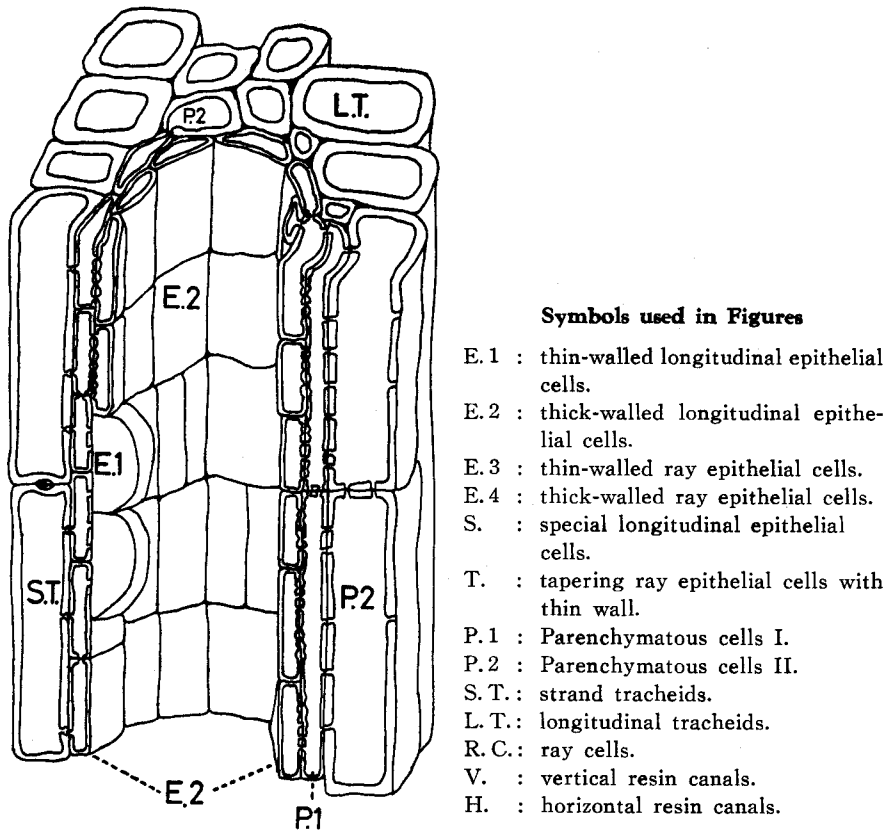

Fig. 1. Diagram of vertical resin canal complex in Japanese larch (*Larix leptolepis* GORD.). The inner layer consists of thin-walled and thick-walled epithelial cells (E. 1 and E. 2). The outer layer consists of Parenchymatous cells I, II and strand tracheids (P. 1, P. 2 and S. T.).

Thick-walled longitudinal epithelial cells : parenchymatous cells with crescent outline in a transverse surface and with depressed outline in a longitudinal surface (E. 2). (3) Parenchymatous cells I: thick-walled longitudinal parenchymatous cells which partly encircle the epithelium (i. e., a layer of epithelial cells). In a transverse surface the outline of them resembles that of thick-walled longitudinal ones longitudinally (P. 1). (4) Parenchymatous cells II: thick-walled longitudinal parenchymatous cells which partly encircle the epithelium. They are as long as Parenchymatous cells I longitudinally, but have a rectangular outline with resemblance to tracheids in a transverse surface (P. 2). (5) Strand tracheids: the epithelium is partly encircled with them. They are as long as Parenchymatous cells II longitudinally (S. T.).

The complex in such genera as *Larix*, *Picea* and *Pseudotsuga* consists of two layers of longitudinal cells, i. e., an inner layer and an outer layer. According to FUJIKAWA,⁹ the inner layer is composed of living and dead longitudinal epithelial cells and the outer layer is composed of longitudinal parenchymatous cells with secondary wall, in outer sapwood.

The vertical resin canal complex in Japanese larch also divides into two layers of longitudinal cells roughly. The inner layer (i. e., the epithelium) consists of thin-walled and thick-walled longitudinal epithelial cells. The outer layer consists of Parenchymatous cells I, II and strand tracheids. Generally the epithelium consists of a layer of longitudinal epithelial cells and partly of two layers of them. Parenchymatous cells I are present between the epithelium and Parenchymatous cells II or it and strand tracheids. The inner layer is cylindrical, while the outer layer is not. The non-cylindrical shape of the vertical canal complex is principally caused by the presence of strand tracheids or by that of Parenchymatous cells II. Considered from this evidence, the outer layer must have strand tracheids. Cells in the outer layer are sometimes absent from the vertical canal complex in latewood. The complex consists, for the most part, of longitudinal epithelial cells only. The vertical canal complex in Japanese larch is not so definit in the arrangement of cells as that in *Pinus*.

Only thin-walled epithelial cells in *Larix* are reported to be true epithelial cells, for thick-walled ones are not equipped with simple pits toward resin canals.⁶⁾ Thick-walled longitudinal epithelial cells are rarely equipped with simple pits toward vertical canals in Japanese larch. They might be, however, secreoty parenchymatous cells. At all events, few thin-walled longitudinal epithelial cells and fewer thick-walled longitudinal ones which had simple pits toward vertical canals were observed in the present study. All the epithelial cells are thought to be thin-walled and to excrete the resin to vertical canals in the vicinity of the cambium. Most of the resin might be produced in epithelial cells in the vicinity of the cambium.

In *Larix laricina* a large number of thin-walled ray epithelial cells are present at latewood in sapwood.¹⁾ In Japanese larch many of them are also found at the connected part between a vertical and a horizontal resin canal, at latewood in sapwood. The resin may be produced mainly in thin-walled ray epithelial cells in sapwood.

In Japanese larch a normal vertical resin canal bifurcates temporarily in the tangential direction when a uniseriate or a fusiform ray passes through it. The occurrence of penetrating uniseriate rays is fairly common in Japanese larch. It is also common in *Picea abies*.²³⁾ It is uncertain whether normal vertical resin canals bifurcate radially or not. They appear not to bifurcate tangentially except for the temporary tangential bifurcation.

A normal vertical resin canal is found to be always connected to a horizontal one, in the cases in which a fusiform ray passes between parenchymatous cells which constitute the vertical canal complex (i. e., a contact between a fusiform ray and a vertical resin canal, Fig. 2) and in which it passes through the middle of vertical resin canals (i. e., a temporary tangential bifurcation of a vertical canal, Figs. 3 and 4). In the case of the latter, a horizontal canal is connected to a temporary vertical canal on one side of the fusiform ray (Fig. 3) or to two ones on both sides of it (Fig. 4). According to H. H. BOSSHARD and U. E. HUG,²⁾

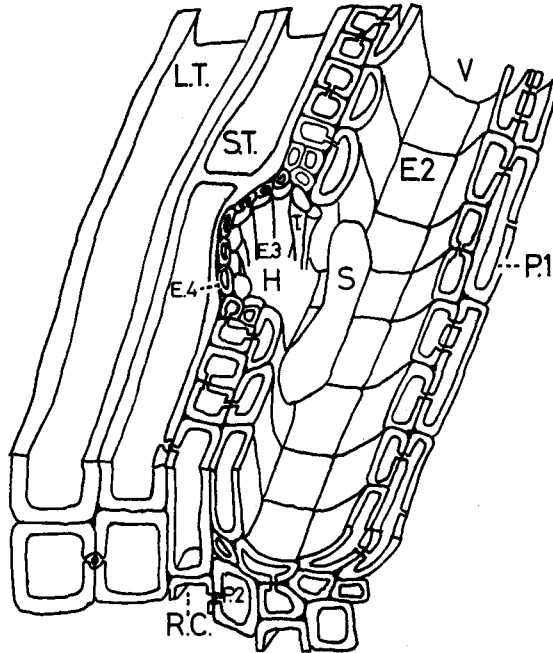

Fig. 2. Diagram of a contact between a fusiform ray and a vertical resin canal and that of a connection between a vertical and a horizontal resin canal. Thick-walled ray epithelial cells are present between thin-walled ray ones and strand tracheids.

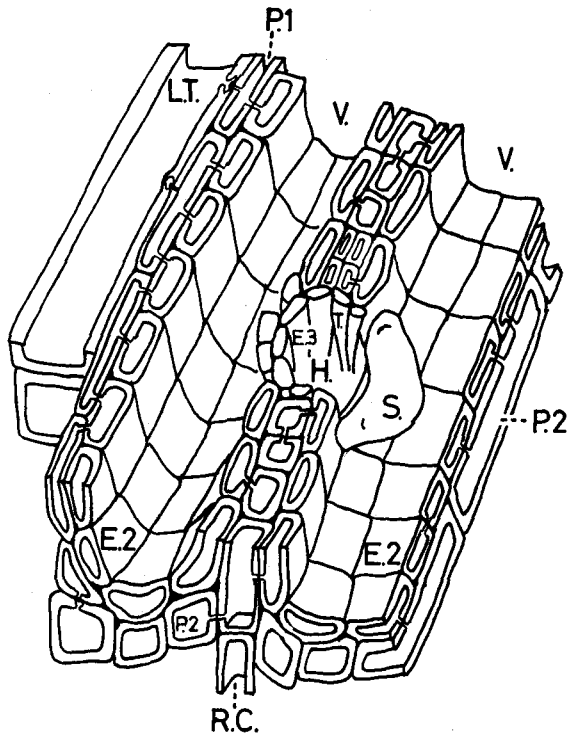

Fig. 3. Diagram of a connection between a vertical and a horizontal resin canal. A horizontal resin canal is connected to a temporary vertical one on the right side of it.

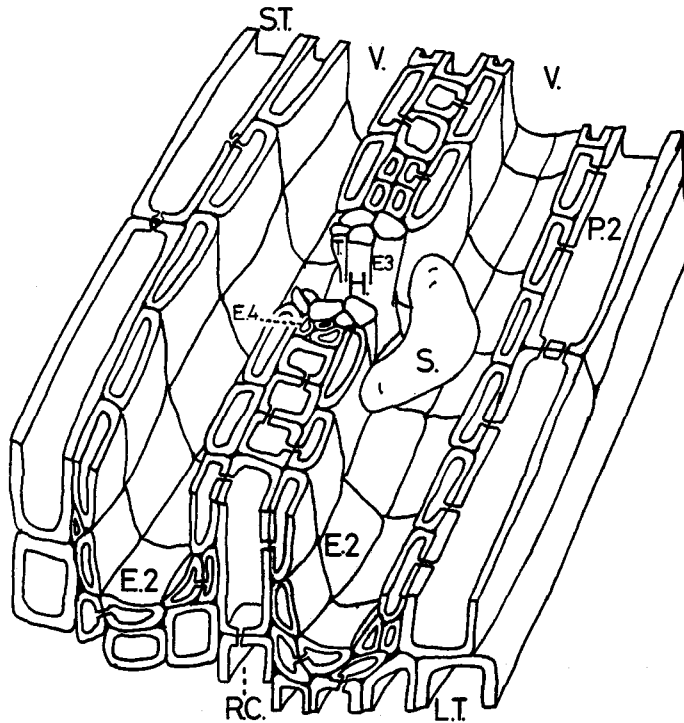

Fig. 4. Diagram of a connection between a vertical and a horizontal resin canal. A horizontal resin canal is connected to temporary vertical ones on both sides of it.

the first (Fig. 3) is regarded as Type 2 A and the second (Fig. 4) is as Type 2 B. The two-dimensional network between different vertical resin canals situated in a radial plane would be formed through a horizontal canal in the secondary xylem. The three-dimensional network might not be formed in the secondary xylem because no connections were found between different vertical canals situated in a tangential plane except for the temporary tangential bifurcation.

Slender epithelial cells are adjacent to an upper and a lower end of a penetrating ray. Irregular-shaped epithelial cells are observed at the connected part between a vertical and a horizontal canal. The schizogenous separation of epithelial cells from one another seems not to occur easily in the case in which a ray divides a vertical canal into two channels temporarily. To study the formation of irregular-shaped epithelial cells, the process of schizogenous separation is required to be observed.

Thick-walled longitudinal epithelial cells adjacent to thin-walled longitudinal ones are always equipped with simple pits toward the thin-walled longitudinal ones. The thick-walled longitudinal epithelial cells might be closely concerned with the thin-walled ones. The alive of parenchymatous cells adjacent to thin-walled epithelial cells might be concerned with the formation of tylosoids, for the content of them might be pushed into the thin-walled ones through simple pits.

Longitudinal epithelial cells with thin wall would be crushed or become thick during the heartwood formation. In the former case they would die before the heartwood formation begins. Thick-walled ones adjacent to the thin-walled ones might also die before the heartwood formation begins. Accordingly, no thin-walled ones can not expand toward vertical resin canals. Thin-walled ray epithelial cells (i. e., epithelial cells lining horizontal resin canals) would expand toward resin canals during the heartwood formation. They would be alive till the heartwood formation ends. Thick-walled ray epithelial cells adjacent radially to the thin-walled ray ones and ray parenchymatous cells adjacent longitudinally to these might be also alive till the heartwood formation ends. Therefore thin-walled ray epithelial cells might be transformed into tylosoids during the heartwood formation. The transformation of thin-walled ray epithelial cells would be different from that of thin-walled longitudinal ones during the heartwood formation.

It is not apparent whether tylosoids situated at the connected part between a vertical and a horizontal resin canal originate from only thin-walled ray epithelial cells or both these and thin-walled longitudinal ones. Few thin-walled epithelial cells in sapwood and few tylosoids in heartwood have been observed in the present study. They are required to be observed hereafter.

Two types of arrangements of traumatic vertical resin canals are observed in the present study. In the genus *Pinus* vertical resin canals which develop as a result of injury are loosely lined up tangentially,¹³ while in such genera as *Abies* and *Tsuga* they are closely lined up tangentially.^{1,14} Both the former and the latter seem to occur in Japanese larch. The fossil data indicate that the localized and restricted distribution of vertical resin canals (*Abies*, *Tsuga*) precedes the scattered and widely dispersed type (*Pinus*).¹² The genus *Larix* might be a middle type between the genus *Abies* and the genus *Pinus*. As mentioned above, traumatic vertical resin canals would have the phylogenetic significance.

Longitudinal cells of which a vertical canal complex is composed are derived from fusiform cambial initials. The first change into such cells is a transverse division of the xylem mother cell. Every parenchyma cell formed by the transverse division undergoes further divisions periclinally and anticlinally to the future canal. Thus epithelial cells occur.²⁵ Longitudinal cells of the outer layer are thought to be formed in the first stage of such a sequence of cell divisions. Because vertical canal complexes of typical traumatic canals are mostly devoid of the outer layer, the xylem mother cells might change into only longitudinal epithelial cells as a result of injury.

Various kinds of abnormal cells are frequently observed in the region where traumatic vertical resin canals are present, especially in the region where typical ones are present. Abnormal epithelial cells are most observed in all the abnormal cells. They are roughly divided into two types of cell, i. e., a cylindrical cell and another one with irregular shape. Irregular-shaped epithelial cells are also found sometimes in the epithelium of normal vertical canals. However cylindrical ones are seldom found in it. The stretching of epithelial cells across a vertical canal

is reported to be formed in *Picea canadensis*¹⁰ and in *Pinus elliottii*¹³ when they have not entirely separated from one another but have maintained contact at one or more points. Many of longitudinal epithelial cells arising as a result of injury would not entirely separate from one another but remain having contact at one or more points. The schizogenous separation of the longitudinal epithelial cells might not occur normally. A large number of abnormal longitudinal epithelial cells are thought to be produced as a result of injury.

Traumatic vertical resin canals in sapwood are sometimes occluded with thick-walled tylosoids. The thickening and lignification of longitudinal epithelial cells might not occur normally as a result of injury.

In Japanese larch vertical resin canals which develop as a result of injury bifurcate tangentially again and again. Typical traumatic canals bifurcate frequently, so that a network of them is formed in a tangential plane. Whether vertical resin canals are normal or traumatic seems to depend on the frequency of bifurcation of them.

The bifurcation of traumatic vertical resin canals is thought to be caused by the presence of rays. Rays which consist of five cells or less appear to occur frequently in the region where traumatic vertical canals are present. After wounding the cambium at first produces a wood layer 10-20 tracheids thick without vertical canals, canals being formed only afterwards.⁶ A time lag is present between the wounding and the formation of vertical canals.⁶ Small rays might be newly produced during the time lag. They might induce the formation of traumatic vertical canals. The distance from pith at which the number of rays per sq. mm becomes constant is about 5~7 cm in radius in *Cryptomeria japonica*.⁷ Traumatic vertical canals are also observed in mature wood where the number of rays is constant, in the present study. It is not yet evident whether or not rays are newly produced as a result of injury.

Conclusions

In such genera as *Larix*, *Picea* and *Pseudotsuga* the epithelium consists of both thin- and thick-walled epithelial cells. The proportion of thin-walled epithelial cells in the epithelium of vertical resin canals is lowest in *Larix* and highest in *Picea* in the three genera.¹⁰ The resin canal complex of *Larix*, *Picea* and *Pseudotsuga* is reported to be divided into two layers of cells by FUJIKAWA.⁶ We consider in Japanese larch that the inner layer of vertical resin canal complex is composed of thin-walled and thick-walled epithelial cells and that the outer layer of it is composed of two types of longitudinal parenchymatous cells and strand tracheids. The former is considered to be the same as that by FUJIKAWA, but the latter is different from that by him. The arrangement and kind of cells which constitute a resin canal complex seem to be different among three genera, i. e., *Larix*, *Picea* and *Pseudotsuga*. The idea of resin canal complex would be a criterion that distinguishes between coniferous woods.

Pittings between thick-walled and thin-walled longitudinal epithelial cells have

been observed in the present study. Simple pits are present in the thick-walled longitudinal ones but complementary pits are absent from the thin-walled longitudinal ones. Complementary concavities are only found in the thin-walled longitudinal ones. Because the simple pits do not occur opposite to an intercellular space, they should not be called blind pits. The definition by I. A. W. A. (1975)¹⁰ does not include that of such a pitting. According to I. A. W. A.,¹⁰ the epithelium is regarded as a layer of secretory parenchymatous cells (epithelial cells) that surrounds an intercellular canal or cavity. Epithelial cells are also recognized to be excreting, thin-walled parenchyma cells which surround longitudinal and transverse resin canals.¹⁰ In the present study most of longitudinal epithelial cells have been found to be thick-walled in xylem and the thick-walled epithelial cells have been found to be rarely equipped with simple pits toward vertical resin canals. Only thin-walled epithelial cells which surround resin canals should be called epithelial cells. The new definition is required for thick-walled parenchymatous cells which surround resin canals. As mentioned above, it is hoped that the definition by I. A. W. A. (1975)¹⁰ is reconsidered.

The formation of tangential series would be a characteristic of traumatic vertical resin canals. The vertical resin canal complex of traumatic ones is often devoid of the outer layer. Abnormal epithelial cells are frequently observed in the epithelium of traumatic vertical resin canals. The bifurcation of traumatic vertical resin canals and the fusion between them occur so often, which is considered to be one of characteristics of them. Evidently traumatic vertical resin canals are considered to be anatomically different from normal ones. The cause of formation of traumatic vertical resin canals might be different from that of normal vertical resin canals.

References

- 1) BANNAN, M. W.: Vertical resin ducts in the secondary wood of the Abietineae. *The New Phytologist*. **35**: 11-47, 1936.
- 2) BOSSHARD, H. H. and U. E. HUG: The anastomoses of the resin canal system in *Picea abies* (L.) KARST., *Larix decidua* MILL. and *Pinus sylvestris* L. *Holz als Roh- und Werkstoff*. **38**: 325-328, 1980.
- 3) CHATTAWAY, M. M.: The development of horizontal canals in rays. *Australian J. Sci. Res.* **B4**: 1-11, 1951.
- 4) ENGSTRÖM, P. and E. BACK: The proportion of canal resin in *Picea abies* KARST. pulpwood. The resin in parenchymatous cells and resin canals of conifers. 8. *Svensk Papperstidning*, årg. 62, Nr. 16. 31 augusti: 545-553, 1959.
- 5) FAHN, A. and E. ZAMSKI: The influence of pressure, wind, wounding and growth substances on the rate of resin duct formation in *Pinus halepensis* wood. *Israel Journal of Botany*. **19**: 429-446, 1970.
- 6) 藤川清三: 針葉樹材構成細胞の膜孔構造の変動, "樹脂道組織の細胞構成, 並びに膜層と膜孔構造", 338-382. Thesis, University of Hokkaido, 1974.
- 7) 藤原新二, 中山義雄: スギ樹幹内の放射組織の分布と放射組織細胞の総数. *J. Jap. Wood. Res. Soc.* **24**(12): 841-845, 1978.
- 8) HALDENBY, C. N.: Horizontal resin canals in the secondary wood of *Larix laricina* KOCH. PH. D. Thesis, University of Toronto, 1940.

- 9) HUG, U. E.: Das Harzkanalsystem im juvenilen Stammholz von *Larix decidua* MILL. Beiheft zu den Zeitschriften des Schweizerischen Forstvereins. No. 61, 73-85, 1979.
- 10) I. A. W. A.: 木材学会誌 21-9: (A1), 1975.
- 11) 今川一志, 佐藤一登, 深沢和三: カラマツ材の樹脂道 (第1報). 垂直樹脂道の樹幹内分布. 木材学会道支部講演集 9: 1-4, 1976.
- 12) JAIN, K. K.: Evolution of wood structure in Pinaceae. Israel Journal of Botany. 25: 28-33, 1976.
- 13) KIBBLEWHITE, R. P. and N. S. THOMPSON: The ultrastructure of the middle lamella region in resin canal tissue isolated from slash pine holocellulose. Wood Sci. Technol. 7: 112-126, 1973.
- 14) 小林弥一: Resin cysts について. 林業試験場研究報告 No. 77: 153-164, 1955.
- 15) 小林弥一, 須川豊伸: 森林火災にかかったカラマツの材質について. 林業試験場研究報告 No. 100: 127-133, 1957.
- 16) 長野県工業試験場: カラマツの工芸的利用. 木材工業 19: 58-62, 1964.
- 17) 大山幸夫, 米田昌世, 千葉宗昭, 奈良直哉: カラマツ材の人工乾燥によるヤニ滲出防止 (第4報). 道立林産試月報 No. 322: 7-12, 1978.
- 18) PANSIN, A. J. and Carl de ZEEUW: Textbook of Wood Technology. —Structure, identification, properties, and uses of the commercial woods of the United States and Canada. fourth edition McGraw-Hill Book Company, 1980.
- 19) 島地 謙, 須藤彰司, 原田 浩: “木材の組織” 森北出版, 114-115, 1976.
- 20) 高原 繁, 野淵 正, 原田 浩, 佐伯 浩: ドイツトウヒにおけるチロソイドの形成. 日本木材学会大会要旨集 30: 57, 1980.
- 21) 種田健造, 川上英夫, 山科 創, 中野隆人: カラマツ材のヤニ滲出防止処理 (第5報) —蒸煮・真空法 (3) —道立林産試月報 No. 322: 13-18, 1978.
- 22) THOMSON, R. B. and H. B. SIFTON: Resin canals in the canadian spruce (*Picea canadensis* MILL. B. S. P.) —An anatomical study, especially in relation to traumatic effects and their bearing on phylogeny. Phil. Trans. Roy. Soc. Lond. B. 214: 63-111, 1925.
- 23) TURNER, S. H., A. P. BUSH and A. J. BOLTON: A note on the spatial relationship between rays and axial resin canals in *Picea abies*. IAWA Bulletin 1979/1: 19-21.
- 24) 渡辺治人: “木材理学総論”, 農林出版 120-121, 1977.
- 25) WERKER, E. and A. FAHN: Resin ducts of *Pinus halepensis* MILL. —Their structure, development and pattern of arrangement. Bot. J. Lin. Soc. 62: 379-411, 1969.

要 約

カラマツ (*Larix leptolepis* GORD.) は、構造用材としてばかりでなく、その特徴的な木理のため化粧用材としても使用される可能性がある。しかし、その材の表面から樹脂が滲出し、後者の目的のためには大きな障害となる。現在までに、数々の樹脂滲出防止方法が開発されてきたが、材中の樹脂総量の半分程が存在する樹脂道自体の研究はあまり進んでいない。より良い防止方法を開発するため、またカラマツ材の特徴をより正しく把握するためにも、樹脂道特にその基本構造が明らかにされねばならない。著者らは先に、垂直樹脂道の樹幹内分布を調査したが、今回、その形態と構造を主として SEM を用いて観察した。

1. 日本カラマツの Vertical Resin Canal Complex を構成する細胞には5種類がある。(1) 薄壁エピセリウム細胞: 垂直樹脂道へ向かって突出した半球形の柔細胞。(2) 厚壁エピセリウム細胞: 木口面では三日月形ないし長方形を呈し、軸方向長さが短い細胞。(3) 柔細胞 I: 木口

面では、形や大きさが厚壁エピセリウム細胞とほぼ同じであるが、それよりも軸方向に長い細胞。(4) 柔細軸 II: 軸方向長さは柔細胞 I とほぼ同じであるが、木口面ではほぼ正方形を呈している細胞。(5) ストラッド仮道管: 外形及びその寸法は柔細胞 II とほぼ同じである。

2 種類のエピセリウム細胞が Complex の内層 (エピセリウム) を構成し、柔細胞 I, II とストラッド仮道管がその外層を構成する。エピセリウムは通常 1 層、部分的に 2 層になっている。晩材では、外層の部分的に欠如した Complex がよく見られる。

2. *Picea abies* と同様、日本カラマツにおいても、1 本の正常垂直樹脂道が単列放射組織 (まれに紡錘形放射組織) を間に挟んで一時的に分岐する現象が頻繁に見られる。

3. 分岐に関与する放射組織の上下の端縁部近辺に、また垂直樹脂道と水平樹脂道の結合部には、特殊な形をしたエピセリウム細胞が見られる。

4. 薄壁な軸方向エピセリウム細胞に隣接する厚壁な軸方向エピセリウム細胞には、薄壁エピセリウム細胞に向けた単壁孔が存在している。厚壁な軸方向エピセリウム細胞には、樹脂道へ向いた単壁孔がほとんど見られない。

5. 薄壁な軸方向エピセリウム細胞は、心材化に伴い厚壁となるかまたは押しつぶされてしまい、チロソイドにはならないと思われる。薄壁な放射方向エピセリウム細胞は、心材化に伴いチロソイドになると考えられる。

6. 典型的な傷害垂直樹脂道の Complex には、外層がほとんど見られない。また、そのエピセリウムには特異な形をしたエピセリウム細胞、特に円筒状の細胞が頻繁に見られる。厚壁のチロソイドでふさがれた傷害垂直樹脂道も時々見られる。

7. 個々の傷害垂直樹脂道の分岐、及びそれらの結合は頻繁に行なわれており、接線面上に垂直樹脂道の network が形成されている。

Explanation of photographs

- Photo 1.** Resin canal complex. All the longitudinal parenchymatous cells that constitute the vertical resin canal complex are more deeply stained than tracheids. A large epithelial cell (e), Parenchymatous cells I (a) and II (b) are shown. Transverse section, at latewood in sapwood.
- Photo 2.** Four longitudinal epithelial cells with thin wall are shown. They are adjacent to longitudinal ones with thick wall. Tangential surface, at latewood in sapwood.
- Photo 3.** It is not apparent whether or not a longitudinal epithelial cell with thin wall is adjacent to tracheids. Tangential pits are observed in a tracheid on the left side of a vertical resin canal.
- Photo 4.** Resin canal complex. The epithelium consists of a layer of longitudinal epithelial cells. Parenchymatous cells I (p) are shown between thick-walled longitudinal epithelial cells and a strand tracheid on the left side of a vertical resin canal. The left strand tracheid has tangential pits. A right strand tracheid has spiral thickenings. Tangential surface, at latewood in sapwood.
- Photo 5.** Resin canal complex. The complex consists of only longitudinal epithelial cells on the right side of a vertical canal. It consists of longitudinal epithelial cells and a mixed strand (a Parenchymatous cell II (p) and a element of strand tracheid (s)) on the left side of a vertical canal. Tangential surface, at latewood in heartwood.
- Photo 6.** Uniseriate rays, which come in contact with a vertical resin canal, push out toward the canal. An upper uniseriate ray (r) is present between a strand tracheid and thick-walled longitudinal epithelial cells. Tangential surface, at latewood in sapwood.
- Photo 7.** A uniseriate ray is present between thick-walled longitudinal epithelial cells and Parenchymatous cells II (p) on the left side of a vertical canal. Tangential surface, at latewood in sapwood.
- Photo 8.** A uniseriate ray divides a vertical canal into two channels temporarily. The uniseriate ray is enclosed with thick-walled longitudinal epithelial cells. Tangential surface, at latewood in sapwood.
- Photo 9.** The same as the state shown in Photo 8. Radial surface, at latewood in sapwood.
- Photo 10.** The temporary bifurcation and fusion of the same vertical resin canal is not apparent because of a large diameter of the canal. Slender epithelial cells (a) and an irregular one (b) are shown. Tangential surface, at latewood in sapwood.
- Photo 11.** A fusiform ray comes in contact with a vertical resin canal. Tapering ray epithelial cells with thin wall (a) and longitudinal epithelial cells with thin wall (b) are shown. Spiral thickenings are seen in a strand tracheid (c). Tangential surface, at latewood in sapwood.

- Photo 12.** A fusiform ray divides a vertical resin canal into two channels temporarily. Tapering ray epithelial cells with thin wall (a) and longitudinal epithelial cells with thin wall (b) are shown. A horizontal resin canal (H) is not connected to a vertical one (V) situated on the right side of the fusiform ray. Tangential surface, at latewood in sapwood.
- Photo 13.** A small network of normal vertical resin canals. Irregular epithelial cells are shown (arrows). Tangential surface, at latewood in heartwood.
- Photo 14.** The temporary bifurcation and fusion of the same vertical resin canal. Bridge-like epithelial cells with thin wall (a) and a slender one (b) are shown. Tangential surface, at latewood in sapwood.
- Photo 15.** Cylindrical epithelial cells with thin wall in the epithelium of a vertical canal. Tangential surface, at latewood in sapwood.
- Photo 16.** Cylindrical epithelial cells with thick wall in the epithelium of a vertical canal. A tangential pit (p) is shown in a strand tracheid on the right side of a vertical canal. Tangential surface, at latewood in heartwood.
- Photo 17.** A tangentially oblique stretching. Tangential surface, at latewood in sapwood.
- Photo 18.** Pittings between thin-walled and thick-walled longitudinal epithelial cells (p).
- Photo 19.** A pitting between a thin-walled bridge-like epithelial cell and a thick-walled longitudinal one (p).
- Photo 20.** Pittings between a large longitudinal epithelial cell with thin wall and a thick-walled longitudinal one (p).
- Photo 21.** Thick-walled longitudinal epithelial cells are equipped with simple pits toward vertical resin canals (arrows).
- Photo 22.** Enlargement of a part of Photo 21. A simple pit toward a vertical resin canal is shown.
- Photo 23.** Crushed cells which originate from thin-walled longitudinal epithelial cells. Tangential surface, at latewood in heartwood.
- Photo 24.** A crushed cell which originates from a thin-walled bridge-like epithelial cell (a). Tangential surface, at latewood in heartwood.
- Photo 25.** Thick-walled bridge-like epithelial cells (a). A crushed thin-walled epithelial cell is also shown (b). Tangential surface, at latewood in heartwood.
- Photo 26.** Tylosoids which originate from thin-walled ray epithelial cells. They appear to expand toward both a vertical and a horizontal resin canal. Tangential surface, at latewood in heartwood.
- Photo 27.** Crushed tylosoids which originate from thin-walled ray (a) and thin-walled longitudinal epithelial cells (b). Tangential surface, at latewood in heartwood.
- Photo 28.** Traumatic vertical resin canals are loosely lined up tangentially. Transverse section, at earlywood in heartwood.
- Photo 29.** Traumatic vertical resin canals are closely lined up tangentially. Transverse section, at earlywood in sapwood.

- Photo 30.** Abnormal tracheids, beside a mass of wound parenchymatous cells. Transverse section, at earlywood in heartwood.
- Photo 31.** A mass of abnormal cells. A ray cell (r), an abnormal tracheid (t) and thick-walled longitudinal epithelial cells are shown. Tangential surface, at earlywood in sapwood.
- Photo 32.** Thick-walled abnormal epithelial cells (e) and cylindrical epithelial cells with thin wall (c) are shown. Tangential surface, at latewood in heartwood.
- Photo 33.** Cylindrical epithelial cells with thick wall (c) and a crushed epithelial cell with thin wall (t) are shown. Tangential surface, at latewood in heartwood.
- Photo 34.** A cylindrical epithelial cell (c), an abnormal one (i. e., a tangential stretching, "s") and a thin-walled intact one are shown. Tangential surface, at latewood in heartwood.
- Photo 35.** Tylosoids at the connecting part between a vertical and a horizontal resin canal. It is not apparent whether crushed tylosoids (t) originate from thin-walled ray or thin-walled longitudinal epithelial cells. Tangential surface, at latewood in sapwood.
- Photo 36.** Crushed tylosoids which originate from thin-walled ray epithelial cells (t). Large longitudinal epithelial cells with thick wall are also shown (s). Tangential surface, at latewood in sapwood.
- Photo 37.** Traumatic vertical resin canals are occluded with thick-walled tylosoids. They are beside a mass of wound parenchymatous cells. Transverse section, at earlywood in sapwood.
- Photo 38.** Thick-walled tylosoids with various shapes occur longitudinally to a considerable extent. Simple pit pairs appear to be present between adjacent tylosoids. Tangential section.
- Photo 39.** A tangential view of a loose tangential series. A vertical resin canal (V) once bifurcates tangentially (No. 1) and each canal which has occurred as a result of a bifurcation of an original canal bifurcates tangentially again (Nos. 2 and 3).
- Photo 40.** A tangential view of a close tangential series. "V" designates a vertical resin canal. A network of vertical resin canals is formed on a tangential surface.
- Photo 41.** An abnormal mass of two or more longitudinal epithelial cells (m). Tangential surface.

