



# HOKKAIDO UNIVERSITY

Title	Marking Method by Electrical Stimulation for Studying Xylem Formation IV : Occurring Area of the Crushed Tracheids
Author(s)	IMAGAWA, Hitoshi; 今川, 一志
Citation	北海道大學農學部 演習林研究報告, 42(3), 585-594
Issue Date	1985-09
Doc URL	<a href="https://hdl.handle.net/2115/21144">https://hdl.handle.net/2115/21144</a>
Type	departmental bulletin paper
File Information	42(3)_P585-594.pdf



**Marking Method by Electrical Stimulation for  
Studying Xylem Formation IV\***  
**Occurring Area of the Crushed Tracheids\*\***

By

**Hitoshi IMAGAWA\*\*\***

木部形成研究のための電氣的刺激による  
マーキング法 (第4報)\*

押しつぶされた仮道管の出現域\*\*

今川一志\*\*\*

**Contents**

Introduction . . . . .	585
Materials and Methods . . . . .	586
Results and Discussion . . . . .	587
1. Influenced cells . . . . .	587
2. Occurring areas of the marking . . . . .	590
Conclusion . . . . .	593
Acknowledgement . . . . .	593
References . . . . .	593
摘 要 . . . . .	594

**Introduction**

The greater part of the so-called radial growth in forest trees is mainly accomplished through a successive accumulation of the xylem cells which are newly produced by the cambium. For this reason, many investigators have expressed a strong interest in the progress of the xylem formation. And furthermore quantitative explanation about xylem formation, i. e. seasonally increasing process of the newly formed cells have been also required from a practical field such as a tree breeding. Therefore, studies to quantitatively examine the process have been numerous undergone and reported. In such cases, it is very important to determine what sorts of experimental methods for pursuing the process are used, because the results obtained were restricted to some extent based on the experimental method

---

\* Report III: This Bulletin, 40 (1983).

\*\* Received February 28, 1985. This report was presented at the 34th Annual Meeting of Japan Wood Research Society, April, 1984, Nagoya.

\*\*\* Laboratory of Wood Physics, Faculty of Agriculture, Hokkaido University, N9, W9, Kitaku, Sapporo, Japan. 北海道大学農学部木材理学講座

employed. However, it is considered that fully satisfactory method for explaining the increasing process was not still introduced.

From such view point, marking method by electrical stimulation was newly introduced to inscribe a given date in the current xylem. This method was already examined in *Abies sachalinensis*,<sup>1)</sup> *Pinus luchuensis*,<sup>2)</sup> *Larix kaempferi*,<sup>3)</sup> *Alnus japonica*,<sup>4)</sup> *Cinnamomum camphora*<sup>5)</sup> and *Avicennia marina*,<sup>6)</sup> and the possibility for a practical employment of this method was recognized. In these species, several sorts of the influenced cells such as radially crushed, immature or abnormally shaped cells occurred in the current xylem resulting from the application of electrical stimulus through the electrodes. Among these cells, radially crushed cells seem to be most suitable for marking xylem because they are tangentially aligned along the annual ring boundary and regarded as a line macroscopically. And also it was clarified that they occurred within 24 hours after the application of the electrical stimulus and the differentiating tracheids immediately after the initiation of the deposition of S 2 layers were radially crushed.<sup>3)</sup> In this study, the occurring areas in which the crushed tracheids were located were pursued and measured in the current growth layers.

### Materials and Method

Two young (about 10 year-old) Todo-matsu, *Abies sachalinensis* grown at the tree nursery in the campus of Hokkaido University were examined. Three sorts of electrical stimuli, i. e. weak (24 volts), medium (70 volts) and strong (215 volts) were applied for 5 seconds to the electrodes (0.5 mm in diameter, 14 mm in length, stainless steel), which were axially spaced 5 cm apart and inserted through the bark into the previous growth rings. On 8th of July in 1983, three sorts of the stimuli were applied respectively to the three positions at the lower parts of the stems, and again on 18th at the upper parts similarly. On 25th of Nov. (dormancy), the trees were fallen and the transverse disks (1 cm in thickness) were successively cut from

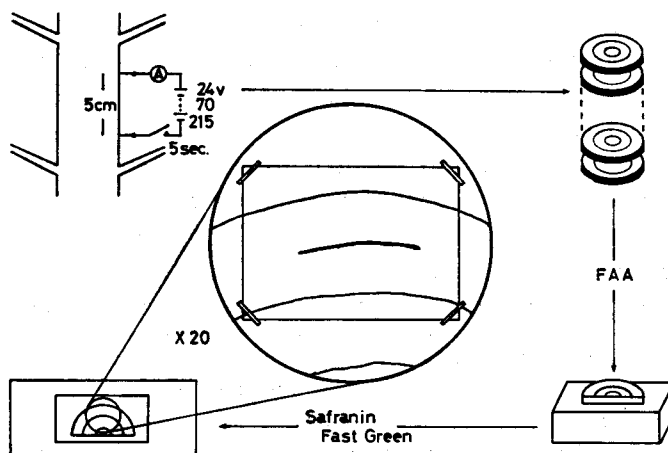

Fig. 1. Experimental method.

the each position to which the electrical stimulus was applied. They were fixed in FAA solution, and then washed in water. The transverse sections were cut from each disk on a sliding microtome, stained with safranin and fast green, mounted usually and observed. In each section, the marking lines, i. e. tangentially aligned crushed tracheids were described on tracing papers at the screen of a profile projector (Nikon), and then the length of them in arc was measured by curvometer (Fig. 1). And also, the other influenced cells such as immature tracheids, abnormally shaped cells and traumatic resin canals observed in each section were simultaneously described on the tracing papers. Based on the each measurement in the successive sections, the occurring areas (longitudinal and tangential direction) of the crushed tracheids in the current growth layers were reconstructed and described schematically. The results obtained will be separately mentioned as follows; the influenced cells and the occurring areas of marking lines.

## Results and Discussion

### 1. Influenced cells

As morphological differences in the influenced cells were not recognized between the upper and the lower parts of each stems, typical examples in each sort of the stimulus are indicated.

Fig. 2 shows the transverse section obtained from the portion very near the weak stimulus electrode. The bark was peeled out. Two cracks are found in the previous growth ring by the insertion of the electrode (wedge). At the center in the current growth ring, small cavity is observed (arrow). It seems to result from the burn of the surrounding tissues which were directly subjected to the heat of the electrode generated by the electric currents.<sup>1)</sup> Two short rows of the crushed tracheids extend toward both sides from the middle part of the cavity. Each is about 1 mm in length. A few of the immature tracheids are located at the pith side of these rows, and furthermore they also follow the crushed tracheids in short distance. Although the immature tracheids are stained green with fast green, they can not be distinguished clearly in this figure.<sup>3)</sup> A small amount of the abnormally shaped cells and the traumatic resin canals are found at the bark side of the cavity. It is presumed that the convex portion of the current growth ring boundary resulted from the increased xylem formation which is frequently observed after the injury, i. e. the insertion of the electrode.

Fig. 3 shows the transverse section from the middle portion between the upper electrode and the lower one, to which the weak stimulus was applied. There is no sign of the influences derived from the application of the weak stimulus. In the weak stimulus, consequently, the crushed tracheids and the other influenced cells occurred only very near the electrodes. The weak stimulus seems to be almost similar to the pinning method which was originated by WOLTER.<sup>6)</sup>

Fig. 4 indicates the transverse section from the portion near the medium stimulus electrode. Radial crack is also found in the current growth ring, which may be derived from the insertion of the electrode (wedge). Short line extends

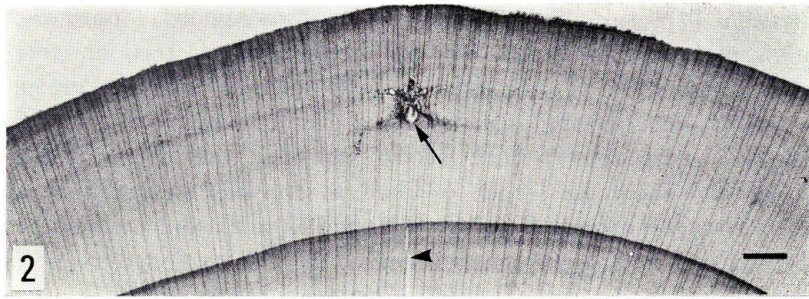

Fig. 2. Transverse section from the portion near the weak stimulus electrode. scale bar: 1 mm.

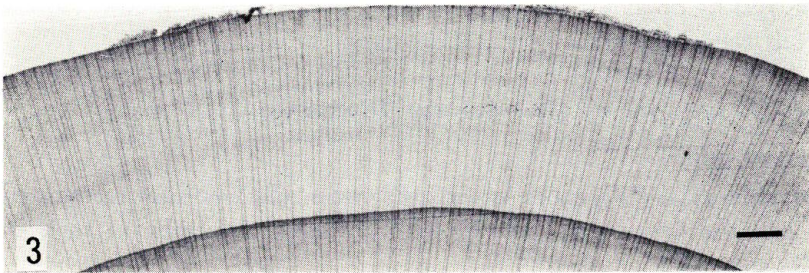

Fig. 3. Transverse section from the middle portion between the weak stimulus electrodes. scale bar: 1 mm

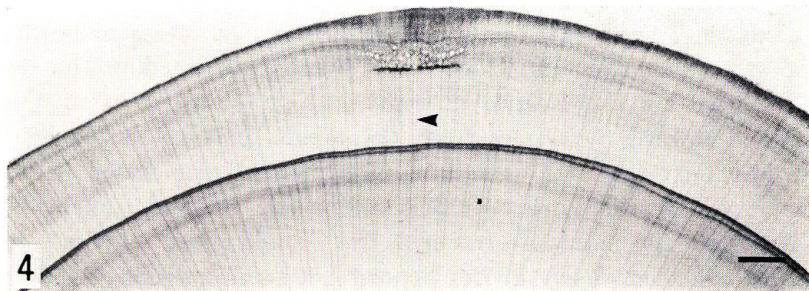

Fig. 4. Transverse section from the portion near the medium stimulus electrode. scale bar: 1 mm.

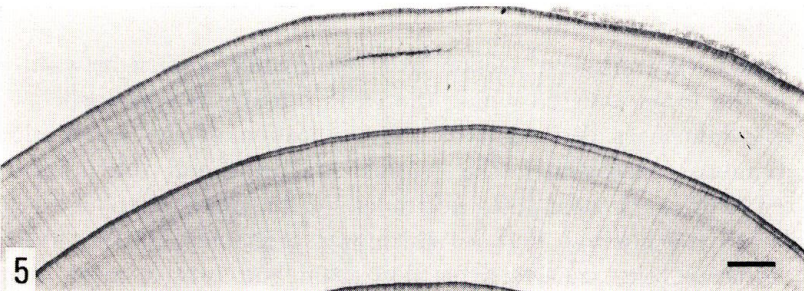

Fig. 5. Transverse section far from the medium stimulus electrode. scale bar: 1 mm

tangentially about 2 mm at the center of the current growth ring. This is composed of several crushed tracheids in each radial file of cells. Abnormally shaped cells are located at the bark side of the crushed tracheids, and the traumatic resin canals extend tangentially following them. As seen in Fig. 2, a few of immature tracheids exist at the pith side of the crushed tracheids, and also follow them in tangential direction. Immature tracheids are also obscure in this figure such as Fig. 2.

Fig. 5 shows the transverse section about 10 mm apart from the medium stimulus electrode. A line composed of the crushed tracheids is found almost similar portion to in Fig. 4. Although the immature tracheids are also located in the same manner as the case near the electrode, abnormally shaped cells and the traumatic resin canals are little observed. It is interesting that any influenced cells other than a few of the immature tracheids were not found at the middle portion between the electrodes.

Fig. 6 is the transverse section from the portion near the strong stimulus electrode. The xylem formation is seriously influenced by the strong stimulus. Large cavity is found, and the tracheids adjacent to it seem to be burned out by the heat generated. There are also immature tracheids at the pith side of the cavity. Crushed tracheids follow the cavity tangentially such as a tail of the cavity and furthermore immature tracheids are successively located for a short distance. Two rows of the traumatic resin canals run parallel to the crushed tracheids. The upper one of the two rows are followed by the band of the thick-walled tracheids, which are observed black tangential band in this figure. Although they seem to be derived from the application of the stimulus, the reasons why such thick-walled tracheids were produced in tangential band are not still clear in this study. At the bark side of the cavity, group of abnormally shaped cells is observed. Because this section is located somewhat far from the electrode, the abnormally shaped cells were abundantly produced so that the cavity was almost completely embedded by them. In the case of the section very near the electrode, the cavity opened throughout the following xylem and the bark.

Fig. 7 shows the transverse section from the middle portion between the strong stimulus electrodes was applied. Crushed tracheids are remarkably aligned tangentially or in an arc along the growth ring boundary. This marking line extends about 14 mm. And also, immature tracheids follow the arc tangentially and occur at the pith side of it. Almost linear and short row of the traumatic resin canals is located at the bark side more or less far from the marking line. However the abnormally shaped cells existed infrequently. Limited to this middle portion, it is considered that such row of the crushed tracheids is most suitable for marking.<sup>9)</sup>

Fig. 8 indicated the transverse section at the about 15 mm upper portion far from the electrode. This marking line is short but distinctive. Traumatic resin canals are observed at the bark side far from the crushed tracheids. However, both rows of the traumatic resin canals at the right and left side did not result from the strong stimulus which produced this marking line. Immature tracheids

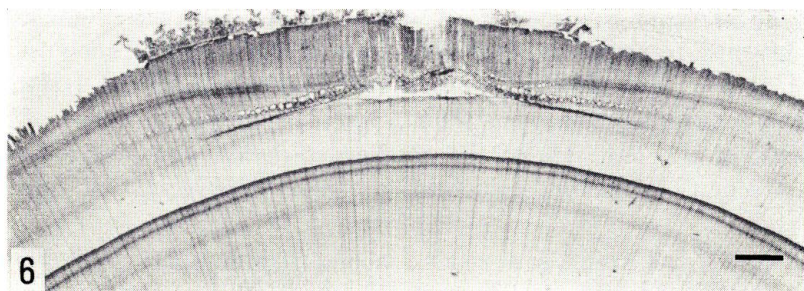

Fig. 6. Transverse section from the portion near the strong stimulus electrode. scale bar : 1 mm.

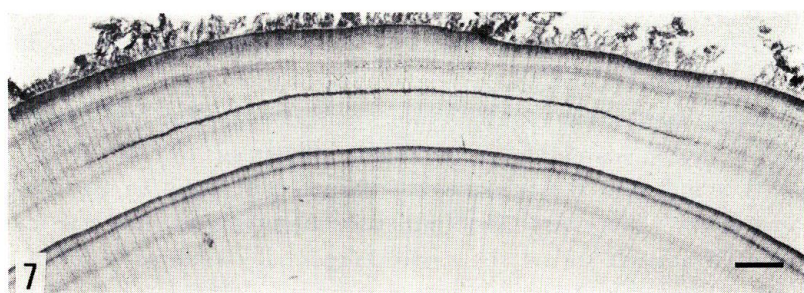

Fig. 7. Transverse section from the middle portion between the strong stimulus electrodes. scale bar : 1 mm.

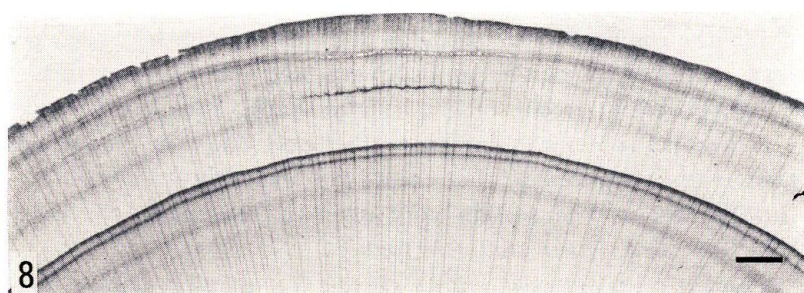

Fig. 8. Transverse section from the upper portion far from the strong stimulus electrode. scale bar : 1 mm.

occur in a similar way to that mentioned above.

Based on these observation, it can be concluded that the length of the marking line varies considerably corresponding to the extent of the stimuli applied and the distance from the electrodes. In all cases, the tissues surrounding the electrodes were seriously influenced, so that it is considered that such portions are unsuitable to be employed for marking.

## 2. Occurring areas of the marking

Based on the measurements in the longitudinally successive disks, the occurring areas of the crushed tracheids in the current growth layers are schematically re-

presented. Since the rows of the crushed tracheids were usually followed by the immature tracheids for a short distance, the occurrence of the immature tracheids is also described to the diagrams. However abnormally shaped cells and traumatic resin canals are not indicated because they are unnecessary for marking.

Fig. 9 exhibits three diagrams of the occurring areas in the current growth layers, where crushed tracheids (solid line) and immature tracheids (oblique line) occurred by the weak stimulus are described. Although the occurring areas of the crushed tracheids are practically measured and exactly represented, immature tracheids are shown only to be located, and the extent of the areas are meaningless. The same stimuli were applied to four positions, but one of them failed to be collected. As shown in Figs. 2 and 3, crushed tracheids occurred only very near the electrodes in every cases. The areas are very small and developed more or less longitudinally.

In Tree 2-2, the area is most elongated (about 10 mm) and widened (about 1.8 mm). However, the close relationships between the maximum electric currents for 5 seconds and the extent of the occurring areas may not be found. Although the reason why such differences occurred in each position is not clear, it may be derived

from the differences in the rate of the xylem formation. While, the each area surrounding the lower electrode (minus) are larger than the upper ones (plus). And also it is obscure what such differences are resulted from. Immature tracheids are found only to surround the areas of the crushed tracheids, and not at the other portions. Judging from the extent of the occurring areas, it is apparent that the weak stimulation is unsatisfactory to mark xylem.

Fig. 10 displays the cases to which the medium stimulation was applied. The occurring areas of the crushed tracheids are apparently larger than that in the weak stimulus (Fig. 9). Especially, the areas are conspicuously enlarged in axial direction. In all cases, they are elongated upward and downward from the electrodes. However, the areas are more remarkably elongated toward the portion between the electrodes than the opposite one. So that, the upper areas from the lower electrodes are nearly axially contact with the

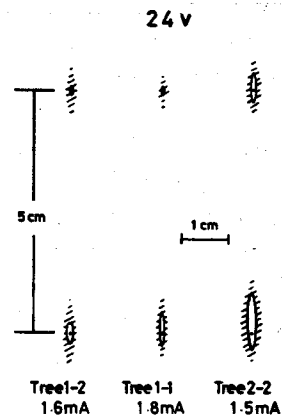

Fig. 9. Occurring areas of the crushed tracheids and immature tracheids in the current growth layer, to which the weak stimulus was applied (24 volts).

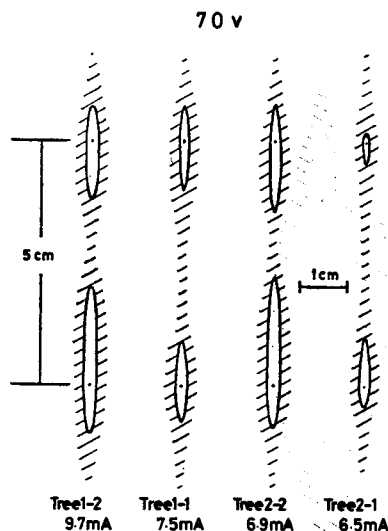

Fig. 10. Occurring areas of the crushed tracheids and the immature tracheids in the current growth layer, to which the medium stimulus was applied (70 volts).

lower ones from the upper ones. As the case of the weak stimulus, the areas derived from the lower electrodes are usually larger than ones from the upper ones. In comparison with the axial extension, the increase of the width is inclined to be less. It is presumed that such difference may be derived from the axial orientation of the tracheids, or the flowing direction of the electric currents which may be depend on such axial orientation. In a similar fashion to the weak stimulus, the extent of the area seems to be irrelative with the maximum electric currents. However the extent of the area in the medium stimulus increases apparently more than that in the weak stimulus. In this sense, the extent of the area may be related with the maximum electric currents.

It is noteworthy that in the medium stimulus only the immature tracheids occurred at the middle portion between the electrodes, where the crushed tracheids were not located. And also the other influenced cells were not found. As the immature tracheids existed at the middle portion, both the immature tracheids from the upper electrode and the lower one were longitudinally continuous. However, there are very fewer of the immature tracheids at the contact portion, so that they are located in a slender gourd-shape (Fig. 10). Both the crushed tracheids and the immature tracheids may be died in the course of their differentiations by the application of the electrical stimulus.<sup>9)</sup> After the death, only some of them were radially crushed, and the others remained almost the same state at that time.

Fig. 11 exhibits the occurring areas produced by the application of the strong stimulus. The areas develop conspicuously in comparison with both the weak and

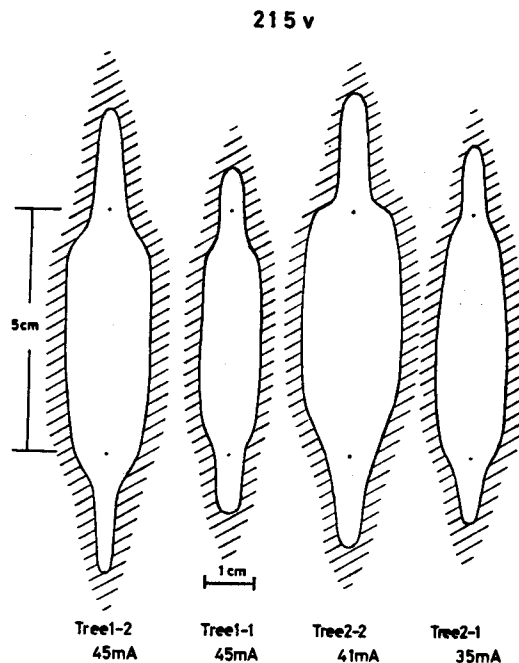

Fig. 11. Occurring areas of the crushed tracheids and the immature tracheids in the current growth layer, to which the strong stimulus was applied (215 volts).

medium stimulus (Figs. 9 and 10). In the strong stimulus both the areas derived from the upper electrode and the lower one are not only completely contact with each other but also extensively widened in a tangential direction at the portion between the electrodes. The tangential width at the middle portion is most large. And the areas at the portions other than the portion sandwiched between the electrodes are also widened and elongated (Fig. 8). The immature tracheids surround the area of the crushed tracheids such as the cases of the weak and the medium stimulus.

Although all the areas are considerably enlarged, they are not same but vary distinctively in size. In Tree 2-1 and Tree 2-2, the extent of the areas and the maximum electric currents are positively related. On the other hand, in Tree 1-1 and Tree 1-2 the extent of the areas are apparently different in spite of the same maximum readings. Therefore, the common relationship throughout both the trees examined is not confirmed. While, Tree 1-1 and Tree 2-1 were stimulated on July 8th, and then Tree 1-2 and Tree 2-2 10 days after. In regard to this point, so-called seasonal factors may be significant to explain these results. And furthermore, the former was located at the lower parts of each stem, and the latter at the upper parts. The age of the cambium at the upper part is apparently younger than one at the lower, and the differentiating tracheids produced by the younger cambium may be more active and sensitive against the same stimuli. For the sake of the more distinctive explanations for such phenomena, furthermore studies are necessary hitherto.

### Conclusion

The occurring areas of the crushed tracheids were enlarged with the increased stimuli from the weak to the strong. In the strong stimulus, the areas were not only continuous axially but also expanded tangentially. Judging from such results obtained, it is presumed that the upper area and the lower one extend axially to be contact with each other at the certain level between the medium and the strong stimulus. It is assumed that the areas are probably continuous at about 150 volts. In regard to most effective marking, least continuity at the middle portion between the two electrodes is most suitable, because the influences from the electrodes are less produced at the portion. Consequently it is necessary to confirm experimentally the most effective level of the stimulus.

### Acknowledgement

The author is grateful to professor K. FUKAZAWA for his kindful encouragement during the course of this study and his critical reading of this manuscript.

### References

- 1) IMAGAWA, H. and ISHIDA, S. (1981): New marking method by electrical stimulation for studying xylem formation, (I), Res. Bull. Coll. Exp. For. Hokkaido Univ., 38: 241-248.
- 2) IMAGAWA, H. and ISHIDA, S. (1982): Preliminary experiment of relationship between elec-

- trical resinace and state of cells in *Pinus luchuensis*, *ibid.*, 39: 127-136.
- 3) IMAGAWA, H. and ISHIDA, S. (1983): New marking method by electrical stimulation for studying xylem formation., (III), *ibid.*, 40: 397-408.
  - 4) IMAGAWA, H. and ISHIDA, S. (1983): ditto, (II), *ibid.*, 40: 387-395.
  - 5) IMAGAWA, H. (1981): Possibility of marking method by electrical stimulation in *Avicennia marina* VIERH., *The Sub-Tropical Forest (Univ. Ryukus)*, No. 3: 19-24.
  - 6) WOLTER, K. E. (1968): A new method for marking xylem growth., *For. Sci.*, 14: 102-104.

## 要 約

樹木の木部形成の季節的経過を、増加して行く細胞数やその幅などで定量的に追求するための一つの実験手法として、電気的刺激による印づけ法（マーキング法）を開発し、これまでの研究で、その手法の有効性を示して来た。本研究では、材中の印づけとしては最適である半径方向に押しつぶされた細胞の接線方向列が、材中において、立体的にどのような範囲にわたって出現するのかを明らかにしようとして進められた。

生長期のトドマツ若齢木の樹幹の3部位に、それぞれ異なる強さの刺激（24, 70, 215 ボルト）を与え、休止期に伐採し、材中でのマーキングの出現域を調査した。また、それと同時に、刺激に影響された細胞についても顕微鏡観察を行なった（Fig. 1）。

24 ボルトで刺激した場合、電極針を挿入した部位の近くでのみ、刺激の影響が見られたが2つの電極の中間部では影響はまったく見出されなかった（Fig. 2, 3, 9）。

70 ボルトで刺激した場合、マーキング域は電極から樹軸方向に幾分拡大し、マーキングの目的はわずかではあるが達成された。しかし、2つの電極の中間部にはマーキングされず、十分なマーキングとは言えないように思われる（Fig. 4, 5, 10）。

215 ボルトで刺激した場合、マーキング域は非常に拡大した。上下2つの電極部から拡大して来たマーキング域は、その中間部で完全に連合し、一つのマーキング域を形作った。軸方向に連合したばかりでなく、接線方向へも拡大し、全体としては2つの電極の中央部で接線方向へふくらんだ形を示した。しかしながら、刺激が強過ぎたせいで、異常な形状の細胞や傷害樹脂道も数多く出現し、マーキング後の生常な木部形成を期待するには刺激が強過ぎると考えられる（Fig. 6, 7, 8, 11）。

以上の結果から考えて、24 ボルトでは弱過ぎ、215 ボルトでは過剰のマーキングがなされると言える。また、電極針の挿入による影響を避けるためには、2つの電極針の中間部を用いる必要があり、そのためには中間部で明確なマーキングが得られることが望ましい。したがって、70 ボルトより幾分強い刺激条件が最良と思われ、それには150 ボルト位の強さが適当であると考えられる。