



HOKKAIDO UNIVERSITY

Title	STUDIES ON BOUND WATER IN FISH MUSCLE
Author(s)	Akiba, Minoru
Citation	MEMOIRS OF THE FACULTY OF FISHERIES HOKKAIDO UNIVERSITY, 9(2), 85-179
Issue Date	1961-11
Doc URL	https://hdl.handle.net/2115/21835
Type	departmental bulletin paper
File Information	9(2)_P85-179.pdf



STUDIES ON BOUND WATER IN FISH MUSCLE

By

MINORU AKIBA

Faculty of Fisheries, Hokkaido University, Hakodate, Japan

CONTENTS

	Page
I. Introduction	86
II. Estimation of the amount of Bound Water in fish meat in various conditions by the cobaltous chloride and by the electrical resistance methods.....	89
1. Experimental methods.....	89
2. Results and consideration	90
(1) Determination of the amount of Bound Water by Oyagi's method	90
(i) Determination of the amount of Bound Water by the cobaltous chloride method on the raw fresh meat of various kinds of fish.....	90
(ii) The amount of Bound Water estimated in the dried meat of several kinds of fish by the cobaltous chloride method	96
(iii) Results obtained by the cobaltous chloride method on the salted fish meat	99
(iv) Results of estimations of the amount of Bound Water in fermented fish meat and decomposed fish meat by the cobaltous chloride method	102
(A) Variation of the amount of Bound Water in soused squid meat ("Shiokara" in Japanese) during its ripening	102
(B) Variation of the amount of Bound Water in the decomposed Atka mackerel meat during the putrefaction	103
(2) Results of estimations by the electrical resistance method on some fish meat	103
(i) Preliminary experiment	104
(A) Relation between the electrical resistance (50 cycles) and the distance of electrodes for various kinds of fish meat.....	104
(B) The electrical resistance of fish meat gruel.....	106
(C) The relation among the water-content in the putrefied fish meat, the electrical resistance and the distance of the electrodes	106
(ii) Results of observations of the electrical resistance at 50 cycles in fresh meat, salted meat and putrefied meat of Atka mackerel at various water-contents.....	109
(3) Conclusions as to the results of estimations of the amounts of Bound Water in the various states of meat of various kinds of fish by the cobaltous chloride method and by the measurement of the electrical resistance	112
III. The influence of Bound Water upon the velocity of drying of fish meat	113
1. Experimental part	114
2. Experimental results and discussion	115
3. Conclusion	131
IV. On the relation between the "Drip" formation and the amount of Bound Water during the refrigeration of fish meat	133
1. Experimental part	134

(1) On the relation between the freshness of the fish meat and the amount of "Drip" formed	134
(2) The relation between the amount of "Drip" formed and the storage period of frozen fish meat	137
(3) The comparison of the curve of the water-content and the water-activity of sample, " <i>g-a</i> " in the fresh raw meat and frozen meat	139
(4) The comparison of curves " <i>g-a</i> " of the fish meat, fish meat dripped out and "Drip" liquid respectively	141
(5) Examination of soaking of fish meat in various kinds of salt solution as a method for preventing the formation of "Drip"	143
2. Conclusion	150
V. Variation of the amount of Bound Water during salting of fish meat	151
1. Experimental part	152
(1) Experiment I (Preliminary experiment)	152
(2) Experiment II	157
2. Conclusion	164
VI. Relation between the decomposition of fish meat protein and the amount of Bound Water during the autolysis of fish meat	165
1. Experiment part	165
2. Conclusion	170
VII. General discussion	171
VIII. Summary	175
Literature cited	177

I. INTRODUCTION

There are three definitions of Bound Water, as stated in the earlier Paper^{1a)}, such as biological, colloidal and molecular theoretical Bound Water, which have been studied from the standpoints of biology, colloidal chemistry and molecular theory respectively. There are many methods for estimating the amount of Bound Water, *e.g.*, chemical, thermodynamic, electro-chemical *etc.*, but some of them adopt different ideas as to the principle of the estimating method^{2c)}.

Studies on Bound Water were first made about the state of water frozen in various substances. For example, Thoenes³⁾, Hardy⁴⁾, Moran⁵⁾, Kinoshita⁶⁾ and Kistler⁷⁾ have observed the amount of unfrozen water in the meat of dogs and other animals, gelatine, myogen, egg-albumin, *etc.* From the physiological and biological standpoint, Plank⁸⁾ has advocated his so-called freezing phase; he has divided into four phases the freezing process of living things within the temperature range from -1°C to -60°C , and has pointed out the existence of biological Bound Water and colloidal Bound Water. Beside the above described studies, Heiss⁹⁾ and Joslyn¹⁰⁾ have discussed the relation between the amount of Bound Water and the change of colloidal properties during the refrigeration of animal kingdom foods.

Furthermore, there have been many studies on the hydrophilic colloid of vegetable juice from many years ago¹¹⁾.

On the contrary, there have been published only a few studies on Bound Water in muscle of marine animals. Higuchi¹²⁾ has studied on the variation of

the amount of Bound Water of squid and flat fish meat in the course of drying. Kawakami¹³⁾, using carp muscle, has assumed the existence of Bound Water in fish muscle from his study on the relation between the depression of freezing point and the variation of water-content in the course of drying.

In the earlier Paper I^{1a)}, the present author has studied on the amount of Bound Water in fish muscle and gelatine by the cobaltous chloride method¹⁴⁾, the vapour tension method and the method by electrical resistance at 50 cycles. The results obtained were compared with each other and the following conclusions were reached.

(1) In the case of estimation by the cobaltous chloride methods (Hatschek's^{14a)} and Oyagi's^{14b)}), the author was able to estimate both the amount of Bound Water at the point of B.P. (the blue turning point of dyed sample) and C.P. (the point of apparent constant weight in the drying at 30°C) on the basis of ideas as to the nature of Bound Water. The author has called the water-content at B.P. the maximum amount of Bound Water and that at C.P. the minimum amount of Bound Water.

(2) When the amount of Bound Water in fish meat and gelatine was estimated by the cobaltous chloride methods, and these results were compared with the values on the curve of water-content—water-activity (or relative vapour pressure) obtained by the vapour tension method, the amounts of Bound Water (gm) per gm of the dried matter (free from cobaltous chloride) of the samples at the points of H.B.P. and H.C.P. by Hatschek's and O.C.P. by Oyagi's method were ascertained to be the water-content corresponding to above 0.8~0.7 of the water-activity, "a". These values will give the probable value which has been considered before as the amount of colloidal Bound Water. The amounts of Bound Water (gm) per gm of the dried matter (containing cobaltous chloride) at the points of O.B.P' and O.C.P' will give also the value of the amount of colloidal Bound Water.

(3) In this cobaltous chloride method, cobaltous chloride which was added to the sample in Hatschek's or which penetrated into the sample in Oyagi's method decreases the activity of water in the sample. The degree of decreasing of the water-activity is different from the activity of water in the original sample. That is to say, it is different from the binding strength of water in the sample. In this case, the hydration of cobaltous chloride with water in the sample is restricted in accordance with the increasing of binding strength of water in the original sample.

(4) In the results of the estimation of the amount of Bound Water, the electrical resistance decreases in accordance with the decreasing of water-content, but it begins increase at about 50% of total water-content. The electrical resistance gradually increases at the point of B.P. which was considered to be shown as the maximum amount of Bound Water (the total water-content, 50~30%) by the cobaltous chloride method, and it increases rapidly at the point of C.P. which was considered to be the minimum amount of Bound Water (about 30~20% of total water-content) by the same method. At below 20% of the water-content, the relation between the increasing of electrical resistance and the water-content showed a logarithmic straight line.

(5) Oyagi's method gives a greater amount of Bound Water than Hatschek's method. In an earlier Paper II^{1b)}, the author has discussed the thermodynamic properties of water below 0.7 of " a " for the curves of the water-content " g "—water activity " a " for the common squid meat protein, cod meat protein, raw Atka mackerel meat and gelatine, which were determined by the vapour tension method at two different temperatures. The water-content—water-activity curve was discussed by Katz¹⁵⁾, Moran⁵⁾, Brooks¹⁶⁾ and Briggs¹⁷⁾ and recently by Higashi and Nukazawa^{2c)}, but it is difficult to decide what range of the curve indicates the boundary of Free and Bound Water, because the ideas respecting Bound Water are different from the standpoints of biology, colloidal chemistry and molecular theory respectively. However, as a characteristic of the curve of S shape, the water-content—water-activity curve has generally three parts, A, B, and C. The part of B is a gentle grade and its range is 0.2~0.7 of the value of " a ", that is to say, the variation of the water-content of the sample is small in the range of that water-activity. The parts A and C are steep grade; the range of part A is 1.0~0.7 of the values of " a " and that of part C is 0.2~0.0 of " a ".

In the discussion of Bound Water from the standpoint of molecular theory according to Herrmann, Gerngross and Abits¹⁸⁾ and Katz and Derksen¹⁹⁾ who have examined independently the molecular constitution of gelatine from the X-ray diffraction, and Sponsler, Bath and Ellis²⁰⁾ who have examined the hydration of amino acids which are components of gelatine, it is considered that 0.5 gm of the water-content per gm of dried gelatine is at least necessary to have a stable constitution of gelatine molecules. According to Adair and Callow²¹⁾, the amount of Bound Water is independent of the water-activity, and it takes a definite value of 0.5 per gm of dried matter. Briggs¹⁷⁾ stated that when the water-activity " a " is below 0.8~0.7, water corresponding to that water-activity does not act as a solvent. Recently Bull²²⁾ has examined the relation of water-content and water-activity of gelatine and other various high molecular compounds, and analyzed his results by the question of B.E.T.^{23a)}. He has considered the water of which the activity is below 0.7 of " a ", is the molecular theoretical Bound Water. Therefore, the present author has analyzed the thermal change in the water content " g "—water activity " a " curve obtained by vapour tension method by using the above stated samples. He has analyzed the same curve by the equation of B.E.T. of Brunauer *et al.*^{23a)} in order to learn whether the molecular theoretical Bound Water of protein is constituted of the molecules of water combined with the protein molecule through the hydrogen bond formation in a definite combining potential or not. From his experimental results, the author has ascertained that water below 0.7 of " a " in the curve of " g - a " should be the so-called molecular theoretical Bound Water on the basis of the idea of hydrogen bond formation.

In the present paper, the author has estimated the amount of Bound Water in raw fresh meat, dried meat, salted meat, fermented meat and decomposed meat of various kinds of fish by the cobaltous chloride method and by the electrical resistance method, and the results obtained will be described in following Section II.

Next, the author has studied the following subjects, and the results obtained were described in separated Sections:

Section III. The influence of Bound Water upon the drying velocity of fish meat.

Section IV. On the relation between the "Drip" formation and the amount of Bound Water during the refrigeration of fish meat.

Section V. The variation of the amount of Bound Water during salting of fish meat.

Section VI. On the relation between the amount of Bound Water and the decomposition of fish meat protein during the autolysis of fish meat.

ACKNOWLEDGEMENT

Before going further, the author wishes to express his hearty thanks to his respected teacher who suggested first this problem, Prof. Eiichi TANIKAWA, Faculty of Fisheries, Hokkaido University, for his sympathetic guidance and encouragement throughout these experiments and his kindness in reading and correcting this manuscript. Moreover, the author wishes to express his obligation to Professors Yukihiro NAKAMURA, and Yataro OBATA, Faculty of Agriculture, Hokkaido University, and to Dr. Masao MIGITA, Tokai Regional Fisheries Research Institute, for their helpful guidance and criticisms in regard to the problems discussed in his paper.

Further, acknowledgements are made to Prof. Ken-ichi HIGASHI, Research Institute of Applied Electricity, Hokkaido University and Prof. Kozo HIROTA, Faculty of Science, Osaka University, for their kind leading and valuable advice.

Lastly, the author wishes to express his thanks to Messrs. Terushige MOTOHIRO, Yutaka FUJII, Yoshio NAGASAWA for their kind aids in these experiments.

II. ESTIMATION OF THE AMOUNT OF BOUND WATER IN FISH MEAT IN VARIOUS CONDITIONS BY THE COBALTOUS CHLORIDE AND BY THE ELECTRICAL RESISTANCE METHODS

In this experiment, the amounts of Bound Water in raw fresh meat, dried meat, salted meat, fermented meat and decomposed meat of various kinds of fish were estimated by the cobaltous chloride method, and by the electrical resistance method.

1. Experimental methods

(1) The method of estimating the amount of Bound water

The method chosen for estimating the amount of Bound Water was Oyagi's^{14b)}. The calculation was carried out by the same method as described in the earlier Paper I, III. 1, (II, B)^{1a)}.

To calculate the amount of Bound Water (R.B, %) in the original samples (not dyed sample), the total amount of water (R.T, %) in the like same sample of each material was determined by the usual drying method.

The calculating formula is as follows:

$$R.B. = \frac{(100 - R.T.)(W_1 - W_2)}{W_2} \quad (1)$$

where, W_1 is the weight at the point where the colour of the dyed sample changes from pink to pure blue, or the apparent constant weight of the sample during the initial drying at 30°C, W_2 is the constant weight of the sample during the final drying at 110°C. The amount of Free Water (R.F. %) in the original sample, is calculated as follows:

$$R.F. = R.T. - R.B. \quad (2)$$

In this calculation, the amount of Bound Water per gm of the dried matter of the sample was supposed to remain unchanged during the steeping of the sample in 10% cobaltous chloride solution.

(2) The electrical resistance method

The estimating method by the electrical resistance was the same as in the previously described Paper I, III, 1, (1), (IV)^{1a}). The sample of fish meat fillet (4 × 2 × 2 cm) was impaled upon two copper poles (6.7 cm in length and 0.17 mm in diameter) fixed on the insulated bakelite plate at definite distance. The estimation of the electrical resistance was made by an apparatus manufactured by Fuji Radio Co., its cycle was 50, and its type was wheatstone's bridge. The estimating temperature was 17°C, and the drying temperature of fish meat was 19°C or 20°~25°C; the sample thrust through by the poles was placed in the desiccator before the estimation of electrical resistance.

2. Results and consideration

(1) Determination of the amount of Bound Water by Oyagi's method

The results on sandfish (*Arctoscopus japonicus* STEINDACHNER), squid (*Ommastrephes sloani pacificus*) and flat fish (*Kareius bicoloratus* BASILEWSKY) are shown in Table 1 and Fig. 1.

As stated in earlier Paper I, III, 1^{1a}), the sign B.P. in Table 1 and Fig. 1 is the point at which the colour of pieces of dyed fish meat steeped in the cobaltous chloride solution turns to pure blue from pink in the course of drying at 30°C. The amount of water estimated at point B.P. is represented as the amount of Bound Water. But as shown in the experiment there is another point, C.P., which is recognized as the apparent constant weight of the sample in the course of drying at 30°C from 1 to 3 hours after the appearance of the point B.P.

Discussing Bound Water from its binding strength, any amount of the water content determined by the cobaltous chloride method between the points B.P. and C.P. is regarded as the amount of Bound Water. The author, therefore, calls the amount of water at point B.P. the maximum value of the amount of Bound Water, and that amount at C.P. the minimum value of the amount of Bound Water. The amounts of Bound Water at those two points were estimated on the samples of various kinds of fish.

(i) Determination of the amount of Bound Water by the cobaltous chloride method on the raw fresh meat of various kinds of fish

The results derived from using Oyagi's method on the raw fresh meat of

Table 1. Variation in the amounts of water during the drying of various kinds of fish meats by the cobaltous chloride method (Oyagi's method)

Drying time in min.	Sandfish meat			Squid meat			Flat fish meat			
	Change of the weight of sample (gm)	g^* (gm)	Drying temp. ($^{\circ}$ C)	Change of the weight of sample (gm)	g^* (gm)	Drying temp. ($^{\circ}$ C)	Change of the weight of sample (gm)	g^* (gm)	Drying temp. ($^{\circ}$ C)	
0	0.1352	10.76	25° ~ 30°C	0.0641	5.04	25° ~ 30°C	0.0883	3.57	15° ~ 20°C	
30	0.0534	3.63		—	—		—	—		—
60	0.0418	2.63		—	—		—	0.0613		2.17
90	0.0319	1.77		—	—		—	—		—
120	0.0282	1.39		0.0242	1.28		0.0476	1.46		—
150	0.0265	1.30		0.0173	0.63 (B.P ₃)		—	—		—
180	0.0242	1.10		0.0138	0.30		0.0331	0.72 (B.P ₄)		—
210	0.0220	0.91 (B.P ₂)		0.0130	0.226		—	—		—
240	—	—		0.0120	0.132		0.0253	0.31		—
270	0.0196	0.70		0.0120	0.132(C.P ₃)		—	—		—
300	0.0195	0.69 (C.P ₂)	—	—	100°	0.0231	0.198	—		
330	0.0157	0.36	100°	0.0106	0.00	~	—	—		
360	0.0115	0.00	~	0.0106	0.00	105°C	0.0228	0.180(C.P ₄)		
370	0.0115	0.00	105°C	—	—	—	—	—		
420	—	—	—	—	—	—	0.0228	0.180	—	
480	—	—	—	—	—	—	0.0198	0.010	100°	
540	—	—	—	—	—	—	0.0193	0.00	~	
600	—	—	—	—	—	—	0.0193	0.00	105°C	
Remarks	II curve in Fig. 1			III curve in Fig. 1			IV curve in Fig. 1			

Note; I curve in Fig. 1 is the same curve as shown in Fig. 7, previous Paper I, Experiment III, 1^{1a}).

* g =Gm of water per gm of dried matter.

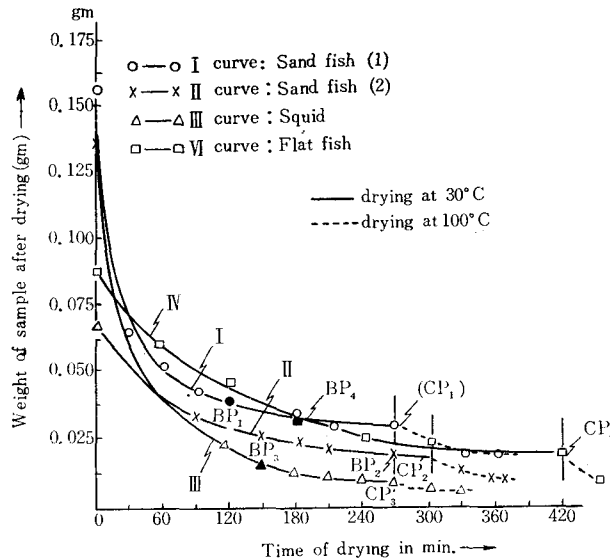

The amount of Bound water per gm of dried matter

0.67 (B.P ₁)	0.356 (C.P ₁)
0.91 (B.B ₂)	0.69 (C.P ₂)
0.63 (B.P ₃)	0.132 (C.P ₃)
0.72 (B.P ₄)	0.180 (C.P ₄)
at B.P (max.)	at C.P (min.)

Fig. 1. Variation in the amounts of water during the drying of various kinds of fish meats by the cobaltous chloride method (Oyagi's method)

squids (*Ommastrephes sloani pacificus* and *Doryteuthis bleekeri* KEFERSTEIN), flat fishes (*Microstomus achne* JORDAN et STARKS, *Atheresthes evermanni* JORDAN et STARKS, *Kareius bicoloratus* BASILEWSKY, *Limanda herzensteini* JORDAN et SNYDER and *Paralichthys olivaceus* TEMMINCK et SCHLEGEL), herring (*Clupea pallasii*), sardine (*Engraulis japonicus* TEMMINCK et SCHLEGEL), mackerel (*Scomber japonicus* HOUTTUYN), Atka mackerel (*Pleurogrammus azonus* JORDAN et METZ), horse mackerel (*Trachurus japonicus* TEMMINCK et SCHLEGEL), sand-fish (*Arctoscopus japonicus* STEINDACHNER) and globe-fish (*Spheroides rubripes* TEMMINCK et SCHLEGEL) are shown in Tables 2, 3, and 4. Table 2 shows the minimum values of the amount of Bound Water in the samples; Table 3 shows the maximum values of Bound Water; Table 4 shows the averages of those values of Bound Water per 100 gm of the dried matter of the samples.

From Table 4 it is clear that the minimum amount of Bound Water is 10~48 gm (24.4 gm on the average) per 100 gm of the dried matter, and the maximum amount of Bound Water is 55~82 gm (63.2 gm on the average). Supposing that Free Water has evaporated first when the raw fresh meat is dried, therefore, the total amount of water remaining in the fish meat is considered to be Bound Water at the time when the water-content of the meat shows

Table 2. Minimum values of the amount of Bound Water in the raw fresh meat of various kinds of fish

Samples	Water-contents	Total Water (R.T. %)	Free Water (R.F. %)	Bound Water (R.B. %)	$\frac{R.F.}{R.T.} \times 100$ (%)	$\frac{R.B.}{R.T.} \times 100$ (%)	"g" (gm of Bound Water per gm of dried matter)	$\frac{g}{g+D.M.} \times 100$ (D.M. = Dried matter)
Squid (<i>Ommastrephes sloani pacificus</i>)	(1)	83.51	81.43	2.18	97.50	2.50	0.132	11.6
	(2)	81.64	80.64	3.48	95.85	4.15	0.220	18.0
Squid (<i>Doryteuthis bleekeri</i> KEFERSTEIN)		79.89	70.26	9.60	88.00	12.00	0.477	32.3
Flat fish (<i>Atheresthes evermanni</i> JORDAN et STARKS)		80.99	79.28	1.71	97.87	2.13	0.09	8.25
Flat fish (<i>Kareius bicoloratus</i> BASILEWSKY)	(1)	79.19	74.51	4.66	94.11	5.89	0.224	18.3
	(2)	78.64	74.39	4.25	94.59	5.41	0.169	16.6
Flat fish (<i>Paralichthys olivaceus</i> TEMMINCK et SCHLEGEL)		78.02	73.30	4.72	93.90	6.10	0.215	17.7
Flat fish (<i>Microstomus achne</i> JORDAN et STARKS)		76.18	72.50	3.68	95.16	4.84	0.154	13.3
Herring (<i>Clupea pallasii</i>)	(1)	81.64	78.84	2.80	96.50	3.44	0.152	13.1
	(2)	80.62	76.70	3.92	95.13	4.87	0.202	16.6
Sardine (<i>Engraulis japonicus</i> TEMMINCK et SCHLEGEL)	(1)	76.55	71.80	4.37	93.80	6.20	0.202	16.6
	(2)	79.34	74.54	4.80	94.00	6.00	0.232	18.8
Sandfish (<i>Arctoscopus japonicus</i> STEINDACHNER)		80.30	73.30	7.00	91.28	8.72	0.356	26.2
Atka mackerel (<i>Preurogrammus azonus</i> JORDAN et METZ)	(1)	80.00	71.26	8.74	89.09	10.93	0.437	30.4
	(2)	83.95	80.47	3.48	95.85	4.15	0.216	17.8
	(3)	80.99	79.28	1.71	97.87	2.13	0.090	8.25

Table 3. Maximum values of the amount of Bound Water in the raw fresh meat of various kinds of fish

Samples	Water-contents	Total Water (R.T. %)	Free Water (R.F. %)	Bound Water (R.B. %)	$\frac{R.F.}{R.T.} \times 100$ (%)	$\frac{R.B.}{R.T.} \times 100$ (%)	"g" (gm of Bound Water per gm of dried matter)	$\frac{g}{g+D.M.} \times 100$ (%) (D.M. = Dried matter)
Squid (<i>Doryteuthis bleekeri</i> KEFERSTEIN)	(1)	76.27	59.03	17.24	77.3	22.7	0.726	42.0
	(2)	78.19	60.85	17.34	77.8	22.2	0.778	43.8
	(3)	78.73	59.56	19.17	75.6	24.4	0.896	47.2
	(4)	78.45	60.21	18.24	76.7	23.3	0.845	45.8
Squid (<i>Ommastrephes sloani pacificus</i>)		76.62	63.58	13.58	82.9	17.1	0.557	35.8
Sandrine (<i>Engraulis japonicus</i> TEMMINCK et SCHLEGEL)	(1)	76.70	65.66	11.04	85.6	14.4	0.474	32.1
	(2)	76.70	59.50	17.20	77.5	22.5	0.738	42.5
Sandfish (<i>Arctoscopus japonicus</i> STEINDACHNER)	(1)	80.51	67.40	13.11	83.7	16.3	0.678	40.2
	(2)	80.51	66.79	13.72	82.9	17.1	0.704	41.3
Horse mackerel (<i>Trachurus japonicus</i> TEMMINCK et SCHLEGEL)	(1)	76.14	57.60	18.54	75.7	24.3	0.777	43.7
	(2)	73.20	54.28	18.92	74.1	25.9	0.706	41.4
Grobe-fish (<i>Spheroides rubripes</i> TEMMINCK et SCHLEGEL)	(1)	80.07	68.97	11.10	86.1	13.9	0.557	35.8
	(2)	80.10	65.40	14.67	81.0	19.0	0.736	42.4
Flat fish (<i>Limanda herzensteini</i> JORDAN et SNYDER)	(1)	78.88	52.96	25.92	67.1	32.9	1.230	55.2
	(2)	78.74	54.99	23.75	69.8	30.2	1.117	52.8
Mackerel (<i>Scomber japonicus</i> HOUTTUYN)		76.62	63.58	13.04	82.9	17.1	0.557	35.8

Table 4. Amount of Bound Water in the raw fresh meat of various kinds of fish

Samples	Amount of Bound Water	Minimum amount of Bound Water*	Maximum amount of Bound Water*
Squid (<i>Ommastrephes sloani pacificus</i>)		17.5	55.7
Squid (<i>Doryteuthis bleekeri</i> KEFERSTEIN)		47.7	81.1
Sardine (<i>Engraulis japonicus</i> TEMMINCK et SCHLEGEL)		21.7	60.6
Sandfish (<i>Arctoscopus japonicus</i> STEINDACHNER)		35.6	68.8
Flat fish (<i>Kareius bicoloratus</i> BASILEWSKY)		21.1	—
Flat fish (<i>Microstomus achne</i> JORDAN et STARKS)		9.0	—
Flat fish (<i>Atheresthes evermanni</i> JORDAN et STARKS)		15.4	—
Flat fish (<i>Paralichthys olivaceus</i> TEMMINCK et SCHLEGEL)		21.5	—
Flat fish (<i>Limanda herzensteini</i> JORDAN et SNYDER)		—	54
Herring (<i>Clupea pallasii</i>)		17.5	—
Atka mackerel (<i>Pleurogrammus azonus</i> JORDAN et METZ)		37.1	—
Mackerel (<i>Scomber japonicus</i> HOUTTUYN)		—	55.7
Horse mackerel (<i>Trachurus japonicus</i> TEMMINCK et SCHLEGEL)		—	64.8
Globe-fish (<i>Spheroides rubripes</i> TEMMINCK et SCHLEGEL)		—	64.6
Range (Average)		10~48 (24.4)	55~82 (63.2)

* gm of Bound Water per 100 gm of dried matter.

about 20% (the minimum water-content) or 40% (the maximum water-content) in original material.

Higuchi¹²⁾ has estimated the amounts of Bound Water in squid and flat fish meat by a method concerning the depression of the freezing point and calorimetric method. The present author has calculated Higuchi's results as follows: the amount of Bound Water in squid is 13.4 gm per 100 gm of the dried matter of the sample, and 18.7 gm for flat fish meat. These values are in correspondence with the minimum values estimated by this cobaltous chloride method.

(ii) The amount of Bound Water estimated in the dried meat of several kinds of fish by the cobaltous chloride method

The maximum and minimum values of the amount of Bound Water of squids (*Ommastrephes sloani pacificus* and *Doryteuthis bleekeri* KEFERSTEIN), mackerel (*Scomber japonicus* HOUTTUYN), Atka mackerel (*Pleurogrammus azonus* JORDAN et METZ), sandfish (*Arctoscopus japonicus* STEINDACHNER), globefish (*Sphaeroides rubripes* TEMMINCK et SCHLEGEL), sardine (*Engraulis japonicus* TEMMINCK et SCHLEGEL) and flat fish (*Limanda herzensteini* JORDAN et SNYDER) by the cobaltous chloride method are shown in Tables 5 and 6.

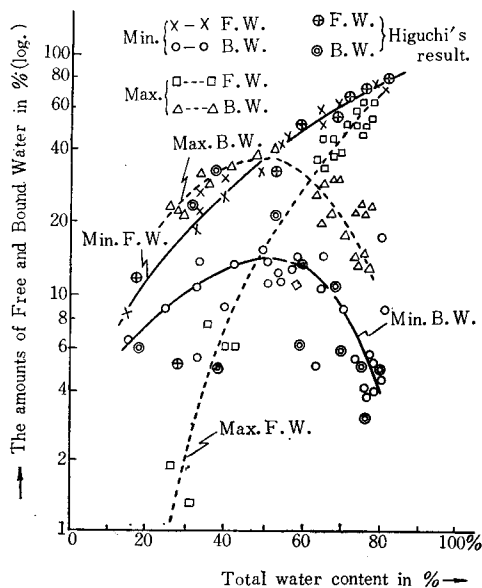

Fig. 2. Variation of the amounts of Free (F.W.) and Bound Water (B.W.) in the course of drying

Fig. 2 shows the relation between the total amount of water of each sample of various kinds of fish meat and the amount of Free Water, or the relation between the maximum and the minimum values of Bound Water of each sample.

Fig. 3 shows the amount of Bound Water per gm of the dried matter of each sample in relation to the total amount of water in each sample. The curves in Fig. 2 are formed by joining the massed points for the amounts of Free Water and Bound Water (the maximum and the minimum values) of all the samples. These curves are considered to show the variation of the amounts of Free and Bound Water during the drying of fish meat.

From Fig. 2 it is clear that with the drying, the percentage of the amount of Free Water decreases, while that of Bound Water increases relatively; the relative amount of Bound Water to the total amount of water shows the maximum at about 40~50% of the total amount of water in the fish meat. At this peak of Bound Water content, the percentage of the amount of Bound Water to the total

Table 5. Minimum values of the amount of Bound Water in the dried meat of various kinds of fish

Samples and Treatments	Water-contents	Total Water (R.T. %)	Free Water (R.F. %)	Bound Water (R.B. %)	$\frac{R.F.}{R.T.} \times 100$ (%)	$\frac{R.B.}{R.T.} \times 100$ (%)	"g" (gm of Bound Water per gm of dried matter)	$\frac{g}{g+D.M.} \times 100$ (%) (D.M.=Dried matter)
Squid (<i>Ommastrephes sloani pacificus</i>) (Sun-drying)	(1)	77.33	73.33	4.00	94.80	5.20	0.176	15.0
	(2)	74.64	69.11	5.53	92.59	7.41	0.218	17.9
	(3)	62.87	57.83	5.04	91.98	8.02	0.136	12.0
	(4)	38.53	26.48	12.05	68.72	31.28	0.196	16.4
	(5)	31.80	21.28	10.52	66.91	33.09	0.154	13.3
	(6)	31.74	18.10	13.64	57.02	42.98	0.199	16.6
	(7)	31.44	26.10	5.34	83.01	16.99	0.078	7.25
	(8)	14.58	8.38	6.20	57.47	42.53	0.073	6.82
Atka mackerel (<i>Pleurogrammus azonus</i> JORDAN et METZ) (Semi-dried)	(1)	79.17	74.51	4.66	94.11	5.89	0.224	18.3
	(2)	78.64	74.39	4.25	94.59	5.41	0.199	16.6
	(3)	77.51	69.50	5.01	86.67	10.33	0.356	27.0
	(4)	77.33	73.33	4.00	94.82	5.18	0.176	15.0
	(5)	76.18	72.50	3.68	95.16	4.84	0.154	13.3
	(6)	74.64	69.11	5.54	92.56	7.41	0.218	17.9
	(7)	69.00	60.29	8.71	87.37	12.63	0.281	21.9
Ditto (Sun-drying)	(1)	80.00	71.26	8.74	89.09	10.93	0.437	30.4
	(2)	64.90	54.16	10.74	83.45	16.55	0.306	23.4
	(3)	57.90	46.92	10.98	81.03	18.97	0.261	19.9
	(4)	55.90	43.47	12.45	77.76	22.24	0.282	21.9
Ditto (Drying by heating)	(1)	63.20	48.74	14.46	77.12	22.88	0.393	28.2
	(2)	40.50	27.35	13.15	67.53	32.47	0.221	18.1
	(3)	38.30	29.54	8.76	77.12	22.88	0.142	12.4
Ditto (Salting and Drying)	(1)	57.00	42.43	14.44	74.44	25.56	0.339	25.3
	(2)	55.00	41.64	13.33	72.33	27.67	0.269	21.2
	(3)	52.90	40.80	12.10	77.12	22.88	0.257	20.4
	(4)	49.30	35.66	13.64	72.33	27.67	0.269	21.2
	(5)	48.60	37.65	10.95	74.73	25.27	0.213	17.5
	(6)	47.60	32.99	15.51	67.41	32.59	0.296	22.9

Table 6. Maximum values of the amount of Bound Water in the dried meat of various kinds of fish

Samples and Treatment	Water-contents	Total Water (R.T. %)	Free Water (R.F. %)	Bound Water (R.B. %)	$\frac{\text{R.F.}}{\text{R.T.}} \times 100$ (%)	$\frac{\text{R.B.}}{\text{R.T.}} \times 100$ (%)	"g" (gm of Bound Water per gm of dried matter)	$\frac{g}{g+D.M.} \times 100$
								(D.M.=Dried matter)
Squid (<i>Doryteuthis bleekeri</i> KEFERSTEIN) (Sun-drying)	(1)	34.31	7.31	26.93	21.50	78.50	0.410	29.0
	(2)	26.42	1.84	24.58	6.96	93.04	0.334	25.0
	(3)	25.61	0.76	28.85	2.97	97.03	0.334	25.0
Mackerel (<i>Scomber japonicus</i> HOUTTUYN) (Semi-dried)	(1)	73.27	50.68	22.59	68.20	30.80	0.845	45.7
	(2)	73.38	50.21	23.17	68.40	31.60	0.873	46.6
	(3)	73.49	49.74	23.75	67.70	32.30	0.896	47.2
	(4)	64.95	43.75	21.20	67.30	32.70	0.605	37.8
Sandfish (<i>Arctoscopus japonicus</i> STEINDACHNER) (Sun-drying)	(1)	52.71	11.76	40.95	22.30	77.30	0.862	46.6
	(2)	28.57	5.15	23.42	18.02	81.98	0.328	24.7
Globefish (<i>Spheroides rubripes</i>) TEMMINCK et SCHLEGEL (Sun-drying)	(1)	39.47	5.82	33.65	14.70	85.30	0.556	35.7
	(2)	39.47	5.94	33.53	15.00	85.00	0.554	35.6
Squid (<i>Ommastrephes sloani pacificus</i>) (Semi-dried)	(1)	74.10	60.17	13.93	81.20	18.80	0.538	35.0
	(2)	73.50	58.93	14.57	80.10	19.90	0.550	35.4
	(3)	73.80	59.55	14.25	80.70	19.30	0.544	35.2
	(4)	70.10	51.26	18.85	73.10	26.90	0.603	37.6
	(5)	63.26	35.38	27.88	55.90	44.10	0.756	43.1
	(6)	66.68	43.99	22.64	65.90	34.10	0.681	40.2
Flat fish (<i>Limanda Herzensteini</i> JORDAN et SNYDER) (Semi-dried)	(1)	76.61	53.06	23.55	69.20	30.80	1.007	50.3
	(2)	68.55	37.98	30.57	55.40	44.60	0.972	49.3
	(3)	65.21	24.98	30.23	53.64	46.34	0.864	46.3
	(4)	66.88	36.80	30.50	54.39	45.61	0.921	47.9
Sardine (<i>Engraulis japonicus</i> TEMMINCK et SCHLEGEL) (Sun-drying)		31.76	1.26	30.50	3.96	96.04	0.447	30.9

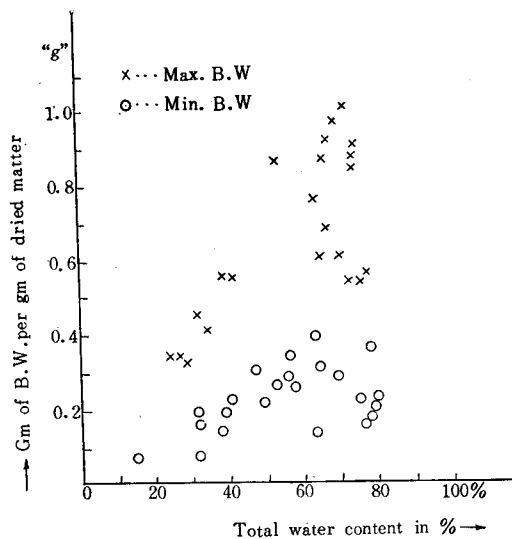

Fig. 3. Distribution of the absolute amount of Bound Water in the course of drying

amount of water in the fish meat shows from about 25% (minimum) to 75% (maximum) as seen in Tables 5 and 6. With further dehydration, the percentage of the amount of Bound Water decreases.

Higuchi's results for squid and flat fish meat during the drying which were together shown in Fig. 2 agreed generally with the minimum value of the amount of Bound Water obtained by the present author. It is interesting that the values of the amount of Bound Water obtained by the thermodynamic methods such as the one concerning the depression of the freezing point and the calorimetric method by Higuchi agreed almost with the results obtained by the chemical methods such as the cobaltous chloride method which is different from the thermodynamic methods in the idea of the determination. This agreement encourages the present author to believe that the minimum value of the amount of Bound Water obtained by the cobaltous chloride method (the amount of water at the point of C.P. in the course of drying of the sample) should be considered as the colloidal Bound Water. This conclusion has also been substantiated by the previously reported Experiment III, 1^{1a}).

From Fig. 3 the absolute amount of Bound Water per gm of the dried matter of the fish meat apparently decreases generally with the drying of the sample.

(iii) Results obtained by the cobaltous chloride method on the salted fish meat

Tables 7 and 8 show the amounts of Bound Water in the salted fish meat—Atka mackerel (*Pleurogrammus azonus* JORDAN *et* METZ), squid (*Doryteuthis bleekeri* KEFERSTEIN) and mackerel (*Scomber japonicus* HOUTTUYN).

Salted Atka mackerel meat was prepared by the dry-salting and brine-salting processes respectively. Salted mackerel and squid were made by dry-salting

Table 7. Variation of the minimum values of the amount of Bound Water in Atka mackerel meat at certain intervals after salting

Samples, Treatments and Days	Water-contents	Total Water (R.T. %)	Free Water (R.F. %)	Bound Water (R.B. %)	R.B. × 100		"g" (gm of Bound Water per gm of dried matter)
					R.T. (%)	R.F. (%)	
Atka mackerel (<i>Pleurogrammus azonus</i> JORDAN et METZ) (Brine-salting)	Raw fish meat	80.5	68.92	11.58	14.39	85.61	0.594
	3 days after	61.7	44.73	16.97	27.53	72.47	0.443
	5 "	62.8	50.52	12.28	19.56	80.44	0.330
	7 "	63.1	—	—	—	—	—
Ditto (Dry-salting)	Raw fish meat	80.5	68.92	11.58	14.39	85.61	0.594
	3 days after	61.1	47.18	13.92	22.88	77.12	0.358
	5 "	59.7	42.62	17.08	28.60	71.40	0.425
	7 "	42.4	20.80	21.60	59.95	49.50	0.375

Table 8. Variation of the maximum values of Bound Water in squid and mackerel meat at certain intervals after salting

Samples, Treatments and Days	Water-contents	Total Water (R.T. %)	Free Water (R.F. %)	Bound Water (R.B. %)	R.B. × 100		"g" (gm of Bound Water per gm of dried matter)
					R.T. (%)	R.F. (%)	
Squid (<i>Doryteuthis bleekeri</i> KEFERSTEIN) (Dry-salting)	Raw fish meat	78.45	60.21	18.24	23.26	76.74	0.845
	1 day after	62.52	33.73	29.79	46.05	53.95	0.795
	2 days after	61.94	14.41	47.53	76.74	23.26	1.249
	4 "	60.44	13.24	47.20	78.10	21.90	1.193
Mackerel (<i>Scomber japonicus</i> HOUTTUYN) (Dry-salting)	Raw fish meat	73.38	50.21	23.17	31.58	68.42	0.873
	1 day after	58.04	9.62	48.42	83.43	16.57	1.154
	2 days after	55.65	10.32	45.33	81.46	18.54	1.022
	4 "	57.94	26.68	31.30	53.99	46.01	0.745

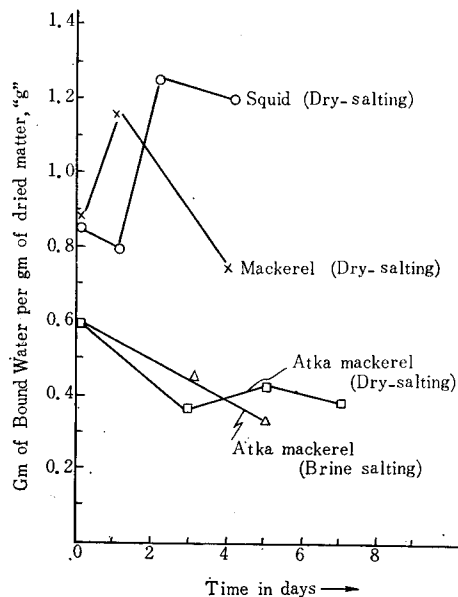

Fig. 4. Variation of the absolute amount of Bound Water in the course of salting

process. The amount of NaCl used was 20% by weight of the raw material in the dry-salting process. The brine used was saturated NaCl solution. The amounts of Bound Water in these salted fishes were determined by the cobaltous chloride method (Oyagi's).

Fig. 4 shows the variation of the absolute amounts of Bound Water in the salted Atka mackerel, squid and mackerel meat at certain intervals after salting.

In Table 7 the minimum values of Bound Water (at C.P.) for Atka mackerel meat were tabulated, while in Table 8 the maximum values of Bound Water (at B.P.) for mackerel and squid meat were tabulated.

From Tables 7 and 8, it is observed that the total amount of water decreases with the lapse of days after the salting process because of the osmotic dehydration by salt occurs. The dehydrating action of the dry-salting is greater than that of the brine-salting. This fact agrees with the previous results of many investigators²⁴).

During the salting of fish meat, the percentage of the amount of Free Water decreases, while that of Bound Water relatively increases; this fact agrees with the case of the dried fish meat.

However, the absolute amount of Bound Water in the Atka mackerel meat per gm of the dried matter decreased somewhat with the lapse of days after the salting, as shown in Fig. 4. This fact is perhaps due to the dissolution of fish meat protein or to the denaturation of the protein by the salting.

In the case of squid and mackerel meat the decrease in the absolute amount of Bound Water is not so clear as observed in Atka mackerel meat as shown in Fig. 4.

(iv) Results of estimations of the amount of Bound Water in fermented fish meat and decomposed fish meat by the cobaltous chloride method

(A) Variation of the amount of Bound Water in soused-squid meat ("Shiokara" in Japanese) during its ripening

The variation of the amount of Bound Water in soused-squid meat was observed as follows:

Soused-squid meat ("Shiokara") is a Japanese special product which is made from cut squid meat, its liver, and salt (sodium chloride). The author has prepared it by the following process. The body of fresh squid (average weight of a squid is 284 gm) was cut in small rectangular pieces (0.5 × 3 cm), and was mixed with NaCl and squid liver, then was stirred every day for 4 weeks. The amount of NaCl added was 15% by weight of the cut squid meat. The amount of squid liver added was 3% (A), and 6% (B), respectively by weight, of the cut squid meat.

The amount of Bound Water in the soused-squid meat was estimated by the cobaltous chloride method (Oyagi's method) after washing the surface of the cut squid meat and absorbing the water attached to the surface of the meat.

The variation of the amount of Bound Water during the ripening of soused-squid ("Shiokara") is shown as (A) and (B) in Table 9. The values there tabulated are the minimum amounts of Bound Water (at C.P.).

From Table 9 (A), (B), it is observed that the total amount of water increased gradually with the decomposition of fish meat protein by enzymic action for the first 10 days, and then that amount decreased as a manifestation of the effect of dehydrating action. In the total amount of water, the amount of Free

Table 9. Variation of the minimum amount of Bound Water during the ripening of soused-squid meat ("Shiokara")

(A) Squid liver added in 3%						
Days of processing	Total Water (R.T. %)	Free Water (R.F. %)	Bound Water (R.B. %)	$\frac{R.F.}{R.T.} \times 100$ (%)	$\frac{R.B.}{R.T.} \times 100$ (%)	"g" (gm of Bound Water per gm of dried matter)
0	82.63	79.38	3.25	96.06	3.94	0.187
4	85.66	82.95	2.71	96.83	3.14	0.189
7	89.00	97.38	1.62	98.17	1.83	0.147
10	82.44	82.01	0.43	99.47	0.53	0.024
21	87.46	87.22	0.24	99.72	0.28	0.019
(B) Squid liver added in 6%						
0	82.63	79.38	3.25	96.06	3.94	0.187
4	88.54	85.84	2.70	96.95	3.05	0.232
7	89.03	86.63	2.40	97.30	2.70	0.219
10	81.15	80.09	1.06	98.69	1.31	0.056
21	82.17	82.20	0.97	98.81	1.19	0.054

Water increased gradually and that of Bound Water decreased. This fact is contrary to the results obtained with the dried fish meat or the salted fish meat. The absolute amount of Bound Water per gm of the dried matter of the fermented fish meat decreased during the ripening. But this amount was observed to increase contrarily during the incipient ripening of fish meat. This fact will be understood that the dried matter of fish meat decreases owing to the decomposition of fish meat protein, but the amount of Bound Water is hardly influenced. However, this consideration is somewhat doubtful because of the supposition that the amount of Bound Water did not vary during the steeping of the sample in cobaltous chloride solution. It is certain that the variation of the amount of Bound Water in the fermented squid meat is different from that in either the dried fish meat or the salted fish meat.

(B) Variation of the amount of Bound Water in the decomposed Atka mackerel meat during the putrefaction

Semi-dried Atka mackerel meat (total water-content, 69%) was left to the time of detecting tainted odour in the Petri dish at 30°C, and the variation of the amount of Bound Water during the putrefaction was observed. The experimental results are shown in Table 10.

Table 10. Variation of the minimum amount of Bound Water in the decomposed Atka mackerel meat during the putrefaction

Days of processing	Total Water (R.T. %)	Free Water (R.F. %)	Bound Water (R.B. %)	$\frac{R.F.}{R.T.} \times 100$ (%)	$\frac{R.B.}{R.T.} \times 100$ (%)	"g" (gm of Bound Water per gm of dried matter)
0	69.0	60.29	8.71	87.37	12.63	0.281
2	69.4	62.24	7.16	89.68	10.32	0.237
6	74.2	67.39	6.81	90.82	9.18	0.264

As shown in Table 10, when the muscle tissue of fish decomposed with the putrefaction, the total amount of water increased gradually, and the tainted odour was noticeable already a day after the handling. It was observed that the amount of Free Water increased, while that of Bound Water decreased with the putrefaction of fish meat. This fact is similar to that obtained in the fermented squid meat. However, the variation of the absolute amount of Bound Water per gm of the dried matter of the sample is not clear.

In this experiment employing the cobaltous chloride method, the estimation was very difficult owing to the softening of fish meat; estimation was made again by the electrical resistance measurement. The vapour tension method was also applied for estimating the amount of Bound Water in the putrefied fish meat, but this method was not satisfactory, because the volatile basic matters grew from the meat.

(2) *Results of estimations by the electrical resistance method on some fish meat*

Ueda, Ito and Nishi^{25a)} and Tamura^{25b)} have observed the variation of the

electrical resistance in the fresh carp meat after the death. They stated that the electrical resistance decreased rapidly at a definite time after the death, and the lower the temperature is, the longer the time needed to decrease electrical resistance. The cause of the decreasing of electrical resistance is perhaps due to the change of the muscle tissue of fish meat by autolysis and bacterial action. Yamamura^{25c)} has observed that the specific electrical resistance of the direct current is 2,400~3,000 Ohms and of the alternating current of 1,000 cycles is 80~90 Ohms for the raw fresh meat of horse mackerel (*Trachurus japonicus* TEMMINCK *et* SCHLEGEL), mackerel (*Scomber japonicus* HOUTTUYN) or flat fish (*Limanda herzensteini* JORDAN *et* SNYDER). Tamura, Miyazaki and Kaziyama^{25d)} have studied the relation between the penetrated amount of NaCl into fish meat and the electrical resistance in the salted fish meat. Callow^{25e)} has also studied the electrical resistance of the muscular tissue of farm-killed pigs and of pigs killed in factory or abattoir. Recently Yamada and Kitano^{25f)} have studied variation of the electrical resistance and of pH value of the denatured myosin added with NaCl. Ito, Kyojuka and Sugizaki^{25g)} have also studied the electrical resistance of raw fresh fish meat, heated fish meat and chilled fish meat.

The present author has studied in his earlier Paper I, Experiment III, 1^{1a)}, the variation of the electrical resistance at 50 cycles in sample of gelatine and fish meat having various water-contents, and has obtained following results: the electrical resistance decreased somewhat with the initial decreasing of water-content, but it increased gradually at point above a definite dryness, and thereafter it increased rapidly. The gradual increasing of the electrical resistance at above a definite dryness was considered to be due to the increasing of the amount of Bound Water in inverse proportion to the decreasing of the Free Water. The rapid increasing in the next stage was considered to be due to the increasing of the binding strength of the Bound Water remained.

The amount of water estimated at point of rapid increasing of the electrical resistance was considered to be colloidal Bound Water as compared with the results obtained by the cobaltous chloride and vapour tension methods.

Here, the author reports the results obtained by estimating the electrical resistance for some fish meat.

(i) Preliminary experiment

(A) Relation between the electrical resistance (50 cycles) and the distance of electrodes for various kinds of fish meat

Table 11 and Fig. 5 show the relation between the electrical resistance at 50 cycles and the distance of the electrodes for various kinds of fish meat. In Fig. 5, the results obtained by Yamamura^{25c)} are written together. It was observed that the electrical resistance was proportional to the distance of electrodes and showed liner function. This result agrees with that obtained by Yamamura, but it was contrary to the result of Ito, Kyojuka and Sugizaki^{25g)}.

The electrical resistance of unfresh raw or chilled Atka mackerel meat is less than that of fresh raw Atka mackerel meat. This result agrees with the results obtained by Tamura^{25b)}. In salted Atka mackerel meat, the electrical resistance decreased with the penetration of the electrolyte (NaCl).

Table 11. Relation between the electrical resistance at 50 cycles and the distance of the electrodes for various kinds of fish meat

Samples Dist. of electrodes	Whole body of a species of Surf-smelt	Fesh raw Atka mackerel meat	Chilled Atka mackerel meat	Salted Atka mackerel meat	Unfresh raw Atka mackerel meat	Fresh raw squid (<i>Dory- teuthis blee- keri</i>) meat
1.5 cm.	0.395 K Ω	0.266	—	—	0.162	0.77
2.0	0.400	—	—	0.030	0.178	1.11
2.5	0.530	0.363	—	—	—	1.25
3.0	—	—	0.063	0.040	0.194	—
3.5	—	—	—	0.048	0.228	1.45
4.0	—	0.455	—	—	—	—
4.7	—	—	—	—	0.268	2.00
5.0	0.655	0.540	—	0.050	—	—
5.4	—	—	0.075	—	0.298	—
6.0	0.780	0.576	—	0.060	0.305	—
6.9	—	0.700	—	—	0.332	—
8.0	—	0.735	0.083	—	0.378	—
9.0	—	0.870	—	—	0.453	—
10.0	—	0.950	0.105	—	0.485	—
Remarks	Water- content 75.8%			Water- content 70.2% NaCl 15.7%		

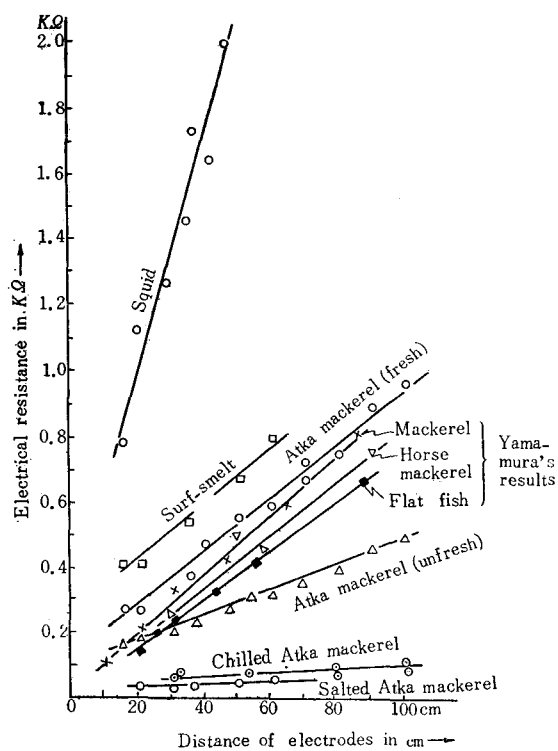

Fig. 5. Relation between the electrical resistance at 50 cycles and the distance of electrodes for various kinds of fish meat (Temp., 15°~16°C)

(B) The electrical resistance of fish meat gruel

After the method employed by Tamura^{25b}), the present author ground 100 gm of raw fresh meat of Atka mackerel and filtered it through gauze. This filtered meat was added with 200 c.c. of distilled water and made into fish meat gruel. It was separated in two parts: (A) Antiseptized gruel with toluene, (B) Non-antiseptized gruel. The electrical resistance of these two samples was estimated in a glass desiccator for several days.

The electrodes used were two platinum black plates 2 × 2 cm in size. They were fixed keeping them at a distance of 3 cm from each other in fish meat gruel. The specific electrical resistance was not estimated, but the apparent electrical resistance was estimated. The results are as shown in Table 12.

Table 12. Variation in the electrical resistance of fish meat gruel
(Atka mackerel meat) at certain intervals

Time (hrs.)	0	15	21	63	87	111	135	159	183	231
Processing										
(A) Antiseptized gruel by toluene	160	160	155	185	180	170	170	175	170	170
(B) Non-antiseptized gruel	160	160	150	160	150	150	150	145	150	150
Remarks	pH { A. 6.3 B. 6.6	6.3 6.6	— 6.4							pH { A. 6.4 B. 6.8

The electrical resistance of two samples (A) and (B) almost did not vary with the lapse of time after the handling. This result agrees with the results obtained by Tamura^{25b}).

From the result obtained, it was considered that the depression of the electrical resistance observed in the unfresh fish meat in previous section (A) is not due to the increasing of the amount of the soluble matter by the autolysis of fish meat or the decomposition of meat protein by bacteria, but that it is due to the destruction of muscle tissue of the meat.

(C) The relation among the water-content in the putrefied fish meat, the electrical resistance and the distance of the electrodes

From the previous two experiments, it was observed that the electrical resistance decreased with the destruction of the muscle tissue of fish meat.

Here, the present author has undertaken to study the relation among the water-content in the fish meat putrefied in the incipient drying, the electrical resistance and the distances of the electrodes.

The samples used were fresh raw Atka mackerel meat fillet (11×1.5×1.0 cm) and the whole body of a species of surf-smelt (*Hypomesus japonicus*), (10 gm in weight, 13 cm in length).

The distance between the electrodes was 1.5 to 10 cm.. The electrical resistances were observed for the samples two times in the incipient drying, and were observed thereafter for the putrefied samples which were laid in the Petri dishes at 30°C and began to have tainted smell. The putrefaction of fish meat

was determined by Amano's $\text{HgCl}_2^{26)}$ reaction. The electrical resistance of those samples was estimated at various water-content during the air-drying. The estimation of the electrical resistance for the whole body of surf-smelt was carried out as follows: two electrodes were thrust through into the center part of fish body between the body surface and back bone at the lateral line, and the electrical resistance was estimated at various distances of electrodes.

The experimental results are shown in Tables 13 and 14. The average value of three samples is tabulated. The relation between the electrical resistance and the distance of electrodes is illustrated in Fig. 6, and the relation among the

Table 13. Relation among the water-contents in the putrefied Atka mackerel meat, the electrical resistance (50 cycles) and the distance of electrodes

Distance of electrodes (cm) \ Water-content (%)	1.5	2.0	3.0	3.7	4.7	5.4
	<i>KΩ</i>					
75.0	0.163	0.178	0.194	0.228	0.268	0.298
72.6	0.176	0.167	0.218	0.258	0.295	0.331
70.0	0.208	0.238	0.256	0.296	0.325	0.371
60.4	0.141	0.154	0.234	0.236	0.285	0.344
50.3	0.141	0.217	0.345	0.410	0.479	0.563
Distance of electrodes (cm) \ Water-content (%)	6.1	6.9	8.0	9.0	10.0	Remarks
75.0	0.305	0.330	0.378	0.453	0.485	Drying
72.6	0.363	0.376	0.416	0.448	0.495	"
70.0	0.402	0.427	0.498	0.546	0.605	"
60.4	0.366	0.442	0.507	—	0.757	(Putrefied)
50.3	0.656	0.503	0.979	1.393	1.550	Drying

Table 14. Relation among the water-contents in the putrefied meat of a species of surf-smelt (whole body), the electrical resistance (50 cycles) and the distance of electrodes

Distance of electrodes (cm) \ Water-content (%)	1.5	2.0	3.5	5.0	6.0	Remarks
	<i>KΩ</i>					
75.4	0.390	0.380	0.535	0.663	0.813	Drying
72.5	0.390	0.415	0.550	0.738	0.825	"
69.4	0.430	0.502	0.728	0.988	1.240	"
64.7	0.336	0.393	0.638	0.913	1.192	(Putrefied)
55.7	0.421	0.457	0.866	1.373	2.085	Drying
40.3	0.640	0.817	1.618	5.325	30.533	"
25.0	1.708	2.255	43.25	778	8,000 over	"

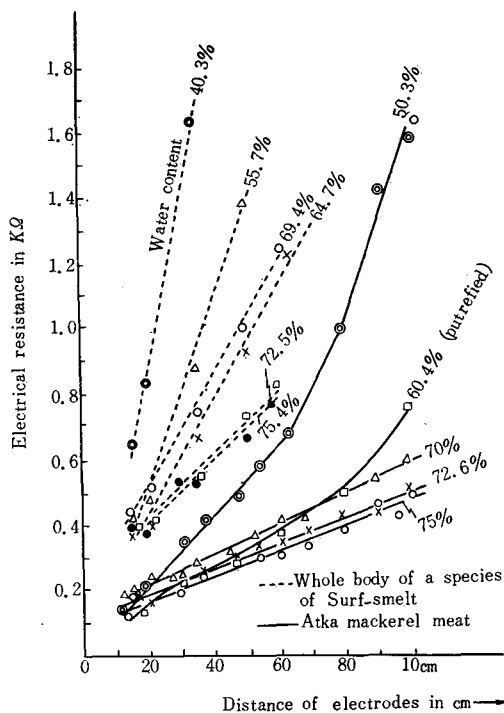

Fig. 6. Relation among the electrical resistance (50 cycles), the distance of the electrodes and the total water-contents in fish meat in various conditions

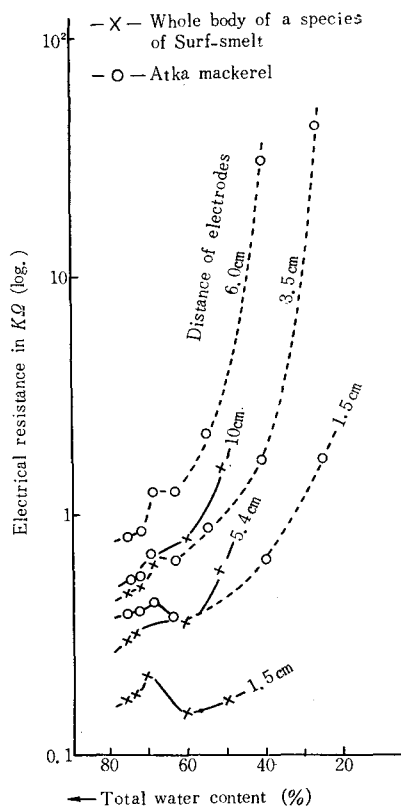

Fig. 7. Relation among the water contents in the putrefied fish meat, the electrical resistance and the distance of the electrodes

electrical resistance, the water-content and the distance of electrodes is illustrated in Fig. 7.

From Table 13 and Fig. 6, it was observed that the relation between the electrical resistance of Atka mackerel meat and the distance of the electrodes was a linear function, and with the drying of meat the straight line slipped off upwards. But the electrical resistance of the completely putrefied Atka mackerel meat (water-content 60.4%) depressed temporarily with the decreasing of water content and no linear function was observed, as if this result was inconsistent to the raw fish meat as above described. This fact is perhaps due to the destruction of the muscle tissue of the fish meat. But the electrical resistance increased with the progressive drying of the putrefied fish meat. Then the straight line showing the relation between the electrical resistance and the distance of electrodes slipped off upwards. At excessive drying, the electrical resistance increased logarithmically as indicated in Fig. 7.

As observed in Atka mackerel meat, the straight line showing the relation

between the electrical resistance of surf-smelt and distance of electrodes slipped off upwards with the drying. The electrical resistance of the putrefied fish meat also decreased temporarily with the decreasing of the water-content, then it increased logarithmically with the drying.

The electrical resistance of dried fish meat without putrefaction could be estimated. However, supposing from Figs. 6 and 7 showing the comparison of the curves of electrical resistance at the beginning of drying with after the putrefaction, the curve of the electrical resistance of the fish meat dried from fresh raw meat without putrefaction, perhaps slips off left side from the curve of the electrical resistance of the putrefied meat. As stated in earlier Paper Experiment III, 1^{1a}), if the rapid ascending of the curve of the electrical resistance in the lower water-content is due to the existence of the Bound Water having a certain degree of binding strength with fish meat protein, the fact that the rapid ascending point of the curve obtained from the putrefied fish meat was indicated in the lower water-content than in the fresh raw fish meat is perhaps due to the decreasing of the amount of Bound Water or to the weakening of the binding strength of it owing to the destruction of muscle tissue of fish meat.

- (ii) Results of observations of the electrical resistance at 50 cycles in fresh meat, salted meat and putrefied meat of Atka mackerel at various water-contents

In this experiment, use was made of fresh raw Atka mackerel meat ($8 \times 1.8 \times 1.0$ cm), putrefied Atka mackerel which has a slight putrefied smell in incipient drying and in the same size, and brine-salted Atka mackerel meat which has been immersed in saturated NaCl solution for 5 hours. The distance between the electrodes was 1.5 cm. The observed results of the electrical resistance at 50 cycles at various water-contents are shown in Tables 15 and 16. The results on the amount of Bound Water for the same samples by the cobaltous chloride method are also shown in the same Tables. The results shown in Tables 15 and 16 were obtained in the case of drying at 19°C and 20°~30°C respectively.

The estimating temperature of the electrical resistance were made for all the sample at 17°C. Fig. 8 was derived by plotting the results in Tables 15 and 16.

From Fig. 8 it is observed that the electrical resistance of the raw fresh Atka mackerel meat decreased with the initial decreasing of the total amount of water-content during the drying of the fish meat at 19°C, and then it increased gradually at near the water-content at the point B.P. which indicates the blue change point by the cobaltous chloride method (Oyagi's method), and then it increased rapidly at the point of C.P. which indicates the constant weight of the sample during the drying at 30°C by that method. The results obtained from the electrical resistance of two samples of the Atka mackerel meat dried at 20°~30°C are shown as almost the same curves.

The electrical resistance of the meat dried at 20°~30°C was larger than that of the meat dried at 19°C at the same water-content in the range of the total water-content of 60~20%, that is, the higher the drying temperature is, the smaller the electrical resistance is.

Such a difference of the electrical resistance was considered to be caused by the difference of drying temperatures, because the estimating temperature of

Table 15. Relation between the electrical resistance (50 cycles) and the water-contents in fresh, salted and putrefied Atka mackerel meat
(Drying temp., 19°C)

Fresh raw meat (A)		Salted meat (D)		Putrefied meat (F)		Putrefied meat (continue)	
Total Water (%)	Electrical Resistance (KΩ)	T.W. (%)	E.R. (KΩ)	T.W. (%)	E.R. (KΩ)	T.W. (%)	E.R. (KΩ)
79.6	0.45	70.2	—	79.1	0.455	15.1	50.0
70.3	0.41	64.2	0.035	74.0	0.340	14.5	135.0
48.4	0.45	55.2	0.045	68.6	0.450	14.0	160.0
38.2	0.65	52.0	0.049	60.9	0.400	12.9	279.0
24.5	5.50	45.6	0.060	49.6	0.420	12.4	300
20.2	60	40.0	0.110	37.4	0.500	10.2	7,000
14.8	1,000 over	31.0	0.260	29.4	1.23	—	—
—	—	21.2	65.0	17.0	3.23	—	—
Total Water	79.6%	Total Water	70.2%	Total Water	79.1%		
Free Water	60.0%	Free Water	46.3%	Free Water	68.6%		
at B.P ₁ { Bound Water		at B.P ₂ { Bound Water		at B.P ₃ { Bound Water			
{ (g)*	19.6% (0.961)	{ (g)*	23.9% (0.808)	{ (g)*	10.5% (0.503)		
at C.P ₁ (g)*	(0.372)	at C.P ₂ (g)*	(0.358)	at C.P ₃ (g)*	(0.280)		
		Ash content	16.6%**				
		NaCl content	15.7%**				

* g=gm of Bound Water per gm of dried matter.

** =% in dried matter.

Table 16. Relation between the electrical resistance (50 cycles) and the total water-contents in fresh and salted Atka mackerel meat
(Drying temp., 20°~30°C)

Fresh raw meat (B)		Fresh raw meat (C)		Salted meat (E)	
Total Water (%)	Electrical Resistance (KΩ)	T.W. %	E.R. (KΩ)	T.W. %	E.R. (KΩ)
78.8	0.60	78.4	0.52	70.7	—
70.2	0.45	71.6	0.40	52.0	0.050
61.7	0.47	64.8	0.38	49.6	0.065
54.1	0.60	60.9	0.46	48.4	0.070
43.1	0.95	50.2	0.72	45.6	0.075
34.6	1.00	43.9	1.50	44.3	0.120
28.2	4.20	30.5	1.60	39.1	0.130
20.9	8.50	27.1	8.00	33.5	0.220
18.0	70.0	25.8	18.0	25.4	0.66
17.4	360	21.9	70	22.1	1.35
16.8	700	17.4	1,000	20.2	76
12.8	6.500	—	—	16.6	270
—	—	—	—	14.7	3,000
—	—	—	—	11.45	8,000

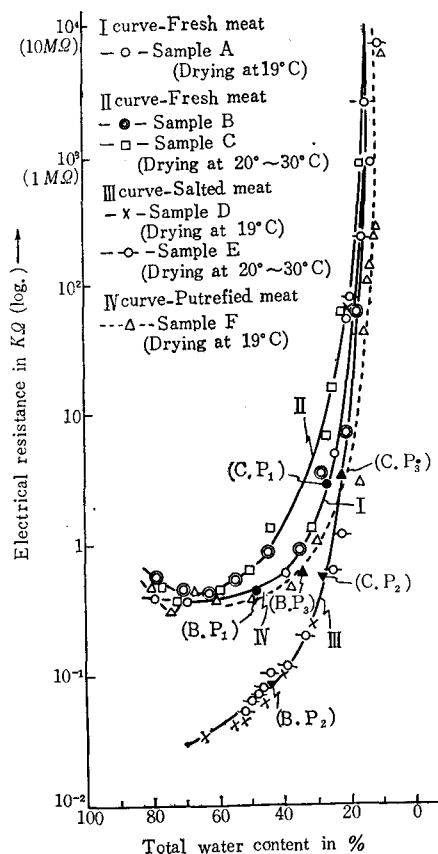

Fig. 8. Relation between the electrical resistance and the water-contents in fresh, salted and putrefied Atka mackerel meat

electrical resistance was the same after the maintenance of the samples in the desiccator at 17°C for some time.

As one of factors, pH influences the value of electrical resistance of the samples. The electrical resistance shows generally the maximum value at the isoelectric point of muscle protein. However, the value of pH of the fish meat is not considered to vary so much with the difference of the drying temperatures which were employed in this experiment (the average difference of temperature is 5°C). The electrical resistance may better be considered to be affected by the difference of the construction of muscle tissues originated by the drying temperatures. The muscle tissue of the fish meat dried at 19°C is rather homogeneous and fine, since the evaporation of water from the meat surface was considered to be slow, but the muscle tissue dried at $20^{\circ}\sim 30^{\circ}\text{C}$ has some gaps because of the more rapid evaporation. Therefore the electrical conductivity decreases and the electrical resistance increases in the fish meat dried at higher temperature. But,

the ascending of the curve of the electrical resistance of the sample dried at 20°~30°C agrees with the sample dried at 19°C at below 20% of the total water-content, so it is supposed that there is rather little change of the amount of Bound Water in the two samples of fish meat dried at 19°C and 20°~30°C.

In the putrefied fish meat, the property of the curve of the electrical resistance of the sample is the same as in the raw fresh meat. The electrical resistance began to increase at the water-content of the point of B.P₃ by the cobaltous chloride method, and increased rapidly at the point of C.P₃. However, the curve of the putrefied fish meat slips wholly away from the curve of the raw fresh fish meat as expected from the preliminary experiment. Therefore, the values of electrical resistance of the putrefied fish meat were lower than those of the raw fresh meat in comparison with the same water-content. Furthermore the amount of Bound Water of the putrefied fish meat at the points of B.P₃ and C.P₃ was less than that of the raw fresh fish meat at B.P₁ and C.P₁. This fact perhaps shows the decreasing of Bound Water in the meat owing to the decomposition or destruction of the muscle tissue.

In the salted fish meat, no remarkable difference was observed in the electrical resistance of the samples dried at 19°C or at 20°~30°C. The salted fish meat contains NaCl as the electrolyte (about 16% of the dried matter of the sample). Its electrical resistance, therefore, is less than that of the raw fresh fish meat in the beginning of the estimation, but it increased rapidly during the drying, and at last the ascending of the curve agreed almost with the curve of the raw fresh meat.

As to the concentration of NaCl in the fish meat, such amount of NaCl, 16% per dried matter as above stated is enough to the ability of osmotic dehydration, therefore, a part of water which has weak binding strength with fish meat protein hydrates with NaCl, and less amount of Bound Water remains with the strong binding ability in the fish meat protein. Consequently, the electrical resistance was considered to increase rapidly by the existence of such Bound Water remained in the course of the drying.

(3) *Conclusions as to the results of estimations of the amounts of Bound Water in the various states of meat of various kinds of fish by the cobaltous chloride method and by the measurement of the electrical resistance*

The author has estimated the amount of Bound Water in the meat of various kinds of fish by the cobaltous chloride method (Oyagi's method)^{14b)} and by the measurement of the electrical resistance, and the following results and considerations were obtained.

(1) The amounts of Bound Water in the fresh raw meat of 14 kinds of fish were estimated; they differed with the kind of fish and individual bodies used, but it was recognized that the maximum amount of Bound Water is 55~82 gm, the minimum amount of Bound Water is 10~48 gm per 100 gm of the dried matter of the sample.

(2) The absolute amount of Bound Water per dried matter of fish decreased during the drying of fish meat. In this case, the amount of Free Water in the total amount of water in fish meat decreases from the beginning with the

drying of the meat. But the amount of Bound Water increased reciprocally to the decreasing of the amount of Free Water accompanying with the initial decreasing of the total amount of water in fish meat. The maximum value of the amount of Bound Water is observed at 40~50% of the total amount of water in fish meat, and then the amount of Bound Water decreased with the progressing of the drying of fish meat.

(3) The total amount of water in fish meat decreased somewhat by osmotic dehydration during the salting. In this case, the amount of Free Water also decreased, but that of Bound Water increased reciprocally. However, the change of the absolute amount of Bound Water per gm of the dried matter was not clearly recognized since some loss of dried matter caused by dissolving of soluble protein occurs as an accompanying phenomenon. But, the absolute amount of Bound Water is considered generally to decrease.

(4) In the case of the decomposition of fish meat, *e.g.*, in the putrefaction or in the fermentation of squid meat (Soused squid meat), it was observed that the total amount of water increased gradually, and the amount of Free Water increased also, while that of Bound Water decreased reciprocally. These results were observed to be different from the results influenced by dehydration during the drying or salting. But in this case, the change of the absolute amount of Bound Water was not clearly recognized by the cobaltous chloride method.

(5) During the autolysis or the putrefaction of fish meat, the electrical resistance decreased rapidly. This fact is considered to be due to the destruction of the muscle tissue of the fish meat. And it was also considered that the larger the amount of Bound Water in fish meat was, the higher the electrical resistance was. From this consideration, the amount of Bound Water was considered to decrease with putrefaction.

(6) From the estimated results of the electrical resistance at various water-contents in the fresh raw fish and salted fish meat, it was supposed that when a large amount of NaCl penetrates into the fish meat, a part of the amount of Bound Water, except Bound Water possessing strong combining strength, hydrates with NaCl penetrated.

III. THE INFLUENCE OF BOUND WATER UPON THE VELOCITY OF DRYING OF FISH MEAT

As stated in a previous article, Higuchi¹²⁾ has estimated the amounts of Bound Water in squid and flat fish meat. When samples of those fish meats were dried, the amount of Free Water decreased and that of Bound Water relatively increased with the decreasing of the total amount of water.

The present author has also studied the distribution of the amount of Bound Water in the raw or dried meat of various kinds of fish as described in the previous Section II. According to his results, the proportion of the amount of Bound Water to the total amount of water in those fish meats indicated 30% (minimum)~95% (maximum) in the range of 50~15% of the total amount of water-content.

The fact that those values of amount of Bound Water in the dried fish meats are much larger than those of the fresh raw fish meat indicates that when fish meat is drying, the amount of Free Water at first decreases while that of Bound Water increases relatively.

On the physical problems concerning the drying of fish meat, Fujiwara, Tsuda and Yasui²⁷⁾, Inoue²⁸⁾, and recently Kawakami²⁹⁾ have studied and discussed various aspects. In general, drying period of common granular solid matter, e.g. sand or clay, may be divided clearly into three stages: (1) the period of constant rate of drying, (2) the period of first stage of falling rate of drying and (3) second stage of the same. In the drying of fish meat, e.g. in the case of washed fish meat or fish meat moistened with water which has a thin layer of water regarded as a true free water, as long as this thin layer of water continues to evaporate, the period of constant rate of drying may be admitted. However, in the case of drying of fish meat having no thin layer of water in the surface it is considered that already in the initial of drying of fish meat, the mechanisms of drying corresponds to the period of first stage of falling rate of drying stage. This period of first stage of falling rate of drying appears to continue to the last of the drying without clear difference between the first stage and second stage of falling rate of drying, because of the hydrophilic properties of fish protein. Kawakami²⁹⁾ has pointed out that the amount of Bound Water in the fish meat has important influence upon the mechanism of drying.

The present author has estimated the amount of Bound Water in the various kinds of fish muscle by means of the vapour tension method and the cobaltous chloride method; he offers a discussion of the thermodynamic properties of water in the fish meat having various amounts of water-content. He has also determined the drying curve of fish meat at the low drying temperatures (35°~40°C), and discussed the influence of the amount of Bound Water upon the velocity of drying.

1. Experimental part

(1) Samples

As samples, 12 kinds of fish, mollusc and crustacean were employed, such as crucian carp (*Carassius auratus* (LINNE)), "Soi" in Japanese (a kind of gray rock cod) (*Sebastichthys trivittatus* (HIRGENDORF)), yellow-tail (*Seriola quinqueradiata* TEMMINCK et SCHLEGEL), Atka mackerel (*Pleurogrammus azonus* JORDAN et METZ), sardine (*Sardinia melanosticta* (TEMMINCK et SCHLEGEL)), mackerel (*Scomber japonicus* HOUTUYN), tuna (*Thunnus orientalis* (TEMMINCK et SCHLEGEL)), "Umitanago" (a species of minnow) (*Ditrema temminckii* BLEEKER), "Magarei" (Flat fish) (*Limanda Herzensteini* JORDAN et SNYDER), "Hirame" (Flat fish) (*Paralichthys olivaceus* (TEMMINCK et SCHLEGEL)), squid (*Ommastrephes sloani pacificus* STEENSTRUP), "Botan-ebi" (a species of prawn) (*Pandalus hyposinotus* BRANDT). As samples there were taken: in the case of fish, about 5 gm of central back part of the fish meat above lateral line, in the case of squid about 5 gm of back part of the body, in the case of prawn about 5 gm of body meat which was removed from crust. From 5 gm of those various kinds of meat, about 1~2 gm were estimated by the vapour tension method, and about 1 gm each was employed for drying at 40°C.

(2) The vapour tension method

The vapour tension method was the same as that employed in the previously described in Paper I, Experiment III, 1, (1), (III)^{1a}). The temperature at which estimates were made differed with the kind of samples; its range was 15°~21°C.

(3) Cobaltous chloride method

Cobaltous chloride method was that of Oyagi which is the same as that used in the previously described in Paper I, Experiment III, I, (II), (B)^{1a}).

By this method the maximum amount of Bound Water at B.P. during the drying of dyed samples at 25°~30°C was estimated.

(4) Experimental method

For the various samples as above described, the relation between the water-activity " a " of the samples (that is the relative vapour pressure, p/p_0), and various amounts of water-content, " g ", (gm of water per gm of dried matter) was determined by the vapour tension method; also the amount of Bound Water was estimated by the cobaltous chloride method.

On the other hand, slices of the samples about 1 gm in weight were made, and dried in a drier at 35°~40°C. Then they were weighed after taken from the drier at certain definite intervals. From data thus obtained, the relation between the drying time, " t ", and water-content, " g ", was determined.

Here, the drying temperature was decided to be 35°~40°C in order to avoid the heat denaturation (coagulation) of fish protein. The estimation of the amount of Bound Water in fish meat by the cobaltous chloride method is possible at a lower temperature such as 25°~30°C. Therefore, when the drying of fish meat was made at below those temperatures it is feared that the drying of fish meat reaches to equilibrium while still containing an amount of water greater than that regarded as the amount of Bound Water estimated by the cobaltous chloride method. Therefore it was considered that there was need of increasing the thermodynamic energy by keeping the drying temperatures at 35°~40°C.

2. Experimental results and discussion

The results obtained are shown in Tables 17~28 and Figs. 9~20. In every Table, there are shown the relation between the absolute amount of water-content, " g ", obtained by the vapour tension method for each sample and the water-activity of samples " a "; the relation " a " and " $p/g(p_0-p)$ " and the relation between the amount of water-content, " g ", and drying time, " t " (hrs), under constant drying at 40°C. The values of the amount of Bound Water obtained by the cobaltous chloride method are shown in the lower margin of the tables. The relation between " a " and " $p/g(p_0-p)$ " was derived from B.E.T. equation (3) which is offered for the multimolecular layer's adsorption by Brunauer, Emmett and Teller^{23a}) in 1938. The reason for applying B.E.T. equation (3) is that the curve of " $g-a$ " (or " $g-p/p_0$ ") is regarded as a kind of desorption isotherm (that is, isothermal curve for desorption of water) as stated in earlier Paper II^{1b}).

$$p/g(p_0-p) = 1/g_m C + \frac{C-1}{g_m C} \times (p/p_0) \quad (3)$$

where g_m and C are B.E.T. constants.

In Figs. 9~20, each curve I shows the relation for each sample between the absolute amount of water-content " g ", estimated at definite estimating temperature and the water-activity " a " (that is, p/p_0). Each curve II shows the relation between " p/p_0 " and " g/a ". Each straight line III shows the linear relation between " p/p_0 " and $p/g(p_0-p)$ derived by using B.E.T. equation (3). Each curve IV shows the relation between drying time " t " under the drying at 40°C, and the amount of water-content " g ".

Table 17 and Fig. 9 show the experimental results for crucian carp (*Carassius auratus* (LINNE)). As seen by curve IV in Fig. 9, the amount of water-content decreased nearly in a straight line from 0 to 6 hours' drying, then the rate of decrease was small from 6 to 10 hours, and the drying reached nearly to equilibrium at from 11 to 12 hours. In this drying, as the surface area of the dried fish meat has not been estimated, the rate of decrease of water-content for the drying time " t ", " G/t " (where G is the amount of water evaporated per hour) was calculated, and when the relation of " G/t " for every period of drying was observed as drying velocity per hour, the decreasing was seen to be almost exponential function. From this, it is clear that after the initial period of drying, the drying mechanism follows the first stage of falling rate of drying; the difference between the first and second stages of falling rate of drying was

Table 17. Crucian carp meat

Estimation of vapour tension at 15°C			Drying at 40°C	
g^*	p/p_0 (or " a ")	$p/g(p_0-p)$	Drying time " t " (hrs.)	Water-content g^*
1.98	0.932	7.45	0	4.45
0.65	0.891	12.55	1.0	3.28
0.23	0.597	6.45	2.0	2.44
0.17	0.400	3.92	3.0	1.71
0.13	0.300	3.23	4.0	1.16
0.11	0.200	2.18	5.0	0.82
0.10	0.150	1.75	6.0	0.55
0.08	0.100	1.39	7.0	0.36
0.055	0.04	0.76	8.0	0.25
—	—	—	9.0	0.186
—	—	—	10.0	0.156
—	—	—	11.0	0.152
—	—	—	12.0	0.152

* g : Gm of water per gm of dried matter.

$g_{B.P.} = 0.578$ (The amount of Bound Water at the point of B.P. by Oyagi's method).

Table 18. "Soi" meat

Estimation of vapour tension (20.5°C)			Drying (40°C)	
<i>g</i>	p/p_0 (or "a")	$p/g(p_0-p)$	<i>t</i>	<i>g</i>
2.49	0.978	18.7	0	3.98
1.93	0.963	14.1	1.0	2.70
1.48	0.936	10.1	2.0	1.94
1.15	0.889	6.96	2.5	1.68
0.79	0.863	7.97	3.0	1.42
0.53	0.813	8.19	3.5	1.24
0.32	0.675	6.51	4.0	1.04
0.24	0.600	6.25	4.5	0.89
0.21	0.520	5.19	5.0	0.75
0.15	0.450	5.44	6.0	0.54
0.11	0.350	4.99	7.0	0.34
0.09	0.263	3.98	8.0	0.24
0.08	0.200	3.13	9.0	0.21
0.075	0.150	1.58	10.0	0.195
0.070	0.100	1.44	11.0	0.191
0.060	0.064	1.15	12.0	0.191

 $g_{B.P.} = 0.447$

Table 19. Yellow-tail meat

Estimation of vapour tension (20.5°C)			Drying (40°C)	
<i>g</i>	p/p_0 (or "a")	$p/g(p_0-p)$	<i>t</i>	<i>g</i>
3.09	0.992	36.9	0	3.09
1.68	0.972	21.0	1.0	2.24
1.14	0.950	16.7	2.0	1.61
0.86	0.926	14.6	2.5	1.32
0.53	0.870	12.8	3.0	1.08
0.30	0.768	11.1	3.5	0.92
0.173	0.614	14.5	4.0	0.76
0.165	0.500	6.07	4.5	0.63
0.159	0.400	4.19	5.0	0.54
0.152	0.297	2.77	6.0	0.36
0.128	0.250	2.53	7.0	0.24
0.098	0.186	2.32	8.0	0.19
0.089	0.150	2.03	9.0	0.167
0.074	0.100	1.50	10.0	0.161
0.055	0.050	0.963	11.0	0.158
0.042	0.037	0.928	12.0	0.158

 $g_{B.P.} = 0.501$

Table 20. Atka mackerel meat

Estimation of vapour tension (20°C)			Drying (40°C)	
g	p/p_0 (or "a")	$p/g(p_0-p)$	t	g
3.97	0.989	21.2	0	3.99
2.48	0.978	18.1	1.0	2.55
1.77	0.971	18.4	2.0	1.76
1.31	0.946	13.3	3.0	1.18
0.94	0.910	10.6	4.0	0.75
0.69	0.852	8.32	5.0	0.47
0.53	0.797	7.39	6.0	0.29
0.21	0.572	6.28	7.0	0.195
0.14	0.400	4.77	8.0	0.155
0.10	0.263	3.56	9.0	0.153
0.08	0.150	2.20	10.0	0.151
0.07	0.107	1.60	11.0	0.151
0.06	0.050	0.88	—	—

 $g_{B.P.}=0.442$

Table 21. Sardine meat

Estimation of vapour tension (18.5°C)			Drying (40°C)	
g	p/p_0 (or "a")	$p/g(p_0-p)$	t	g
3.30	0.992	40.3	0	3.30
2.33	0.990	42.7	0.5	2.69
1.64	0.985	41.7	1.0	2.23
1.31	0.970	24.9	1.5	1.91
1.10	0.962	23.2	2.0	1.41
0.83	0.950	23.0	2.5	1.19
0.71	0.923	16.9	3.0	0.99
0.59	0.910	18.1	3.5	0.88
0.49	0.857	13.1	4.0	0.76
0.37	0.769	9.22	4.5	0.66
0.28	0.580	4.93	5.0	0.59
0.25	0.499	3.98	6.0	0.44
0.24	0.413	2.94	7.0	0.31
0.22	0.376	2.73	8.0	0.22
0.21	0.280	1.86	9.0	0.16
0.19	0.251	1.77	10.0	0.115
0.18	0.145	0.945	11.0	0.099
0.16	0.084	0.577	12.0	0.095
0.15	0.076	0.549	13.0	0.095
0.145	0.056	0.407	—	—

 $g_{B.P.}=0.608$

Table 22. Mackerel meat

Estimation of vapour tension (21°C)			Drying (40°C)	
g	p/p_0 (or "a")	$p/g(p_0-p)$	t	g
1.55	0.933	9.01	0	2.88
1.16	0.899	7.67	1.0	2.05
0.90	0.875	7.76	2.0	1.43
0.61	0.839	8.58	3.0	1.00
0.41	0.801	9.84	4.0	0.75
0.28	0.693	8.07	5.0	0.55
0.18	0.572	7.39	6.0	0.40
0.13	0.469	6.57	7.0	0.36
0.11	0.384	5.67	8.0	0.255
0.08	0.292	4.37	9.0	0.218
0.075	0.207	3.49	10.0	0.188
0.072	0.150	2.46	11.0	0.178
0.068	0.100	1.63	12.0	0.175
0.065	0.078	1.31	13.0	0.175
0.060	0.050	0.088	—	—

 $g_{B.P.} = 0.557$

Table 23. Tuna meat

Estimation of vapour tension (18.5°C)			Drying (40°C)	
g	p/p_0 (or "a")	$p/g(p_0-p)$	t	g
2.46	0.984	27.8	0	2.54
1.45	0.952	13.4	1.0	1.70
1.03	0.923	11.5	2.0	1.18
0.76	0.893	10.9	3.0	0.85
0.54	0.835	9.38	4.0	0.64
0.33	0.738	8.59	5.0	0.45
0.26	0.650	7.16	6.0	0.32
0.22	0.553	5.04	7.0	0.19
0.17	0.450	4.81	8.0	0.144
0.16	0.344	2.74	8.5	0.125
0.145	0.226	2.01	9.5	0.116
0.140	0.150	1.26	10.5	0.110
0.130	0.098	0.838	11.5	0.107
0.120	0.043	0.375	12.5	0.107

 $g_{B.P.} = 0.631$

Table 24. "Umitanago" meat

Estimation of vapour tension (20.5°C)			Drying (40°C)	
g	p/p_0 (or " a ")	$p/g(p_0-p)$	t	g
2.23	0.965	12.6	0	3.55
1.56	0.955	14.2	1.0	2.06
0.89	0.911	11.6	1.5	1.60
0.54	0.800	7.41	2.0	1.19
0.39	0.714	6.44	2.5	0.89
0.24	0.600	6.25	3.0	0.67
0.18	0.468	4.91	3.5	0.50
0.16	0.400	4.17	4.0	0.36
0.15	0.300	2.85	4.5	0.25
0.13	0.200	1.93	5.0	0.19
0.12	0.150	1.51	6.0	0.155
0.11	0.118	1.22	7.0	0.141
0.08	0.050	0.66	8.0	0.136
0.035	0.035	1.04	9.0	0.136

 $g_{B.P.}$not estimated.

Table 25. "Magarei" meat

Estimation of vapour tension (21°C)			Drying (40°C)	
g	p/p_0 (or " a ")	$p/g(p_0-p)$	t	g
1.89	0.960	12.8	0	4.38
1.22	0.918	9.18	1.0	2.82
0.805	0.871	8.38	2.0	1.64
0.507	0.778	6.88	3.0	0.96
0.315	0.660	6.16	4.0	0.61
0.187	0.536	6.15	5.0	0.36
0.108	0.292	3.82	6.0	0.22
0.093	0.250	3.58	7.0	0.15
0.084	0.200	2.98	7.5	0.144
0.073	0.131	2.05	8.0	0.141
0.059	0.065	1.18	9.0	0.141

 $g_{B.P.}=0.477$

Table 26. "Hirame" meat

Estimation of vapour tension (21°C)			Drying (40°C)	
g	p/p_0 (or " a ")	$p/g(p_0-p)$	t	g
1.75	0.972	20.8	0	3.74
1.05	0.964	24.9	1.0	2.36
0.52	0.876	13.5	2.0	1.50
0.23	0.652	8.09	3.0	0.95
0.17	0.500	5.88	4.0	0.63
0.15	0.400	3.76	5.0	0.37
0.13	0.300	3.29	6.0	0.22
0.12	0.200	2.07	7.0	0.155
0.11	0.168	1.82	8.0	0.144
0.10	0.100	1.11	9.0	0.139
0.07	0.041	0.60	10.0	0.134
—	—	—	11.0	0.134

 $g_{B.P.}=0.541$

Table 27. "Botan-ebi" meat

Estimation of vapour tension (20.5°C)			Drying (40°C)	
g	p/p_0 (or " a ")	$p/g(p_0-p)$	t	g
3.53	0.991	30.9	0	3.53
1.07	0.897	8.17	2.0	2.28
0.75	0.844	6.74	3.0	1.75
0.49	0.749	6.08	4.0	1.26
0.32	0.666	6.23	5.0	0.91
0.22	0.544	5.42	6.0	0.69
0.13	0.388	4.88	7.0	0.50
0.08	0.184	2.81	8.0	0.38
0.07	0.150	2.50	9.0	0.29
0.05	0.100	2.12	10.0	0.226
0.045	0.050	1.17	11.0	0.184
0.040	0.030	0.93	12.0	0.162
—	—	—	13.0	0.162

 $g_{B.P.}=0.574$

Table 28. Squid meat

Estimation of vapour tension (20°C)			Drying (40°C)	
g	p/p_0 (or "a'')	$p/g(p_0-p)$	t	g
2.73	0.988	29.7	0	2.94
1.79	0.974	21.6	1.0	2.22
1.34	0.947	13.3	2.0	1.76
1.07	0.920	10.7	2.5	1.63
0.84	0.904	11.4	3.0	1.48
0.69	0.893	12.2	4.0	1.21
0.59	0.853	9.76	5.0	1.01
0.50	0.842	10.4	6.0	0.76
0.41	0.799	9.61	7.0	0.61
0.35	0.774	9.85	8.0	0.51
0.29	0.742	9.02	9.0	0.39
0.24	0.673	8.44	10.0	0.33
0.21	0.635	8.32	11.0	0.25
0.174	0.573	7.71	12.0	0.21
0.148	0.559	7.78	13.0	0.18
0.124	0.464	6.97	14.0	0.156
0.108	0.443	7.36	15.0	0.137
0.078	0.398	8.48	16.0	0.123
0.064	0.289	6.44	17.0	0.108
0.043	0.186	5.33	18.0	0.100
0.038	0.150	4.23	19.0	0.100
0.032	0.105	3.76	20.0	0.100
0.030	0.050	1.77	—	—

$g_{B.P.} = 0.729$

not clear in the final period of drying. Here, supposing these drying mechanisms of fish meat at 40°C apply to the equation (4) of slow drying²⁷⁾,

$$W = W_1 e^{-\lambda N} \quad (4)$$

where, W_1 : the weight of sample before drying (gm)
 W : the weight of sample after the drying (gm)
 N : drying time "t", (hours)
 λ : drying coefficient (gm/hrs)

The values of drying coefficient for crucian carp meat calculated from equation (4) are shown in the 12th~14th columns of Table 29. The value of λ_1 was 0.244 in the range of 0~8 hrs. of drying time, the value of λ_2 was 0.025 in the range of 8~10 hrs. The proportion of λ_2 to λ_1 ($\lambda_2/\lambda_1 \times 100\%$) was 10.2%.

For various other kinds of samples, the proportions of λ_2 to λ_1 (%), ranged 10~18% as shown in Table 29.

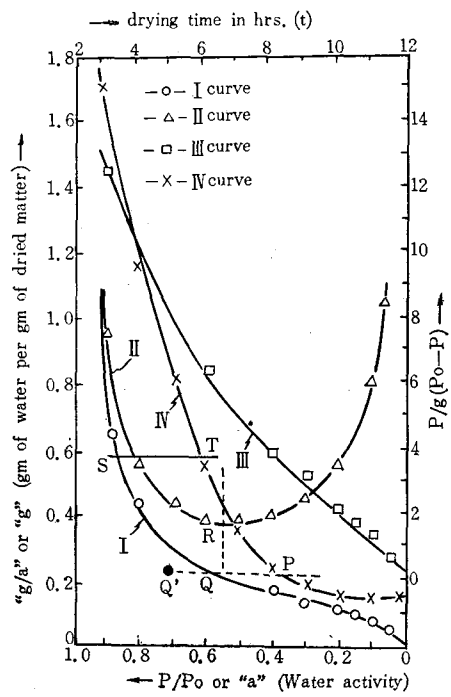

Fig. 9. Crucian carp meat

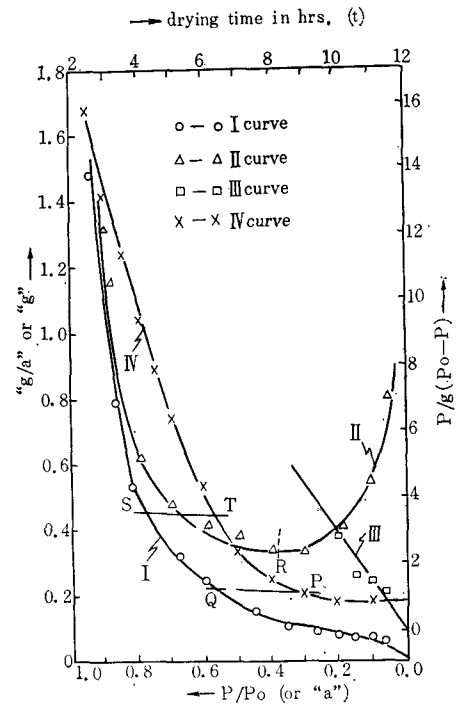

Fig. 10. "Soi" meat

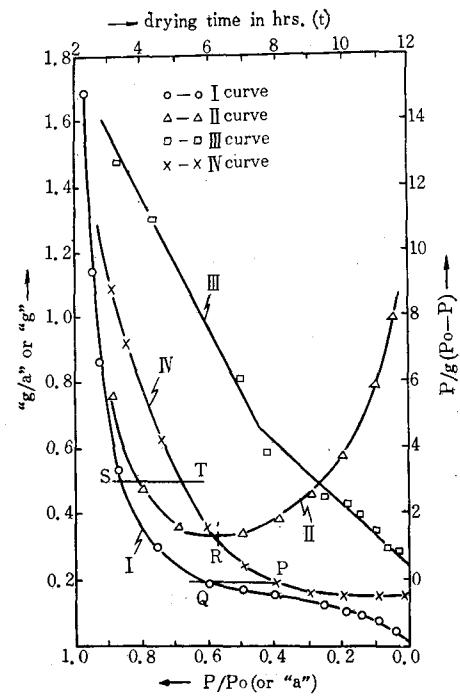

Fig. 11. Yellow-tail meat

I curve ($g-p/p_0$), II curve ($p/p_0-g/a$), III curve ($p/p_0-p/g(p_0-p)$), IV curve ($g-t$)
 (Similar signs in subsequent figures show the same mean as in these figures.)

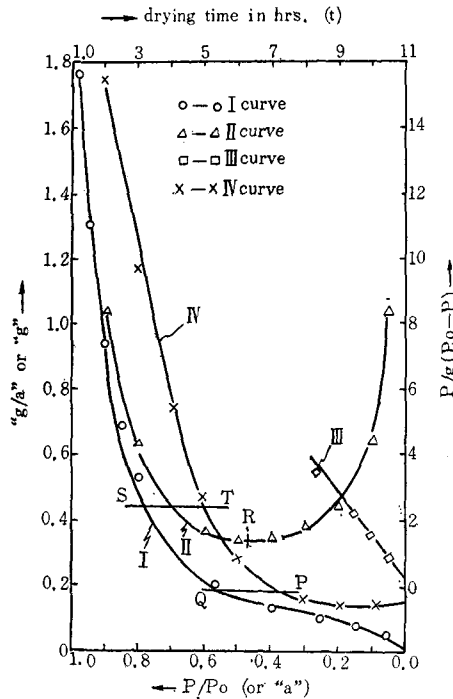

Fig. 12. Atka mackerel meat

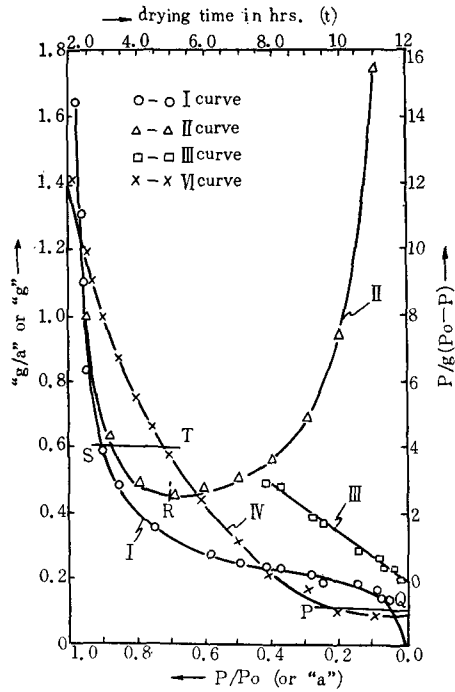

Fig. 13. Sardine meat

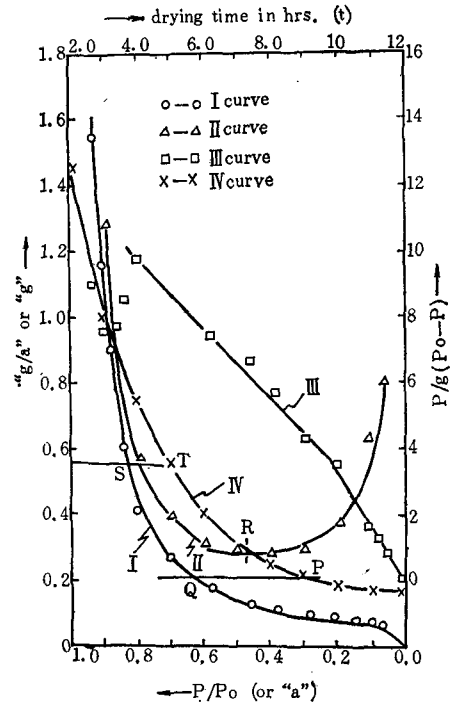

Fig. 14. Mackerel meat

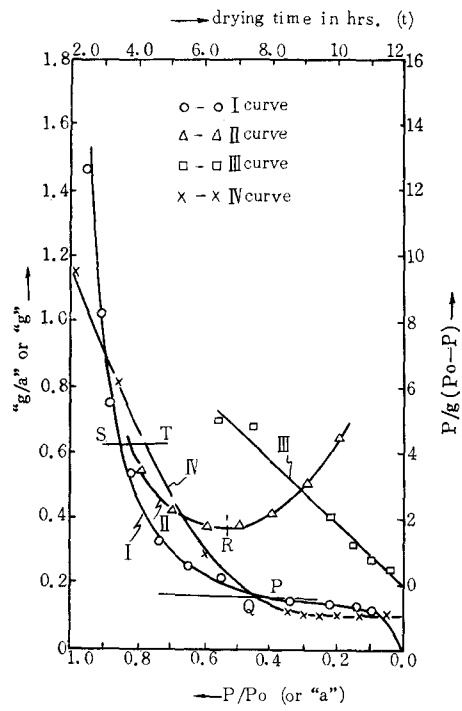

Fig. 15. Tuna meat

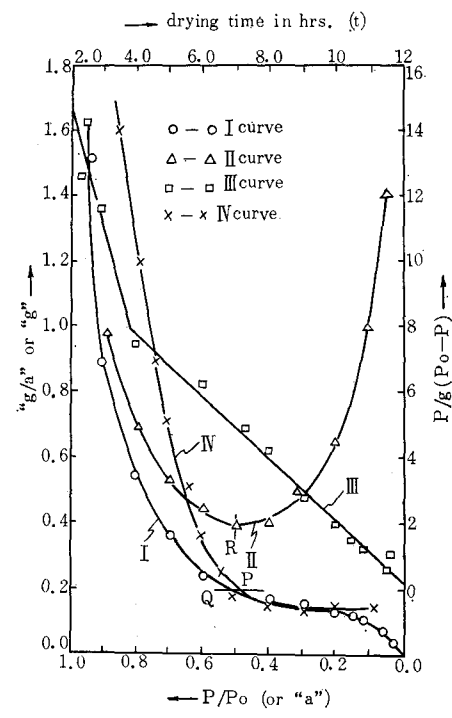

Fig. 16. "Umitanago" meat

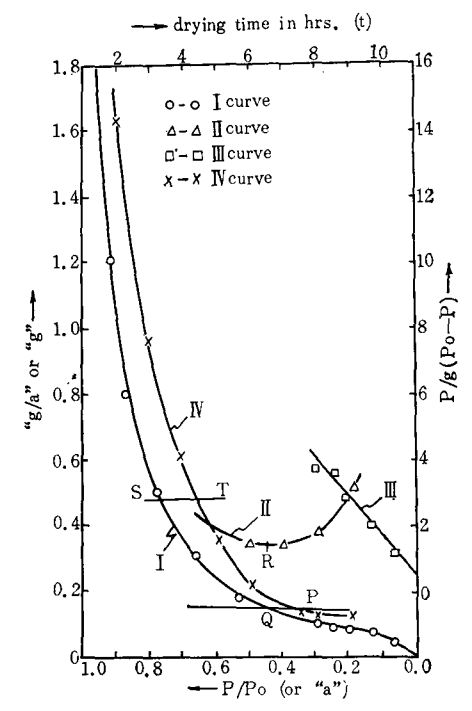

Fig. 17. "Magarei" meat

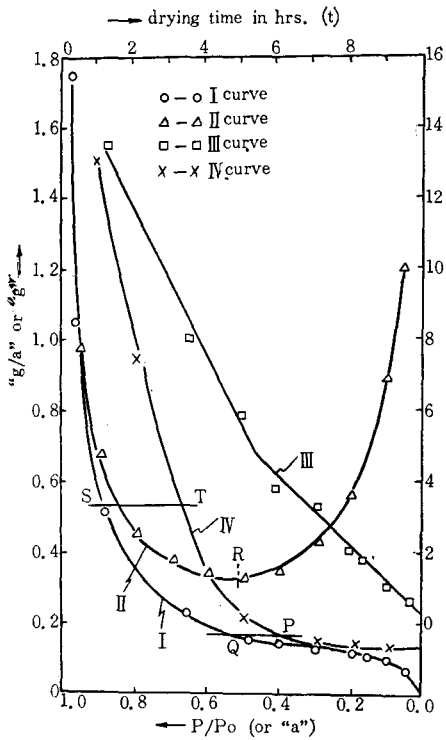

Fig. 18. "Hirame" meat

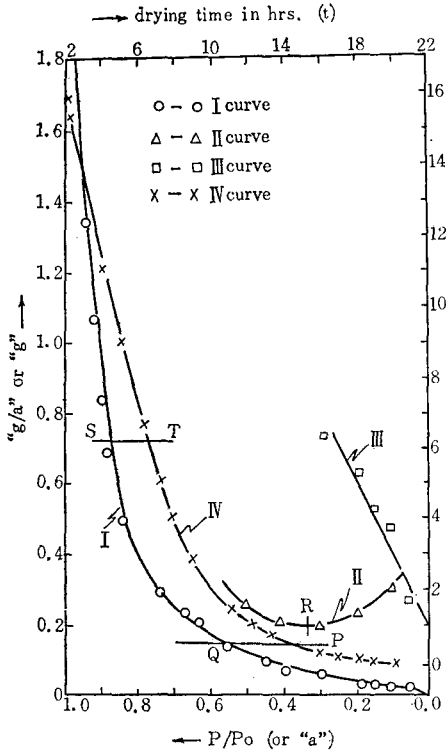

Fig. 19. Squid meat

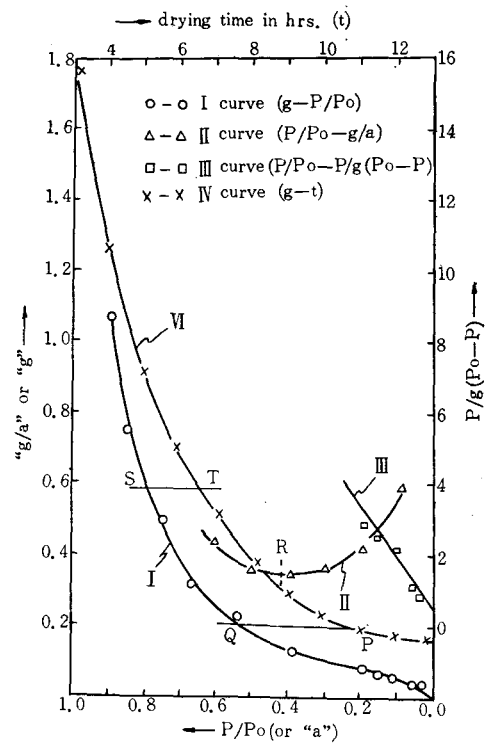

Fig. 20. "Botan-ebi" meat

Table 29. The influence of Bound Water upon the velocity of drying of fish meat

Sample	Est. temp. (t°C)	B.E.T. constant		g'm	"a" at g'm	g'm/gm	E ₁ -E _L Kcal/mol	g _P	"a" at (g _P)t _{exp.} °C	"a" at (g _P)t=40°C	Drying coefficient, λ		
		C	g _m								λ ₁	λ ₂ at g _P	λ ₂ /λ ₁ × 100 %
Crucian carp	15	25	0.108	0.208	0.545	1.93	1.8	0.218	0.575	0.739	0.224 (0~8 hrs.)	0.025 (8~10 hrs.)	10.2
"Soi"	20.5	15.5	0.0645	0.130	0.390	2.02	1.6	0.210	0.530	0.629	0.183 (0~7 hrs.)	0.0195 (7~9 hrs.)	10.7
Yellow-tail	20.5	14	0.107	0.185	0.580	1.73	1.5	0.190	0.600	0.704	0.171 (0~7 hrs.)	0.029 (7~9 hrs.)	16.8
Atka mackerel	20.0	53	0.0755	0.160	0.470	2.12	2.3	0.195	0.550	0.707	0.223 (0~6 hrs.)	0.032 (7~9 hrs.)	14.4
Sardine	18.5	108 ?	0.142	0.31	0.680	2.18	2.6	0.11	0.04	0.055	0.157 (0~8 hrs.)	0.023 (9~11 hrs.)	14.6
Mackerel	21	271 ?	0.0613	0.120	0.420	1.96	3.3	0.215	0.634	0.658	0.141 (0~8 hrs.)	0.025 (8~10 hrs.)	17.7
Tuna	18.5	15	0.098	0.180	0.560	1.84	1.6	0.170	0.40	0.484	0.142 (0~8 hrs.)	0.024 (7~9.5 hrs.)	16.8
"Umitanago"	20.5	10	0.095	0.198	0.500	2.08	1.3	0.190	0.500	0.575	0.267 (0~5 hrs.)	0.0276 (5~6 hrs.)	10.3
"Magarei"	21	15	0.078	0.148	0.450	1.90	1.6	0.150	0.460	0.531	0.253 (0~6 hrs.)	0.031 (0~6 hrs.)	12.2
"Hirame"	21	44	0.0100	0.165	0.500	1.65	2.9	0.170	0.500	0.536	0.226 (0~6 hrs.)	0.0298 (6~8 hrs.)	12.8
Squid	20	22	0.046	0.08	0.350	1.72	1.8	0.140	0.520	0.633	0.098 (0~12 hrs.)	0.016 (12~18 hrs.)	16.3
"Botan-ebi"	20.5	38	0.073	0.138	0.400	1.89	2.1	0.190	0.515	0.544	0.139 (0~9 hrs.)	0.025 (10~12 hrs.)	18.0

The values of drying coefficient, λ_1 , decreased remarkably (10~18%) at the turning point of "p" on the "t-g" curve (curve IV) in Fig. 9 showing the drying curve for crucian carp meat (and other samples) and then reached to the state of drying equilibrium.

The author has considered the turning point on the curve IV, "P", the boundary between the first stage and the second stage of falling rate of drying.

The value of the amount of water-content at the turning point, g_P , (the gm of water per gm of dried matter) is 0.218 for crucian carp meat as shown in the 9th column of Table 29. The values for other samples were 0.14~0.215, except for the value of sardine at 0.11.

In order to transfer the turning point, "P", of curve IV onto the curve I ($g-a$ curve), a parallel line was drawn from the point of "P" with the abscissa in Fig. 9 (or in other Figs.), then this parallel line crossed with curve I. The intersection is the point of "Q".

The value of "a" at the point of "Q" for crucian carp was 0.575 as shown in the 10th column of Table 29. The values of "a" for other samples were 0.4~0.65 excepting the value for sardine at 0.04. From those Figs., the values of drying coefficient of the final period of drying at 40°C decreased to 10~18% of those coefficient of the initial period as a boundary with the amount of water-content " g_P " at 0.4~0.65 of the values of "a".

In Fig. 9 and other Figs., curves I and IV were divided by the T-S line. The intersections ("T" and "S") indicate $g_{B.P.}$ showing the amount of Bound Water estimated by the cobaltous chloride method. The point of "T" or "S" shows the point at which pink coloured samples dyed with cobaltous chloride solution become blue. The value of "a" at the point of "S" on curve I in Fig. 9 was about 0.87 for crucian carp meat. The values of "a" for other samples were in the range of 0.75~0.95. That is to say, points of "S" in Figs. were situated in the range of 0.75~0.95 of "a". From those results it is considered that the amount of Bound Water estimated by the cobaltous chloride method " $g_{B.P.}$ " seems to be larger than the water-content at respective points "Q" or "P" on curves I or IV, and the value of "a" for the values of " $g_{B.P.}$ " seems to be larger than the value of "a" for the value of " g_P " estimated at the point of "Q".

In curve of " $p/p_0-g/a$ " (curve II) as seen in Fig. 9 and other Figs., the value of " g/a " decreased with the decreasing of value of " p/p_0 ", that is to say, it decreased with the decreasing of the amount of water-content in the initial period of drying, and the value of " g/a " showed the minimum value at the point, "R", on curve II.

However, on the contrary, the value of " g/a " increased below the value of "a" corresponding to the point of "R".

The value of the amount of water-content "g" which shows the value of "a" corresponding to the point of "R" was determined from curve I, and expressed as " g'_m " as shown in the 5th column of Table 29. This value of " g'_m " for crucian carp was 0.208, those for other samples were about 0.12~0.20 excepting the values of " g'_m " for sardine, 0.31, and for squid, 0.08.

Those values of " g'_m " are somewhat smaller than the value of " g_P " corresponding to the point of "P" which is the turning point of curve IV or corresponding

to the point of "Q" on curve I, but the values of the former are comparatively similar to that of the latter. The value of "a" corresponding to the value of " g'_m " for squid was the minimum, 0.350, and that for sardine was maximum, 0.680, as shown in column 6 of Table 29. The values for other samples were naturally in the range between the minimum and maximum values above stated.

As seen in curve III of Fig. 9 and other Figs., the relation between the values of " p/p_0 " and " $p/g(p_0-p)$ " is found clearly to be linear. But in Fig. 9 showing the crucian carp meat, the straight line curve III is divided into two parts, and the inclinations of those two parts (two straight lines) are different in the ranges of the value of "a", 0~0.5 and 0.6~0.9.

This change in inclination means the appearance of a new activated surface on the adsorption layer at the adsorption of water molecule. In the case of crucian carp meat, the value of constant, " g_m ", in equation (3) calculated from the relation of the straight line showing the value of " p/p_0 " to be in the range of 0~0.5 in the initial process of adsorption, was 0.108 (per gm of dried matter) as listed in column 4 of Table 29. The value of " g_m " in this case means the amount of water required to cover the surface of fish meat protein with one molecule of water layer.

For the various other samples, the flat fish ("Magarei") was 0.078 (minimum value), and the sardine was 0.142 (maximum). That is to say the values of " g_m " distributed in the range of 0.07~0.15.

As previously stated, the value of " g'_m " an amount of water-content corresponding to the value of "a" at the point of "R" on curve II, was found to be 0.208 for crucian carp meat. The values of the ratio of g'_m to g_m , " g'_m/g_m ", are shown in 7th column of Table 29. The value for crucian carp meat was 1.93. For the various other kinds of samples, the values of the ratio were 2.18 for sardine (maximum), 1.65 for "Hirame" meat (minimum), and 1.92 on the average.

According to the results obtained for various poly-molecular compounds by Bull²²⁾, the value of " g'_m/g_m " (as the value of v'_m/v_m was expressed in his study) was 2 on the average. He has pointed out that the adsorption process of the first layer is complete at " g_m " of the water-content, and the adsorption of the second layer continues to the water-content of " g'_m ", while at above the value of " g'_m ", the most part of water keeps liquid state, and it comes to have the properties of a true solution.

In conclusion, it may be said that the amount of water-content, " g_P " at the turning point of "P" on the drying curve at 40°C (curve IV) are somewhat larger than the value of " g'_m " of the water-content showing the value of "a" corresponding to the point of "R" on curve II, but the two values are almost similar. The values of "a" at " g_P " of the water-content were about 0.40~0.64. However, strictly speaking, as the process of water evaporation from the sample continues with thermodynamic energy corresponding to 40°C of the drying temperature, the value of " g_P " at the turning point "P", on drying curve IV must be transferred onto the " $g-p/p_0$ " curve which may be obtained at 40°C.

Generally the " $g-p/p_0$ " curve slips down to the value of 1.0 (to the left side), with the rising of estimating temperature, in other words, the value of "a" at a

certain water-content slips down to the value of 0 (to the right side) with falling of the temperature. The values of curve I in Figs. 9~20 were estimated within the temperature range of 15°~21°C, therefore, point "Q" on curve I ought to decline to the left side in the case of the estimation at 40°C. As it was impossible to estimate at above 25°C owing to the less capacity of manometer of the vapour tension apparatus, the estimation of vapour pressure at 40°C has not been done.

In order to know the slipping degree of the point "Q", the values of "C", a constant concerned with the heat of adsorption in B.E.T. equation (3), were calculated from the linear relationship of the values of p/p_0 to $p/g(p_0-p)$, and these values obtained are shown in column 3 of Table 29 for every kind of samples.

According to B.E.T. theory, this constant value "C" is expressed as follows,

$$C = a_1 g / b_1 \exp (E_1 - E_L) / RT \quad (5)$$

where, " a_1 " and " b_1 " are constants concerned with water-condensation and evaporation properties on the first layer of adsorption surface: " g " is the ratio of both constants at above second layer, b_i/a_i , in which " i " is the number of adsorption layers, that is,

$$i = 2, 3, 4, \dots n \dots$$

Supposing that, for the simplify

$$g = b_i / a_i$$

$$\text{then, } a_1 = a_i \text{ and } b_1 = b_i$$

therefore, equation (5) becomes

$$C = \exp (E_1 - E_L) / RT \quad (6)$$

From equation (6), $E_1 - E_L$, an adsorption heat of water in the sample under consideration, can be calculated, where E_1 is the adsorption heat of the first layer, and E_L is the heat of liquefaction of pure water, that is 9.7 Kcal/mol. As shown in column 8 of Table 29, the values of $(E_1 - E_L)$ for each sample are in the range of 1.3~3.3 Kcal/mol.

As reported in a previous Paper II^{1b)}, the author has determined the curve of " $g-a$ " at 13° and 8°C for gelatine and studied the relation between the change of the differential molal enthalpy, $\Delta\bar{H}$, at the adsorption and the values of " a "; according to the results obtained, the value of $\Delta\bar{H}$ was above 10 Kcal/mol in the range of 0.2~0.0 of " a ", 3~7 Kcal/mol in the range of 0.2~0.7 of " a " and with the progressing of adsorption, the value of $\Delta\bar{H}$ decreased rapidly to 0~2 Kcal/mol at above 0.7 of " a ". In that case the value of $(E_1 - E_L)$ was obtained as 3.8~3.9 Kcal/mol for gelatine. The value of $(E_1 - E_L)$ of fish meat obtained in this experiment is less than that of gelatine, so the value of $\Delta\bar{H}$ of fish meat is also supposed to be somewhat less than that of gelatine. In the range of 0.4~0.65 of " a " at point "Q" corresponding to point " g_P " in Fig. 9 and other Figs., the value of $\Delta\bar{H}$ is considered to be less than 3~4 Kcal/mol, so the values of $(E_1 - E_L)$ for each sample in Table 29 may be regarded as the values of $\Delta\bar{H}$ without much difference between them. Therefore, in the following equation (7) of Clausius Clapeyron, if the values of " a ", corresponding to point "Q" on curve I of each sample at various estimating temperature T_1 , are known, and supposing the value of $\Delta\bar{H}$ equals with the value of $(E_1 - E_L)$; then the values of a_2 corresponding

to 40°C of estimating temperature ($T_2=273.1+40=313.1^\circ\text{K}$) can be calculated.

$$\Delta\bar{H} = -\frac{RT_1T_2}{T_1-T_2} = \ln a_2/a_1 \quad (7)$$

The results of calculation thus obtained are shown in the 11th column of Table 29.

The value of "a" corresponding to point "Q" in Fig. 9 which was 0.575 for crucian carp meat was recognized to change to 0.739 of the value of "a" corresponding to point Q' at 40°C estimating temperature. Similarly, the value of "a" for other samples was 0.484 for tuna meat (minimum) while the maximum value was 0.739 for crucian carp, as above stated, except the value of sardine at 0.055. These values correspond to the point of "Q". That is to say, the point of Q' seems to distribute in the range between the 0.48~0.74 value of "a". However, as a general characteristic of the "g-a" curve, with the rising of temperature, the value of "g_m" in the equation of B.E.T. (3) and the value of "g'_m" of water-content showing the value of "a", corresponding to point "R" on curve III, became less. (But in general, the values of "a" corresponding to point "R" are comparatively independent from the change of temperature.) Therefore, the water-content, "g_P" estimated at point "P" on the drying curve of 40°C (Curve IV) seems to be somewhat larger than those of "g'_m" (and "g_m") on the "g-a" curve estimated at 40°C. From results as above obtained, the turning point "P" on the drying curve of 40°C is to be regarded as the changing point from the first stage of falling rate of drying to the second stage. The value of "a" of the water activity of sample showing the water-content, "g_P", is below about 0.7. According to Bull's result²²⁾ and the present author's results obtained for gelatine, fish meat protein and raw fish meat previously described in Paper II^{1b)}, water of which the value of "a" is below 0.7, is to be regarded as the so called molecular theoretical Bound Water which mainly consists of hydrogen binding. Therefore, in such a range of values of "a" below 0.7, the rate of drying remarkably decreased and the second stage of falling rate of drying seems to be in progress.

The amount of Bound Water obtained by the cobaltous chloride method (Oyagi's method) (that is the value of the amount of water-content at points S, T, on curves I and IV) is far larger than that of water-content at "g_P" or "g'_m" in each Fig. Further, as the value of "a" corresponding to the amount of Bound Water, "g_{B.P.}", is in the range of 0.75~0.95 as above stated, this Bound Water should be regarded as colloidal Bound Water rather than as molecular theoretical Bound Water. In this experiment, as to the above consideration, there seemed to be no particular difference among the kinds of fish meat.

3. Conclusion

In the case of drying of fish meat at 40°C, the absolute amount of water-content (gm of water per gm of dried matter) "g", decreased in the initial period of drying with the drying time "t" almost in the linear relation. For example, when the value of "g_P" was 0.218 for crucian carp meat, and the values of "g_P" were 0.14~0.22 for other fish meat, the drying coefficient "λ₂" decreased rapidly to 10~18% of the initial drying coefficient "λ₁". The value of "a" in each sample

Table 30. The influence of Bound Water upon the velocity of drying of fish meat

Sample meat	Raw fish meat			Water-content at point of "B.P."	Water-content at point of "P"	$\frac{g_P}{g_{B.P.}} \times 100$ (%)	Water-content being in a state of equilibrium in the drying at 40°C (%)
	R.T.* (%)	R.B.* (%)	R.F.* (%)	A($g_{B.P.}$) (% in original)	B(g_P) (% in original)		
Crucian carp	81.6	10.6	71.0	36.6	17.9	48.9	13.2
"Soi"	79.9	9.0	70.9	30.9	17.4	56.3	16.0
Yellow-tail	75.6	12.2	63.4	33.3	16.0	48.1	13.7
Atka-mackerel	80.0	8.8	71.2	30.6	16.3	53.3	13.1
Sardine	76.8	14.1	62.7	37.7	9.9	26.3	8.7
Mackerel	74.3	14.3	60.0	35.8	17.7	49.5	14.9
Tuna	71.8	17.8	53.0	38.7	14.5	37.5	9.7
"Umitanago"	78.0	—	—	—	16.0	—	12.0
"Hirame"	78.9	11.4	67.5	35.0	13.0	37.2	11.8
"Magarei"	81.4	8.9	72.5	32.3	14.5	44.9	12.3
Squid	74.6	18.5	56.1	42.1	12.3	29.2	9.1
"Botan-ebi"	78.0	12.6	65.4	36.4	16.0	44.0	13.9

* R.T.=Total Water content in raw material (%).
 R.B.=Bound Water content in raw material (%).
 R.F.=Free Water content in raw material (%).

corresponding to each amount of water-content, " g_p " as above stated, were 0.40~0.65 for various kinds of fish meat.

As the values of the constant " g_m " in B.E.T. equation (3), (an amount of water required to cover the surface of a molecule of fish meat protein with a monomolecular water layer), 0.07~0.15 were obtained. This is almost one half of the amount of water-content at " g_F ".

According to Bull²²⁾ and the present author^{1b)}, water having the amount of water-content of twice the value of " g_m ", or water having below 0.7 of the water-activity " a " is considered to be molecular theoretical Bound Water. Therefore, in the case of drying of fish meat at 40°C, the velocity of drying of the meat decreased by the existence of molecular theoretical Bound Water. In the 2nd, 3rd and 4th columns of Table 30, the total amount of water-content of fresh raw fish meat (R.T. %), the amount of Bound Water (R.B. %), and that of Free Water (R.F. %) are shown respectively. In column 5, the percentage of the amount of water-content regarded as only Bound Water (A%) is shown. In column 6 the amount of water-content at the turning point " P " of the drying curve at 40°C (B%) is shown.

As seen in Table 30, the total water-content of fresh raw fish meat for crucian carp was 81.6%. In this total amount of water-content, there are included 10.6% of Bound Water and 71.0% of Free Water. When this fish meat was dried, the total water-content decreased to 36.6% (A); the water in this dried fish meat is to be regarded as colloidal Bound Water. With the progress of drying, when the total amount of water-content reduced to 17.9% (B), the velocity of drying at 40°C decreased rapidly, and the water in sample at that time went into the sphere of molecular theoretical Bound Water.

The ratio of B to A ($B/A \times 100$) was 48.9% for crucian carp meat as shown in column 7 of Table 30, and about 37~57% for other kinds of fish excepting 26.3% for sardine and 29.2% for squid. That is to say, the velocity of drying decreased rapidly in the range of 37~57% to the amount of Bound Water estimated by cobaltous chloride method. However, in the drying at 40°C, the amount of water-content being in a state of equilibrium was 13.2% for crucian carp, and 9~16% for other kinds of fish meat. In sun-drying of fish meat, the limit total amount of water-content of drying is considered generally to be 18~25%. In such values the velocity of drying may be remarkably influenced by the presence of colloidal Bound Water, and drying time is considered to become longer.

IV. ON THE RELATION BETWEEN THE "DRIP" FORMATION AND THE AMOUNT OF BOUND WATER DURING THE REFRIGERATION OF FISH MEAT

"Drip" is the liquid separated from the frozen fish or meat after being thawed. There are two kinds of "Drip". One of them is "Free drip" which is separatable naturally or by light pressure. The other is "Expressible drip" which separated from the frozen fish or meat by heavy pressure, *e.g.* 1~2 atmospheres,

gauge pressure). Those "Drips" contain a large amount of various nutritive chemical components and tasty or flavourous matters. The larger the amount of those separated liquids becomes, therefore, the lower becomes the commercial value of the frozen goods.

Many studies on the formation of "Drip" have been made up to the present³⁰⁾. According to results obtained, the principal cause of the formation is the chemical and physical changes, *e.g.* the denaturation of meat protein and the destruction of muscle tissue by the formation of ice crystals when the material is refrigerated. In the present experiment, the author has studied the relation between the formation of "Drip" and the denaturation of fish meat protein during storage (at -18°C) of the fish meat quick-frozen at -30°C , in order, as nearly as possible, to prevent the destruction of muscle tissue by keeping them at very low temperature. Then he studied the change of properties of Buond Water owing to the denaturation of fish meat protein by formation of ice crystals, (that means the dehydration or the condensation of electrolytes in fish meat), during the refrigeration and storage, by means of comparing the relation between the water-content and the relative vapour pressure (water-activity).

Next, a study was made of the change of the hydrating affinity of the "Drip" only, and of fish meat after separation of "Drip" respectively.

To prevent the formation of "Drip", Tarr³¹⁾ has studied the soaking of fish meat in NaCl solution before refrigeration.

The present author has studied the hydration of fish meat protein by various kinds of salt in order to learn the way to prevent the formation of "Drip".

1. Experimental part

(1) *On the relation between the freshness of the fish meat and the amount of "Drip" formed*

(i) Sample

As sample, fillet meat of Atka mackerel (*Pleurogrammus azonus* JORDAN *et* METZ) was employed.

(ii) Estimation of the amount of "Drip"

The estimation of the amount of "Drip" was carried out continuously for the "Free drip" and then "Expressible drip".

(A) Estimation of "Free drip"

About 200 gm of fillet meat sliced from the frozen fish was hung in the room (room temperature, $16^{\circ}\sim 19^{\circ}\text{C}$; relative humidity, about 75%) and thawed. The liquid which separated from the fillet meat during the thawing was received into a vessel.

The proportion (%) of the decreasing weight to the initial weight of the fillet meat used was expressed as the amount of "Free drip". The time when the dripping was finished over is the limit time for the estimation of "Free drip". It required about 16 hours to complete the estimation. During that time, the evaporation of moisture from the surface of the fillet meat was out of consideration. The samples were employed in as nearly the same shape and same size as possible.

(B) Estimation of "Expressible drip"

The sample from which "Free drip" was separated out sufficiently was put into a canvas bag, and this bag was placed in a rectangular gunmetal box (the size of the mouth was 7×7 cm) as shown in Fig 21.

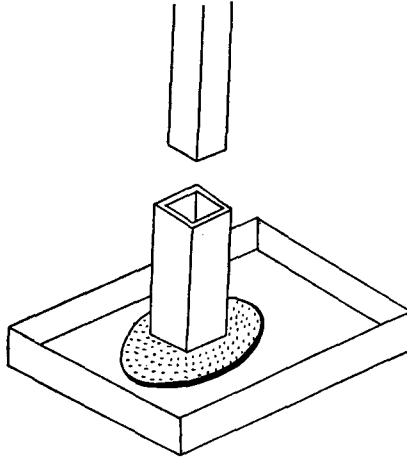

Fig. 21. Estimating apparatus of the amount of "Drip" in frozen fish muscle

Then the bag was pressed by a pressing machine. The pressure was estimated by a pressure gauge. The liquid separated from the sample was received in a vessel. The canvas bag was weakly pressed during the initial period; then after 10 minutes strongly pressed at 0.5 kg/cm^2 of power. The pressure was continued in the same strength during 20~30 minutes. The liquid thus separated is obtained as "Expressible drip". The amount of "Expressible drip" is expressed by the proportion (%) of the amount of the liquid separated to the initial weight of the fillet meat taken before the "Free drip" estimation was carried out.

(iii) Experimental method

Five raw Atka mackerel, of which the freshness was very good, in the period of rigor mortis were brought to the laboratory. One of them was employed as a raw sample (Sample E) without refrigeration. This sample was immediately used for the estimation of the amount of "Drip". The other sample was immediately frozen in an Iwamoto's contact-plate freezing apparatus at -30°C for 14 hours (Sample A) and stored at -18°C for 25 days. This sample was used for the estimation of the amount of "Drip".

Each of the three other Atka mackerel were left alone in a room (room temperature, $20^\circ\text{C} \pm 3^\circ\text{C}$) and then were frozen an intervals of 4 hours leaving in the same apparatus. This leaving in a room was done in order to decrease the freshness in various stages. Those samples were called B, C, and D, respectively from the different leaving times.

Sampl D left alone for 12 hours was unfresh; the meat became soft but edible. The amount of volatile basic nitrogen estimated for Sample E (fresh

raw without refrigeration) was 2.5 mg%; for Sample D it was 20 mg%. The freshness of this Sample D seemed to be in a stage before incipient putrefaction.

(iv) Experimental results and discussion

The results obtained were shown in Table 31 and Fig. 22.

From Table 31 and Fig. 22, the total amount of "Drip", including both categories, "Free" and "Expressible", is seen to increase with the falling of the freshness of samples used.

As seen in the proportion of "Free drip" or "Expressible drip" to the "Total drip", the values of "Free drip" increased, and those of "Expressible drip" decreased with the falling of freshness of samples.

According to the results obtained in the previous Section II, with the decomposition of fish meat protein, the proportion of the amount of Bound Water to Total water-content decreased, and that of Free Water relatively increased; further, the electrical resistance decreased (That is, there was an increasing of electric conductivity). The author has inferred from the results above stated

Table 31. Difference of the amount of "Drip" from the frozen fish meat of different stages of freshness (Atka mackerel meat frozen at -30°C and stored at -18°C for 25 days)

Sample	Free drip (F.D.)		Exp. drip (E.D.)		Total drip* (T.D.) (%)
	F.D. (%)	$\frac{\text{F.D.}}{\text{T.D.}} \times 100$ (%)	E.D. (%)	$\frac{\text{E.D.}}{\text{T.D.}} \times 100$ (%)	
A	7.6	39.5	11.6	60.5	19.2
B	9.8	45.0	12.0	55.0	21.8
C	11.1	47.6	12.2	52.4	23.3
D	15.0	51.0	14.4	49.0	29.4
E**	0	0	2.0	100	2.0

* T.D.=F.D.+E.D.

** Unfrozen meat

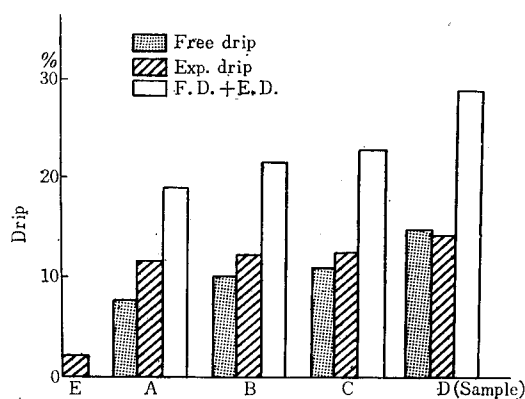

Fig. 22. Relation between the amount of "Drip" and the freshness of fish meat (Atka mackerel)

that the binding affinity of water in fish meat decreases with the decomposition of fish meat protein.

It is easy to infer, therefore, that the amount of "Free drip" estimated may increase when unfresh meat is frozen.

It is important to use the raw fish meat as fresh as possible in order to minimize the amount of formation of "Drip". In the control-sample (Sample E) which was raw without refrigeration, the leakage of "Free drip" could not found, and the amount of "Expressible drip" was estimated at only about 2% by weight as shown in Table 31.

On the contrary, in Sample A frozen under very fresh state, the amount of "Free drip" was 7.6%, "Expressible drip" was 11.16%.

According to the experimental results of the Korean Fisheries Experimental Station³²⁾, the amount of "Drip" of fresh frozen fish meat differs with the kind of fish, and thawing temperature; the amount of "Expressible drip" was obtained to be 5~45% in the range of 5°~45°C of experimental temperature.

From those results, it may be generalized that the formation of "Drip" is unpreventable in the frozen fish meat, and the formed amount of "Drip" increases with longer time of freezing storage. Therefore, it is clear that the formation of "Drip" is remarkably influenced by the properties of fish meat, freezing conditions and storage conditions after refrigeration. In the further experiments, the fish meat having similar freshness was employed in order to equalize the internal factors before the refrigeration.

(2) *The relation between the amount of "Drip" formed and the storage period of frozen fish meat*

In this experiment, ten Atka mackerel were quickly frozen at -30°C by Iwamoto's quick freezing apparatus, and stored at -17°C~-18°C for 2 months. At certain definite intervals each one fish was taken and the amounts of "Free drip" and "Expressible drip" were estimated by the method previously described.

The results obtained are shown in Table 32 and Fig. 23.

As seen in Fig. 23 the amount of "Free drip" increased clearly with the longer time of storage. On the contrary, the amount of "Expressible drip" was

Table 32. Change of the amount of "Drip" during the storage of frozen Atka mackerel meat (Freezing temperature -30°C, freezing time 14 hrs, storage temp. -17°~-18°C)

Drip	Days								
	2	5	8	10	16	23	26	38	57
Free drip (%)	5.6	4.5	7.0	9.4	10.6	12.2	10.9	15.1	17.6
$\frac{\text{F.D.}}{\text{E.D.} + \text{F.D.}} \times 100$	(31.8)	(17.4)	—	(41.5)	(46)	(46)	(46.4)	(57.5)	(55)
Exp. drip (%)	12.0	21.0	—	16.9	12.5	14.4	12.6	12.2	14.4
$\frac{\text{E.D.}}{\text{E.D.} + \text{F.D.}} \times 100$	(68.2)	(86.2)	—	(58.5)	(54)	(54)	(53.6)	(42.5)	(45)
E.D.+F.D. (%)	17.6	25.5	—	22.6	23.1	26.6	23.5	27.3	32

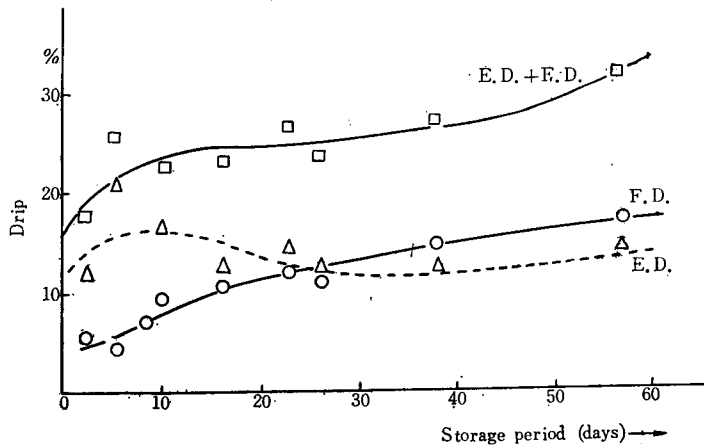

Fig. 23. Change of the amount of "Drip" during the storage of frozen Atka mackerel meat

larger than that of "Free drip" in the initial period of storage after the freezing, but the former amount decreased with the longer time of storage, and after 25 days' storage the amount became little.

The sum of "Expressible drip" and "Free drip" (the total amount of "Drip") increased clearly with the longer time of storage just as amount of "Free drip" did; this agrees with the results of Moran³³). As seen in Table 32, the ratio of "Free drip" to the "Total drip" increased with the longer time of storage; and, contrariwise, the ratio of "Expressible drip" decreased. This seems to be because a part of "Expressible drip" which has been estimated in the initial period of the storage changed to "Free drip" with the passage of the storage time. It has generally been said that from fish meat which was slowly frozen a larger amount of "Free drip" separates than that of "Expressible drip"; on the contrary, from quickly frozen fish meat the amount of "Expressible drip" has been said to exceed that of "Free drip". However, according to the present author's results which were obtained from fish meat quickly frozen at -30°C , the amount of "Expressible drip" was more than that of "Free drip" only in the initial period of storage, thereafter, the amount of "Free drip" becomes more than that of "Expressible drip".

When as a cause of the formation of "Drip", histological change of fish meat tissue at the freezing is considered, the size of ice crystals formed in slowly frozen fish meat is large; the destruction of muscle tissue, therefore, is considered to be great and the amount of "Free drip" is much. On the other hand, the size of ice crystals formed in quickly frozen fish meat is small, therefore the destruction of muscle tissue is considered to be slight, and the amount of "Expressible drip" is little. However, even in the quickly frozen meat where the destruction of tissue is considered to be slight, the amount of "Free drip" increased with the longer time of storage, even at a low temperature such as -18°C . Hence the formation of "Drip" in this experiment is considered to be mainly due to the

dehydrating denaturation of fish meat protein rather than to the histological damage.

(3) *The comparison of the curve of the water-content and the water-activity of sample, "g-a" in the fresh raw meat and frozen meat*

Fresh raw meat of Atka mackerel and the same meat which was frozen quickly at -27°C and stored at -18°C for two weeks were employed for the vapour pressure measurement at 15°C , then the relation between the water-content, "g" (gm of water per gm of dried matter) and the relative vapour

Table 33. Relation between the water-content "g" and the water-activity "a" in fresh raw and frozen Atka mackerel meat

Fresh raw meat		Frozen meat	
Water-content "g"	Water-activity "a" or " p/p_0 "	"g"	"a" or " p/p_0 "
0.774	0.91	1.16	0.91
0.568	0.87	0.38	0.79
0.344	0.83	0.16	0.47
0.223	0.63	0.13	0.26
0.213	0.48	0.11	0.19
0.210	0.41	0.09	0.10
0.150	0.14	—	—
0.110	0.06	—	—

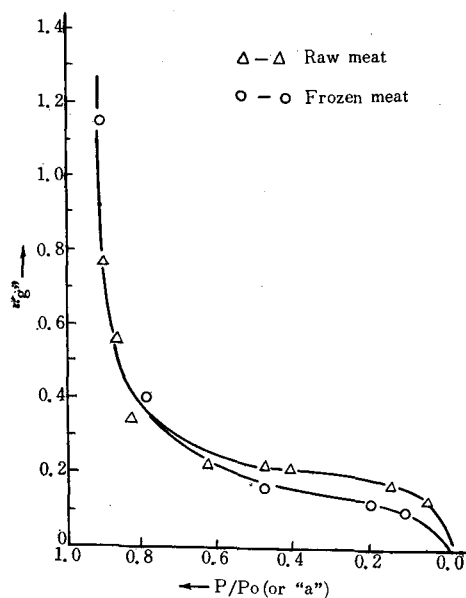

Fig. 24. "g-a" curves for the fresh raw and frozen Atka mackerel meat

pressure, p/p_0 , (or water-activity "a") was observed.

The estimation of vapour pressure was carried out with the same apparatus as described in the previous Paper I^{1a}). The equivalent pressure between the vapour pressure of pure water and that of water in the sample was estimated. The results obtained are shown in Table 33 and Fig. 24.

As seen clearly in Fig. 24, the relation between "a" and "g" is expressed by almost the same curve in the fresh raw fish meat and frozen meat until the value of "a" is 1.0~0.6 and the value of "g" is 0.2, but when the value of "g" is below 0.2, the value of "a" of the frozen meat is higher than that of fresh raw meat in comparison with the same water content, "g". That is to say, the curve "g-a" of the former slips down to the left side of that of the latter. This fact shows clearly that the differential molal free energy of water in the frozen fish meat decreases to a less degree than that of water in the fresh raw fish meat.

Here, when the differential molal free energy of pure water is F° , and that of water in the sample at the same temperature is \bar{F} , the difference of the two is shown as following equation (8) as stated in previous Paper II^{1b}).

$$\Delta\bar{F} = F^\circ - \bar{F} = -RT \ln p/p_0 \quad (8)$$

In equation (8), when the values of $\Delta\bar{F}$ were calculated and compared for each amount of water-content, "g", results were obtained as set forth in Table 34 and Fig. 25.

As seen clearly in Fig. 25 the value of $\Delta\bar{F}$ of water in the frozen fish meat is less than that in the fresh raw fish meat when the water-content "g" is below 0.3.

That is to say, the differential molal free energy of water in frozen fish meat is shown to come up to that of pure water, in other words, water in frozen fish meat became free state. In Fig. 24, water of which the value of "a" is below 0.7 is considered to be molecular theoretical Bound Water, therefore in this case, it is considered that the formation of "Drip" from the frozen meat is due to the loss of hydration of fish meat protein rather than due to a physical factor such as the destruction of tissue by means of freezing of fish muscle.

Table 34. The comparison of the differential molal free energy of water in fresh raw and in frozen Atka mackerel meat

Water-content "g"	Fresh raw meat		Frozen meat	
	"a" or " p/p_0 "	$\Delta\bar{F}$ (cal/mol)	"a" or " p/p_0 "	$\Delta\bar{F}$ (cal/mol)
1.0	0.92	47.8	0.92	47.8
0.7	0.90	60.5	0.90	60.5
0.4	0.82	114	0.82	114
0.3	0.73	180	0.73	180
0.2	0.40	525	0.54	353
0.15	0.14	1,100	0.36	586
0.10	0.05	1,720	0.13	1,170

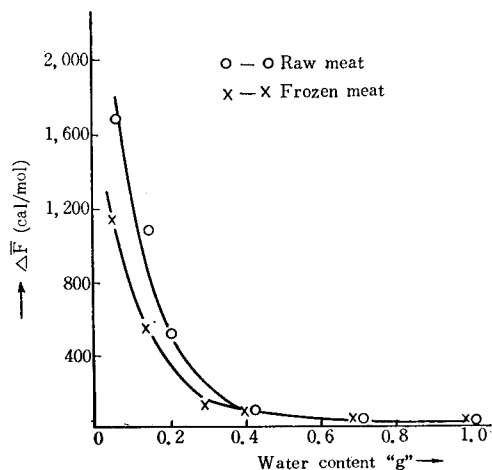

Fig. 25. " $g-\Delta\bar{F}$ " curve for the fresh raw and frozen Atka mackerel meat

(4) *The comparison of curves "g-a" of the frozen fish meat, fish meat dripped out and "Drip" liquid respectively*

Comparisons were made of the curves " $g-a$ " of Atka mackerel meat which was quickly frozen at -30°C and stored at -18°C for two weeks, of the meat from which "Free drip" had been lost and of the meat from which "Expressible drip" had been removed. The results obtained are shown in Table 35 and Fig. 26.

In Fig. 26, curve I is the curve " $g-a$ " of frozen fish meat, curve II shows that for the fish meat less "Free drip", curve III shows that freed of "Expressible drip", curves IV and V show those for "Free drip" only and "Expressible drip" only, respectively. As seen clearly in those curves, the values of the water-activity " a " in curves II and III became smaller than that in Curve I from the point of about 0.65 of the value of the water-activity " a " (that is 0.3 of the water-content " g "), when those curves were compared at the same amount of water-content. That is to say, curves II and III slipped above curve I at below 0.65 of the value of the water-activity, " a ".

This fact shows that the differences in the differential molal free energy of pure water and that of water in "Drip"-freed fish meat were greater than those of frozen fish meat. Water in fish meat from which "Drip" had been separated seems to have comparatively stronger affinity with the fish meat protein.

When the water-activity " a " is above 0.65, curves I, II and III were in piles and became one curve just as seen in Fig. 26.

There is some difference between curves II and III, but curve III seemed to slip down to the right side. Therefore, water in fish meat from which "Expressible drip" was separated has stronger affinity with the fish meat protein than was found in fish meat from which "Free drip" was separated.

From the fact that the values of " a " on curve V slipped down to the right side on curve IV, the "Expressible drip" (as curve V) seems to show properties of water having large differential molal free energy in comparison with "Free

Table 35. The relation of curves "g-a" among the frozen Atka mackerel meat, the meat from which "Drip" had been separated and "Drip" liquid only

Sample	Water-content "g"	Water-activity "a" or "p/p ₀ "
Frozen meat (I)	0.77	0.83
	0.27	0.63
	0.22	0.38
	0.19	0.37
	0.18	0.24
Meat dripped out Free drip (II)	0.98	0.85
	0.34	0.72
	0.25	0.49
	0.25	0.46
	0.24	0.33
Meat dripped out Exp. drip (III)	0.65	0.81
	0.26	0.54
	0.24	0.42
	0.22	0.16
Free drip (IV)	6.17	0.87
	0.64	0.62
	0.20	0.52
	0.13	0.32
Exp. drip (V)	3.76	0.76
	0.47	0.67
	0.28	0.10
	0.22	0.05

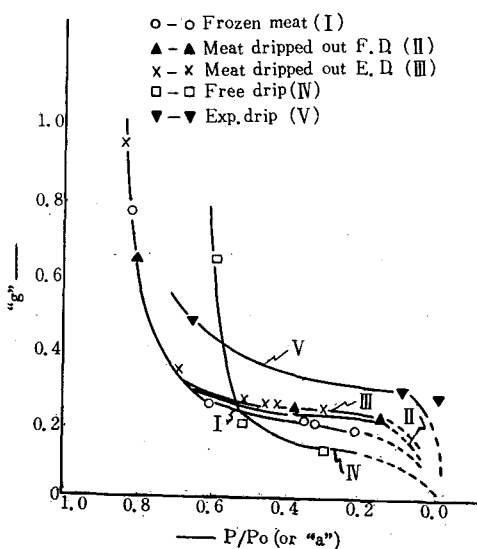

Fig. 26. "g-a" curves for frozen Atka mackerel meat, the meat from which "Drip" had been separated and "Drip" liquid only

drip", but it is impossible to affirm positively the result as above stated, because there is some impurity (meat pieces *etc.*) in both types of "drip".

From article (1)~(4), a principal cause of the formation of "Drip" in quickly frozen fish meat during storage may be stated to be the decrease of affinity of Bound Water with fish meat protein owing to the denaturation of fish meat protein, because the value of differential molal free energy of water regarded as molecular theoretical Bound Water of which the value of water-activity "*a*" is below 0.7 on the curve "*g-a*", decreased during freezing storage.

(5) *Examination of soaking of fish meat in various kinds of salt solution as a method for preventing the formation of "Drip"*

As previously stated, Tarr³¹⁾ has devised a method of soaking fish meat in NaCl solution for a very short time before freezing in order to prevent the formation of "Drip".

The present author has examined this soaking method. In previous Experiments (1)~(4), a cause of the formation of "Drip" during freezing storage was considered to be that water in fish meat is set free by the dehydrating denaturation of fish meat protein, and then the value of $\Delta\bar{F}$ of water in the fish meat decreases. From the fact as above obtained, if the method of increasing the value of $\Delta\bar{F}$ has been found for raw fish meat, it would seem possible to prevent to a certain degree the formation of "Drip" during freezing storage. The soaking of fish meat into salt solution works to decrease the vapour pressure of water in the surface of fish meat, that is to say, it means the increase of $\Delta\bar{F}$. The effect of the soaking method which devised by Tarr³¹⁾ is due to the increase of $\Delta\bar{F}$. According to Tarr, when an adequate concentration of NaCl solution having high swelling activity for fish meat was employed, the amount of "Drip" became much less. Taking those results into consideration, the soaking of fish meat in solution having an adequate values of pH seems to have the same preventing effect for "Drip" formation as the soaking in salt solution. As a matter of fact, Taylor³⁴⁾ has studied a method of preventing the formation of "Drip" by soaking in solution having certain definite values of pH. According to his results the amount of "Drip" decreased with the increasing of the value of pH. The present author has studied the influence of hydrogen ion concentration and kinds of salt of the soaking solution upon the swelling of fish meat.

(i) *The influence of hydrogen ion concentration of soaking solution upon the swelling of fish meat*

As samples, Atka mackerel meats cut in pieces of about $3 \times 3 \times 2$ cm size (15~20 gm in weight) were used. Each piece was put into 10 times volume of buffer solution having various values of pH, and left alone in the room for 24 hours. After soaking, the weight of each sample was estimated. The degree of the swelling "*S*" was expressed by the proportion of the weight of soaked sample, "*W*", to that of sample before soaking, "*W*₀", (W/W_0 , %).

The result is shown in Table 36 and Fig. 27.

As seen clearly in Fig. 27, the degree of swelling of fish meat is the smallest at pH 6~7, and it increased at pH values of above or below 7. Generally, it is said that ampholyte such as protein containing diamino acid and dicarboxylic acid indicates the maximum degree of the swelling at pH 2~3 and pH 10~12³⁵⁾.

Table 36. The degree of swelling of Atka mackerel meat soaked in buffer solutions having various pH values

pH	2.25	4.05	6.12	7.01	8.02	9.34	10.84
S	1.19	1.13	1.13	1.11	1.17	1.16	1.24

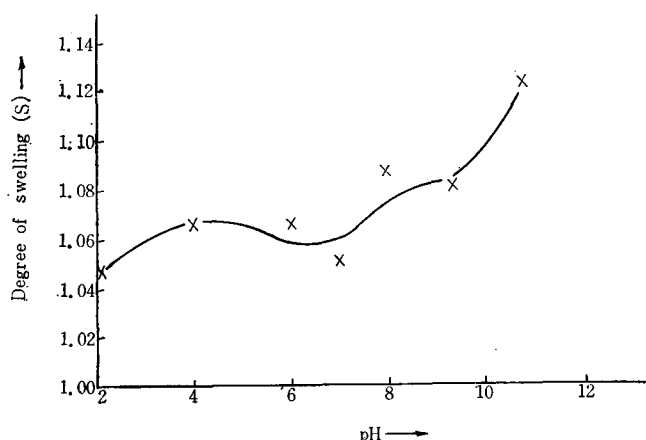

Fig. 27. Relation between the value of pH and the degree of swelling of Atka mackerel meat

Curve "g-a" was obtained for samples which were soaked in solution having 4.05, 7.01 and 10.84 pH values as shown in Table 37 and Fig. 28.

In Fig. 28, curve I shows the relation between "g" and "a" for fresh raw fish meat without soaking (as control sample), curve II shows that for fish meat soaked in pH 4.05 solution, curve III shows that in pH 7.01 solution, and curve IV shows that in pH 10.84 solution.

As seen in Fig. 28, the values of "a" in curves II, III and IV were smaller than "a" in curve I at the same amount of water-content, and those curves slipped down to right side from curve I. That is, by soaking of fish meat in

Table 37. Relation of "g" and "a" of Atka mackerel meat soaked in solutions having various pH values

Fresh raw meat		Soaked meat in pH 4.05 soln.		Soaked meat in pH 7.01 soln.		Soaked meat in pH 10.84 soln.	
"g"	"a"	"g"	"a"	"g"	"a"	"g"	"a"
0.77	0.91	1.40	0.93	1.80	0.87	1.24	0.89
0.57	0.87	0.41	0.82	0.54	0.80	0.35	0.81
0.34	0.83	0.27	0.56	0.23	0.61	0.23	0.53
0.22	0.63	0.19	0.06	0.17	0.10	0.16	0.23
0.21	0.41	0.15	0.04	0.15	0.06	0.13	0.13

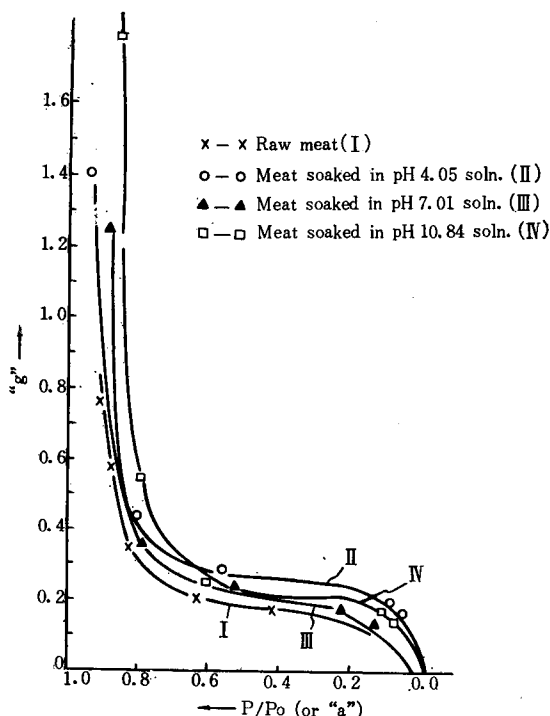

Fig. 28. "g-a" curves for Atka mackerel meat soaked in solutions having various pH values

buffer solution the degree of swelling increased and the value of $\Delta\bar{F}$ of water in the fish meat increased.

When those soaked fish meat samples are frozen, with the decrease of the value of $\Delta\bar{F}$ of water in fish meat during the storage, the formation of "Drip" may be somewhat lessened as suggested in above article. In practical case of soaking of fish meat in buffer solution, it is feared that the soaking is rather effective in the surface part of fish meat, but it may not be so effective in the inner part of fish meat, because the soaking solution does not penetrate perfectly into the inner part of fish meat in which the water has the same property as that of fresh raw fish meat even after the soaking. However, even if water in the inner part of fish meat should be set free during the freezing storage, as there is a water layer having large value of $\Delta\bar{F}$ and having hydration in the surface part of the fish meat, the amount of "Drip" which may be separated when thawed would seem to be slight.

(ii) The relation between the concentration of NaCl solution and the value of pH which exerted influence upon the degree of swelling of fish meat

Table 38 and Fig. 29 show the degree of swelling of Atka mackerel meat during the soaking of it in the NaCl solution having various molar concentration for 24 and 48 hours. In the last column of Table 38, the values of pH after soaking are tabulated.

Table 38. Relation between the concentration of NaCl solution and degree of swelling of Atka mackerel meat

Conc. of NaCl (Mol)	Degree of swelling, "S"		pH (after soaking)
	24 hrs. after	48 hrs. after	
0 (Dist. water)	1.00	—	—
0.05	1.23	1.19	6.16
0.1	1.20	1.18	6.22
0.2	1.17	1.19	6.14
0.5	1.21	1.24	6.12
1	1.18	1.24	5.93
2	1.09	1.15	5.85
3	1.10	1.20	5.75
4	0.98	1.06	5.73
5	0.94	0.96	5.65
6	0.92	0.96	5.64

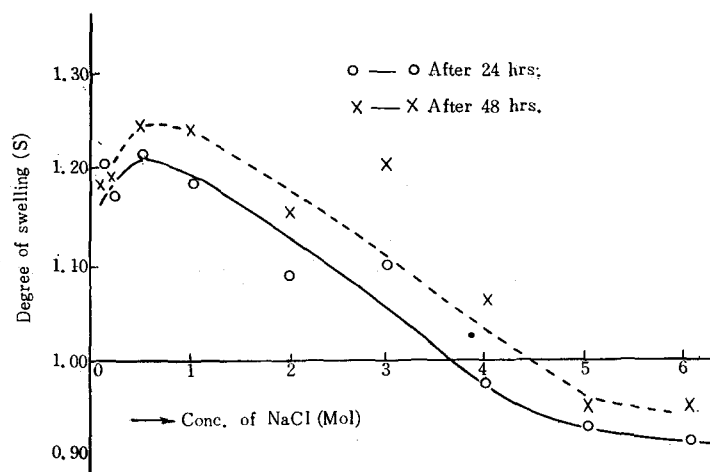

Fig. 29. "Conc.—S" curve for Atka mackerel meat in NaCl solution

As seen in Fig. 29, after 24 hours' soaking, the degree of swelling of fish meat showed the maximum value in about 0.5 Mol (2.9%) of NaCl solution. Below 0.5 Mol or above 1 Mol (5.8%) the degree of swelling decreased, and above 3.5 Mol (20.5%) the value of the degree of swelling fell below 1. After 48 hours' soaking, the values of degree of swelling are generally larger than that those of 24 hours' soaking. The maximum value of degree of swelling was shown in 0.8 Mol (4.68%) of NaCl solution, and above 4.5 Mol (26.3%) its value of swelling dropped below 1.

According to Tarr's statement³¹⁾, the relation between the degree of swelling of halibut meat (5 × 5 × 2.5 cm in size) and soaking time was attained to equilibrium after 5~6 days in 2% NaCl solution.

In his result, the maximum value of degree of swelling was shown in 5~7% (0.85~1.2 Mol) of NaCl solution.

The present author's result almost agreed with Tarr's result.

As seen in Table 38, the values of pH of various concentrations of NaCl solution after soaking of fish meat varied to the acidic side with the increase of the concentration of NaCl solution.

As to the swelling of fish meat in salt solution, there is perhaps some relation between the concentration of salts and the value of pH of that salt solution.

The present author has estimated the degree of swelling of Atka mackerel meat after soaking in 0.86 Mol (5%) NaCl solution of which the values of pH varied 2~11. The value of pH of the NaCl solution was adjusted by addition of 1 N H₂SO₄ or 1 N NaOH solution. The results obtained are shown in Table 39 and Fig. 30.

Table 39. The degree of swelling of Atka mackerel meat after soaking in 0.86 Mol (5%) NaCl solution of which the value of pH varied 2~11

pH	2.35	4.35	6.14	6.96	8.15	9.13	10.85
S	1.32	1.30	1.37	1.34	1.26	1.33	1.26

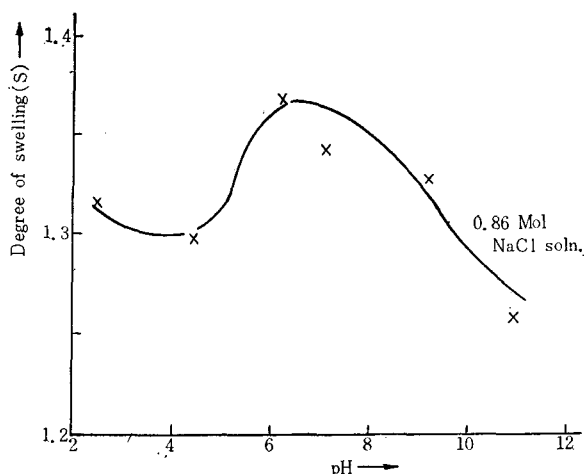

Fig. 30. "pH-S" curve for Atka mackerel meat in 0.86 Mol (5%) NaCl solution

As seen in Fig. 30, the degree of swelling of fish meat "S", is the minimum at about pH 4, it increased rapidly at pH 4~6, it is the maximum at about pH 6~7, and it decreased above pH 7~11. Below pH 4 the value of "S" increased somewhat.

Comparing Fig. 30 with Fig. 27, the swelling in acidic side is restrained below pH 5 by the adding of salts, and contrariwise is promoted above pH 5. Those results agreed with Tarr's findings.

The experiment shown in Fig. 27 was carried on by using of buffer solution,

that in Fig. 30 was carried on by adding of H_2SO_4 or NaOH solution. Comparing the values of "S" in both experiments, the value of "S" in Fig. 30 is seen to be larger than "S" in Fig. 27.

In Tarr's studies, both experiments were carried on by using of the same buffer solution. According to Tarr, in the range of pH 2~4 of the acidic side the value of "S" which was added with salt was larger than "S" without adding of salt, and in the range of pH 5~7, the result was contrary.

From the result as above obtained in case of solution to which was added no salt, following conclusions can be drawn.

The maximum swelling was showed at pH 2 or pH 10, and the concentration of NaCl solution for the maximum swelling was 0.5~1.0 Mol (2.93~5.8%). In the case of adding of salts, the pH value of maximum swelling changed to pH 6~7 from pH 10. In acidic side, the degree of swelling decreased more than in the case of no adding of salt.

From those findings, the soaking of fish meat in solutions of pH 2 or 10 is considered to be effective to prevent the formation of "Drip", but this soaking is not practical. Particularly in the acidic side, the denaturation of fish meat protein occurs remarkably during the freezing storage³⁶), therefore the soaking of fish meat in solution of pH 2 shows least effect.

To prevent the formation of "Drip", the soaking of fish meat in NaCl solution of which the concentration is 0.85 Mol (5%) NaCl solution with pH value of 6~7 seems to be the best for practical use.

Concerning practical experiment, according to Tarr's result, when the halibut meat was soaked in the solution (pH 7.10, 5% NaCl) containing 2.5 gm of NaCl and 50 cc of 0.2 N NaOH, and the soaked fish meat left alone at 1°~5°C for 24 hours, the amount of "Expressible drip" was 12%. In the case of soaking in 5% NaCl solution, the amount of it was 18.8%; on the other hand, in the case of the use of dil. HCl solution or water only, the amount of it was 63~52%. The present author's result above obtained agreed with Tarr's result. That is to say, it is the best to use for the soaking solution 5% (0.85 Mol) NaCl solution with pH 6~7 value.

(iii) The influence of various kinds of salt upon the degree of swelling of fish meat

Following salts and chlorides were used as substances for addition:

Na-salts —NaCl, Na_2SO_4 , $NaNO_3$, $Na_2B_4O_7 \cdot 10aq.$, $Na_3PO_4 \cdot 12aq.$

CH_3COONa , $C_3H_4(OH)(COONa)_3 \cdot 3aq.$

K-salts —KI, KCl, KNO_3 , K_2SO_4 , K_2CO_3 , CH_3COOK

Chlorides—KCl, $CaCl_2$, $MgCl_2 \cdot 6aq.$, NH_4Cl , NaCl

A 0.6 Mol soaking solution was prepared with those salts and chlorides, and Atka mackerel meat was soaked in each solution for 24 hours. The values of degree of swelling were estimated as above described. The results obtained are shown in Table 40 and Fig. 31.

From Fig. 31, when cation is the same and anion is different, following facts were observed;

In Na-salts: the degree of swelling "S" decreased in the following order:

Table 40. The degree of swelling of Atka mackerel meat by the various salts (0.6 Mol soln.)

Salts	"S"	Salts	"S"
NaCl	1.25	K ₂ SO ₄	0.91
Na ₂ SO ₄	0.98	K ₂ CO ₃	1.29
Na ₂ B ₄ O ₇ ·10aq.	1.06	CH ₃ COOK	1.06
Na ₃ PO ₄ ·12aq.	0.98	KCl	1.37
CH ₃ COONa	1.43	CaCl ₂	1.15
NaNO ₃	1.33	MgCl ₂ ·6aq.	1.20
C ₃ H ₄ (OH)(COONa) ₃ ·3aq.	0.85	NH ₄ Cl	1.24
KI	1.39		
KNO ₃	1.35		

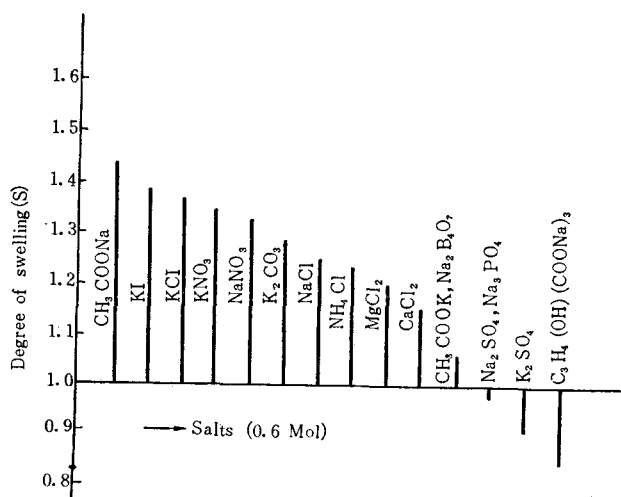
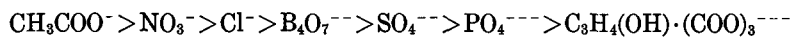
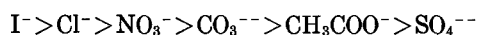

Fig. 31. The degree of swelling of Atka mackerel meat by the various salts (0.6 Mol soln.)



The values of "S" of Na₂SO₄, Na₃PO₄ and C₃H₄(OH)(COONa)₃ were less than 1.

In K-salts, the degree of swelling "S" decreased in the following order:



The value of "S" of K₂SO₄ is less than 1.

When anion is the same and cation is different, the values of "S" decreased in the following order:

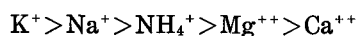

The order of decreasing of the values of "S" of various salts and chlorides is as follows:

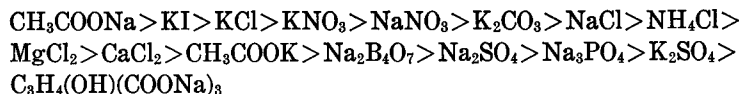

The order of decreasing of the values of "S" is different with ionic strength. Those results obtained by the present author were in the case of the use of 0.6 Mol solution.

Samejima³⁷⁾ has studied the swelling effect upon silk fibroin by K-salts and obtained following results;

In solution of 0.6 Mol: The order of swelling effect is:

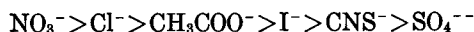

In the solution of 1 Mol: The order of swelling effect is:



In the solution of nitrate, the order of swelling effect by cation is as follows:

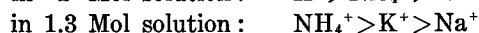
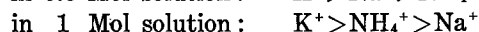
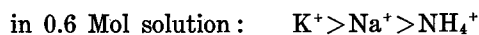

Generally, fish meat protein is dehydrated and coagulated by electrolytes in the high concentration (above 3 Mol). Contrarily, in the low concentration (0.05~0.2 Mol), electrochemical adsorption of ions occurs, while in medium concentration (0.2~1 Mol) both adsorption by electric charge and surface-chemical adsorption occur, respectively, according to concentration of soaking solution.

According to Migita's observation³⁸⁾ for the setting phenomenon, "Suwari" of fish paste, in medium concentration of electrolytes, ionic hydration by surface chemical adsorption seems to be effective.

The accuracy of the series of swelling effect of various ions in this experiment must be examined in detail in future.

But as far as indicated by the present author's findings, ionic action in the swelling effect of 0.6 Mol solution of various salts seems to be situated between the surface-chemical adsorption and electrochemical adsorption.

From results as above obtained, in the solution of 0.6 Mol, the swelling effects of KCl, KNO₃ and NaNO₃ are larger than that of NaCl. Therefore using of those salts seems to be suitable for preventing the formation of "Drip".

The using of KNO₃ or KCl for the soaking solution seems to be rather suitable than the using of NaCl, because of the penetration of those K-salts into red meat (including fish meat) more rapidly³⁹⁾ and it keeps the bright red colour⁴⁰⁾.

2. Conclusion

The relation between the cause of the formation of "Drip" which is separated from frozen fish meat when thawed and Bound Water was studied by vapour tension method using Atka mackerel meat. According to the results obtained, a principal cause of the formation of "Drip" is the dehydrating denaturation of fish meat protein. At this time, a part of water regarded as molecular theoretical Bound Water is set free and the value of $\Delta\bar{F}$ of water in frozen fish meat decreased below that of fresh raw meat.

The method of soaking fish meat in NaCl solution, or in solution of which the value of pH is adequate to prevent the formation of "Drip", was examined. The soaking method is employed for the purpose of the increase of the value of $\Delta\bar{F}$ of water in fish meat.

From the results obtained, the following conclusions are formulated.

(1) The amount of "Drip" in frozen fish meat increases with falling in freshness of raw material.

(2) The longer the storing time is, the larger the amount of "Drip" becomes.

(3) Water in fish meat from which "Drip" had separated has large value of $\Delta\bar{F}$, that is to say, the water has strong affinity with fish meat protein.

(4) In the case of soaking of fish meat in NaCl solution, the maximum degree of swelling is shown in the concentration of 3.5% (0.6 Mol).

(5) With regard to the influence of hydrogen ion concentration, in the case of no adding of salts, the minimum value of degree of swelling is shown at pH 4~7, the value of degree of swelling increased at above pH 7 or below pH 4. In the case of adding of salt, the maximum value of degree of swelling is shown in 0.86 Mol NaCl solution having pH 6~7 values.

(6) When the effects of swelling in 0.6 Mol (3.5%) solution of various kinds of salts and chlorides are compared, following series were obtained.

In Na-salts; $\text{CH}_3\text{COO}^- > \text{NO}_3^- > \text{Cl}^- > \text{B}_4\text{O}_7^{--} > \text{SO}_4^{--} > \text{PO}_4^{---} > \text{C}_3\text{H}_4(\text{OH})(\text{COO})_3^{---}$

In K-salts; $\text{I}^- > \text{Cl}^- > \text{NO}_3^- > \text{CO}_3^{--} > \text{CH}_3\text{COO}^- > \text{SO}_4^{--}$

In chlorides: $\text{K}^+ > \text{Na}^+ > \text{NH}_4^+ > \text{Mg}^{++} > \text{Ca}^{++}$

The larger the value of the degree of swelling is, the more effective the preventing of the formation of "Drip" is. From this results, the using of K-salts seems to be suitable for preventing the formation of "Drip" than using of Na-salts.

V. VARIATION OF THE AMOUNT OF BOUND WATER DURING SALTING OF FISH MEAT

The author has examined the relation between the total amount of water and the amount of Bound Water in the meat of Atka mackerel (*Pleurogrammus azonus* JORDAN *et* METZ), mackerel (*Scomba japonicus* HOUTTUYN) and squid (*Ommastrephes sloani pacificus* STEENSTRUP) during the dry salting or brine salting by means of the cobaltous chloride method described in the previous Section II.

According to the results obtained, at the time of the decrease of the percentage of the total amount of water in the fish meat by the phenomenon of osmotic dehydration during salting, the amount of Free Water decreased at first, while that of Bound Water increased relatively.

The absolute amount of Bound Water (per gm of dried matter) in Atka mackerel meat decreased with the longer time of salting storage, but those in mackerel and squid meat increased temporarily at the initial period of the salting.

However, the decrease of the absolute amount of Bound Water in Atka mackerel meat is not peculiar to the kind of fish, because the chemical components are different with the kind of fish and there is some variation of the absolute amount of solid matter in the samples of fish meat.

In previous experiment, the penetration of NaCl has not been estimated. In the present experiment, both the estimation of the amount of Bound Water by the cobaltous chloride method, and the quantitative analysis of NaCl which had penetrated into fish meat were made, moreover the variation of the amount of Bound Water in fish meat during salting were reexamined.

In addition, the reabsorption phenomenon of water by "Protein-salts complex", which has been recognized by many investigators^{40a)41)} was also examined.

1. Experimental part

(1) Experiment I (Preliminary experiment)

(i) Sample

In this experiment, Atka mackerel meat was employed as sample. At sampling, Atka mackerel was cut in both fillets and those fillets were cut a quarter from the lateral line. From back parts of these quarter fillet, some pieces of fish meat ($1.5 \times 1.5 \times 1.5$ cm in size) were taken.

(ii) Method of experiment

In this experiment, brine salting with NaCl was employed. The concentration of brine used was 7.2%, 13.7% and 25.4%. Each of 10 pieces of the sample was put into 100 cc. brine each of the various concentrations as above mentioned.

After soaking of those pieces of fish meat, two pieces each were taken out at certain definite intervals. Estimations of the amount of NaCl penetrated into the sample and the amount of water-content were made. The amount of NaCl was estimated by Rusznyak's method⁴²⁾.

The amount of water was estimated by drying method as usual (drying temperature was $100^{\circ}\sim 105^{\circ}\text{C}$).

(iii) Results of experiment and discussion

The results obtained are shown in Table 41 and Figs. 32-a, -b, -c.

Fig. 32-a shows the variation of the amount of water-content of Atka mackerel meat during salting, and Fig. 32-b shows that of the amount of NaCl penetrated. In Fig. 32-b the continuous lines represent the amount of NaCl penetrated into the raw sample, and the dotted lines show the amount of NaCl in percentage ratio to dried matter of the same sample.

In Fig. 32-b, the continuous lines represent the amount of NaCl penetrated into the raw sample, and the dotted lines show the amount of NaCl in percentage per dried matter of the same sample.

Fig. 32-c shows the ratio of the amount of NaCl to the sum of the amount of water-content ($m\%$) and NaCl penetrated ($s\%$), $((s/m+s) \times 100)$ in order to presume the concentration of NaCl in body fluid after Hasegawa^{40b)}.

As seen in Fig. 32-a, in curve I which shows data of the sample soaked in the most diluted NaCl solution (7.2%) the amount of water-content increased gradually until 3 hours of salting, and thereafter somewhat decreased and then

Table 41. The variations of water-content and NaCl during brine salting of Atka mackerel meat

Time (hrs.)	7.2% NaCl soln. (I)			13.7% NaCl soln. (II)			24.4% NaCl soln. (III)		
	Water-content "m" (%)	NaCl content "s" (%)	$\left(\frac{s}{m+s} \times 100\right)$	m (%)	s (%)	$\left(\frac{s}{m+s} \times 100\right)$	m (%)	s (%)	$\left(\frac{s}{m+s} \times 100\right)$
0	74.78	0.31 (1.21)	0.4	74.78	0.31 (1.21)	0.4	74.78	0.31 (1.21)	0.4
1	75.46	3.88 (15.8)	4.9	73.02	5.37 (19.8)	6.9	66.34	7.85 (23.3)	10.6
3	77.68	4.34 (19.4)	5.3	72.89	8.43 (31.1)	10.4	62.31	11.24 (29.8)	15.3
5	74.40	4.61 (18.0)	5.8	69.57	8.47 (27.8)	10.8	60.35	11.20 (28.2)	15.7
7	76.24	4.70 (19.8)	5.8	70.11	8.26 (27.6)	10.5	59.61	11.12 (27.5)	15.7

Note: The numbers in parentheses show percentage of NaCl per dried matter.

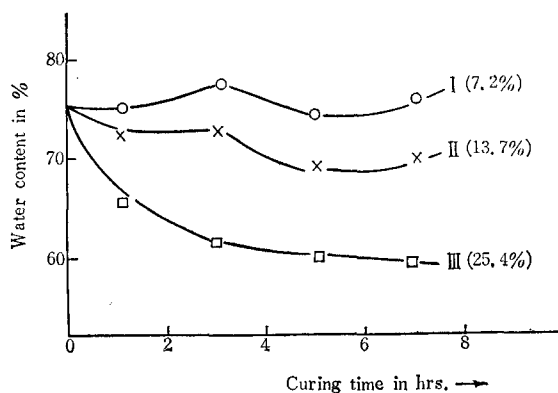

Fig. 32-a. The variation of the amount of water-content (*m*) during the salting

increased again at 7 hours' salting.

The increase of the amount of water-content in the diluted NaCl solution at initial period of salting is admitted by many investigators^{39,41}. This is recently considered to be principally due to lyotropic phenomenon of NaCl ion with water molecule.

In curve II which represents the sample soaked in 13.7% NaCl solution, the amount of water-content decreased gradually until 6 hours, and increased the same as curve I at 7 hours' salting. In curve III which shows the sample soaked in the most concentrated NaCl solution (25.4%), the increase of the amount of

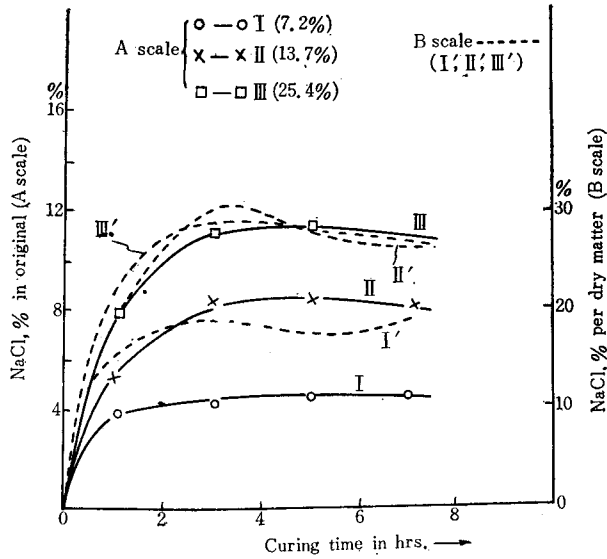

Fig. 32-b. The variation of the amount of NaCl (s) during the salting

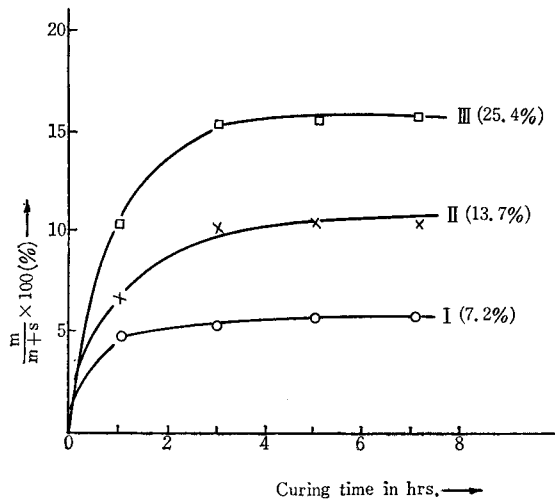

Fig. 32-c. The variation of the value of $(\frac{m}{m+s}) \times 100$ during the salting

water-content was not recognized within the time of the experiment, and it decreased from the initial period of salting. The amount of decreasing of water-content in the sample soaked in 25.4% soln., is much more than that in the samples soaked in 7.2% or 13.7% NaCl solution.

As seen in Fig. 32-b, in curves I, II and III which show the variation of the amount of NaCl in raw fish meat, the amount of NaCl increased rapidly at initial

period of salting until 3 hours, and thereafter that amount in sample which was soaked in 7.2% NaCl solution increased gradually.

The amounts of NaCl in samples which were soaked in 13.7% and 25.4% NaCl solutions reached the maximum point in about 5 hours' salting and thereafter the amount decreased somewhat until 7 hours' salting.

As to the samples soaked in 25.4% NaCl solution, the amount of water-content decreased continuously from the initial period of salting.

Therefore, the decrease of the amount of NaCl as above stated is considered to show the variation of the amount of the dried matter which is caused by the dissolution of NaCl solution soluble protein.

In Fig. 32-b, the variation of the amount of NaCl in relation to the dried matter in fish meat was shown by dotted lines, curves I', II' and III'.

In curves I', II' and III', the maximum amount of NaCl is temporarily shown at 3 hours' salting, thereafter the amount decreases and then increases. Those curves I' and II' have a tendency to correspond with curves I and II which show the variation of the amount of water-content in raw meat respectively. As to the concentration of NaCl in the body fluid, which is shown in Fig. 32-c, an apparent constant was shown in 3~4 hours; after 7 hours' salting the amount of NaCl in the body fluid of fish meat soaked in 7.2% NaCl solution was about 5.3%, in 13.7% NaCl solution, about 10.6% and in 25.4% NaCl, about 15.7%.

As above stated, after the amount of NaCl penetrated reached apparent constant in 3 hours' salting, the variation of the amount of water-content and that of NaCl penetrated in proportion to the dried matter of fish meat have the same tendency.

From the results as above obtained there is clearly a correlation between the penetrated amount of NaCl into, and the amount of the withdrawal of water from the fish meat.

That is to say, after the amount of NaCl penetrated attains apparent constant, withdrawal of body fluid to the outside of the fish meat occurs, at the same time NaCl diffuses with water to outside brine; contrarily, when water is absorbed to the inside of the fish meat, at the same time NaCl penetrates into the fish meat, so the definite ratio of NaCl to water is always kept.

However, it is noteworthy that the maximum amount of NaCl in body fluid is always less than the amount of NaCl in outside brine. As to those facts, Reay⁴¹⁾ and Hasegawa^{40b)} have obtained the same results respectively.

Hasegawa has studied the penetration of NaCl using about 4.3 gm of tuna meat. According to his observations, the amount of NaCl penetrated into the meat reached apparent constant after 20 hours' salting and did not reach the same degree of concentration of NaCl as the used brine even after 100 hours' salting.

The fact that the concentration of NaCl in the outside solution (brine) is not the same as that of NaCl in the body fluid of fish meat nor even nearly resembling it, leads to the following consideration: The total amount of water in the body fluid was not act as solvent for NaCl after the amount of NaCl penetrated attains apparent constant, and a part of the water only dissolves

Table 42. Water distribution in salted Atka mackerel meat after the penetration of NaCl attained to apparent constant

Time (hrs.)	7.2% NaCl soln. (I)				13.7% NaCl Soln. (II)				25.4% NaCl soln. (III)			
	Total Water	Free Water	Bound Water		T.W.	F.W.	B.W.		T.W.	F.W.	B.W.	
	%	%	%	"g"	%	%	%	"g"	%	%	%	"g"
3	77.7	55.8	21.9	0.98	72.9	53.0	19.9	0.74	62.3	33.0	29.3	0.78
5	74.4	59.4	15.0	0.59	69.6	53.3	16.3	0.54	60.4	32.9	27.5	0.69
7	76.2	60.6	15.6	0.69	70.1	52.3	17.8	0.59	59.6	32.6	27.0	0.67

Remarks: The concentration of NaCl in the fluid of fish meat was supposed to $(S/F.W.+S) \times 100 = 7.2\%$ or 13.7% , or 25.4% respectively.

NaCl penetrated and keeps the definite concentration in the body fluid of fish meat.

Table 42 shows the values of the theoretical amounts of Free Water and Bound Water which were calculated from the results obtained in Table 41, supposing that the penetrating amount of NaCl reaches apparent constant after 3 hours' salting and the concentration of NaCl in the body fluid is the same as that of NaCl in the outside brine.

In Table 42, the value of "g" represent the theoretical amount of Bound Water per gm of dry matter of the samples. As the concentration of the outside brine is diluted by water withdrawn from the fish meat, the practical values of the amounts of Free Water and Bound Water may differ somewhat from the values given in Table 42.

As seen in Table 42, the calculated amounts of Bound Water in fish meat soaked in A solution (7.2% NaCl solution) and B solution (13.7% NaCl) are about 15~22% in raw material, and it is about 17~30% in the fish meat soaked in C solution (25.4% NaCl). Those calculated amounts of Bound Water are 0.5~1 gm per gm of the dried matter. Those values agree with the maximum amounts of Bound Water which were estimated by the cobaltous chloride method for salted squid and mackerel meat as reported in the previous Section II.

It is impossible to discuss the variation of the amounts of Bound Water from the results as above obtained since they contain a few presumptions. However, it is clear that there is some amount of Bound Water which does not dissolve NaCl penetrated into the fish meat.

As seen in curves II' and III' of Fig. 32-b, the proportion of the increasing of NaCl relative to the dried matter of fish meat soaked in 25.4% NaCl solution was larger than that of the fish meat soaked in 13.7% NaCl solution at the initial period of salting. There was almost no difference between the amount of NaCl penetrated into the fish meat which was soaked in those two solutions after 3 hours' salting. Therefore, in this experiment, if the larger amount of NaCl penetrated into the fish meat which was soaked in higher concentration of NaCl solution, the larger amount of water is withdrawn correspondingly from the fish meat.

On the contrary, if the smaller amount of NaCl penetrated into the fish

meat which was soaked in lower concentration of NaCl solution, a smaller amount of water is withdrawn correspondingly from the fish meat. There seems always to be a definite ratio of the penetrating amount of NaCl to the amount of water withdrawn to the outside.

According to Reay⁴¹⁾, Callow⁴³⁾ and Yamada⁴⁴⁾ who have studied on the phenomenon of reabsorption of water by "Protein-salts complex", if an excessive amount of NaCl penetrates into the fish meat which was soaked in high concentration of NaCl solution, the fish meat protein peptizes and again absorbs water from outside.

In this experiment, the increasing of the amount of water-content in the fish meat soaked in 7.2% NaCl solution or 13.7% NaCl solution was recognized after 5~7 hours' salting. This agrees with the phenomenon of reabsorption of water by "Protein-salts complex". In this case, the amount of NaCl penetrated into the fish meat increases correspondingly with the reabsorption of water. The detail of this phenomenon will be discussed in the following experiment.

(2) *Experiment II*

(i) Sample; 12 Atka mackerel were viscerated and cut to fillet, and one side of the fillet was skinned.

(ii) Method of experiment

For brine salting of samples, brine of NaCl Bé 5° and Bé 11° were employed. For dry salting, solid NaCl was added to 25% of the weight of the sample. Each 7 pieces of fish fillet were employed for both salting methods. After salting each one piece was taken after 1, 2, 4, 5, 7, 9, and 11 days. About 2 gm of meat were taken from back part of the fish fillet for the estimations of the amount of water, NaCl and Bound Water.

(iii) Results of experiment and Discussion

The results obtained are shown in Table 43 and Fig. 33-a~33-d.

In every Fig., curves I, II and III show the results in brine salting Bé 5°, Bé 11° and dry salting respectively. As seen in curve I of Fig. 33-a, showing the variation of the amount of water-content during salting, the water-content in the sample soaked in brine of Bé 5° decreased slightly until the 4th day of the initial period of salting; it increased remarkably in 4~6 days period and swelled, then it decreased again after 6 days.

As seen in curve II of Fig. 33-a, the water-content in the sample soaked in brine of Bé 11° decreased rapidly to 55% in one day and showed constant values for 5 days; then it increased again after 5 days salting, and became about 77.7% after 11 days.

As seen in curve III of Fig. 33-a, the water-content in the sample by dry salting showed a tendency almost the same as curve II (brine salting, Bé 11°), but the decreasing of the water content is smaller than that of the sample soaked in the brine at Bé 11°.

Fig. 33-b shows the variation of the amount of NaCl in the original samples during the salting.

As seen in curve I of this Fig., the amount of NaCl in the sample soaked

Table 43. The variations of the amounts of water and NaCl during salting of Atka mackerel meat

Conc. of NaCl	Items	1 day	2 days	4 days	5 days	7 days	9 days	11 days	Raw meat
Bé 5°	Total Water content (%)	76.00	75.75	74.51	88.30	86.22	77.36	78.24	81.57
	Free Water content (%)	61.60	68.22	69.16	85.80	85.40	71.70	68.66	71.56
	Bound Water content (%)	14.40	7.53	5.35	2.50	0.82	5.66	9.58	10.01
	Bound Water content (g)	0.60	0.31	0.21	0.21	0.06	0.25	0.44	0.55
	NaCl (%) (S)	1.95	1.59	2.24	1.46	2.09	2.27	2.28	0.22
	NaCl per dry matter (%)	8.12	6.55	8.79	12.5	15.2	10.0	10.5	1.19
	$\left(\frac{S}{F.W.+S} \times 100\right)$ %	3.17	2.33	3.24	1.7	2.45	3.17	3.32	0.31
Bé 11°	T.W. (%)	54.95	54.29	56.56	52.22	69.68	75.72	77.68	/
	F.W. (%)	39.15	20.49	18.36	6.32	63.01	66.47	73.88	
	B.W. (%)	15.80	33.80	38.20	45.90	6.67	9.25	3.80	
	B.W. (g)	0.35	0.74	0.88	0.96	0.22	0.38	0.17	
	NaCl (S)	2.13	3.03	5.00	3.28	5.36	5.31	5.05	
	NaCl per d.m. (%)	4.73	6.44	11.5	6.86	17.7	21.8	22.6	
	$\left(\frac{S}{F.W.+S} \times 100\right)$ %	5.45	14.8	27.2	52 ?	8.5	8.0	6.84	
Dry salting	T.W. (%)	74.35	69.84	60.51	61.16	66.03	65.27	76.48	/
	F.W. (%)	58.95	57.14	38.61	47.56	63.31	53.17	67.65	
	B.W. (%)	15.40	12.50	21.90	13.60	2.72	12.1	6.80	
	B.W. (g)	0.60	0.42	0.74	0.35	0.08	0.35	0.29	
	NaCl (S)	2.07	6.41	8.34	9.27	8.21	12.16	11.32	
	NaCl per d.m. (%)	8.07	21.2	21.2	23.9	24.2	35.0	48.2	
	$\left(\frac{S}{F.W.+S} \times 100\right)$ %	3.52	11.2	14.6	19.5	13.0	22.9	16.3	

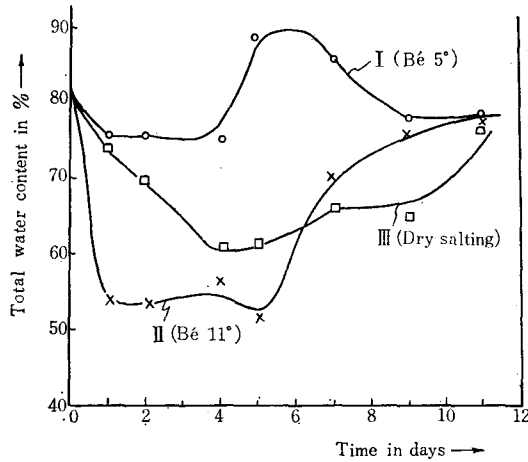

Fig. 33-a. The variation of the amount of water-content (m) during the salting

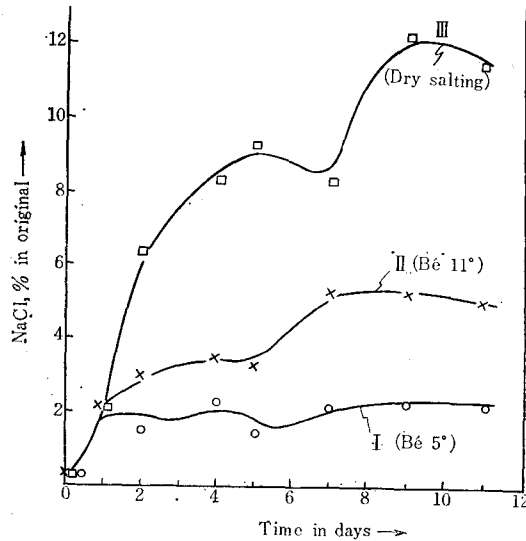

Fig. 33-b. The variation of the amount of NaCl (S) in the original samples during the salting

in brine of Bé 5° showed about 2% at first day of salting, and thereafter showed almost constant value.

As seen in curve II of Fig. 33-b, the amount of NaCl in the sample soaked brine of Bé 11° showed constant value of 3~3.5% at the 2nd~5th day of the salting, and increased to about 5.4% at the 7th day, then decreased somewhat until the 11th day.

As seen in curve III of Fig. 33-b, the amount of NaCl penetrated into the sample by dry salting was larger than that of samples which were soaked in

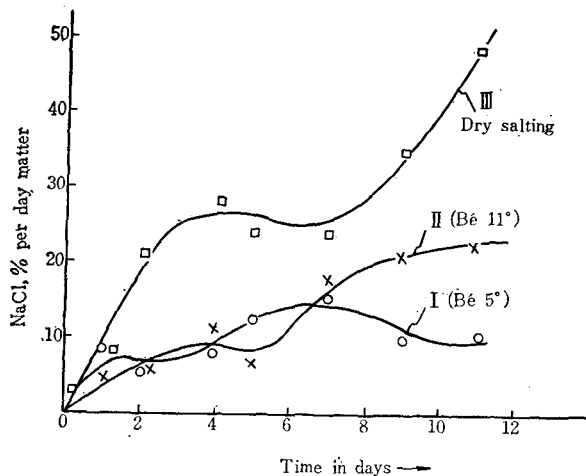

Fig. 33-c. The variation of the amount of NaCl (S) in the dried matter during the salting

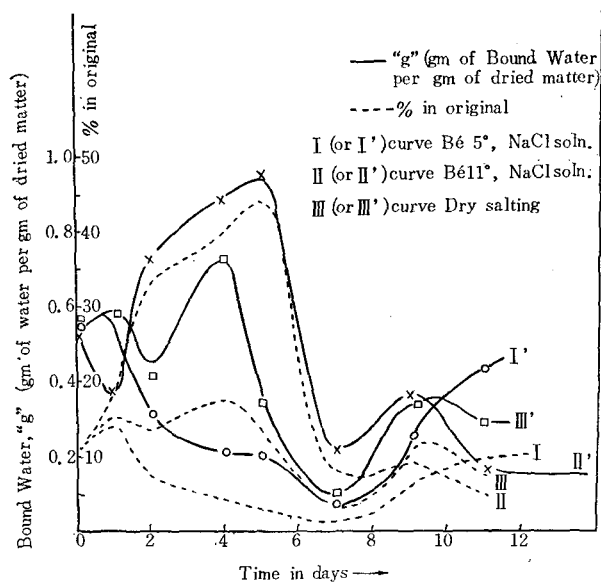

Fig. 33-d. The variation of the amount of Bound water estimated by cobaltous chloride method during the salting of Atka mackerel meat

brine of Bé 5° or Bé 11°. The tendency of the increase resembled that of the samples by brine salting. In the 4~6 days period the constant value of the first stage, about 8.2%, was shown, and at the 9th day it increased rapidly to above 12%; thereafter the amount of NaCl decreased.

Comparing Fig. 33-b with Fig. 33-a, in the case of salting of brine of Bé 11° and dry salt the amount of NaCl increased rapidly at the time of initial decreasing of the water-content, and the amount of NaCl showed first stage of constant value at the time when the water-content began to increase.

It increased at the time of increasing of the water-content and attained to the second stage of constant value of the amount of NaCl.

Fig. 33-c shows the variation of the amount of NaCl in the dried matter of fish meat during salting.

The tendency of the variations of NaCl which were shown in curves I, II and III is almost the same as that of Fig. 33-b. But curve I of Fig. 33-b which showed the variation of the amount of NaCl in the original sample soaked in brine of Bé 5° did not show any more remarkable variation than curve I of Fig. 33-c; and it showed a constant variation.

On the other hand, after 4 days period of salting, the tendency of curve I of Fig. 33-c showing the variation of the amount of NaCl in dried matter of sample was shown as parallel in comparison with that of curve I of Fig. 33-a which showed the variation of the water-content in original sample. Such a relation between curve I of Fig. 33-c and curve I of Fig. 33-a was also shown in curve II of each Fig. showing the samples soaked in brine of Bé 11° and in curve III of each Fig. of the dry salted samples.

Interpreting the results as above stated, if the reabsorption of water is due to the absorption by "Protein-salts complex" formed in the fish meat, NaCl penetrates into the meat, at the same time the infiltration of water into the fish meat from the outside solution occurs.

Therefore the larger the amount of absorbed water becomes, the larger the amount of NaCl penetrates into the fish meat.

In this case, therefore, it is impossible to consider that water only infiltrates into the fish meat, contrarily that NaCl only diffuses out.

At the initial period of salting when the dehydration from the fish meat is severe, the penetration of NaCl is clearly owing to osmotic dehydration and osmotic invasion of NaCl; finally the amount of penetrated NaCl reaches a constant. But in fish meat soaked in the brine of Bé 5°, it is considered that the increase of water-content is owing to the lyotropic phenomenon by electrolyte ion. This will be discussed later on.

Fig. 33-d shows the variation of the amount of Bound Water estimated by cobaltous chloride method during the salting of fish meat by various methods.

In the Fig. 33-d the dotted line shows the percentage of Bound water in the original sample, and the continuous line shows the absolute amount of Bound Water (*g*) per gm of the dried matter of the sample. The variation of the amount of Bound Water in the original shows the relative reverse tendency in respect to that of the total amount of water which is shown in Fig. 33-a.

As seen in curve I of Fig. 33-d which shows the fish meat soaked in the brine of Bé 5°, the amount of Bound Water increased, and the total amount of water decreased correspondingly on the first day of salting.

With 1~4 days when the total amount of water showed almost constant,

the amount of Bound Water somewhat decreased. Within 4~7 days which is in the period of increasing of the total amount of water, the amount of Bound Water decreased farther. After 7 days which is in the period of decreasing of the total amount of water, the amount of Bound Water increased again. Similar processes are indicated in curves II and III also. Therefore, each curve of Fig. 33-d which shows the variation of the amount of Bound Water in original sample corresponds to each curve of Fig. 33-a showing the variation of the total amount of water in original sample.

It seems as a peculiar property of the variation of the amount of Bound Water, that in curves II and III which show data for the samples soaked in brine of Bé 11° and dry salted respectively, the amount of Bound Water decreased at the increasing period of the total amount of water after 5 days' salting, but it increased somewhat at the 8~9th day and then decreased again at 10th day.

In curve I of Fig. 33-d, on the other hand, at the decreasing period of the total amount of water after 7 days' salting, the amount of Bound Water increased relatively.

The continuous line in Fig. 33-d which shows the variation of the absolute amount of Bound Water per gm of the dried matter resembles almost the dotted line of the variation of the amount of Bound Water in original samples.

In the previous section II the author has observed that the increase of the absolute amounts of Bound Water "g" in the salted squid and mackerel was the same as in the variation of Bound Water "g" as above stated, but in that time, the increase of that amount in salted Atka mackerel meat has not been clearly observed.

In the present experiment, the increase of the amount of Bound Water in Atka mackerel meat was clearly observed at the initial period of salting.

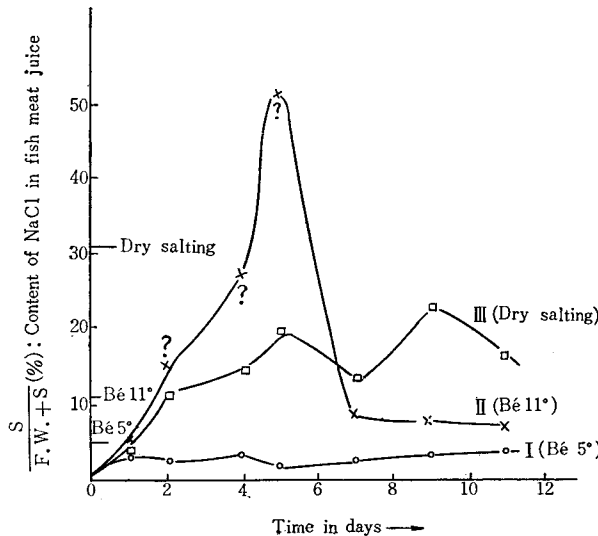

Fig. 34. The variation of the value of $(S/F.W.+S) \times 100$ during the salting of Atka mackerel meat

From the assumption that NaCl which penetrated into fish meat is not dissolved in Bound Water, but dissolves in Free Water, the author has calculated the concentration of NaCl in the body fluid of fish meat from the values written in Table 43; the results are shown in the same Table and Fig. 34.

As seen in curves I and III of Fig. 34, which represent the samples soaked in the brine of Bé 5° and dry salted respectively, the concentration of NaCl in the body fluid increased with the longer time of salting.

Moreover, that concentration of NaCl in fish meat soaked in the brine of Bé 5° showed 3.3% in maximum; the concentration in the dry-salted fish meat showed 23% in maximum.

The concentration of NaCl of the outside brine of Bé 5° is equal to about 5%. In the case of dry salting, if all the NaCl used penetrates into the fish meat the concentration of NaCl in body fluid became above 30%. The value of concentration of NaCl as above obtained is less than that of the concentration of outside solution.

As seen in curve II of Fig. 34 which is for the fish meat soaked in brine of Bé 11°, the concentration of NaCl in the meat increased remarkably to 14~52% at 2nd~5th day of salting. Supposing the concentration of NaCl in the outside solution is about 11%, the concentration of NaCl stated above seems to be abnormally high. This fact shows that the amount of Bound Water at 2nd~5th day estimated by cobaltous chloride method is too much.

The fact that the absolute amount of Bound Water per gm of the dried matter of the sample has increased in the initial period of the salting was often recognized in the previous experiments. From this fact, the abnormal phenomenon of the increase as above stated seems to be owing to the estimating conditions of Bound Water by the cobaltous chloride method.

For example, when salts are contained in the sample (containing cobaltous chloride as a kind of salt⁴⁵⁾), the value of apparent amount of Bound Water is considered to increase owing to combining ability of salt ion for the fish meat protein and the ability of the ion itself to water holding.

As seen in those experiments, on the other hand, the fact that a part of fish meat protein dissolves out into the outside solution in the initial period of brine salting and therefore the decrease of the solid matter occurs is considered to be one cause of the abnormal phenomenon of the increase of the absolute amount of Bound Water.

Therefore it may be somewhat unreasonable that the variations of the amount of Bound Water shown in each curve of Fig. 32-d should be regarded as the true variation of the amount of Bound Water.

However, when the estimated values of the amount of Bound Water for the sample soaked in the brine of Bé 11° for 2, 4 and 5 days are excepted, it is generally better to consider that the absolute amount of Bound Water "g" decreases until 7 days of salting.

In the sample soaked in the brine of Bé 11° and the sample which was dry salted, until 5 days, water withdrawn out into the outside solution. At the same time NaCl penetrated into the fish meat by osmotic action corresponding to the concentration of NaCl in outside solution, and reached to apparent

constant. During the time until that when the amount of NaCl reached the apparent constant the amount of Bound Water estimated by cobaltous chloride method increased apparently owing to the increase of the amount of NaCl penetrated and owing to the efflux of NaCl solution soluble matter from fish meat protein into the outside solution.

As the result of the accumulation of NaCl penetrated into the fish meat, it takes part in the effect of "salting out" and seems to precipitate the fish meat protein.

After the time when the amount of Bound Water reached the apparent constant, the fish meat protein peptizes and again absorbs the outside solution. At that time NaCl and water in the outside solution seem to penetrate into the fish meat in keeping with a certain definite concentration.

When the reabsorption of water occurs at the peptization of the fish meat protein, the amount of Bound Water as estimated by cobaltous chloride method seems to increase again resultant from the increase of the hydrating affinity of the peptized fish meat protein with water molecule. At the 11th day when the reabsorption phenomenon attained a constant, the apparent amount of Bound Water decreased owing to the increasing of the dehydrating power caused by NaCl penetrated.

In the case of fish meat soaked in the brine of Bé 5°, as previously stated, within the 4th day of the salting, the amount of water in the sample decreased; after the 4th day the amount increased rapidly, the fish meat came to contain a larger amount of water than that before the salting, and the meat was recognized to swell remarkably. The brine of Bé 5° contains about 5% of NaCl in the solution. Generally in such a diluted solution containing 5% NaCl (0.8 Mol), surface chemical hydration by electrolyte ion plays the leading rôle³⁹⁾. After the 4th day of the salting, the abnormal increasing of the amount of water may be due to the increase of the hydration by salt ion adsorbed on the surface of the fish meat protein peptized.

2. Conclusion

During the initial period of the salting of fish meat, the osmotic dehydration from the fish meat and penetration of NaCl in it are recognized; at the same time the apparent amount of Bound Water as estimated by cobaltous chloride method decreased. This finding seems to be due to the increase of the hydrating affinity, accompanied by the increase of salt-content in the sample or it may be due to the estimating method itself. In practice, during the time when the osmotic phenomenon is attaining a constant, the amount of Bound Water decreases owing to the increasing of the dehydrating power caused by NaCl penetrated.

During that time, the fish meat protein seems to denaturate by the effect of "salting out", and with the longer time of salting, the peptization of fish meat protein occurs. Then the apparent amount of Bound Water was recognized to increase owing to the absorption of water from the outside solution.

In case of the dilute brine, the abnormal absorption of water occurs owing to the effects of lyotropic action and surface chemical adsorption of salt ion.

VI. RELATION BETWEEN THE DECOMPOSITION OF FISH MEAT PROTEIN AND THE AMOUNT OF BOUND WATER DURING THE AUTOLYSIS OF FISH MEAT

The author has observed that the amount of Bound Water estimated by cobaltous chloride method or electrical resistance method in fish meat decreased during autolysis of putrefaction in the experiments described in Section II.

In the present experiment, the autolytic actions of raw fresh Atka mackerel meat and frozen same meat after thawing were observed. From the results obtained, the behaviour of Bound Water in the samples is discussed.

1. Experimental part

1. *The relation between the autolysis of raw fresh fish meat and of frozen fish meat and the amount of Bound Water*

Previously Amano⁴⁶⁾ has investigated the rigor motis of frozen whale meat after thawing, and observed that the glycolytic action which was stopped during the freezing of whale meat clearly recommenced at the thawing.

It is well known that the autolytic action in fish meat is very slow when the fish meat is stored at comparatively low temperatures. Particularly, even if there is some amount of Free Water in frozen material, the enzymic action is stopped entirely.

It was clearly observed that some amount of "Drip" separated owing mainly to the denaturation of fish meat protein after the thawing of frozen meat as stated in the previous Section IV. There are various types of glycolytic action during autolysis. According to Yamada⁴⁷⁾, glycogen which was considered as being combined with tissue protein phosphorates at first in that glycolysis, and at this time the amount of Bound Water varies naturally.

As seen clearly in the present author's experimental results which were previously obtained, the amount of Bound Water of frozen fish meat became less than that of the raw fresh fish meat in comparison at the same water-activity "a". Therefore the progress of autolytic action of frozen fish meat after thawing was considered to be not the same as that of raw fresh fish meat.

2. Method of experiment

In this experiment, three Atka mackerel were employed as the samples, one was employed as it was and the other two were quickly frozen at -30°C and stored during one week and two weeks at -18°C respectively. After storage, the meat was taken and homogenized with a blender and antiseptized with toluene, and left alone at $32 \pm 1^{\circ}\text{C}$.

After autolysis of the fish meat, the amounts of amino acid nitrogen (after Pope-Steven's method), volatile basic nitrogen (after Weber and Wilson), 1% NaCl soluble protein nitrogen and the value of pH of the sample were estimated at certain definite intervals. The results obtained are described below.

The chemical components of raw fresh meat of Atka mackerel employed as sample were as follows: water-content 64.86%, ash 1.04%, crude fat 16.6%, total nitrogen 2.8%, and crude protein 17.5%.

3. Results of experiment and discussion

The results obtained are shown in Tables 44~46 and Figs. 35~38.

Fig. 35 shows the variation of the values of pH during the autolysis of the samples. Fig. 36 shows the variation of the amount of 1% NaCl soluble protein nitrogen. Fig. 37 shows the variation of the amount of volatile basic nitrogen and amino acid nitrogen. In each of the Figs., curve I shows data on the sample of raw fresh Atka mackerel, curve II shows the sample which was frozen at -30°C and stored at -18°C for one week, curve III shows the sample frozen at -30°C and stored at -18°C for two weeks.

As seen in Fig. 35, in curve I of raw fresh meat, 6.8 of pH value at initial period of autolysis, decreased gradually with the lapse of time, and showed 6.15 of minimum value after 51 hours, and then increased again with the longer time of duration. From the results as above stated, it was considered that the normal glycolysis was progressing as well as raw fresh meat. In curves II or III which showed the fish meat frozen then stored for one week or two weeks respectively, no remarkable variation of the values of pH was observed as there

Table 44. Autolysis of raw Atka mackerel meat

Time (hrs.)	pH	1% NaCl-soluble-N (%)	V.B.-N (mg%)	Amino-N (mg%)	V.B.-N+Am.-N (mg%)
0	6.80	0.43	9.4	21.0	30.4
3	6.82	0.37	8.9	25.2	34.1
21	6.80	0.16	16.3	25.2	41.5
27	6.70	0.13	16.8	27.4	44.2
45	6.18	0.13	19.5	23.6	43.1
51	6.15	0.10	22.3	23.0	45.3
74	6.50	0.11	27.2	30.8	58.0
93	7.15	0.13	41.6	39.2	80.8
117	7.20	0.12	45.0	58.8	103.8
123	7.25	0.12	47.5	60.2	107.7

Table 45. Autolysis of Atka mackerel meat frozen at -30°C and stored at -18°C for one week

Time (hrs.)	pH	1% NaCl-soluble-N (%)	V.B.-N (mg%)	Amino-N (mg%)	V.B.-N+Am.-N (mg%)
0	6.86	0.34	8.9	16.0	24.9
26	7.00	0.16	9.4	24.1	33.5
27	7.10	0.12	14.2	21.0	35.2
45	6.90	0.14	23.9	23.0	46.9
51	6.80	0.15	24.9	25.2	50.1
69	6.80	0.13	25.4	24.1	49.5
75	6.70	0.10	26.4	25.6	52.0
77	6.83	0.12	35.3	26.6	62.9
93	7.10	0.13	38.3	30.8	69.1

Table 46. Autolysis of Atka mackerel meat frozen at -30°C and stored at -18°C for two weeks

Time (hrs.)	pH	1% NaCl-soluble-N (%)	V.B.-N (mg%)	Amino-N (mg%)	V.B.-N+Am.-N (mg%)
0	6.50	0.36	13.4	28.2	41.6
18	6.60	0.18	15.2	30.7	45.9
24	6.70	0.13	18.5	30.8	49.3
42	6.40	0.15	20.8	35.9	56.7
48	6.70	0.11	22.4	33.4	55.8
72	6.80	0.12	26.4	34.6	61.0
112	6.34	0.12	31.5	39.2	70.7

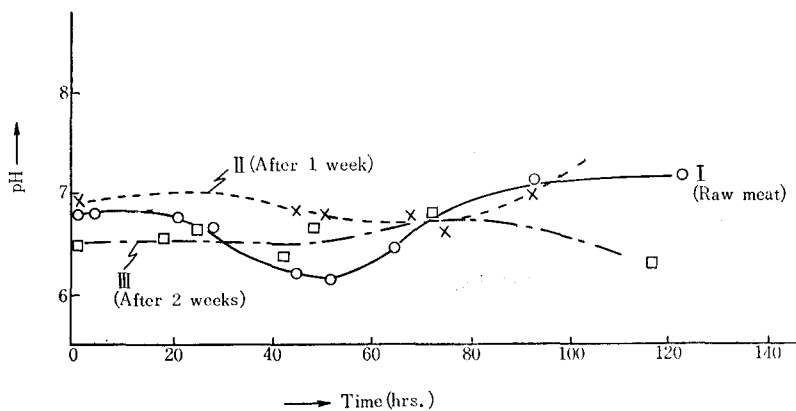

Fig. 35. Variation of pH values during autolysis of Atka mackerel meat

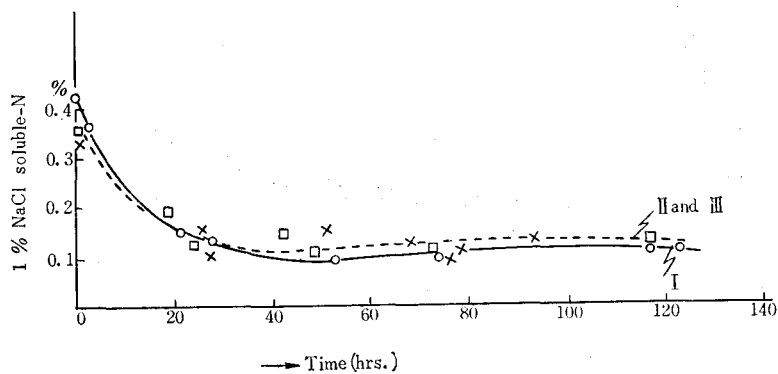

Fig. 36. Variation of the amount of 1% NaCl soluble protein nitrogen during autolysis of Atka mackerel meat

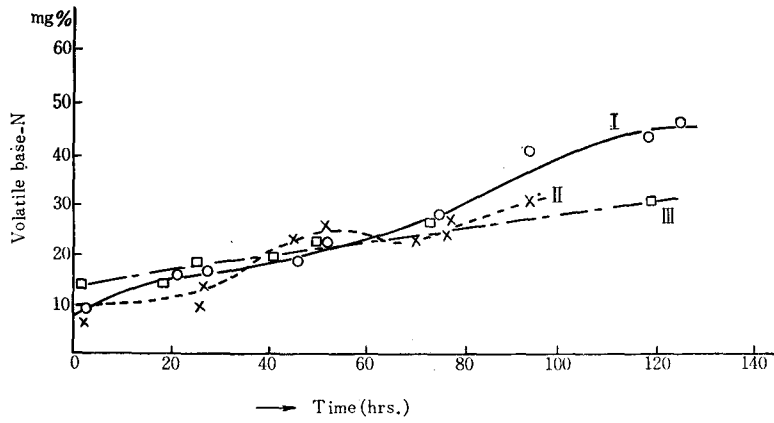

Fig. 37-a. Variation of the amount of volatile basic nitrogen

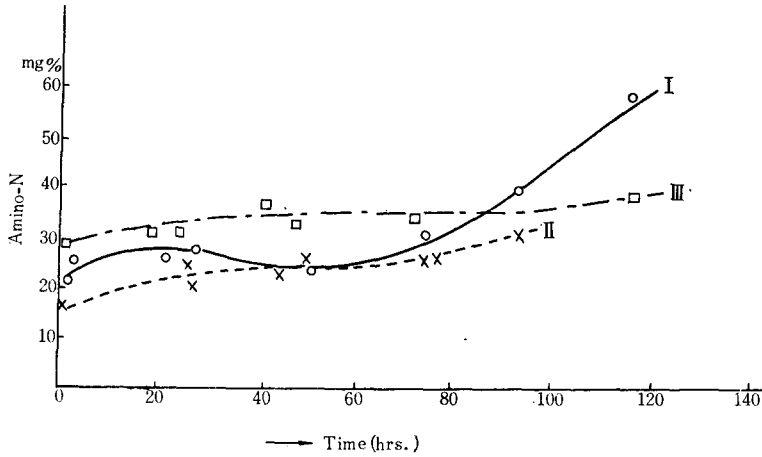

Fig. 37-b. Variation of the amount of amino acid nitrogen

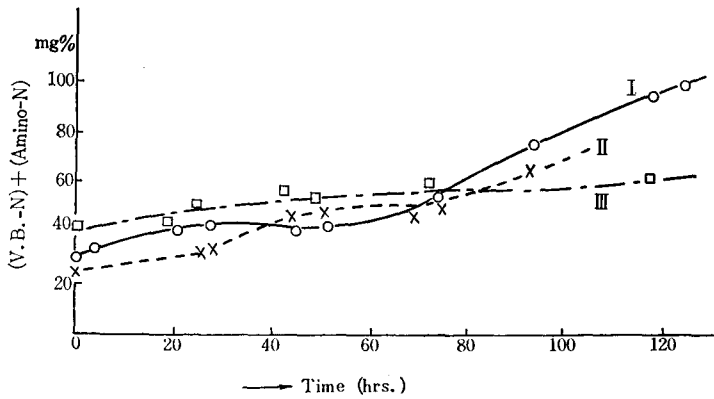

Fig. 38. Variation of the sum of volatile basic and amino acid nitrogens

was in fresh meat. Particularly, in curve III, the initial decrease of the pH value was not observed. Therefore the glycolytic action in the frozen fish meat was not recognized to progress as in the case of the raw fresh meat.

As seen in Fig. 36 showing the variation of the amount of 1% NaCl soluble protein nitrogen in frozen fish meat, the amounts showed less value than those of the raw fresh meat. This is perhaps due to the denaturation of fish meat protein during the freezing storage. After thawing, the amount of 1% NaCl soluble protein nitrogen decreased comparatively until 20 hours' autolysis, and thereafter no remarkable variation was observed with the longer duration of autolysis. Generally, the increase of the amount of 1% NaCl soluble protein nitrogen owing to decomposition of fish meat protein in putrefaction was recognized. But in autolysis, the decrease of the amount of 1% NaCl soluble protein nitrogen as above observed is perhaps due to the denaturation of fish meat protein in the various glycolytic actions such as the formation of lactic acid, the increase and decrease of A.T.P. level and the decrease of SH radical as reported by Yamada⁴⁸⁾ and Amano⁴⁶⁾.

As seen in Fig. 37-a and Fig. 37-b showing the variations of the amounts of volatile basic nitrogen and amino acid nitrogen respectively, in curve I of raw fresh fish meat, the amounts of both nitrogens increased very gradually until about 50 hours' autolysis, and thereafter increased comparatively rapidly. At that time of 50 hours' autolysis, the value of pH of raw fish meat showed the minimum value as above stated.

From the results obtained, it is considered that there are two different stages where the fish meat is decomposed separately, (1) in the decreasing period of the value of pH and (2) in the increasing period. In curves II and III which showed for the samples which were stored for one week or two weeks respectively after freezing, the increase of the amounts of both volatile basic nitrogen and amino acid nitrogen of both samples is slower than that of the raw fish meat. But the tendency of curve II seemed to be almost the same as that of curve I.

As seen in Fig. 38 which showed the variation of the sum of the amounts of volatile basic nitrogen and amino acid nitrogen, the value for frozen fish meat was less than that for the raw fish meat.

Here, autolytic velocity constant (K) was calculated by applying monomolecular autocatalytic reaction equation (9) after Kimata⁴⁹⁾:

$$\log y/A - y = Kt + c \quad (9)$$

where A is the maximum amount of the sum of volatile basic nitrogen and amino acid nitrogen produced, y is the amount of increase at every time " t " and c is a constant.

The value of $K \times 10^4$ was 202 for the samples of both the raw fish meat and the frozen fish meat stored one week. The value of $K \times 10^4$ was 157 for the sample of frozen fish meat stored two weeks. From the values obtained, it was recognized that the longer the storing time became, the less the autolytic velocity constant was.

From the results just described the decomposing velocity of fish meat protein

by autolysis for the frozen sample is clearly slower than that for the raw sample. The reason for the difference as stated is due to the denaturation of the substrate (the denaturation of fish meat protein) or to the decreasing of enzymic action by the freezing. But, generally, it is recognized that the enzymic action which has been restrained by lower temperature is brought back to normal action when the surrounding temperature become favorable. Therefore the difference of the values of autolytic velocity constant as above stated is perhaps mainly due to the denaturation of fish meat protein.

This is conducted from the previous experimental results IV, that water in the frozen fish meat has less differential molal free energy than that in the raw fish meat, therefore the amount of Bound Water in the frozen fish meat (molecular theoretical Bound Water having the same water-activity as water in the raw fish meat) is less than that in the raw fish meat. That is to say, the amount of Free Water in the frozen fish meat is much greater than that in the raw fish meat, and the frozen fish seems to have lyophobic properties (This was clearly recognized in Tarr's results³¹).

Considering from the study of Sponsler, Bath and Ellis²⁰, in the raw fish meat within the amount of the water-content regarded as molecular theoretical Bound Water "g", three molecules of water seem to be combined with amino radical, four molecules of water with carboxyl radical, three molecules with hydroxyl radical and two molecules with imino radical.

On the other hand, in the frozen fish meat, within the same amount of the water-content "g", much water whose molecules seem to be distributed as above stated, accumulated on the surface of radicals as stated.

As the result, the layer of hydration on the surface of protein molecule increases, and the number of polar radicals decreased, therefore, the frozen fish meat is less decomposable by enzyme than raw fish meat.

In consequence of various glycolytic actions in the autolysis of raw fish meat and the frozen fish which was stored for one week, in the variations of the values of pH or the amounts of volatile basic nitrogen and amino acid nitrogen, there seem to be two stages being separated that within, and that after the period 50 hours' autolysis. In the first stage the enzymic action is slow.

As Yamada⁴⁷ stated, if the increase or decrease of lactic acid and the increase of inorganic phosphorus in the glycolytic action are considered the apparent amount of Bound Water seemed to increase in the first stage of autolysis and to decrease in the second stage with the longer time of the decomposition of fish meat protein.

2. Conclusion

From results obtained, it is clear that various phenomena in autolytic action which are observed in raw fish meat are restrained without disappearance during the freezing storage of fish meat.

The duration and the strength of the autolytic action is clearly different with the kind of fish, therefore various factors concerning the autolysis will be kept or not during the freezing storage differing from the kinds of fish. With the denaturation of fish meat protein by the longer time of freezing storage, the

various phenomena in autolytic action will vary when the frozen fish meat is thawed, and the apparent amount of Bound Water seemed to increase in the first stage of autolysis and to decrease in the second stage with the longer time of the decomposition of fish meat protein.

VII. GENERAL DISCUSSION

As to Bound Water, there are nowadays three definitions^{1a)}: "biological Bound Water" which is studied from the standpoint of biology and physiology, "colloidal Bound Water" from the standpoint of colloidal chemistry and "molecular theoretical Bound Water" in the molecular theory. Generally speaking, "biological Bound Water" means the minimum amount of water-content in living matters necessary to maintain their lives; "colloidal Bound Water" may be interpreted as water which necessary to maintain the stable colloidal systems, "molecular theoretical Bound Water" may be taken to mean the amount of water-content to maintain the the stable construction in protein molecules which is a main component of fish muscle.

Recently, Kuprianoff⁵⁰⁾ has discussed on "Bound Water in Foods", in which he suggested that generally there is no "free water" in foods, the water present is always "bound" in some way to one or other of its components. According to his opinion, only "surface water" on foods which comes from outside by water condensation or washing, *etc.*, could be considered as "true free water" so long as it has not mixed or reacted in any way with the surface components.

The water in foods, except "surface water" stated above, is a complex matter and depends on many different factors, and the complex water solution present in solid foods may not be bound to colloid particle by hydration, but also adsorbed on the intercellular surfaces and in internal capillaries; and different solutions with different concentrations could be present at different points as long as the structure of the product is not damaged or disrupted.

As far as the water in foods concerned, it may be true; but the next difficulty in the definition of Bound Water arises because it is based on the method used for determination. Which to use among those conceptions on Bound Water as stated above, should be chosen from the samples to be used (including living things), the purposes of the studies and method of estimating the amount of Bound Water in each special field.

In the present paper, following on the historical advancement of Bound Water research, the author has studied the behaviour and the properties of Bound Water in the muscle of fish, mollusc and crustacean (after death) on the basis of the definitions of "colloidal Bound Water" and "molecular theoretical Bound Water" as above described.

In these studies, the author has employed the cobaltous chloride method offered by Hatschek^{14a)} (Hatschek's method) and later modified by Oyagi^{14b)} (Oyagi's method), in making estimates of Bound Water in fish muscle.

By the use of those methods, estimate are made of the maximum value of the amount of Bound Water at the point B.P. where the color of a piece of dyed

sample turns to pure blue from pink in the course of drying at 25°~30°C and of the minimum value of the amount of Bound Water at the point C.P. where the apparent constant weight of water in the sample is recognized in the same course of drying. The difference of the amount of water-content between those values of the maximum and the minimum amounts was recognized to agree with the amount of Bound Water which was colloidal-chemically estimated by the freezing method, solvent methods or other thermodynamic methods. This is considered correct for the reason that by both Hatschek's and Oyagi's method Bound Water having 0.8~0.7 of the value of the water-activity in the sample can be estimated, and on the other hand by the freezing method, solvent methods and other thermodynamic methods, water having almost the same water-activity value also can be estimated^{1a)}.

Next, the present author has employed the method of estimation by electrical resistance (50 cycle resistance), and studied the relation between the amount of the water-content and the electrical resistance. The following results were obtained: With the initial decrease of the water-content in fish muscle, the electrical resistance decreased gradually. But, it began to increase rapidly in the range of 50~30% of the total water-content, which water is regarded as colloidal Bound Water; it increased more rapidly in the range of 30~20% and below 20%, which water is regarded as molecular theoretical Bound Water, the relation between the electrical resistance and the water-content showed logarithmically linear.

From the estimated value of the electrical resistance, the amount of Bound Water can comparatively easily be approximated (II).

It seems very important to examine the behaviour of Bound Water in the fish meat during the process of manufacture until it is offered as merchandise. The author has studied the subject employing the cobaltous chloride method (Oyagi's method) which can be used to estimate colloidal Bound Water, because he believes that colloidal Bound Water plays particularly important roles in the fish meat technology.

Fresh raw meat of various kinds of fish contains Bound Water of 55~82 gm per 100 gm of dried matter in maximum and 10~48 gm in minimum. When those fresh meats are naturally dried, and if Free Water only is considered to evaporate at the initial period of the drying, and at the time when the total water-content becomes 20~40% of the weight of the original matter, all the water in the dried fish meat is regarded as Bound Water. When the fresh meats of squid and Atka mackerel and other fish were dried in the room temperature, as expected, with the decrease of the total water-content in the fish meat the amount of Bound Water increased relatively; at the time when the total water-content became about 40~50%, the increase of the amount of Bound Water showed the maximum value; in the further drying, with the decrease of the total water-content, the amount of Bound Water was observed also to decrease. In this case, the binding strength of the remaining water increased with the decrease of the total water-content, and the absolute amount of Bound Water per gm of the dried matter also gradually decreased.

When the results obtained by Higuchi¹²⁾ for the meat of squid and flat fish

having various water-content by the calorimetric method and the freezing method were compared with the minimum amount of Bound Water as obtained by the present author, using Oyagi's method, both results were recognized to be agreeable. Because of such thermodynamic methods, *e.g.*, calorimetric method and freezing method are generally used for determination of Bound Water from the standpoint of colloidal chemistry, this agreement as stated above encourages the present author to believe that the minimum amount of Bound Water estimated by the cobaltous chloride method should be considered as the colloidal Bound Water.

When the salt solution is dense and the osmotic dehydrating action is promoted in the salting of fish meat, with the decreasing of Free Water accompanied with the decreasing of the total water-content, the amount of Bound Water (% in the original matter) decreased or increased relatively. In this case, some loss of the dried matter caused by dissolving out of soluble protein occur as accompanying phenomena. Therefore the change of the absolute amount of Bound Water can not be known, but according to the general examination of the results (V) which were obtained lately, it became clear that the absolute amount of Bound Water increased in the initial period of the salting, and it decreased in the final period of the salting by the denaturation of fish meat protein caused by the effect of "salting out" accompanying with the condensation of salt in muscle fluid. The increase of the amount of Bound Water in the initial period of the salting may be explained as follows: the lyotropic hydration phenomenon occurs while the amount of the salt penetrated into the sample is little and the estimating method itself gives the larger value of the amount of Bound Water and furthermore the dried matter decreases rapidly in the initial period of the salting.

When the salting solution is dilute, as a result of "salting in" effect, surface chemical adsorption of salt ion occurs rather than the osmotic action, and the absorption of abnormal amount of water was observed. Those facts are in agreement with Yamamoto's result³⁹⁾ obtained from the studies of the relation between the penetration of water through the frog's skin and the concentration of the salt solution. In the final period of the salting using the conc. solution of the salt, the phenomenon of reabsorbing water by the salt-protein complex, which has been studied by Reay⁴¹⁾ and other investigators⁴³⁾, was also observed by the present author. When the phenomenon which is considered to be the peptization of protein occurs, absorption of water from the outside NaCl solution is observed, and at the same time NaCl also penetrates into the fish meat muscle. At this time the amount of Bound Water was apparently observed to increase. From the compared results obtained by electrical resistance which were estimated between the fresh fish meat and salted fish meat having various amounts of water-content, a part of Bound Water having weak binding strength with fish meat protein is suggested to hydrate with electrolyte as Free Water.

During the fermentation and putrefaction of fish meat, the amount of Free Water increased while that of Bound Water decreased relatively. Those results were observed to be opposed to the results obtained in the drying or salting. It was difficult to estimate accurately the amount of Bound Water in

the fermented or putrefied meat by the cobaltous chloride method, because those meat muscle became soft and the amount of the dried matter varied in the course of the decomposition of the fish meat. Therefore the method by electrical resistance was employed for the estimation of Bound Water in such fermented or putrefied meat. According to the results obtained, when the fresh fish meat and putrefied fish meat were dried, the electrical resistance decreased with the initial decreasing of the water-content, but thereafter it increased rapidly with the decreasing of the water-content. In this case, when the putrefied fish meat was dried, it showed lower value of the electrical resistance than the dried fresh meat without putrefaction at the same water-content. From those results, it became clear that with the decomposition of fish meat muscle by putrefaction, Bound Water was weakened in its binding strength by the movement of electric charge, and the binding strength of water in the muscle tissue loosened (II).

From the previous experimental results for the dried fish meat, it was considered that in accordance with the drying, the relative amount of Bound Water increased and at last water in fish meat was only that water which is regarded as Bound Water. Therefore the author has studied the influence of the amount of Bound Water upon the velocity of drying for 12 kinds of fish meat mainly by the vapour tension method and the cobaltous chloride method. The results obtained were analyzed theoretically by B.E.T. method²³⁾. In this case the samples were dried at 35°~40°C in order to avoid the denaturation by heat coagulation of fish meat protein. At 35°~40°C the velocity of drying decreased remarkably in the range of the water-content of molecular theoretical Bound Water, *i.e.* the stage of drying was observed to reach apparently the 2nd stage of falling rate of drying. However, in the course of commercial drying by sun light at lower temperature, it is considered that the water-content in the fish meat reaches readily to the equilibrium in the range of the water-content of colloidal Bound Water rather than in that of molecular theoretical Bound Water. Considering from the fact that the preservability of the dried goods is owing to the lower content of water in the goods, Bound Water in the fish meat is considered to be unavailable to bacteria as a nutrient (III).

As to "Drip" in the frozen meat and fish meat, the author has studied its cause. According to the results obtained, with the falling of the freshness of fish meat, the amount of "Drip" in the quickly frozen fish meat increased gradually, when the frozen meat was stored longer, owing to the denaturation of protein. In this case it was observed that a part of water which has been estimated as "Expressible drip" in the initial period of storage has changed to "Free drip" with the lapse of storage time. As the value of differential molal free energy, $\Delta\bar{F}$, of the molecular theoretical Bound Water in the frozen and stored fish meat was less than that of fresh fish meat at the same water-content, the principal cause of the formation of "Drip" is considered to be that a part of molecular theoretical Bound Water in fish meat is set free by the dehydrating denaturation of fish meat protein (or by the denaturation owing to the condensation of salts in fish meat protein⁵¹⁾).

Accepting the above consideration, if some method of increasing the value of $\Delta\bar{F}$ can be found for raw fish meat, it would seem possible to prevent to a

certain degree the decrease of value of $\Delta\bar{F}$ during freezing and storage. Thus the good frozen foods as well as nutritiously fresh raw fish meat would be obtained.

The effect of the preventing method of the formation of "Drip" by changing of pH value of the fish meat to the alkali side (Taylor's method³⁴) or the method of soaking fish meat in the NaCl solution offered by Tarr³¹) were experimentally clarified to be due to the increase of the value of $\Delta\bar{F}$ in raw fish meat before the freezing.

The remained water in fish meat after the separation of "Drip" showed a higher value of $\Delta\bar{F}$ than that of water in frozen fish meat left as it is, therefore it seems that water after the separation of "Drip" has stronger binding power. One of the principal causes of the formation of "Drip" seems to be the denaturation of frozen fish meat protein, which denaturation brings change in the amount of Bound Water and weakens the binding power.

According to the experiment of Tarr, the higher degree of swelling of salt solution is employed, the larger the holding ability of water is, even if it is the same kind of salt, *i.e.*, the larger the preventing effect of the formation of "Drip" is. The present author has studied the swelling effect of various kinds of salt upon Atka mackerel meat, and learned that potassium salts is the most suitable substance for the prevention of the formation of "Drip" in a concentration of about 0.6 Mol (IV).

Finally, the present author has compared the autolysis of fresh raw fish meat with that of frozen fish meat. The factors concerned with autolysis were kept during the freezing storage, however the factors became less potent with the lapse of the storing time. The principal cause is owing to the denaturation of fish meat protein accompanied with the decrease of the amount of molecular theoretical Bound Water during the freezing storage.

In the glycolytic action of the fish meat, as Yamada⁴⁷) stated, with the increase of the amount of inorganic phosphorus the amount of Bound Water seems to increase. In the course of decomposition after the glycolysis, the amount of Bound Water seems to decrease. The duration time and the degree of glycolytic action are different with the kind of fish meat, therefore the factors concerned with glycolytic action during the freezing storage seemed to keep or not dependent upon the kinds of fish (VI).

VIII. SUMMARY

There are three definitions for Bound Water up to date; "biological Bound Water" from the stand-point of biology, "colloidal Bound Water" from colloidal chemistry, and "molecular theoretical Bound Water" from the molecular theory. Those definitions should be differentiated by the samples (including living matters) in various applied fields, by methods of estimation and by purposes of the studies.

In the present paper, Bound Water in the fish muscle (including mollusc and crustacean) after death was studied from the stand-points of colloidal chemistry and molecular theory.

As the method for estimating the amount of Bound Water, the author has employed (1) the cobaltous chloride methods which were offered by Hatschek at first and later on modified by Oyagi, (2) the vapour tension method, and (3) the method by electrical resistance.

As samples, the author first used the various kinds of fish and he has estimated the amount of Bound Water by the cobaltous chloride method (Oyagi's method) and by the electrical resistance method.

Next, the influence of Bound Water upon the drying velocity was studied by using 12 kinds of fish including mollusc and crustacean.

The relation between the formation of "Drip" and the amount of Bound Water during the refrigeration of fish meat was studied using Atka mackerel.

The variation of the amount of Bound Water during the process of salting of fish meat was also studied using Atka mackerel.

Last, the relation between the decomposition of fish meat protein and the amount of Bound Water during autolysis was studied.

The results obtained may be summarized as follows;

(1) Bound Water estimated by the cobaltous chloride method is to be regarded mostly as "colloidal Bound Water".

(2) The hydration of NaCl with fish meat protein is affected from the binding strength of Bound Water with fish meat protein.

(3) With the decrease of the amount of water, the electrical resistance of 50 cycles increases gradually; it increases rapidly in the range of the water-content which was regarded as "colloidal Bound Water", and it increases logarithmically in the range of the water-content which was regarded as "molecular theoretical Bound Water".

(4) On the curve of the water-content—water-activity estimated by the vapour tension method, the water which has below 0.7 of the value of the water-activity is to be regarded as "molecular theoretical Bound Water".

(5) In fresh raw fish meat, 55~82 gm of "colloidal Bound Water" is generally contained in 100 gm of the dried matter in the maximum amount, and 10~48 gm in the minimum amount.

(6) In the course of drying of fish meat, the maximum amount of Bound Water is found at the time when the total amount of the water-content in fish meat reaches to 40~50%, and the absolute amount of Bound Water decreases with the decrease of the total water-content.

(7) In the salting of fish meat, the amount of Bound Water increases apparently in the initial period of salting, and longer the salting time is, the less the amount of Bound Water is found to be. However, the amount of Bound Water apparently increases again in the final period of the salting when the fish meat protein peptizates and absorbs water. The increase of the water-content at the final period of the salting is said to be owing to the phenomenon of absorption by "salt-protein complex". In this case, when water is absorbed by fish meat from the outside solution, NaCl penetrates into the meat at the same time, and the mere apparent absorption of salt solution seems to occur.

In the case of salting by diluted NaCl solution, it may occur that the amount

of the water-content increases remarkably by the lyotropic action of electrolyte ion.

(8) With the decomposition of fish meat in fermentation or putrefaction, the electrical resistance decreases, and the amount of Bound Water decreases also.

(9) In the case of the drying of fish meat at 40°C, the drying velocity decreases remarkably in the range of the amount of water-content of fish meat which is regarded as to be contained in "molecular theoretical Bound Water". Under the natural drying conditions in the manufacture of commercial dried fish, the presence of "colloidal Bound Water" seems to inhibit remarkably the drying velocity.

(10) During the storage of frozen fish meat, "molecular theoretical Bound Water" is set free and the value of $\Delta\bar{F}$ decreases corresponding to the denaturation of the fish meat protein, which is a principal cause of the formation of "Drip".

If the increasing of the value of $\Delta\bar{F}$ is previously devised in the fish meat, it is possible to prevent the formation of "Drip". Practically the method of soaking fish meat in NaCl solution, or in solution of which the pH value is adequate, can prevent the formation of "Drip".

(11) In the glycolytic period during the autolysis of fish meat, the amount of Bound Water seems to increase and in the period of decomposition of fish meat, the amount seems to decrease.

(12) During the storage of frozen fish meat, various factors concerned with autolysis are somewhat kept as they are, but the longer the storage period of refrigeration becomes, the slower the factors act accompanying with the denaturation of fish meat protein.

LITERATURE CITED

1. (a) Akiba, M. (1951). *Bull. Fac. Fish. Hokkaido Univ.* 1 (3-4), 156.
 (b) ——— (1951). *Ibid.* 2 (3), 176.
 (c) ——— & Hirota, K. (1950). *Kagaku* ("Science") 20 (12), 572.
 (d) Hirota, K. & Akiba, M. (1951). *Bull. Res. Inst. of Applied Electricity, Hokkaido Univ.* 3 (2), 87.
2. (a) Higashi, K. (1947). *Kagaku* ("Science") 17 (5), 120.
 (b) ——— & Takeda, S. (1947). *Ibid.* 17 (3), 82.
 (c) ——— & Nukazawa, K. (1948). *Kagaku-no-Kenkyu* ("Chemical researches"), 1, Biochemistry, 23.
3. Thoenes, F. (1925). *Biochem. Zeitsch.* 157, 174.
4. Hardy, Wm. *Kolloid. Z.* 46, (1923); *Proc. Roy. Soc.* 112, 47 (1926).
5. (a) Moran, T. (1932). *Proc. Roy. Soc. A* 112, 30.
 (b) ——— (1932). *Rep. Food Inv. Board* 33.
 (c) ——— (1958). *Proc. Roy. Soc. B* 118, 548.
6. Kinoshita, K. (1930). *Jour. Chem. Soc. of Japan* 5, 261.
7. Kistler, S. S. (1936). *Jour. Am. Chem. Soc.* 58 (6), 901.
8. Plank, R. (1932). *Z. ges. Kälte- Ind.* 39 (4).
9. Heiss, R. (1935). *Z. Electrochem.* 41, 250.

10. Joslyn, M. A. (1940). *Ice and Refrigeration* 99 (2), 63.
11. (a) Gortner, R. A. & the Hoffman, W. F. (1922). *Botan. Gaz.* 74, 308.
(b) Newton, R. & Gortner, R. A. (1922). *Ibid.* 74, 422.
12. Higuchi, K. (1945). *Kanzume-jiho* ("The Canned Food Times") 24 (4), 8.
13. Kawakami, T. (1935). *Bull. Jap. Soc. Sci. Fish.* 4 (1), 125.
14. (a) Hatschek, E. (1936). *Trans. Faraday Soc.* 32, 787.
(b) Oyagi, Y. (1949). *Lecture of the Chem. Soc. of Japan.*
15. Katz, J. R. (1917). *Colloid-chem. Beih.* 9, 1.
16. Brooks, J. (1934). *Proc. Roy. Soc. B* 114, 258.
17. (a) Briggs, D. R. (1931). *Jour. Phys. Chem.* 35, 2914.
(b) ——— (1932). *Ibid.* 36, 367.
18. Herrmann, K., Gerngross, O. & Abitz, W. (1930). *Z. Chem.* 10, 371.
19. Katz, J. R. & Derksen, J. C. (1932). *Rec. Trav. Chim.* 51, 513.
20. Sponsler, O. L., Bath, J. D. & Ellis, J. W. (1940). *Jour. Phys. Chem.* 44, 996.
21. Adair, G. S. & Callow, E. H. (1930). *Jour. Gen. Physiol.* 13, 819.
22. Bull. H. B. (1944). *Jour. Am. Chem. Soc.* 66, 1499.
23. (a) Brunauer, S., Emmett, P. H. & Teller, E. (1938). *Ibid.* 60, 309.
(b) Keii, T. (1950). *Shokubai* ("Catalyst") 6, 40.
(c) Suga, T. (1950). *Kagaku-to-Kogyo* ("Chemistry and Chemical Industry") 3 (12), 387.
24. Tanikawa, E. (1943). *Enzo-Shokuhin* ("Salted Foods"). 37, Tokyo; Seikatsu-sha.
25. (a) Ueda, D. *et al.* (1935). *Denki-Hyoron* ("Journal of Electricity") 23 (4), 365.
(b) Tamura, K. (1932). *Bull. Jap. Soc. Sci. Fish.* 1 (4), 168.
(c) Yamamura, Y. (1941). *Ibid.* 10 (2), 83.
(d) Tamura, K., Miyazaki, T. & Kaziyama, I. (1933). *Suisan-Seizo-Kaishi* 1, 121.
(e) Callow, E. H. (1925). *Rep. Food Inv. Board.* 57.
(f) Yamada, K. & Kitano, F. (1948). *Bull. Jap. Soc. Sci. Fish.* 13 (6), 232.
(g) Ito, H., Kyojuka, N. & Sugizaki, C. (1949). *Jour. Agr. Chem. of Japan.* 23, 192.
26. Amano, K. & Uchiyama, H. (1948). *Bull. Jap. Soc. Sci. Fish.*, 14 (1), 48.
27. Fujiwara, S., Tsuda, K. & Yasui, S. (1913). *Jour. Imp. Fish. Inst.* 8 (8), 321.
28. Inoue, N. (1937). *Bull. Jap. Soc. Sci. Fish.* 6 (4), 187.
29. Kawakami, T. (1950). *Paper on the "Physical study on Fish Drying"*.
30. Tanikawa, E. & Akiba, M. (1952). *Reizo-no-kagaku* ("Science of Cold Storage"). 248 p. Tokyo; Kōbundo.
31. Tarr, H. L. A. (1942). *Jour. Fish. Res. Bd. Canada*, 5 (5), 141.
32. *Rep of the Korean Fish. Exp. St.* (1931).
33. Moran, T. (1932). *Jour. Soc. Chem. and Ind.* 51, 20 T.
34. Taylor, G. L. (1930). *Ice and Refrigeration* 79.
35. Lloyd, D. J. *et al.* (1933). *Trans. Faraday Soc.* 29, 132; *Ibid.* 554; *Ibid.* 1228.
36. Finn, D. B. (1932). *Proc. Roy. Soc. B* 111, 396.
37. Samejima, M. (1952). *Gendai-Koshitsugaku-no-tenbo* 1 ("Reviews of the Modern Colloidal Chemistry"). Tokyo; Gakujutsu-tosho-shuppansha.
38. Migita, M. & Okada, M. (1952). *Bull. Jap. Soc. Sci. Fish.* 18 (3), 25; *Ibid.* 18 (4), 21.
39. Yamamoto, K. (1949). *Seitai-no-Kagaku* ("Science of Living Body") (3), 45.
40. (a) Tanikawa, E. (1943). *Enzo-Shokuhin* ("Salted Foods"). 40 p, Tokyo; Seikatsu-sha.
(b) Hasegawa, T. (1939). *Bull. Jap. Soc. Sci. Fish.* 7 (6), 339.
41. Reay, G. A. (1936). *Jour. Soc. Chem. and Ind.* 55, 309 T.
42. Ruzsnyák, S. (1921). *Biochem. Z.* 114, 23.
43. Callow, E. H. (1932). *Rep. Food Inv. Board* 101.
44. Yamada, K. (1948). *Bull. Jap. Soc. Sci. Fish.* 13 (4), 113.
45. Kimoto, E. *et al.* (1951). *Igaku-to-Seibutsugaku* ("Medicine and Biology") 20 (3), 110.

46. Amano, K. (1953). *Bull. Jap. Soc. Sci. Fish.* 18 (10), 164.
47. Yamada, K. (1952). *Koso* ("Enzyme"). 345 p, Edited by Sakaguchi, K. and Asai, Y., Tokyo; Asakurashoten.
48. Yamada, K. (1948). *Bull. Jap. Soc. Sci. Fish.* 14 (1), 23.
49. Kimata, M. (1941). *Jour. Imp. Fish. Inst.* 34 (2), 116.
50. Kuprianoff, J. (1958). *Soc. Chem. Ind.* 14.
51. Simidu, W. & Hibiki, S. (1952). *Bull. Jap. Soc. Sci. Fish.* 17 (10), 13.