



HOKKAIDO UNIVERSITY

Title	ON THE RELATION BETWEEN THE HOMING MIGRATION OF THE WESTERN ALASKA SOCKEYE SALMON ONCORHYNCHUS NERKA (WALBAUM) AND OCEANIC CONDITIONS IN THE EASTERN BERING SEA
Author(s)	FUJII, Takeji
Citation	MEMOIRS OF THE FACULTY OF FISHERIES HOKKAIDO UNIVERSITY, 22(2), 99-191
Issue Date	1975-03
Doc URL	https://hdl.handle.net/2115/21858
Type	departmental bulletin paper
File Information	22(2)_P99-191.pdf



ON THE RELATION BETWEEN THE HOMING MIGRATION OF THE
WESTERN ALASKA SOCKEYE SALMON *ONCORHYNCHUS NERKA*
(WALBAUM) AND OCEANIC CONDITIONS IN THE
EASTERN BERING SEA

Takeji FUJII

Faculty of Fisheries, Hokkaido University, Hakodate, Japan

Contents

	page
I. Introduction	100
II. Review of studies on the western Alaska sockeye salmon and on the oceanographic structure of the sea in which the fish migrate	104
III. Surveying methods and data	118
III-1. Data obtained	120
III-1-1. Data of oceanographic observation	120
III-1-2. Data on the distribution of the genus <i>Oncorhynchus</i> and the biological statistics	123
III-2. Oceanographic survey	124
III-3. Fishing gear used for fish sampling	124
III-3-1. The kinds of mesh of gillnets and their arrangement	124
III-4. Biological investigation	126
IV. Mechanism of homing migration of the western Alaska sockeye salmon	261
IV-1. Reason for the short residence time of sockeye salmon south of the Aleutian Islands	126
IV-2. Mechanism of passing of sockeye salmon through the channels or passes	130
IV-3. Oceanographic conditions in the basin portion of the Bering Sea and behavior of sockeye salmon	131
IV-3-1. Oceanographic conditions in the basin portion of the eastern Bering Sea	131
IV-3-2. The behavior of sockeye salmon in the basin portion of the Bering Sea	143
IV-4. Oceanographic conditions over the continental slope area of the eastern Bering Sea and the behavior of sockeye salmon	146
IV-5. Oceanographic conditions over the continental shelf area and the behavior of sockeye salmon	153
IV-5-1. Oceanographic conditions over the continental shelf area	153
IV-5-2. Behavior of sockeye salmon in the continental shelf area	157
V. General discussion	160
V-1. Relation between the entering of sockeye salmon into the Bering Sea passing through channels or passes and the oceanographic conditions	160
V-2. Relation between the northward distribution of western Alaska sockeye salmon in the basin area and the oceanographic conditions	164

V-3.	Relation between the distribution and the migration of sockeye salmon in the continental slope area and the oceanographic conditions	165
V-4.	The distribution of western Alaska sockeye salmon in the continental shelf area and the oceanographic conditions	166
V-5.	Migrating routes of the western Alaska sockeye salmon classified by mother rivers	169
V-6.	The distribution of western Alaska sockeye salmon and fork length	173
V-7.	Relation between the migrating route of the western Alaska sockeye salmon into Bristol Bay from the south side of the Aleutian Islands and the water temperature and salinity	174
V-8.	Change of the gonad weight during the migration of the western Alaska sockeye salmon from the south side of the Aleutian Islands	175
V-9.	Relation between the sockeye salmon offshore fishery of western Alaska and oceanographic conditions in the Aleutian Islands area	177
VI.	Conclusion	178
VII.	Acknowledgements	181
VIII.	Summary	182
	References	184
	Appendix	188

I. Introduction

There are six species of the genus of *Oncorhynchus* living in the north Pacific Ocean and adjoining sea areas. The fish are sought in the north Pacific Ocean north of the polar front, the Bering Sea, the Sea of Okhotsk, and the Sea of Japan.

The principal fishing countries are U.S.S.R., U.S.A., Canada and Japan. The principal fishing grounds are the coasts of Siberia, Alaska and British Columbia and the high seas adjacent to Japan.

An annual average catch of the industrially important the genus *Oncorhynchus* during the 10 years from 1959 to 1968 was about 398 thousand tons. The largest catch was of pink salmon *Oncorhynchus gorbuscha* (Walbaum) 163 thousand tons, 40.8%, followed by chum salmon *Oncorhynchus keta* (Walbaum) (107 thousand tons, 26.8%), sockeye salmon *Oncorhynchus nerka* (Walbaum) (73 thousand tons, 18.3%) and silver salmon *Oncorhynchus kisutch* (Walbaum) (36 thousand tons, 8.9%) while and that of king salmon *Oncorhynchus tshawytscha* (Walbaum) (21 thousand tons, 5.2%) was smallest. (See Table I-1)

Among the genus *Oncorhynchus*, sockeye salmon is of the most excellent quality, and the canned product is highly prized as international merchandise. The fishermen in each of the named countries are interested in the production of the sockeye salmon.

The genus *Oncorhynchus*, of the family *Salmonidae*, has been studied in many countries from ancient times owing to the importance of the stock and its ecological characteristics. However, the studies were largely focused on the life of the

Table I-1. Commercial salmon catch by countries and by species, in thousand metric tons (round weight), average of 1959-1968.

Country \ Species	Sockeye	Chum	Pink	Coho	Chinook	Total	%
U.S.A.	35.6	22.0	50.9	12.6	12.4	133.2	33.4
Canada	10.7	8.5	22.5	12.4	6.1	60.2	15.1
Japan	22.4	45.8	59.1	6.8	1.1	135.2	34.0
U.S.S.R.	4.0	30.4	30.4	3.7	1.0	69.0	17.5
Total	72.7	106.7	162.6	35.5	20.6	398.1	100.0

fish in its fresh water stage, therefore very little was known about its life in its oceanic stage, especially in the open sea.

Under the circumstances the Biological Survey Committee, a Sub-committee of the International North Pacific Fisheries Committee (INPFC), has been investigating since 1952 the following four subjects in order to determine the justice of the tentative abstention line prescribed in the Japanese-American-Canadian Fishery Treaty:

- (1) Offshore distribution of salmon, (2) Identification of the stock,
- (3) Liberation of tagged fish, (4) Oceanic environment.

The Soviet-Japanese Fishery Committee has since 1956 endeavored to determine the stock variations in order to secure the preservation of the stock of salmon. Thus due to the results of the identification of local fish schools, the oceanic conditions, and offshore distribution of the salmon, which have been surveyed by many investigators of the four countries, the stocks of the genus *Oncorhynchus* and the life in the offshore stage are rapidly being made clear.

Oncorhynchus nerka (Sockeye salmon), as well as other *Oncorhynchus* species, hatch in fresh water and go down river into the sea for their nursery ground. After maturing the fish go up river to spawn and die after the spawning. The genus *Oncorhynchus* generally exhibit a homing habit, the fish go up the mother river (*Oncorhynchus gorbusha* returns to a river in the neighborhood of the hatching river). On the other hand, sockeye salmon use only mother-rivers with lakes upstream. It takes between 3 and 8 years to mature in the fresh water area or seas, generally 5 years. In general the fresh water stage is 1~2 years or 3~4 years, but rarely 5 years, and then the fish move in to the sea. The farther north the sockeye salmon live, the longer is their residence in fresh water.

Among the genus of *Oncorhynchus*, the sockeye salmon are thought to form local schools characteristically independent of each other, according to the geographical distance from mother-river, or differences in biological reproduction. Sockeye salmon have a strong homing habit, therefore it is believed that they form reproductive units based on native rivers.

Sockeye salmon caught by Japanese fishermen belong to Kamchatka west coast

Table I-2. *Catch of pacific salmon by Japanese fishery in thousand metric tons, 1952-1961. (Kasahara, 1963)*

Year	Sockeye	Chum	Pink	Coho	Chinook
1952	15.2	9.5	25.4	0.5	—
1953	3.8	17.5	21.3	0.7	—
1954	9.2	38.8	25.1	2.9	—
1955	25.7	61.7	75.2	9.1	—
1956	19.9	50.5	71.9	9.0	—
1957	42.6	44.6	96.0	9.3	—
1958	34.0	103.7	89.4	13.4	—
1959	26.2	79.7	100.3	8.3	—
1960	37.8	72.6	60.2	7.4	—
1961	37.8	53.4	74.7	5.8	—
mean	25.1	53.2	63.9	6.6	—
%	16.9	35.8	42.9	4.4	—

groups (Ozernaia River group and Yavina River group), Kamchatka east coast group (Kamchatka River group) and western Alaska group (Wood River, Nushagak R., Kvichak R., Naknek R., Egegik R. and Ugashik R. groups).

In the annual catch of the genus *Oncorhynchus* by Japanese fishermen sockeye salmon average 16.8% of the total (Table 1-2). The absolute weight of catch and relative weights between the genus of *Oncorhynchus* varies year by year.

In mother-boat salmon fishery, the main objective is sockeye salmon, but the weight caught fluctuates due to variations in the migration of the fish of each school, and is reflected in the economic value. The variation of weight of sockeye salmon caught in mother-boat fishery is influenced not only by the variation of the abundance of the migrant of the fish, but also mainly by the degree of success in catching American sockeye salmon. The only opportunity to fish American sockeye salmon is when the western Alaska sockeye salmon migrate westwards over the tentative abstention line (longitude 175°W, set by the Japanese-American and Canadian Fishery Treaty) into the fishing grounds of Japanese fishing boats.

As seen in 1957, 1961 and 1965, the matured western Alaska sockeye salmon migrated abundantly into the sea area south of the Aleutian Islands on the way to mother-rivers, and west of the tentative abstention line. This phenomenon of a wide migration over the limit line is rare. Generally, the matured western Alaska sockeye salmon migrate through channels between the Aleutian Islands located east of the line, and into the Bering Sea, and move eastwards into Bristol Bay, into which the mother-rivers flow. Thus it is scientifically and commercially important to clarify the mechanism of the homing migration of the western Alaska sockeye salmon.

Investigations of the homing migration of western Alaska sockeye salmon by the liberation of tagged fish have been carried out by Fukuhara et al. (1962), Hartt

Fig. I-1. Training Ship *OSHO RO MARU* Hokkaido University.

Table II-1. Commercial catch of salmon in Western Alaska in total number of fish and species percentage, 1951-1960. (Kasahara, 1963)

Year	Total number of fish (1000)	Percentage				
		Sockeye	Pink	Chum	Coho	Chinook
1951	5,350	87.8	0.4	8.5	1.4	1.9
1952	12,395	96.1	0.4	4.2	0.6	0.7
1953	7,493	88.5	1.1	8.2	0.4	1.4
1954	6,709	74.7	11.3	12.2	0.9	1.9
1955	5,685	90.5	0.5	6.0	0.5	2.3
1956	11,357	90.2	1.1	6.9	0.5	1.2
1957	7,428	89.2	+	7.4	1.2	2.1
1958	6,257	55.2	28.9	9.8	3.1	2.9
1959	6,428	81.6	0.3	13.8	1.2	3.0
1960	17,377	82.9	4.5	11.1	0.3	1.1
	\bar{x} 8,674.9	83.6	4.8	8.8	1.0	1.8

(1962, 1966), Favorite and Hanavan (1963), Kondo et al. (1965), Manzer et al. (1965), Margolis et al. (1966), Taguchi (1966), Hanamura (1967). The conditions under which the sockeye salmon pass through the channels between the Aleutian Islands and the relation between the oceanographic conditions and the behavior of the fish after entering into the Bering Sea were also investigated by Hanavan et al. (1959), Johnsen (1964), Landrum and Dark (1968) and Dunn (1969), but only on a limited scale, and the whole aspect is not yet known.

The author, in his capacity as captain of the *Oshoro Maru*, a training ship of Hokkaido University, has been in a position to carry out since 1955 exploratory fishing by gill net and concurrent oceanographic investigations. Since 1962, he has

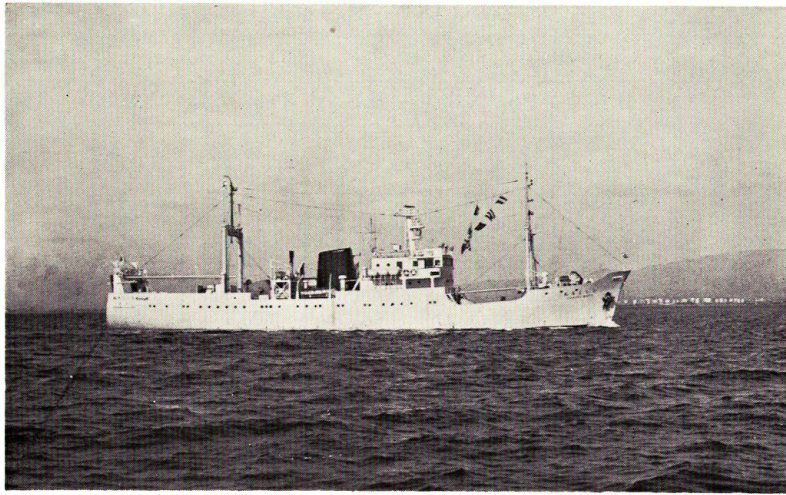
Table II-2. *The annual-weekly catches of sockeye salmon*

		1962		1963		1964	
		B.B.	Pen. N.S.	B.B.	Pen. N.S.	B.B.	Pen. N.S.
JUNE	WEEK 1	+	+	-	0.1	0.2	0.2
	2	0.1	0.2	0.7	0.7	0.6	1.1
	3	3.8	5.3	1.9	2.4	30.4	7.1
	4	98.2	20.3	149.8	14.1	455.1	20.8
	5	771.1	43.9	346.4	26.7		
JULY	WEEK 1	2218.4	68.1	1260.1	78.3	1495.1	36.6
	2	1362.5	53.1	743.7	26.2	2807.4	48.8
	3	218.6	20.6	266.9	14.9	570.6	37.3
	4	34.5	14.6	74.7	28.0	164.9	17.9
	5						
AUGUST	WEEK 1	9.0	10.7	18.3	15.4	52.9	21.3
	2	1.3	11.2	5.1	12.0	10.5	29.7
	3	0.6	7.2	3.2	5.1	2.6	10.7
	4	+	0.6	0.4	1.2	0.7	2.6
	5			+	0.2	-	0.6
SEPTEMBER	WEEK 1	-	+	-		-	0.1
	2	+	+			-	+
	3	+	+				
	4	+	-				
	5						
TOTAL		4718.0	256.2	2871.2	225.2	5591.0	234.5

B.B. . . . Bristol Bay Pen.N.S. . . . Peninsula North Side

conducted investigations with the *Oshoro Maru* on the distribution and migration routes of the western Alaska sockeye salmon in the eastern part of the Bering Sea, where these fish are abundant.

This paper discusses the passage of the western Alaska sockeye salmon from the sea south of the Aleutian Islands into the Bering Sea, and the migration routes off Bristol Bay.

II. Review of Studies on the Western Alaska Sockeye Salmon and on the Oceanographic Structure of the Sea in Which the Fish Migrate

The genus *Oncorhynchus* in the western Alaska sea area is fished mainly along the coasts of Bristol Bay, excluding king salmon and silver salmon which are fished in small quantities in northwestern Alaska. In Bristol Bay sockeye salmon is fished most abundantly (Margolis et al., 1966).

Bristol Bay is the best fishing ground of sockeye salmon in the world, and it has been explored since 1884 (Cobb, 1930). Sockeye salmon constitute more than 80% of the genus *Oncorhynchus* migrating into the Bay (Table II-1). Sockeye salmon migrating to spawn in mother-rivers which flow into the Bay (Wood R., Nushagak

in the Bristol Bay District. (INPFC, 1962-1967)

1965		1966		1967	
B.B.	Pen. N.S.	B.B.	Pen. N.S.	B.B.	Pen. N.S.
2.2	+			0.1	+
1.7	0.5	+	0.3	1.5	0.1
21.9	4.3	4.5	1.9	13.4	0.1
2210.3	11.3	303.4	9.6	579.7	7.9
7950.7	13.8	2597.5	19.9	2170.0	36.0
7790.1	56.1	5295.8	67.9	984.6	42.6
5845.7	38.9	920.3	28.9	360.3	39.5
760.1	16.9	155.6	32.0	176.4	36.2
33.8	25.5	24.4	31.2	30.6	29.7
2.4	14.2	10.7	28.3	8.9	18.2
0.3	10.4	1.8	10.5	1.8	9.2
+	4.6	0.1	3.0	0.2	5.0
+	0.5	+	0.2	0.1	0.1
+	2.7	+	1.4	-	0.1
-	0.1	-	0.2	+	0.1
		+	-	+	+
24519.3	199.5	9314.2	245.3	4330.7	224.7

R., Kvichak R., Naknek R., Egegik R., Ugashik R. etc.) are mostly fished from June to September every year with the height of fishing season being early and middle July (Table II-2).

Rich and Ball (1928) divided the sockeye salmon in the Bay into two schools, Nushagak school and a school composed of Kvichak-Egegik-Ugashik salmon, based on the difference in fishing conditions and on differences in age composition. Hanamura (1967) subdivided the sockeye salmon into a rapid growth group and a slow growth group because the age composition varies according to growth rate in the same local school.

The vertical distribution of the genus *Oncorhynchus* in offshore areas shows that 90% of the catch is obtained between 0 and 5 m depth at night and a decreasing catch in the 0~15 m depth layer in the day in the northwestern Pacific Ocean (Machidori, 1966, 1967, 1968).

In the Gulf of Alaska, sockeye and chum salmon are observed to live down to about 61 m depth (Neave, 1960). It is presumed that there is difference in vertical range between Asian and American waters, the cause of which is thought to be differing vertical distributions of water temperature in the fishing grounds.

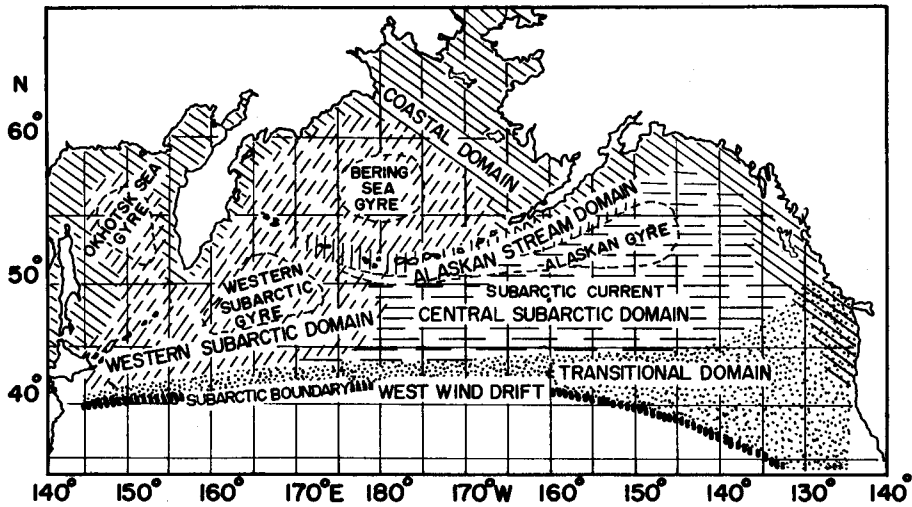

Fig. II-1. Schematic diagram of upper zone domains. (Dodimead et al., 1963)

In Asian areas there exists a dichothermal layer, in which the water temperature below 10 m depth falls suddenly; on the other hand, in the Gulf of Alaska there is no rapid decrease in temperature even as deep as 100 m (Taguchi, 1966).

Favorite and Hanaban (1963) deduced that the distribution of the genus *Oncorhynchus* in the oceans is limited to subarctic cold waters and that there is some relation to marine environmental conditions, based on the studies of Watanabe (1954), Taguchi (1957a), Hanavan and Tanonaka (1959) and Maeda (1959).

Konda (1959) suggested that the polar front at longitude 175°E in the middle Pacific Ocean moves northwards between 120 and 180 miles from spring to summer, and that this has something to do with the migration of the genus *Oncorhynchus*.

The Biological Survey Subcommittee in INPFC has pointed to the importance of the interpretation of the marine environmental conditions in relation to the distribution of Asian or American schools of *Oncorhynchus* and their migration routes. In concert with this suggestion oceanographical reports have been offered by many investigators in each country.

From data and reports of many investigations in the northern Pacific Ocean, Dodimead et al. (1963) divided the North Pacific Ocean into Subarctic, Transitional and Subtropical waters based on differences of salinity. They described the characteristics of water temperature and salinity which distinguish each water mass. The main characteristic of Subarctic waters is the salinity stratification, which is caused by environmental change in the waters owing to time and space. They used the term "domain" in place of "water mass" to distinguish regions with similar structure and oceanographic behavior. They then described identifying

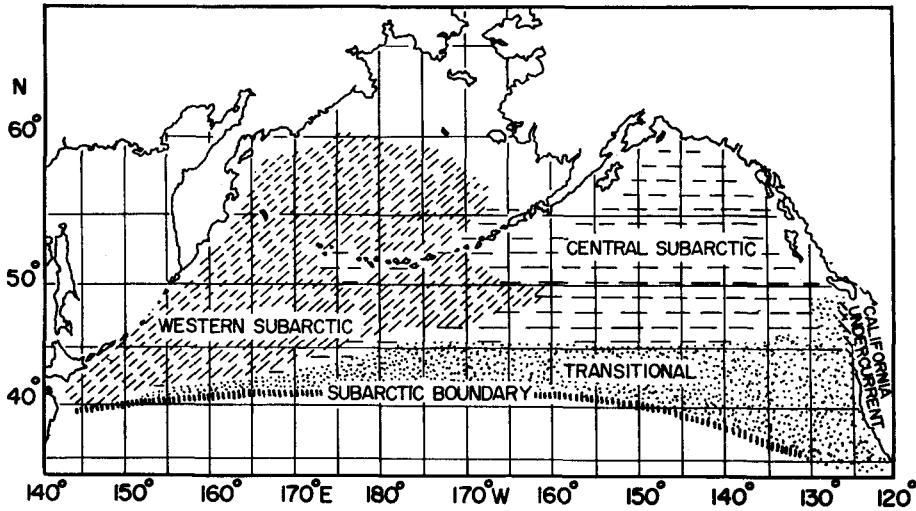

Fig. II-2. Schematic diagram of lower zone domains. (Dodimead et al., 1963)

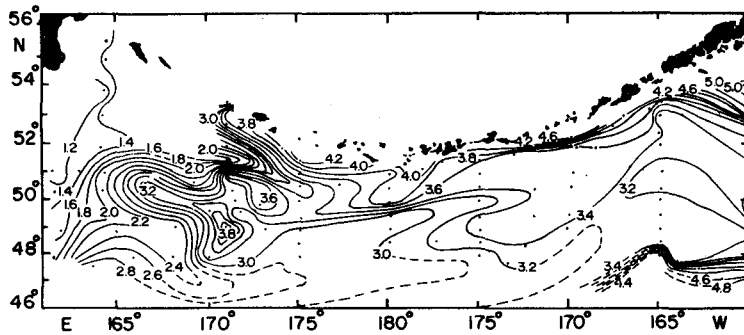

Fig. II-3. Distribution of temperature (°C) in the temperature-minimum stratum, summer 1959. (Favorite, 1967)

characteristics obtaining in the upper and lower layers of each domain.

As the characteristics of waters in the upper layer are predominantly influenced by seasonal heating or cooling, rainfall, evaporation and wind, the following five characteristic domains were distinguished (Fig. II-1): (1) Western subarctic domain, (2) Transitional domain, (3) Alaskan stream domain, (4) Central subarctic domain, (5) Coastal domain.

The characteristics of waters in the lower layer are condition by internal advection and mixing of the waters, and in the lower layer they identified: (1) Western subarctic domain, (2) Transitional domain, (3) Central subarctic domain, (4) California undercurrent domain (Fig. II-2).

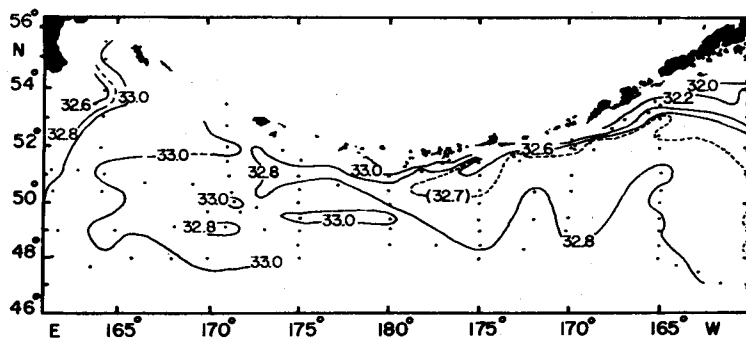

Fig. II-4. Distribution of surface salinity (‰), summer 1959. (Favorite, 1967)

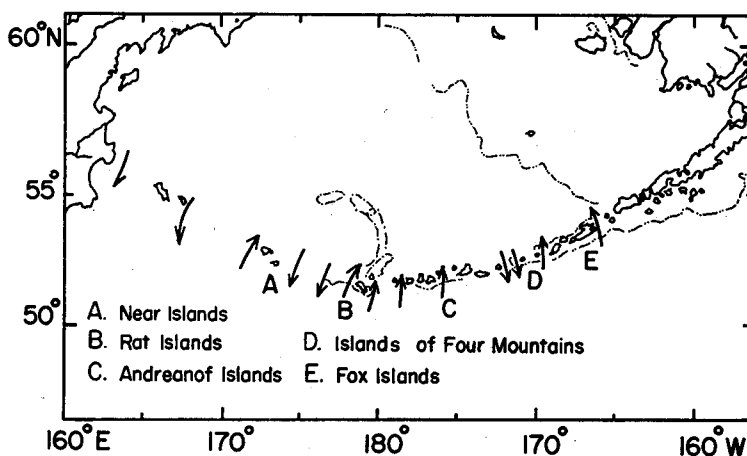

Fig. II-5. Schematic diagram of northward and southward streams through the passes of the Aleutian Islands.

They said that the distribution of the genus *Oncorhynchus* should bear some relation with these domains.

The Alaskan Stream flows westward along the south side of the Aleutian Islands. In the area south of and close to the Islands, a higher temperature zone extends east and west with higher values to the east and lower to the west (Fig. II-3). The surface distribution of salinity shows a minimum south of the Islands, and the low salinity water extends east and west with higher values to the west and lower to the east (Fig. II-4).

The Alaskan Stream is considered to be caused predominantly by the wind regime in the northeastern Pacific Ocean. It is a stream of coastal water moving westwards with high temperature and relatively low salinity, flowing from the Gulf of Alaska (Favorite, 1967).

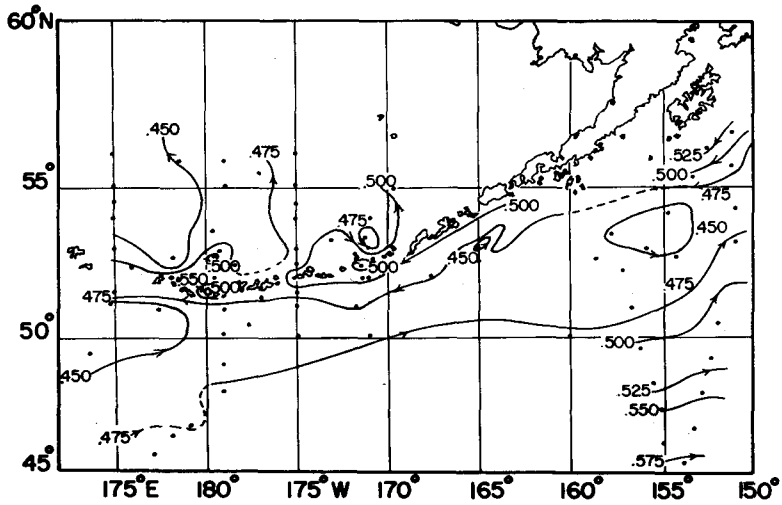

Fig. II-6. Anomaly of geopotential topography, 0/300 db. (Callaway, 1963)

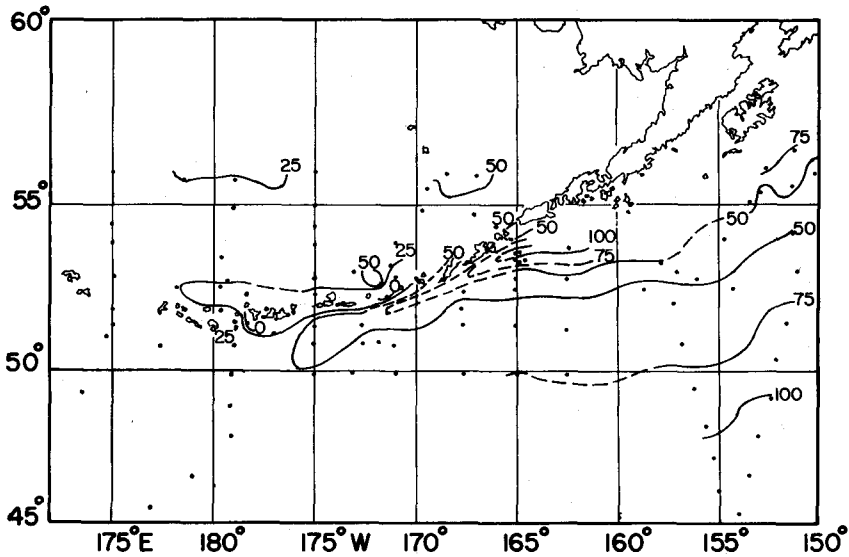

Fig. II-7. Depth (meters) of the 26.0 sigma-t surface. (Callaway, 1963)

According to the U.S. sailing directions (U.S.C.G.S. 1955), tidal currents are complex in this area, and it is said that there are strong currents in channels between the Islands. The presence of northward currents through the channels has been known since early times (Ratmanoff, 1937, Barnes and Thompson 1938).

It is also clear that a part of the Alaskan Stream flowing westward along the

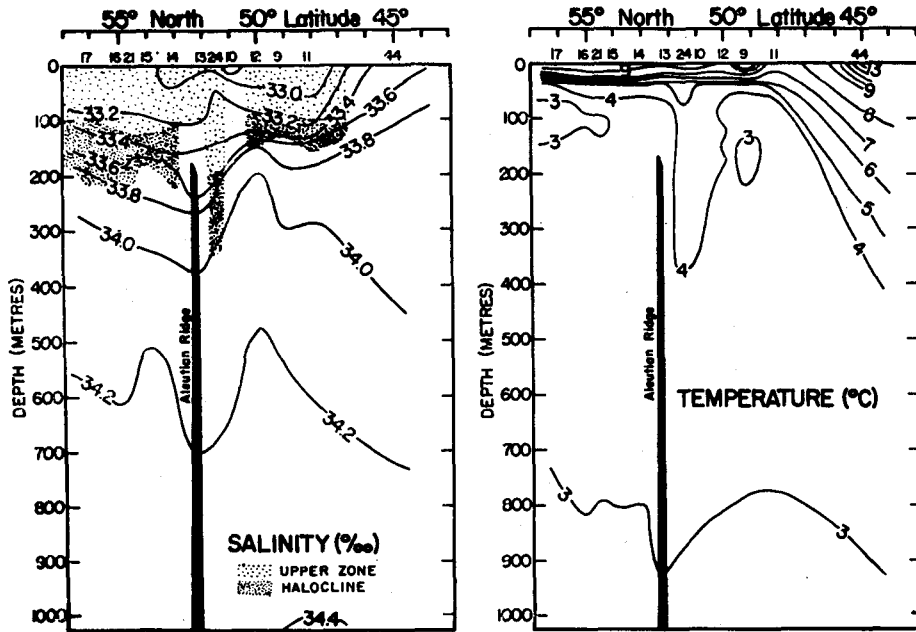

Fig. II-8-A. Vertical section of salinity and temperature along long. 175°E, summer, 1957. (Dodimead et al., 1963)

south side of the Aleutian Islands passes into the Bering Sea through some channels and then flows eastwards along the north side of the Islands (Mishima and Nishizawa 1955).

Dobrovolskii and Arsenev (1959) divided the main routes of the currents flowing from the Pacific Ocean into the Bering Sea into three categories:

- (1) Eastern part of Near Strait;
- (2) Eastern part of the Four Mountains Islands, and almost all channels in the Fox Islands area; and
- (3) Passes between the Rat Islands and Andreanof Islands (Amchitka and Tanaga Passes).

Some main routes for currents flowing oppositely from the Bering Sea into the Pacific Ocean are (Fig. II-5):

- (1) Passes near the Rat Islands and their western part;
- (2) Western part of Near Strait;
- (3) Western part of Kamtchatka Strait; and
- (4) Amkuta Pass and passes among the Four Mountains Islands.

Callaway (1963) also defined the routes and directions of flow through the Passes based on dynamic calculations and the depth of the $\sigma_t=26.0$ density surface (Fig. II-6, -7).

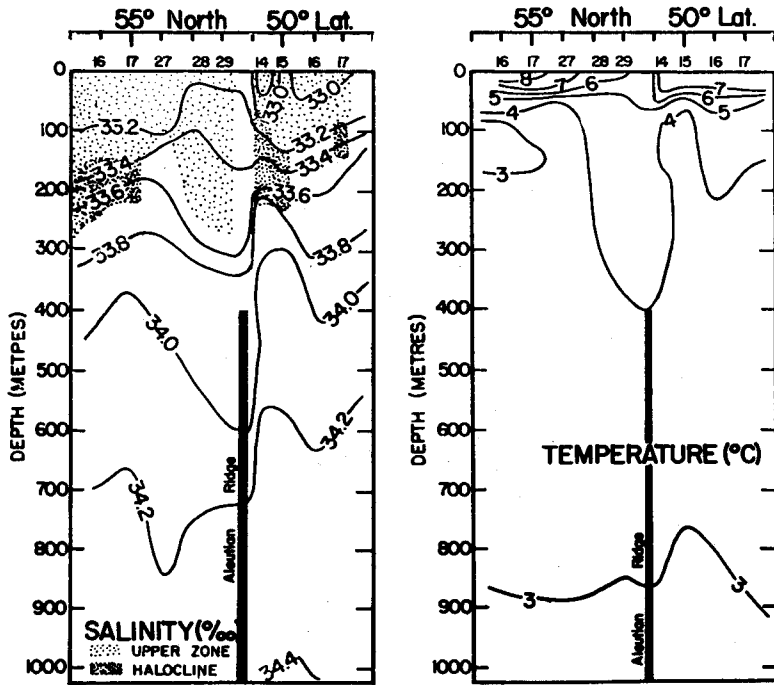

Fig. II-8-B. Vertical section of salinity and temperature along long. 180°, summer, 1957. (Dodimead et al., 1963)

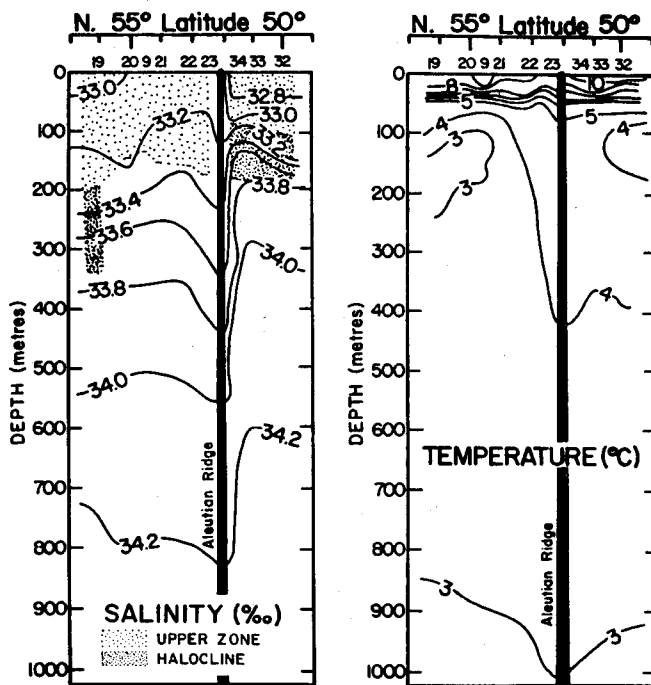

Fig. II-8-C. Vertical section of salinity and temperature along long. 175°W, summer, 1957. (Dodimead et al., 1963)

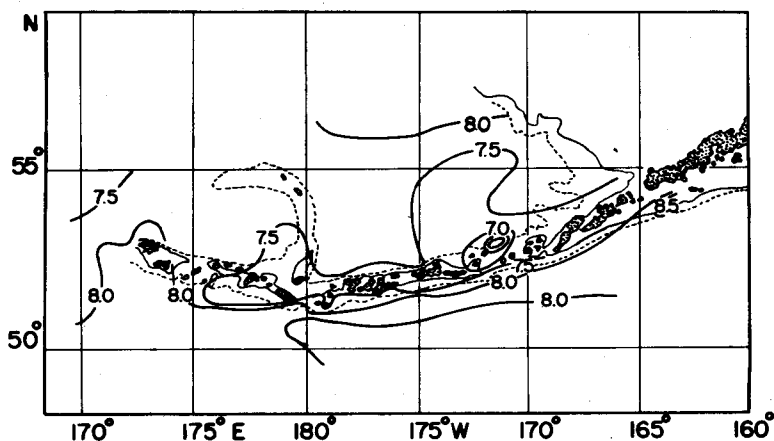

Fig. II-9. Distribution of temperature ($^{\circ}\text{C}$) at 10 meters near the Aleutian Islands. (Dodimead, 1958)

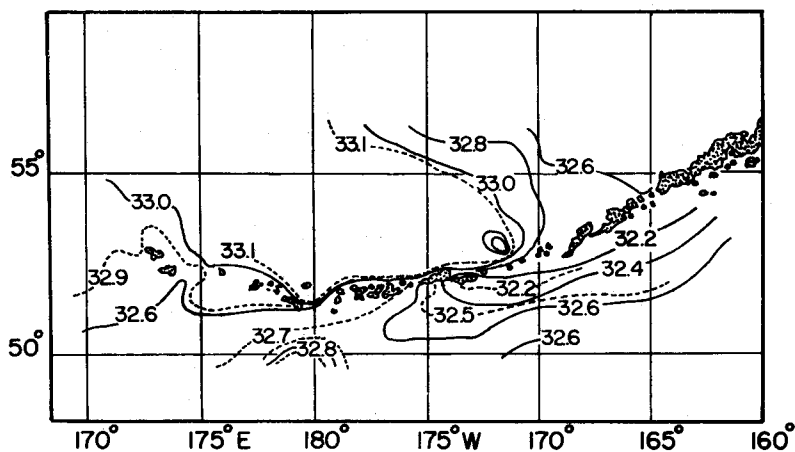

Fig. II-10. Distribution of salinity (‰) at 10 meters near the Aleutian Islands. (Dodimead, 1958)

As seen in Fig. II-8, a vertical section from south to north across the Aleutian Islands, a comparatively sharp halocline is characteristically present in the 75 ~ 150 m depth layer, the isohalines in the lower layer assume a dome-like shape south of the Islands, and the oceanographic strata in shallow channels are destroyed by vertical mixing (Callaway, 1963, Dodimead et al., 1963). This is caused by upwelling, and tidal currents around the channels and islands (Callaway, 1963). Dodimead (1958) observed that the temperature is lower and the salinity higher in the Bering Sea north of the Aleutian Islands than in the northern Pacific Ocean (Alaskan stream domain) which lies south of the Islands (Figs. II-9, -10).

There have been fewer oceanographic studies in the Bering Sea than in the

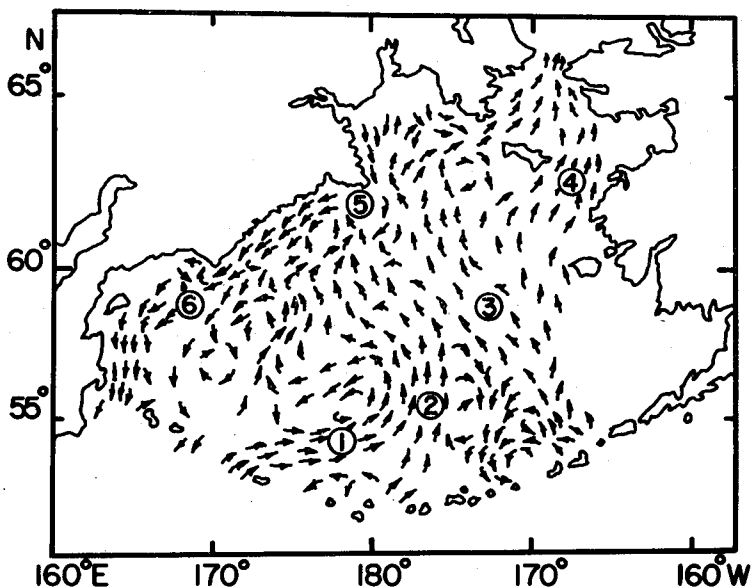

Fig. II-11. Surface circulation in the Bering Sea. (Dobrovolskii and Arsenev 1959)
 1. Attu current 2. Tanaga current 3. Transverse current 4. St. Lawrence current
 5. Anadyr current 6. Kamchatka current

northern Pacific Ocean area. The general characteristics of the western subarctic domain including the Bering Sea area are as follows: (1) There always appears a cold minimum temperature subsurface at a lower part of the upper layer (this layer is called the dichothermal layer); (2) the depth of the upper layer is between 100 and 150 meters; (3) relatively high salinity water prevails, generally between 33.0 and 33.2‰, in the surface of the Bering Sea; (4) in the center of the sea a current eddy exists (Dodimead et al., 1963).

Dobrovolskii and Arsenev (1959) found several current eddies in the surfac circulation of the Bering Sea: (1) A part of Attu-Tanaga current which flows northeastwards or northwards from several channels of the western Aleutian Islands, from Near Islands to Andreanof Islands, turns westwards at near 56°N, 180°; (2) A part of the Transverse current, which flows northwards over the continental shelf and along the continental slope from several channels between the Fox Islands and from close to the end of the Alaska Peninsula, turns west at 56°N. There is also a clockwise current eddy between the later current and the Tanaga current (Fig. II-11). Saur et al. (1952) also observed a westward current in the upper layer which reaches to 178°W at near 56°N in the eastern Bering Sea, based on dynamic calculations (Fig. II-12). Dodimead (1958) also observed that the Alaskan Stream enters the Bering Sea, flows eastwards along the north side of the Aleutian Islands,

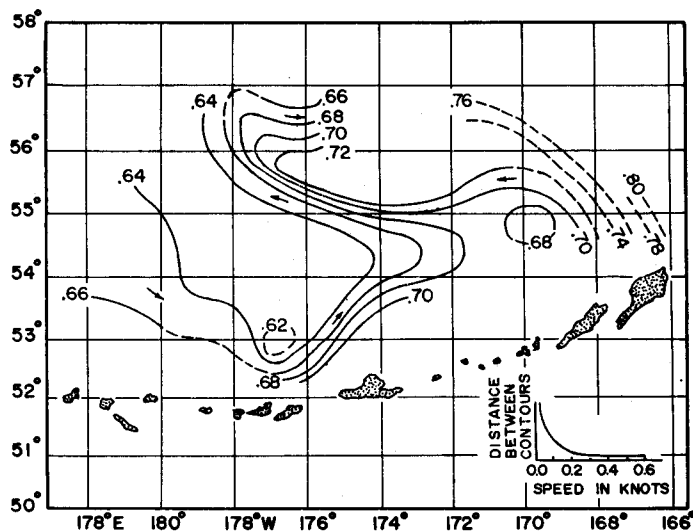

Fig. II-12. Dynamic height anomaly, 0/500 db. Bering Sea, July-August 1949. (Saur et al., 1952)

then flows northwestwards along the continental slope, and turns westward at near 56° – 57° N. He said this is perhaps owing to the topography of the sea bottom.

According to the U.S. Pilot chart (Fig. II-13), ice covers all the northern sea area in winter (January to February) except two regions: north of 57° – 58° N of the deep basin along longitude 180° ; and south of the Pribilof Islands (55° – 56° N) from the Unimak Island in the eastern continental shelf sea area to west of 162° W. In February the ice zone reaches its maximum extent of the year, and surface water temperatures reach their lowest values at the end of the cooling period of late winter (February to March) (Dodimead et al., 1963).

Bertha Ann, a U.S. exploratory vessel investigating the distribution of salmon in February of 1963 on longitude 175° E in the western Bering Sea, met with sea ice and therefore could not proceed north of $57^{\circ}28'$ N. The surface water temperature was 2.4° C at that time (French et al., 1964). *G.B. Kelez*, another U.S. exploratory vessel, also observed 1.0° C surface water temperatures at $56^{\circ}00'$ N– $176^{\circ}26'$ E and $57^{\circ}00'$ N– $175^{\circ}00'$ E (French, 1965).

Bristol Bay is situated at the southeast end of the shallow continental shelf area of the Bering Sea east of the line connecting Cape Sarichef (northwest end of Unimak Island) with the Kuskokwim River. It is separated from the north Pacific Ocean by the Alaska Peninsula. The movement of water in the Bay is influenced by runoff, sea ice, prevailing winds, tidal currents and oceanic conditions offshore. From spring to early summer strong southerly winds blow. According to drift bottle studies, water flows into Bristol Bay from the western

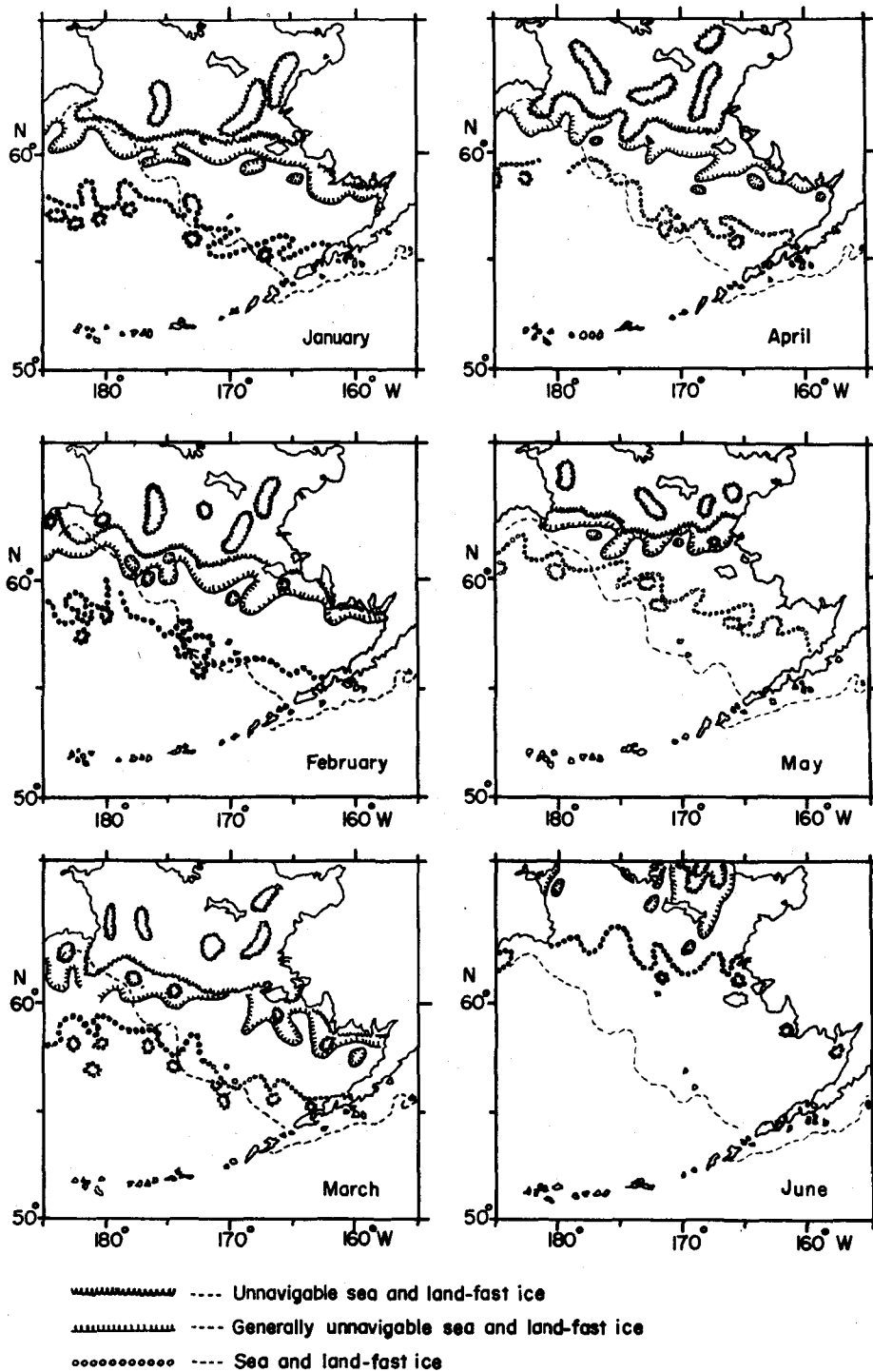

Fig. II-13. Ice regime in the eastern Bering Sea. (U.S. Pilot Chart)

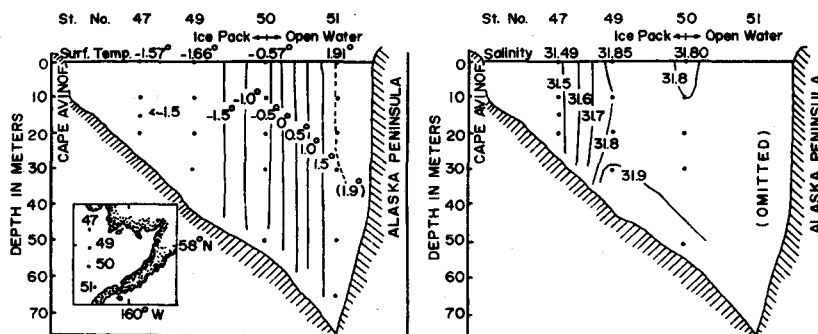

Fig. II-14. Vertical sections of temperature ($^{\circ}\text{C}$) and salinity (‰) at the mouth of the Bristol Bay in winter, 1955. (U.S. Navy Hydrographic Office, 1958)

extreme of the Aleutian Islands, from the Gulf of Alaska, and from as far south as latitude 45°N in the central subarctic domain (Dodimead et al., 1963). An anticlockwise tidal current is known in the Bay (Hebard, 1959). When the sea freezes in winter over the areas surrounding Bristol Bay the salinity difference between upper and lower layers is slight, therefore the vertical distribution of temperature and salinity are nearly homogeneous (Fig. II-14). The ranges of temperature and salinity are known to be -0.5° to $+1.5^{\circ}\text{C}$ and 31.5 to 31.8 ‰ , respectively (U.S.N.H.O., 1958).

Ohtani (1969) observed that there is formed a remarkably sharp thermocline at 15~25 m depth on the continental shelf in summer, the deeper layer remaining below 0°C . In cooling periods upper layer water becomes denser causing convection which can deepen the mixed layer, as can disturbance by strong winds. Furthermore, he observed that when the density of water below the halocline is too great convective mixing cannot be created in the lower layer.

From fishing experiments and the mother-boat fishery records, as shown in Fig. II-15, Manzer et al. (1965) reported that the southern limit in May, of the distribution of sockeye salmon is observed to be the polar front that is, the line connecting a point between 42°N and 45°N in the western Pacific Ocean with a point between 47°N and 49°N in the eastern Pacific Ocean. They reported also that in the area north of the line the maximum distribution density in May was observed from the south side of the Aleutian Islands to south of the Alaska Peninsula and offshore of the Gulf of Alaska. The distribution of sockeye salmon in June is wider than in May when they appear over the whole Bering Sea, and some groups appear in the Sea of Okhotsk and in the north Pacific Ocean southwest of Kamchatka Peninsula. In July and August the maximum distribution density lies to the west in contrast with June when maximum densities are found to the east.

From the results of fish tagging programs and experimental fishing by purse seine and scale test, Hartt (1962, 1966) suggested that the direction of movement of sockeye salmon in the Aleutian Islands area is as shown in Figs. II-16, 17, 18. He also noted that early in the fishing season the concentration of the genus *Oncorhynchus* is dense south of the Islands but thin to the north. He also ascertained that sockeye salmon migrate northwards through some channels, though only a few sockeye salmon were observed moving northwards through channels or on the north side, in spite of comparatively good catches south of the Aleutian Islands during the same fishing period. These observations suggest that the distribution of school of Kamchatka or western Alaska sockeye salmon can differ locally due to different oceanographic environments.

Fukuhara et al. (1962) and Landrum and Dark (1968) suggested an offshore distribution of western Alaska sockeye salmon based on morphological studies (Fig. II-19). Margolis et al. (1966) analyzed the distribution of sockeye salmon having different hatching areas, and suggested the ranges of the offshore distribution of Kamchatkan, western Alaskan and North American matured sockeye salmon, taking into account the results from liberation of tagged fish, morphological studies and scale tests (Fig. II-20). According to their results, the northern limit of the distribution of western Alaska sockeye salmon in the Bering Sea is a line connecting 174°W-58°N, 180°-57°N, 176°E-58°N, 173°E-57°N and 171°E-55°N.

In Figs. II-18 ~20 the range of each school of sockeye salmon is indicated, and from spring to summer each main school is observed to move northward along

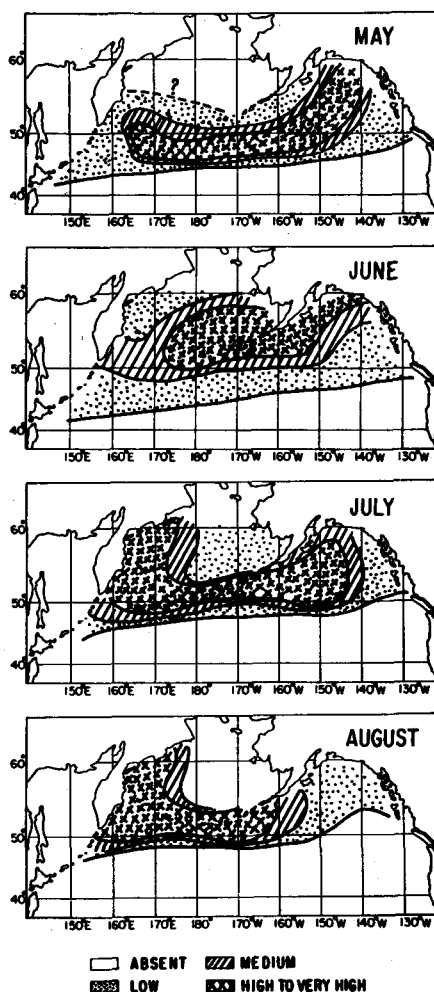

Fig. II-15. Schematic diagram showing distribution and relative abundance of sockeye salmon, May through August, mature and immature fish combined. (Manzer et al., 1965)

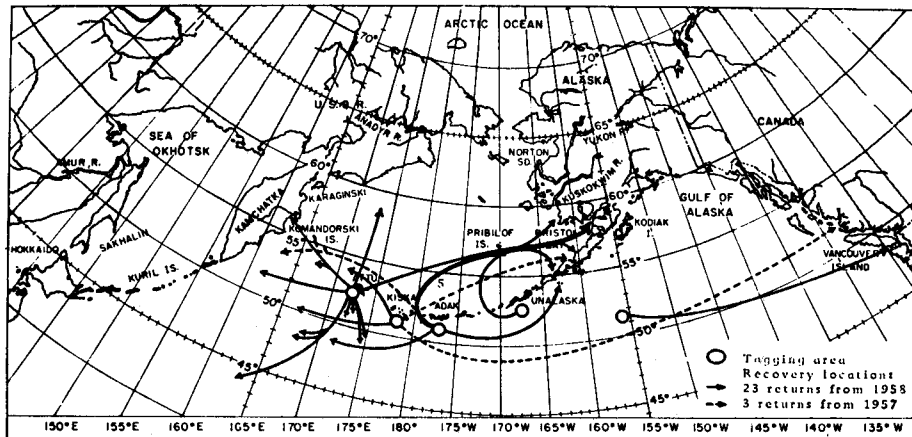

Fig. II-16. Recovery distribution of sockeye salmon tagged in 1957 through 1959. (all areas) (Hartt, 1966)

the western Alaska and Kamchatka coasts from the north Pacific Ocean.

The ranges of distribution of Kamchatka and western Alaska sockeye salmon, identified by recatching of the tagged fish, parasitological and morphological studies and scale tests, do not necessarily agree. The range ascertained by scale tests is wider than that determined from the former three experiments. There is some overlap of ranges between schools of sockeye salmon.

Birman (1967a, 1967b) reported that in the sockeye salmon which have lived in the coldest sea area ($1.5 \sim 6.0^{\circ}\text{C}$) during wintering the genital glands mature early, and that they shift from feeding migration to spawning migration and come inland to spawn early in June (these are called spring sockeye salmon), suggesting that some of their wintering areas are closer to the anadromous rivers than are those from schools which are late in maturing (called summer sockeye salmon).

French and Mason (1964) and French (1965) reported sighting a school of sockeye salmon in the Bering Sea in winter.

As to the distribution of *Oncorhynchus* in the northern North Pacific Ocean, it has been suggested that there might be some relationship with the oceanographic domains and the ocean currents which would influence their distribution (Favorite et al. 1963, Taguchi, 1966). Western Alaska sockeye salmon might accommodate themselves to the environment because of certain physiological and ecological factors in the distribution area. The main oceanic domains are central Subarctic, Alaskan Stream, western Subarctic and eastern coastal domain of the Bering Sea.

III. Surveying Methods and Data

The *Oshoro Maru* has conducted oceanographic observations together with

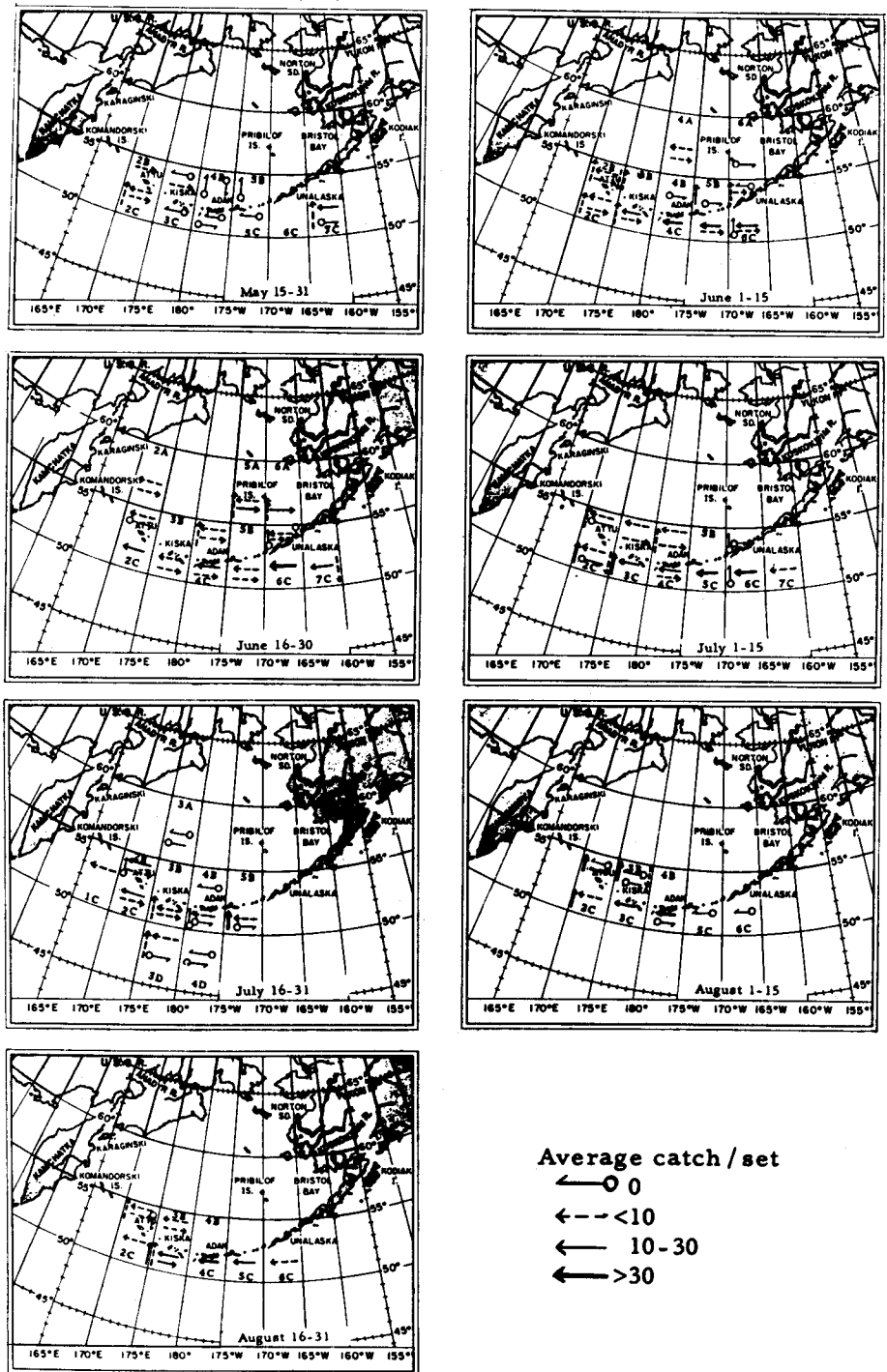

Fig. II-17. Direction of movement of sockeye salmon in the Aleutian Islands area, as determined from purse-seine catches. (Average catch per set by area and by two week periods, 1956 to 1958 combined) (Hartt, 1962)

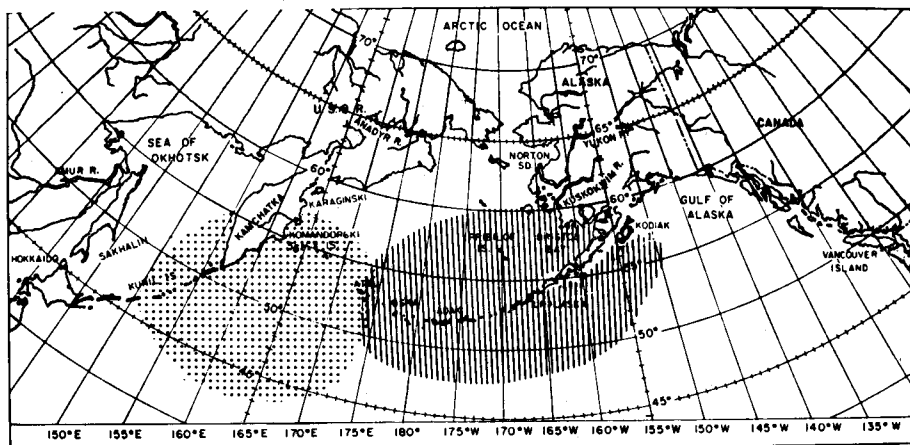

Fig. II-18. General oceanic distribution of Kamchatka vs. western Alaska sockeye salmon as shown by coastal tag returns through 1960. (Hartt, 1966)

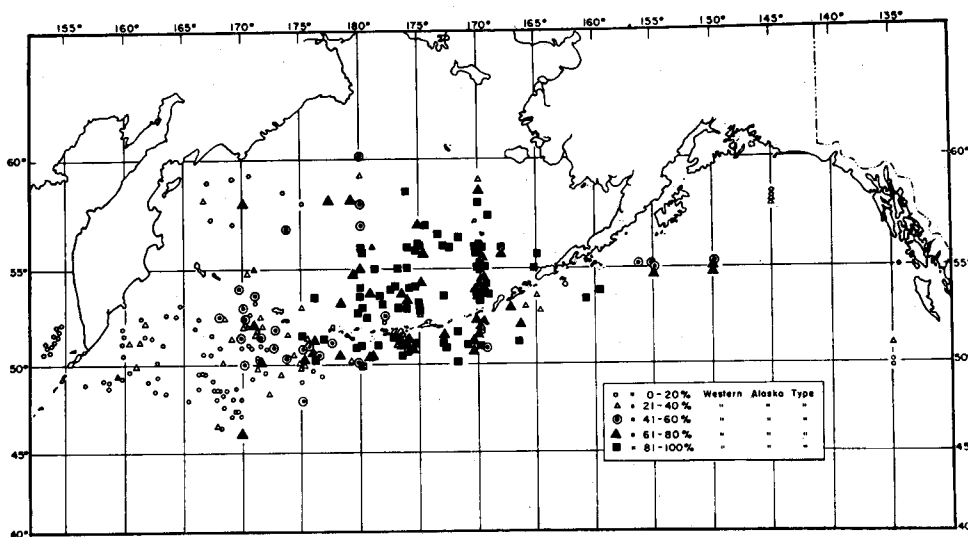

Fig. II-19. Summary of the high sea distribution of mature western Alaska sockeye salmon, 1956-1962, samples. (Landrum and Dark, 1968)

exploratory fishing by gillnet in June and July every year from 1962 through 1968.

III-1. Data Obtained

III-1-1. Data of Oceanographic Observations

The properties measured were water temperature and salinity. The detailed

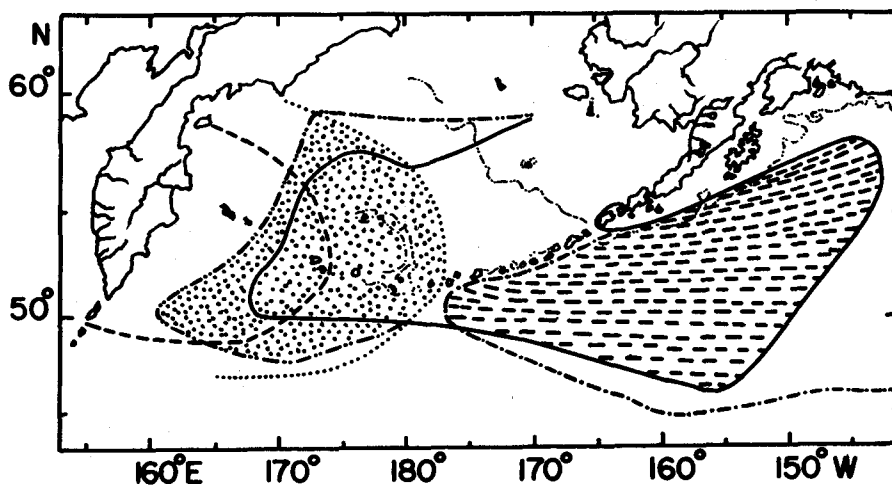

Fig. II-20. Range of Kamchatka, western Alaska and other North American stocks of mature sockeye salmon, and areas of overlap. (Margolis et al., 1966)

- Delimits the area occupied by maturing western Alaska sockeye as determined by coastal tag returns and by parasites
- - - Possible extension of area occupied by maturing western Alaska sockeye as determined by morphological and scale studies
- Limits of area occupied by maturing Kamchatkan sockeye as determined by coastal tag returns and by parasites
- Possible extension of area occupied by maturing Kamchatka sockeye as determined by high sea tag returns and morphological and scale studies
- - - Limits of known area occupied by maturing sockeye from other north American stocks
- Area of overlap of mature western Alaskan sockeye salmon and Kamchatkan sockeye salmon
- Area of overlap of mature western Alaska sockeye salmon and American sockeye salmon

Table III-1. Marine research in the northern North Pacific Ocean and the Bering Sea by the Oshoro Maru, 1962-1968.

Year	Marine observations		Items of research	Data Rec. Oceanogr. Obs. Expl. Fish. (Hokkaido Univ.)
	No. of station	Dates		
1962	62	May 23-June 29	Temperature, salinity	No. 7 1963 p. 46~ 77
1963	97	May 24-July 16	"	No. 8 1964 p. 208~256
1964	127	June 6-Aug. 15	"	No. 9 1965 p. 230~277
1965	114	May 31-Aug. 2	"	No. 10 1966 p. 260~299
1966	81	June 13-Aug. 2	"	No. 11 1967 p. 174~200
1967	97	June 9-Aug. 20	Temperature, salinity, Dissolved oxygen, reactive phosphorus,	No. 12 1968 p. 297~343
1968	83	June 10-Aug. 11	Temperature, salinity, dissolved oxygen, phosphate, Phosphorus, nitrate	No. 13 1969 p. 7~ 40

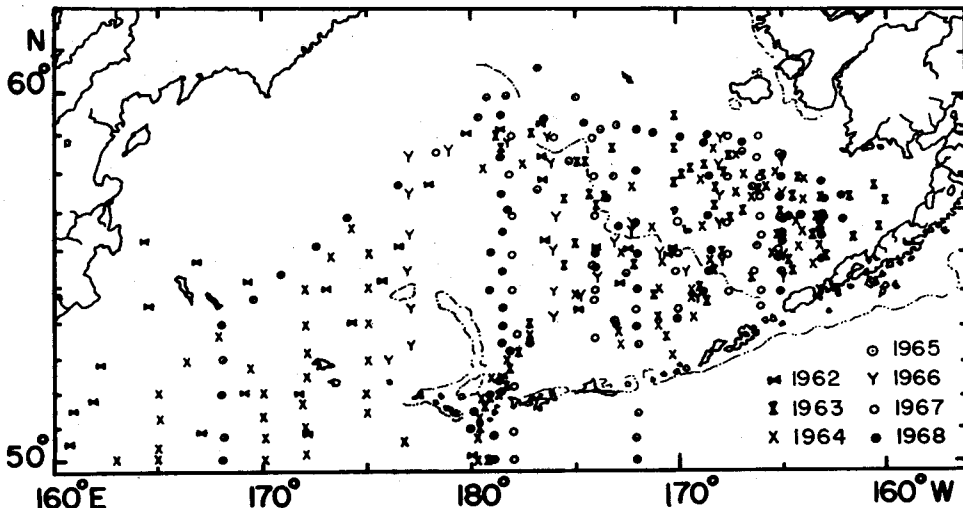

Fig. III-1. Distribution of stations occupied from June to July in each year, 1962-1968 from the *Oshoro Maru*.

Table III-2. *Salmon gillnet research in the northern North Pacific Ocean and the Bering Sea from the Oshoro Maru, 1962-1968.*

Year	Number of gillnet sets	Dates	Total number of gillnets used	Catch, number of fish			
				Sockeye	Chum	Pink	other
1962	16	May 28-June 27	1325	555	1441	1097	13
1963	14	June 13-July 16	1623	1791	905	1238	41
1964	25	June 7-Aug. 14	2808	3556	5022	448	89
1965	22	June 2-July 29	2285	10652	1908	389	43
1966	31	June 13-July 30	3251	8104	4501	552	319
1967	21	June 12-Aug. 14	2234	5712	1915	740	174
1968	22	June 10-Aug. 11	3045	5510	3374	723	357

data have been reported in "Data Record of Oceanographic Observations and Exploratory Fishing, Faculty of Fisheries, Hokkaido University", Nos. 7~13.

The oceanographic stations and the observation period in each year are reported in Table III-1 and Fig. III-1. The oceanographic observations were mainly carried out in the upper layer, the swimming layer of *Oncorhynchus*.

Oceanographically the region was divided into four areas based on the topography:

1. The Aleutian Islands Passes, west of the Near Islands to longitude 173°E and east of the same Islands to longitude 175°E. Amchitka and Tanaga Passes;
2. The portion of the Bering Sea basin south of latitude 60°N and east of longitude 175°E;
3. The continental slope area in the eastern part of the Bering Sea, from north of

Table III-2. *Continued.*

Items of Research	Data Rec. Oceanogr. Obs. Expl. Fish. (Hokkaido Univ.)
Catch of salmon by gill nets, biological characteristics of salmon caught	No. 7 1963 p.111~138
	No. 8 1964 p.261~286
	No. 9 1965 p.286~306
Catch of salmon by gill nets, biological characteristics of salmon caught, stomach contents of salmon	No. 10 1966 p.320~327
	No. 11 1967 p.226~252
Catch of salmon by gill nets, biological characteristics of salmon caught	No. 12 1968 p.344~367
	No. 13 1969 p. 76~118

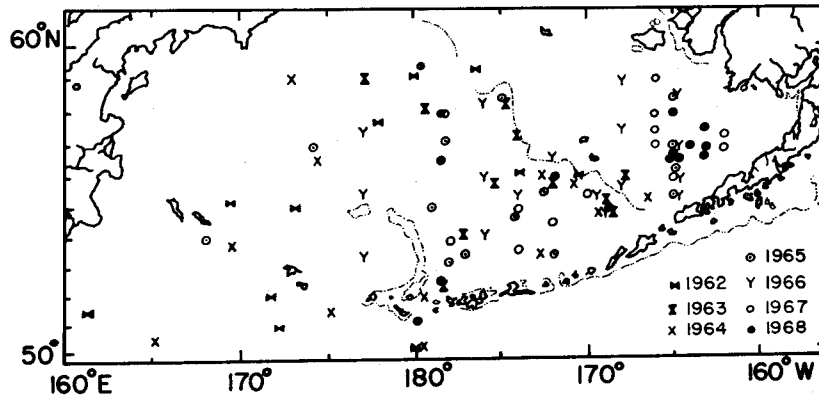
Fig. III-2. Exploratory fishing stations with gillnets from June to July in each year, 1962-1968 from the *Oshoro maru*.

- the Unimak Island northwestwards to 60°N; and
4. The eastern continental shelf area including Bristol Bay located east of longitude 180°, west of 161°W, and south of latitude 64°N.

III-1-2. Data on the Distribution of the Genus *Oncorhynchus* and the Biological Statistics

The number of shackles of gillnets by mesh size and the number of each kind of *Oncorhynchus* classified at each observing station were reported in "Data Record of Oceanographic Observation and Exploratory Fishing, Faculty of Fisheries, Hokkaido University", Nos. 7~13.

Data on the number of gillnet sets and kinds of fish caught are reported in Table III-2. The gillnet exploratory fishing stations from June to July in each year are shown in Fig. III-2.

Table III-3. *Description of the gillnets employed in the fishing experiment.*

1. Netting resource	
A) Amilan 210 D 3/6	76 m/m × 106 gauge × 1196 mesh
B) Amilan 210 D 3/9	91 m/m × 89 gauge × 997 mesh
C) Amilan 210 D 3/9	106 m/m × 76 gauge × 857 mesh
D) Amilan 210 D 3/12	115 m/m × 71 gauge × 790 mesh
E) Amilan 210 D 3/12	121 m/m × 66 gauge × 750 mesh
F) Amilan 210 D 3/15	130 m/m × 62 gauge × 700 mesh
G) Amilan 210 D 3/15	136 m/m × 59 gauge × 667 mesh
2. Webbing resource	
A) Shrinkage	corkside 43% big bolsh 45%
B) Corkline	Manila rope 2 × 2 20 g × 2 total length 52.6 m
C) Big bolsh line	Manila rope 2 × 2 45 g × 2 total length 50.9 m
D) Float	Synthetic float flat type 220 g net A) B) C)...48 D) E) F) G)...53
E) Sinkers	Cylindrical lead 75 g net A) B) C)...50 D) E) F) G)...55
3. Discrimination	To distinguish the kinds of gill net, each 3 floats at both ends colored

III-2. Oceanographic Survey

Oceanographic variables were measured at the following seventeen standard depths; 0, 10, 20, 30, 50, 75, 100, 150, 200, 300, 400, 500, 600, 800, 1,000, 1,500, and 2,000 meters.

Water temperatures were measured with reversing thermometers and water samples taken with Nansen bottles. The procedures used are outlined in "The Guide Book of Oceanographic Survey (Oceanographical Society of Japan, 1955)". Salinity was determined by Mohr's method before 1966 and by a salinometer (made by Tsurumi Works) since 1966.

III-3. Fishing Gear used for Fish Sampling

For fishing experiments seven different mesh gillnets made of Amilan were used (Table III-3).

A gillnet shackle is about 50 meter long with a depth of about 5.5 meter.

III-3-1. The Kinds of Mesh of Gillnets and their Arrangement

Gillnets have been employed for fishing of near-surface fish, e.g. herring and mackerel, since ancient times (the 12~13th century). According to the fish body size various size meshes are employed (Gall, 1937). To properly employ gillnets for investigating the distribution of fish, the lack of uniform selection of fish body size by the mesh (Fujii et al., 1961, Konda, 1963, Ishida, 1966) and the "throwing direction" of fishing gear (Hartt, 1962, 1966, Johnsen, 1964, Larkins et al., 1964,

Table III-4. Gill net meshes employed in each year 1962-1968 by the Oshoro Maru.

Year	Mesh Size (mm)						
	76	91	106	115	121	130	136
1962	+	+	+	+	+	+	+
1963				+	+	+	+
1964				+	+	+	+
1965		+		+	+	+	+
1966		+		+	+	+	+
1967				+	+	+	+
1968		+		+	+	+	+

+ denotes employment

Table III-5. The standard arrangement of various gill net meshes employed in 1965 by the Oshoro Maru. [mesh size × number of shackles]

115 mm × 4—130 mm × 5—91 mm × 3—121 mm × 3
—121 mm × 13—136 mm × 6—115 mm × 9—
121 mm × 10—130 mm × 9—115 mm × 5—130 mm × 3
—91 mm × 3—121 mm × 14—136 mm × 6—
115 mm × 10—121 mm × 10—130 mm × 9

Table III-6. Number of salmon used for morphometric measurement, the Oshoro Maru, 1962-1968.

Year	Species			Data Rec. Oceanogr. Obs. Expl. Fish. (Hokkaido Univ.)
	Sockeye	Chum	Pink	
1962	402	777	547	No. 7 1963 p.117~138
1963	565	719	429	No. 8 1964 p.268~286
1964	418	576	167	No. 9 1965 p.294~306
1965	420	147	124	No. 10 1966 p.329~339
1966	519	798	296	No. 11 1967 p.234~252
1967	660	648	117	No. 12 1968 p.350~367
1968	1085	1338	289	No. 13 1969 p. 86~118
mean	583	756	290	
%	36	46	18	

Fujii et al., 1968) must be considered.

The author employed gillnets with seven sizes of mesh, between 76 mm and 136 mm in 1962 in order to avoid error due to the selecting ability of fish body size, but then the unfitness of employing the gillnets of smaller mesh size (76 mm~106 mm) for the western Alaska sockeye salmon on the way to homing migration became clear. So, since 1963, the author has employed four sizes of gillnets having meshes of 115, 121, 130 and 136 mm. Normally 100~120 shackles with these sizes were randomly arranged to make each gillnet set.

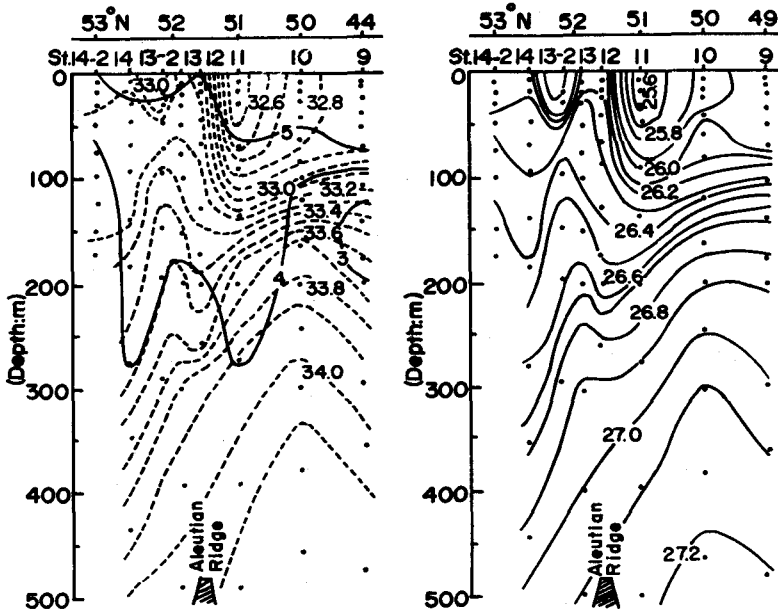

Fig. IV-1. Vertical sections of temperature (°C), salinity (‰) and sigma-t at Amchitka Pass (about longitude 179°W) in middle June, 1963.

The data for every year are shown in Table III-4 for adult sockeye salmon in May~July.

The arrangement of gillnets in 1965 is shown in Table III-5. The setting was generally finished before sunset, and hauling began after sunrise each day.

III-4. Biological Investigation

Biological data collected at each station included body length, body weight, scale test sample, sex identification, the weight of the gonad and weight of stomach contents from over 30 fish of the genus *Oncorhynchus* selected randomly from the various sizes of mesh. The biological data obtained are shown in Table III-6.

IV. Mechanism of Homing Migration of the Western Alaska Sockeye Salmon

IV-1. Reason for the Short Residence Time of the Sockeye Salmon South of the Aleutian Islands

The western Alaska sockeye salmon gather south of the Aleutian Islands during late May through June, and enter the Bering Sea in middle through late June (Manzer et al., 1965). The sockeye salmon that have come to the south side

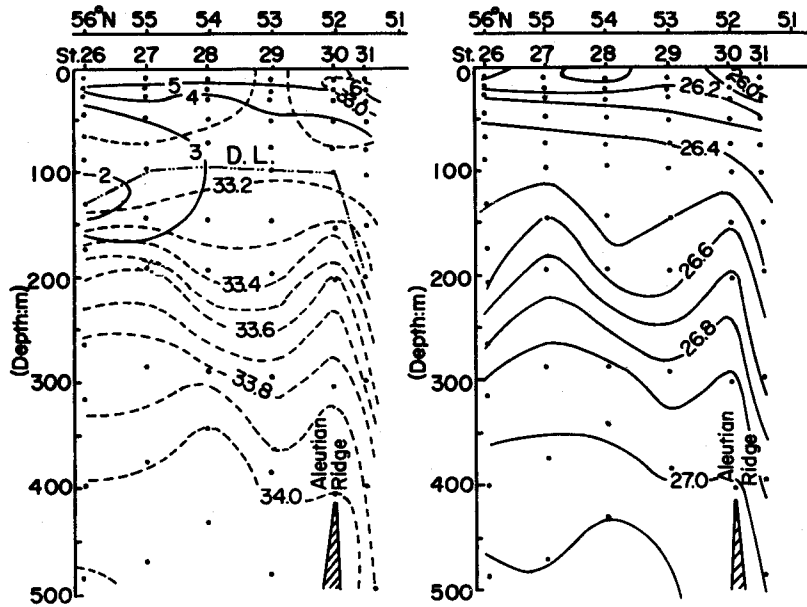

Fig. IV-2. Vertical sections of temperature ($^{\circ}\text{C}$), salinity (‰) and sigma-t at the Pass along 175°E in late June, 1964.

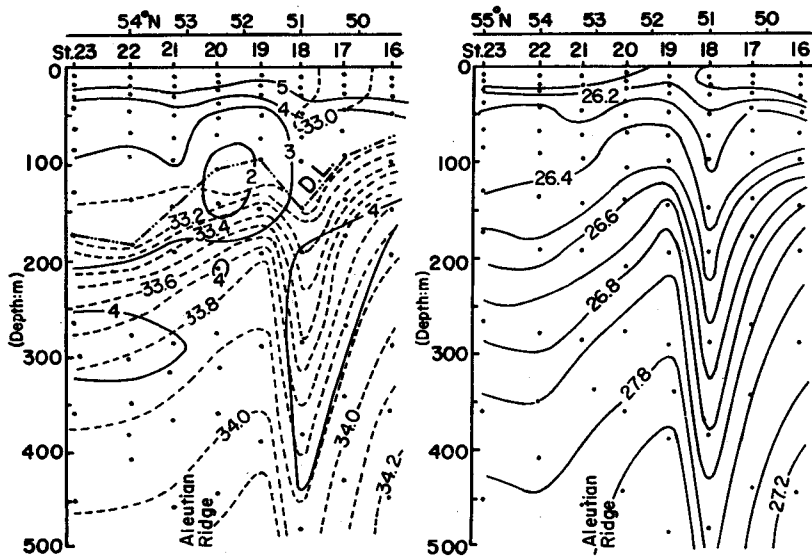

Fig. IV-3. Vertical sections of temperature ($^{\circ}\text{C}$), salinity (‰) and sigma-t at the Pass along long. 173°E in late June, 1964.

do not enter the Bering Sea immediately, but remain there some period before entering through certain passes or channels between the Aleutian Islands.

Judging from cross sections of oceanographic structure south to north in the upper layer, the area to the south has higher water temperatures and lower salinities than in the north. This is more noticeable in the eastern area than in the western (Fig. IV-1~3), due to the influence of the Alaskan Stream which moves westwards along the south side of the Islands. The farther away from the Stream the differences in character are less, and at longitude 173°E only a trace of Alaskan Stream influence remains.

In the deep basin area in the vicinity of the Aleutian Islands, the depth from the sea surface of convection due to cooling in winter differs between the Bering Sea and the North Pacific Ocean, divided by the Islands. The convection layer is deeper in the Bering Sea than in the North Pacific Ocean, therefore, there is observed a difference of the distribution of water temperature and salinity. Thus, the presence of the Aleutian Islands forms a characteristic oceanographic boundary in this area which has an important influence on the distribution and behavior of sockeye salmon.

In the channels or passes between the Aleutian Islands there is observed a distortion of the normal stratified oceanographic conditions. Fig. IV-4 shows differences in the surface water temperature, salinity and the density (σ_t) on the north and south sides of Tanaga Pass, which is the deepest of the eastern passes and through which the most abundant runs of sockeye salmon are observed to pass (Hartt, 1962, 1966). According to Fig. IV-4, the water temperatures are high (about 6.5°C), salinities low (about 32.6‰), and the density (σ_t) is about 25.6 at Stations A, B, and C in the North Pacific Ocean side, but low temperatures (about 5.0°C), high salinities (about 33.3‰), and densities (σ_t) of about 26.3 prevail at Stations F, G, H and I on the Bering Sea side. Discontinuous strata are found in the shallowest part of the channel, and the surface water temperature is the lowest (4.2°C), salinity the highest (33.39‰) and the density (σ_t) is also the maximum (26.5) in the shallowest part. It appears there is an upwelling of the lower layer water in the channel owing to tidal currents and the topography of the sea bottom, and the upwelling leads to extensive vertical mixing, ultimately destroying the stratification. The vertical mixing has only been observed spreading to the north side of the Islands (into the Bering Sea), which suggests a net movement of the mixed water from the channel to the Bering Sea. As also seen in Fig. IV-5, a T-S diagram plotted from the water temperature and salinity at Amchitka Pass, the water in the center of the Pass (St. 12) is the same as that of the layer 75~100 meter shallower in the southern part of the Bering Sea than it is south of the Aleutian Islands. Thus, the presence of low temperature, high salinity water formed in the channels or passes seems a possibility for retarding

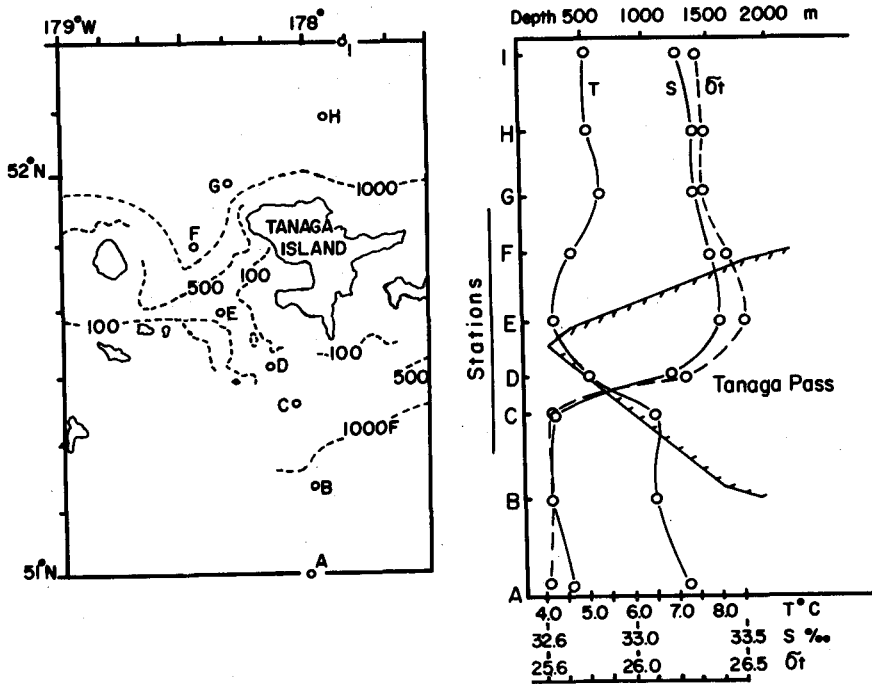

Fig. IV-4. Distribution of stations (left) and the surface distribution of temperature (°C), salinity (‰) and sigma-t (right) in Tanaga Pass, in middle June, 1967.

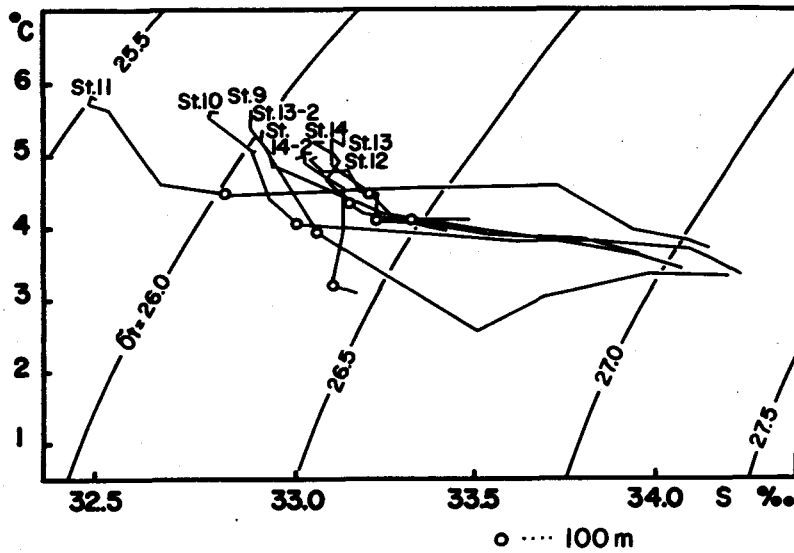

Fig. IV-5. T-S diagram at stations in Amchitka Pass in middle June, 1963.

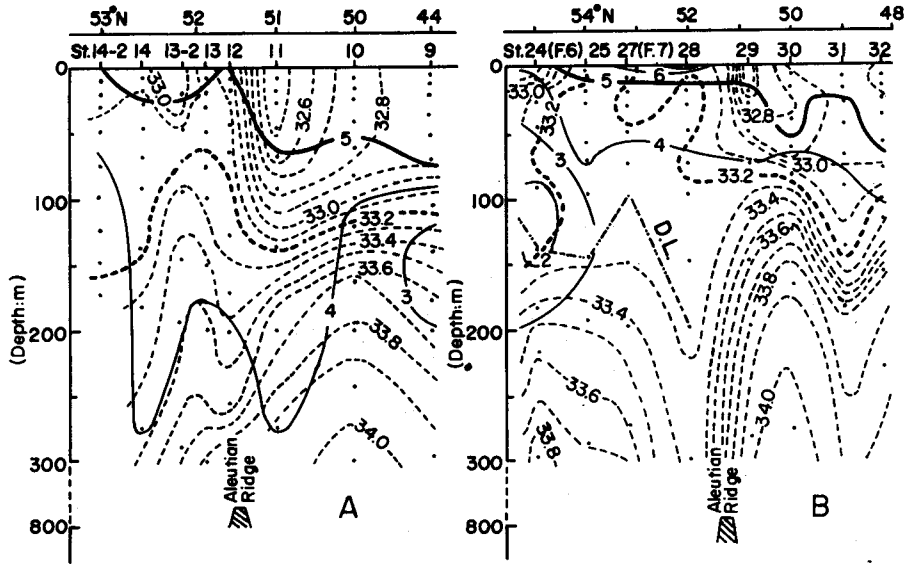

Fig. IV-6-A. Vertical sections of temperature (°C) and salinity (‰) of Amchitka Pass of the normal type (A), and soon after sockeye salmon have passed (B) in Amchitka Pass, in middle June.

sockeye salmon movement into the Bering Sea, and this may also be a reason for their short residence time south of the Aleutian Islands (Fujii, 1969, 1970).

IV-2. Mechanism of Passing of Sockeye Salmon through the Channels or Passes

In the case of the passing of sockeye salmon from the North Pacific Ocean into the Bering Sea, there is formed a normal oceanographic regime due to tidal currents and topographical factors, and their passage may be held back. Even when a few sockeye salmon pass into the Bering Sea, the majority stay south of the Aleutian Islands until the disruption of the normal oceanographical environment, that is, the removal of the vertically mixed water of low temperature and high salinity at the surface which prevents the fish from entering the Bering Sea.

In the Bering Sea the water temperature rises rapidly during June. Fishermen have known from experience that at that time sockeye salmon begin entering the Bering Sea.

Fig. IV-6 shows a normal vertical section of temperature and salinity of Amchitka Pass (A) and a section taken soon after sockeye salmon have passed through the Pass in middle June (B). Soon after sockeye salmon passed through the Pass, the 5°C isotherm, which was observed at 15 meter depth in the center of the Alaskan Stream (50.9°N) south of the Aleutian Islands, reached to the

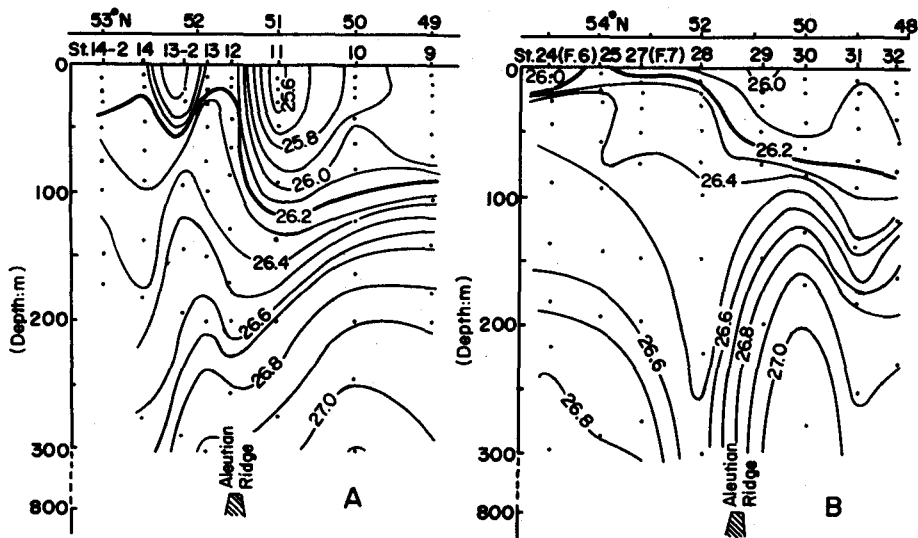

Fig. IV-6-B. Vertical sections of sigma-t of Amchitka Pass of the normal type (A), and after sockeye salmon have passed through (B) in middle June.

surface at 54.5°N north of the Pass. The salinity of the surface layer to the north of the Aleutian Islands showed 33.0~33.2‰, which is somewhat higher than in the body of the Alaskan Stream south of the Islands. But the salinity at the surface at St. 27 was approximately 33.2‰. The isopycnal of $\sigma_t=26.2$ at 75 m depth to the south of the Islands rose to 65 m north of the Pass, and remained at the shallower depth to 54°N.

These observation suggest that the surface water layer of 10~20 meter thickness south of the Aleutian Islands had flowed abundantly into the Bering Sea at this time, and the density of water both north and south of the Islands had become nearly equal, because the density of the surface water of the north side of higher salinity was decreased by the seasonal increase in temperature. Thus, the vertically mixed water having low temperatures and high salinities and hence high density which held back the passage of sockeye salmon, had disappeared, and the major migration of sockeye salmon could begin.

IV-3. Oceanographic Conditions in the Basin Portion of the Bering Sea and Behavior of Sockeye Salmon

IV-3-1. Oceanographic Conditions in the Basin Portion of the Eastern Bering Sea

Horizontal distribution of water temperature and salinity at 20 m and in the dichothermal layer in the Basin Portion of the eastern Bering Sea from June to

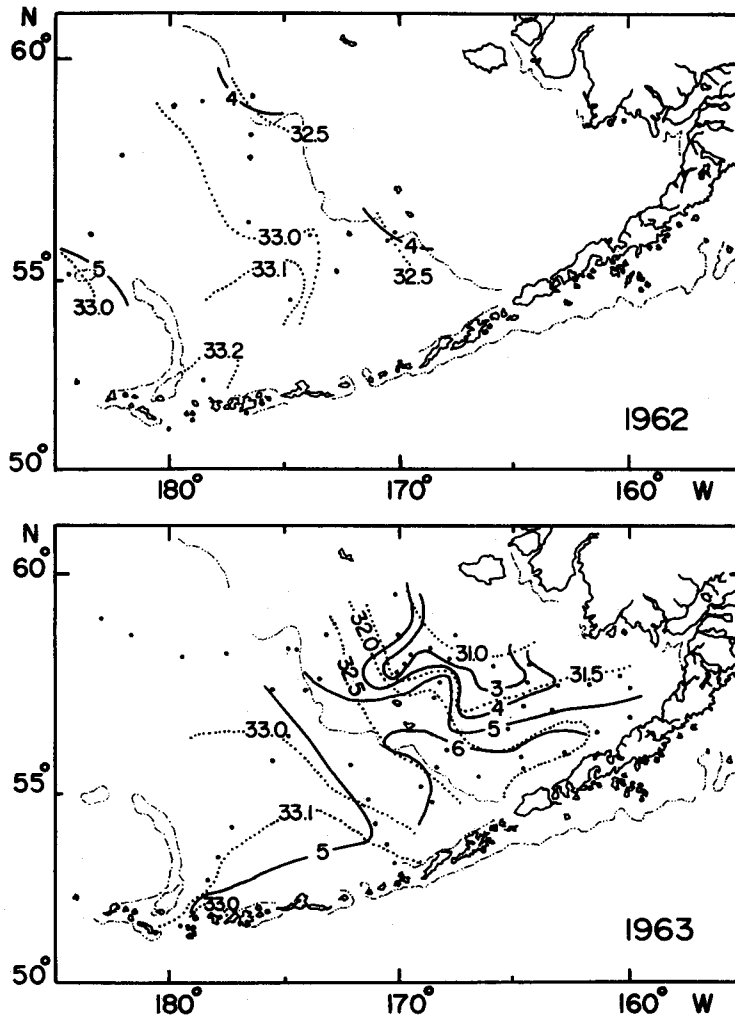

Fig. IV-7. Distribution of temperature ($^{\circ}\text{C}$) and salinity (‰) at 20 meters in the eastern Bering Sea from June to July in each year, 1962-1967.

July each year, 1962~1967, obtained by the author, are shown in Figs. IV-7~8. The reason for choosing 20 meters depth as an experimental layer is from the consideration of the influences of radiant energy in the surface water. The reason for taking dichothermal layer is that the dichothermal layer is the deepest layer influenced by the convection from the surface in winter, and hence the water temperature and salinity of the dichothermal layer in summer are considered to correspond to those of the surface in winter.

As seen in Figs. IV-7~8, the pattern of the horizontal distribution of the

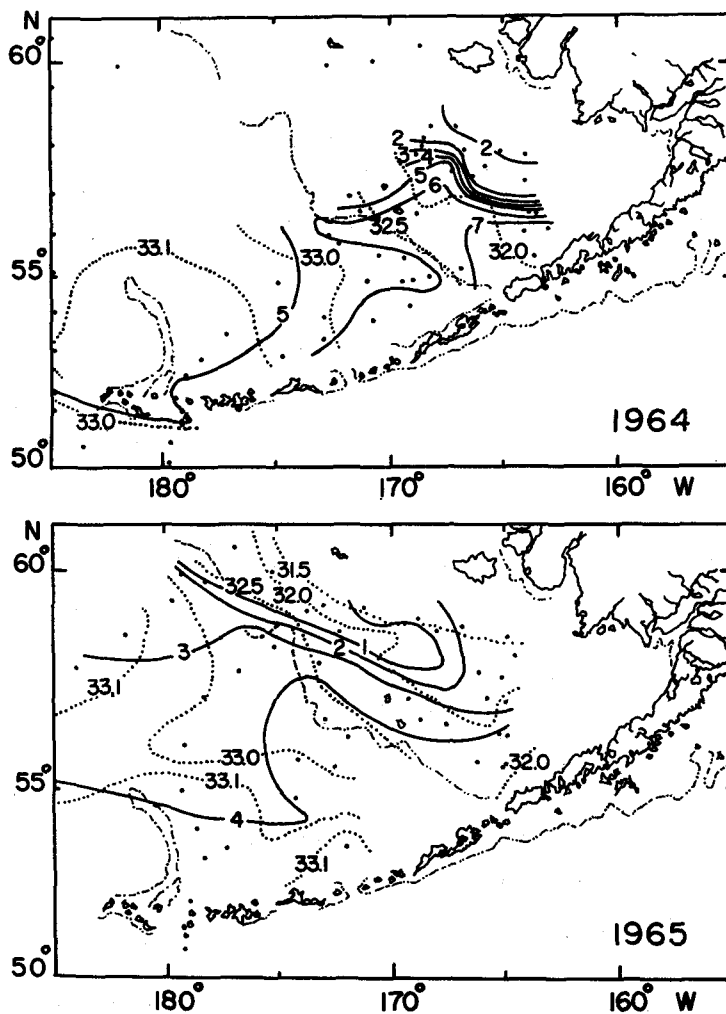

Fig. IV-7. Continued.

temperature and salinity from June to July is similar each year so the average horizontal distribution for six years' observations is plotted in Figs. IV-9~12. Comparison of the distributions at 20 m, and in the dichothermal layers (Figs. IV-9 and 11) shows that the surface layer has been heated by radiant energy in June and July, so a better estimate of the water temperature of the surface layer in winter can be had from the temperature in the dichothermal layer, reduced by 2~3°C for summer heating effects.

The distribution of water temperature at 20 m shows them to be generally high in the south and low in the north. The water temperatures north of the Fox

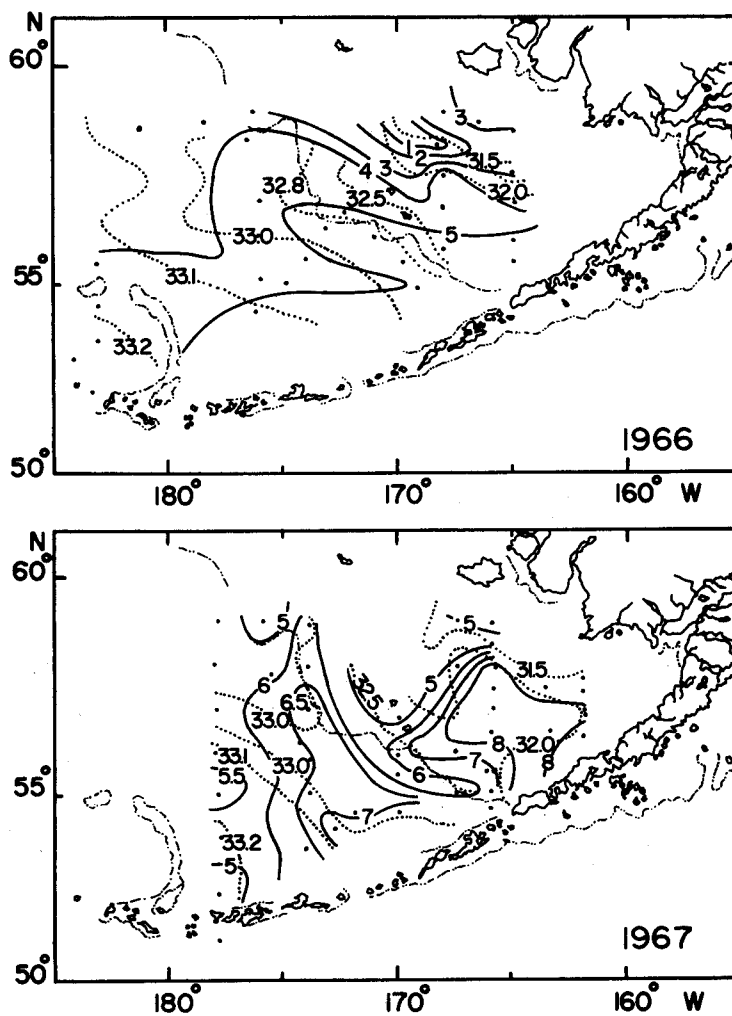

Fig. IV-7. Continued.

Islands, which are in the eastern part of the Basin Portion and are south of 54~55°N, are the highest, about 7°C. In the dichothermal layer in the center of the Bering Sea there is a cold water mass (<3°C) having a boundary trending southeastwards, and the sea area having above 3°C stretches out between the Aleutian Islands and the cold water mass and reaches to nearly 58°N along the eastern continental slope.

As there is observed cold water above 4°C north of the Fox Islands, south of 55°N, this area is presumed to have the highest temperatures in winter of the eastern part of the Bering Sea. As seen in Figs. IV-10 and 12, the salinity of the surface water of the Basin Portion in the eastern Bering Sea is higher (>33.0‰)

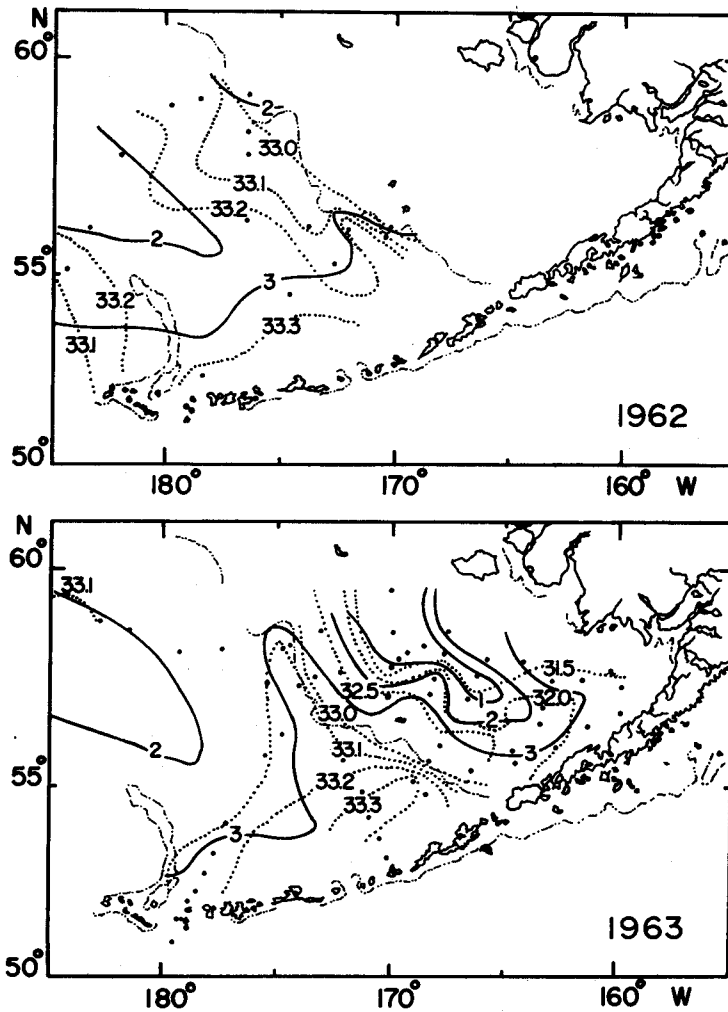

Fig. IV-8. Distribution of temperature ($^{\circ}\text{C}$) and salinity (‰) in the dichothermal layer over the basin and sea bottom over the continental shelf in the eastern Bering Sea from June to July in each year, 1962-1967.

than that of the surface water of the surrounding sea area, in contrast with $<33.0\text{‰}$ to the south of the Aleutian Islands and over the continental shelf.

As seen in Fig. IV-10, the salinity at 20 m becomes lower proceeding northwards from the north edge of the central Aleutians, west of Amukta Island; and the area having less than 33.1‰ spreads widely north of latitude 55°N . North of latitude 57°N the salinity becomes again $>33.1\text{‰}$. A water mass with salinity $<33.0\text{‰}$, which stretches northwards along the continental shelf, spreads westwards

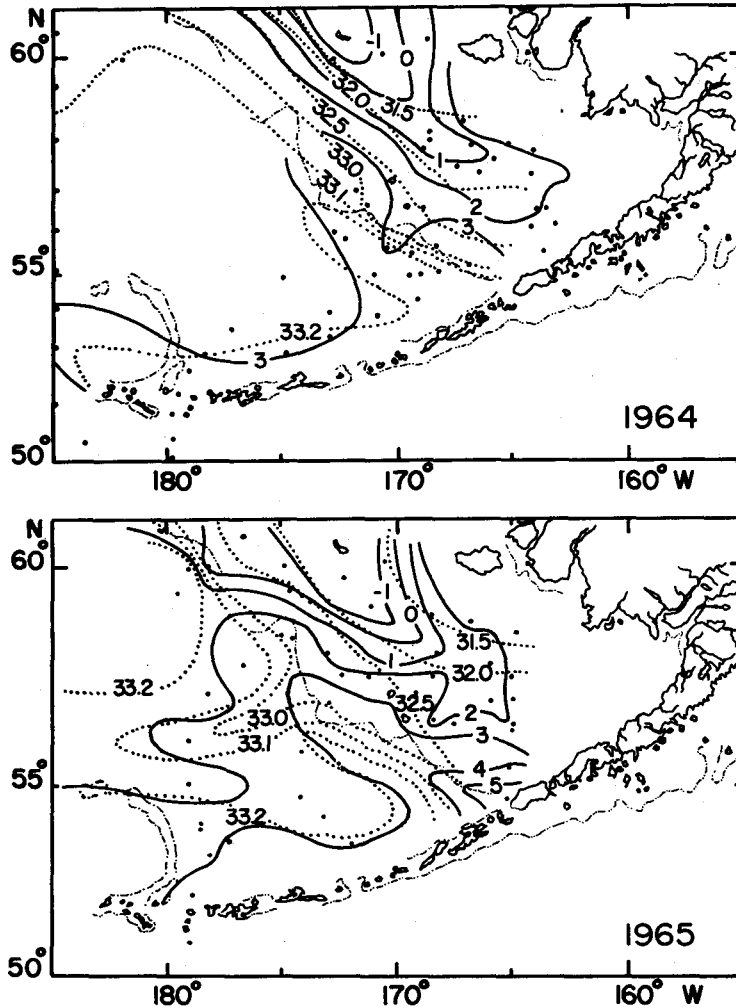

Fig. IV-8. Continued.

in the region at approximately 56°N over the central part of the eastern Bering Sea.

As seen in Fig. IV-12, the distribution of the salinity of the dichothermal layer corresponds with that at 20 m, that is, the salinity is the highest (33.3‰) at the north edge of the central part of the Aleutian Islands, from the Amukta Island westwards to the Rat Islands. At latitudes 55~57°N, a water mass having less than 33.2‰ spreads westwards.

From the observations described above, it can be said that the salinities of the southern part of the Basin Portion of the Bering Sea are higher than those

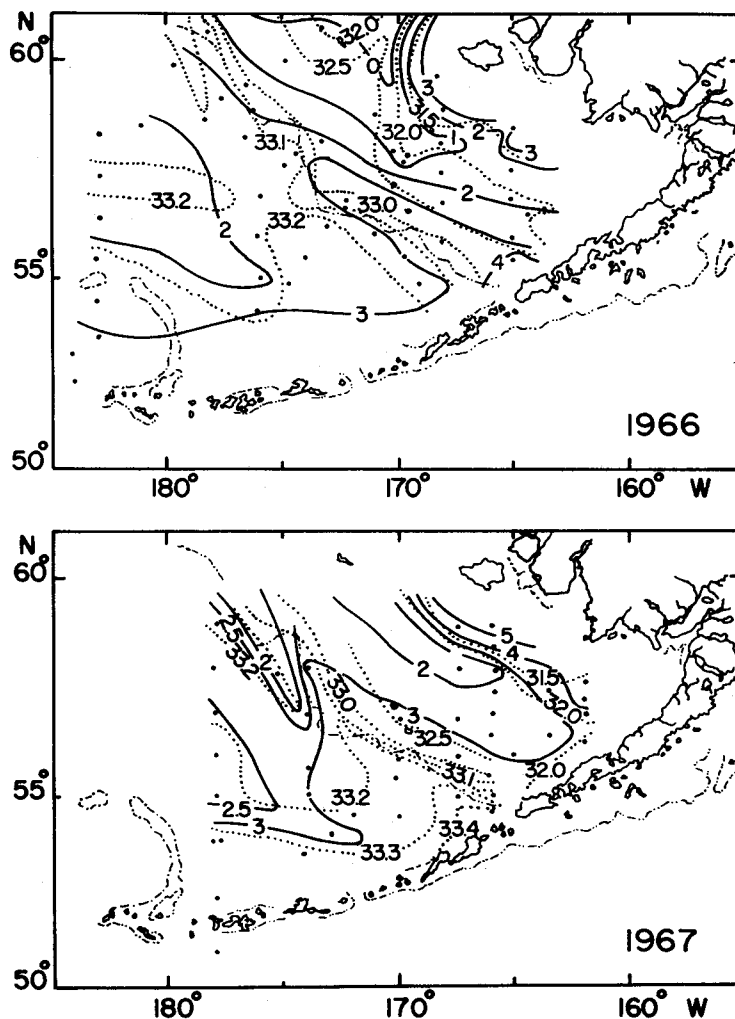

Fig. IV-8 Continued.

north of latitude 55~56°N. This is considered to be due to the fact the vertically mixed water in the passes between the Islands under influence of Alaskan Stream water, flows into the Bering Sea as comparatively high salinity water (>33.0‰). Vertical sections of water temperature, salinity and density (σ_t) along longitude 179°W in early June, 1965, are shown in Fig. IV-13; along longitude 176°W, middle June, 1966, in Fig. IV-14; and along longitude 177°E, at the same period, in Fig. IV-15.

According to these results, there exists in spring a layer of low salinity water (<33.0‰) which lies at 170~300 m in the Basin Portion of the eastern Bering

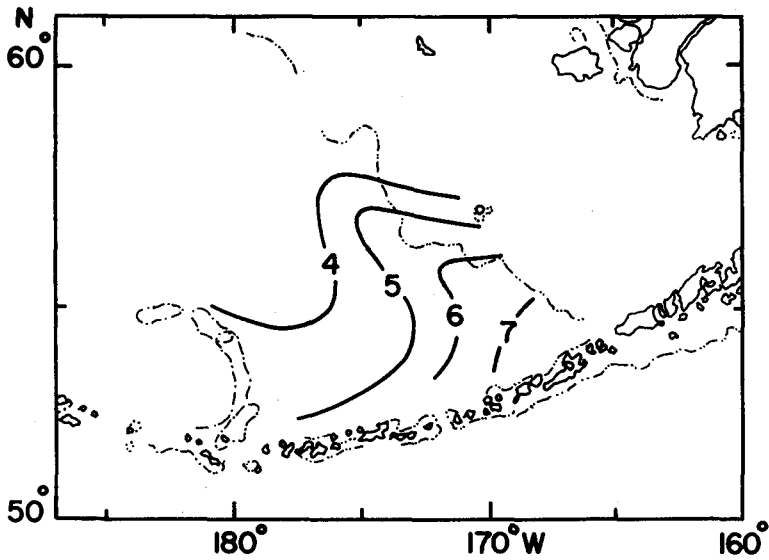

Fig. IV-9. Distribution of mean temperature (°C) at 20 meters over the basin in the eastern Bering Sea in June, 1962-1967.

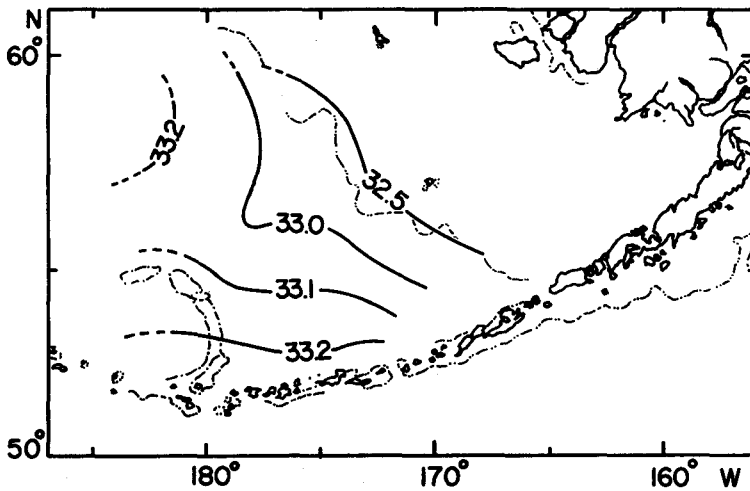

Fig. IV-10. Distribution of mean salinity (‰) at 20 meters over the basin in the eastern Bering Sea in June, 1962-1967.

Sea, in the dichothermal layer at 100~200 m, and in shallower layers down to 75 m near latitude 56°N and extending west to longitude 177°E.

As seen in Fig. IV-13, there is a distinct halocline at 20 m at the south edge of the low salinity water mass, beneath which the dichothermal layer can be

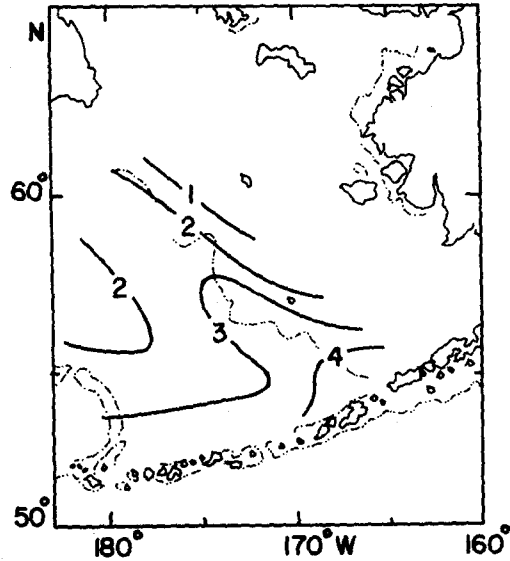

Fig. IV-11. Distribution of mean minimum temperature ($^{\circ}\text{C}$) in dichothermal layer over the basin in the eastern Bering Sea in June, 1962-1967.

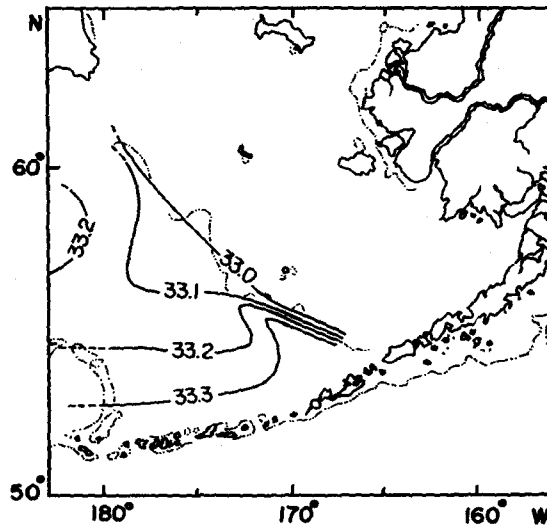

Fig. IV-12. Distribution of mean salinity (‰) in dichothermal layer over the basin in the eastern Bering Sea in June, 1962-1967.

observed. This layer is thinner than to south or north, where the temperature is comparatively high. This suggests that even in winter comparatively high temperature-low salinity water is supplied into the area occupied by the salinity

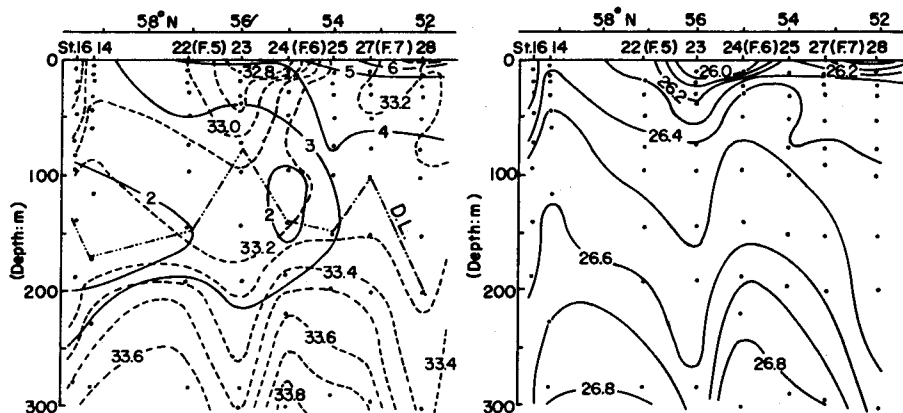

Fig. IV-13. Vertical sections of temperature ($^{\circ}\text{C}$), salinity (‰) and sigma-t along long. 179°W in the Bering Sea in early June, 1965.

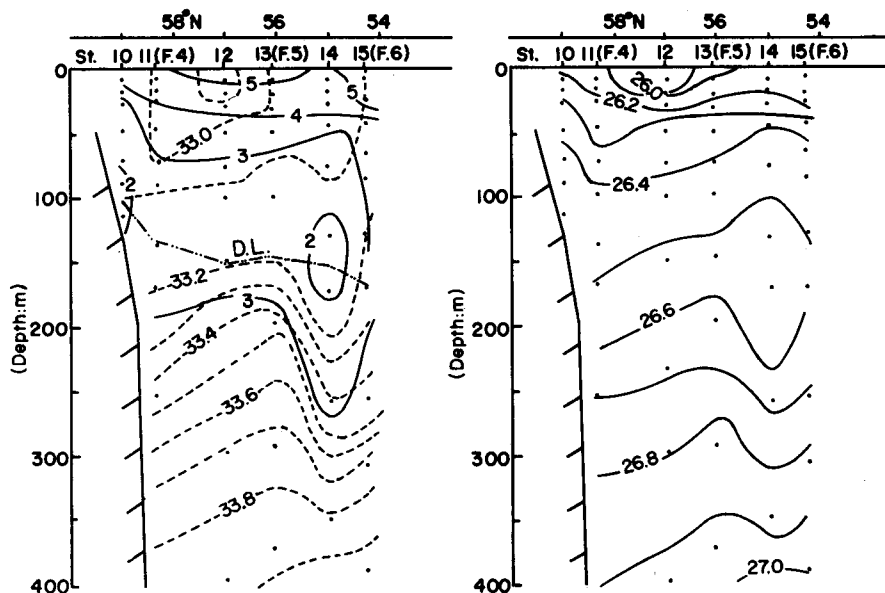

Fig. IV-14. Vertical sections of temperature ($^{\circ}\text{C}$), salinity (‰) and sigma-t along long. 176°W in the Bering Sea in middle June, 1966.

water in summer.

The distribution of the density (σ_t) corresponds to that of salinity, that is, the density (σ_t) in the low salinity water area is 26.1 west of 177°E .

The low salinity layer in the Basin $170 \sim 300$ m can be divided into upper and lower layers. The isohaline of 33.0‰ observed at the surface near 56°N extends

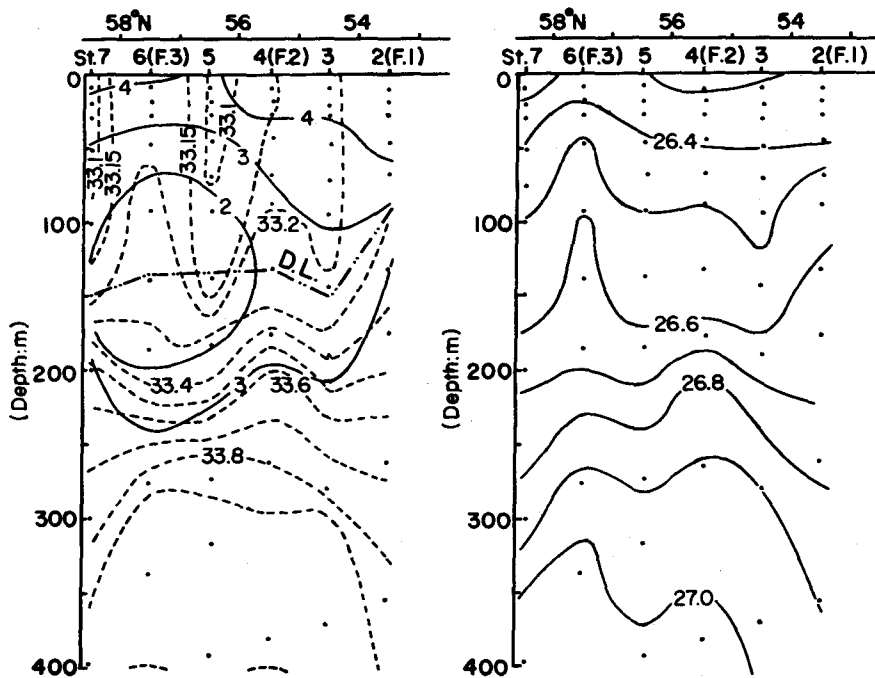

Fig. IV-15. Vertical sections of temperature ($^{\circ}\text{C}$), salinity (‰) and sigma-t along long. 177°E in the Bering Sea in middle June, 1966.

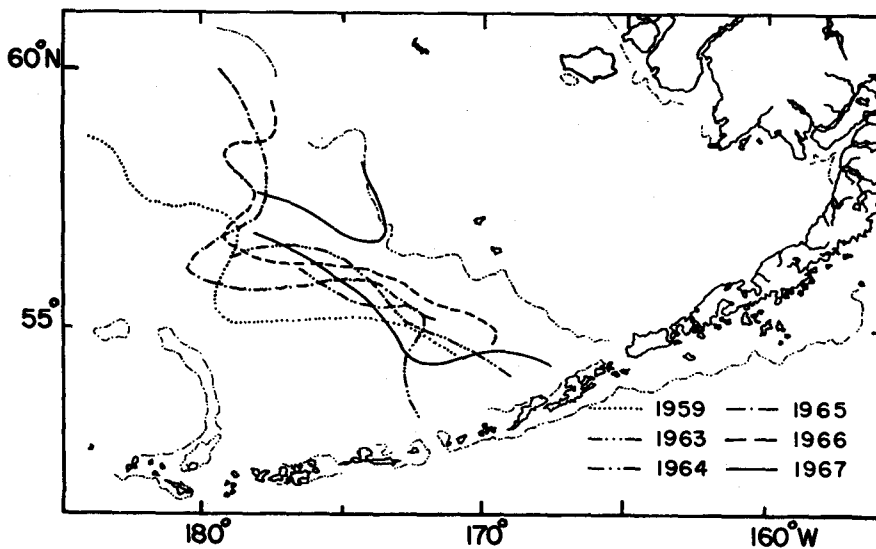

Fig. IV-16. Distribution of 33.0‰ isohaline at 20 meters in the eastern Bering Sea, from June to July, 1959 and 1963-1967.

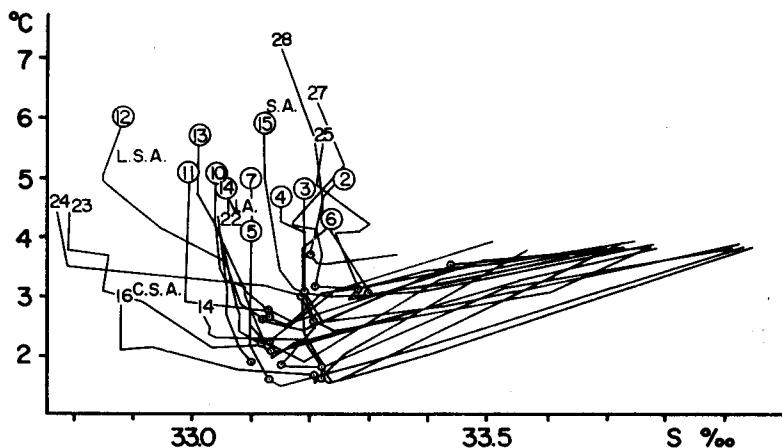

Fig. IV-17. T-S diagram of continental slope stations in the eastern Bering Sea, 1965 and 1966.

St. No. 1965 St. No. ○ 1966 S.A. South area N.A. North area L.S.A. Lower salinity area C.S.A. Continental slope area ⊙ 100 meter depth

northwestwards along the continental slope from north of the easternmost Aleutian Islands, and protrudes westwards to almost 180° at $56\sim 57^\circ\text{N}$. The westward extent of the low salinity area, as seen in Fig. IV-16, varies each year.

Fig. IV-17 shows T-S diagram from stations in the eastern Basin. In the south and north areas, separated by the low salinity area, the water temperature in the south is generally higher than in the north, and the salinity is similarly higher in the south than the north.

The salinity of the surface water is less than 33.0‰ in the low-salinity area, and the low salinity area can be distinguished from the Basin waters in both the south and north areas. The salinity of the low-salinity area is almost equal to that of the continental slope area, while the salinity of the low-salinity water observed in the east longitude area (177°E) is not markedly different from that in both the south and north areas.

Fig. IV-18 shows dynamic heights in the upper layer of the Basin Portion of the Bering Sea in June, 1965 and 1966. As interpreted from Fig. IV-18, the Alaskan Stream on entering into the Bering Sea proceeds eastward along the north side of the Aleutian Islands, then changes its course northwestward near the continental slope. The southeastern area of the Bering Sea belongs oceanographically to the basin portion of the Stream. A part of the Stream is wide from south to north ($40\sim 50$ miles), and extends westwards near $56\sim 57^\circ\text{N}$. In each of the areas of the Alaskan Stream anticlockwise currents are observed. The south and north sea areas are considered to be different water masses, that is, the water in the south sea area is considered to belong to the Alaskan Stream, and the water

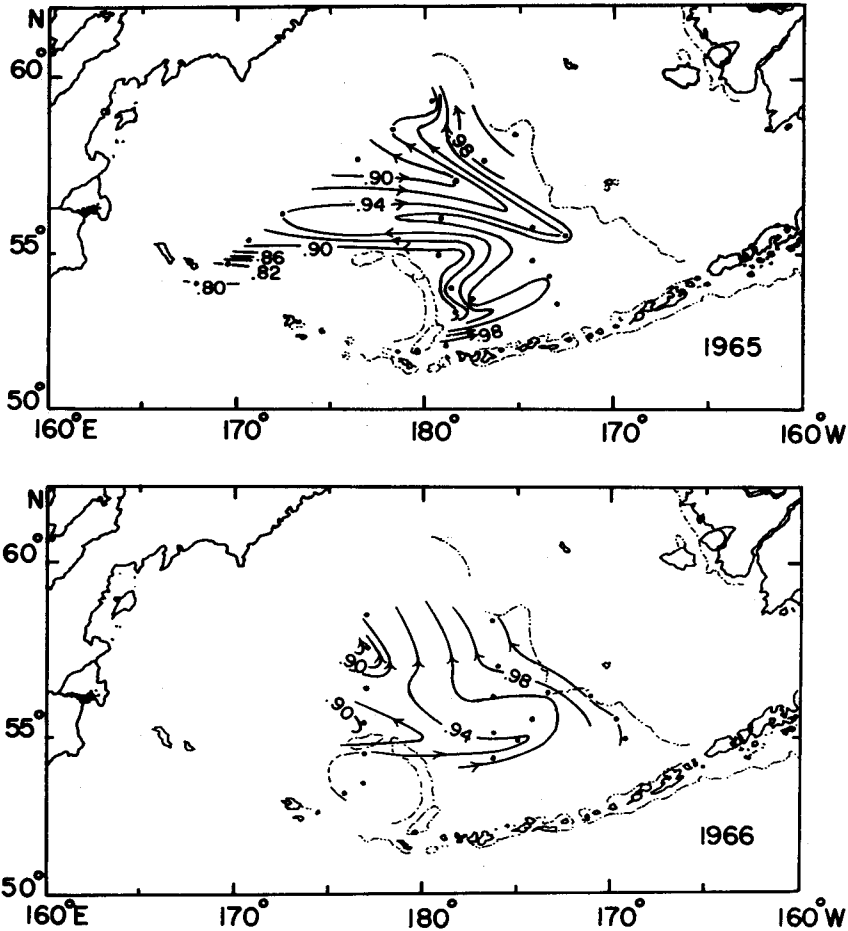

Fig. IV-18. Dynamic heights in the deep basin of the Bering Sea, 0/800 decibars, in June, 1965 and 1966.

in the north sea area is water which wintered in the Sea Ice Domain.

The low salinity water system extending westwards in to the eastern Basin area is a branch of the mixed water current which flows northwestwards along the continental slope, and it is separated from the Basin water by the 33.0‰ isohaline. The north edge of the Basin is considered important because the western Alaska sockeye salmon are caught there abundantly.

IV-3-2. The Behavior of Sockeye Salmon in the Basin Portion of the Bering Sea

The *Oshoro Maru* and an exploratory fishing vessel belonging to the Kyokuzan Maru fleet (here after this is called the K-fleet exploratory vessel) carried out on

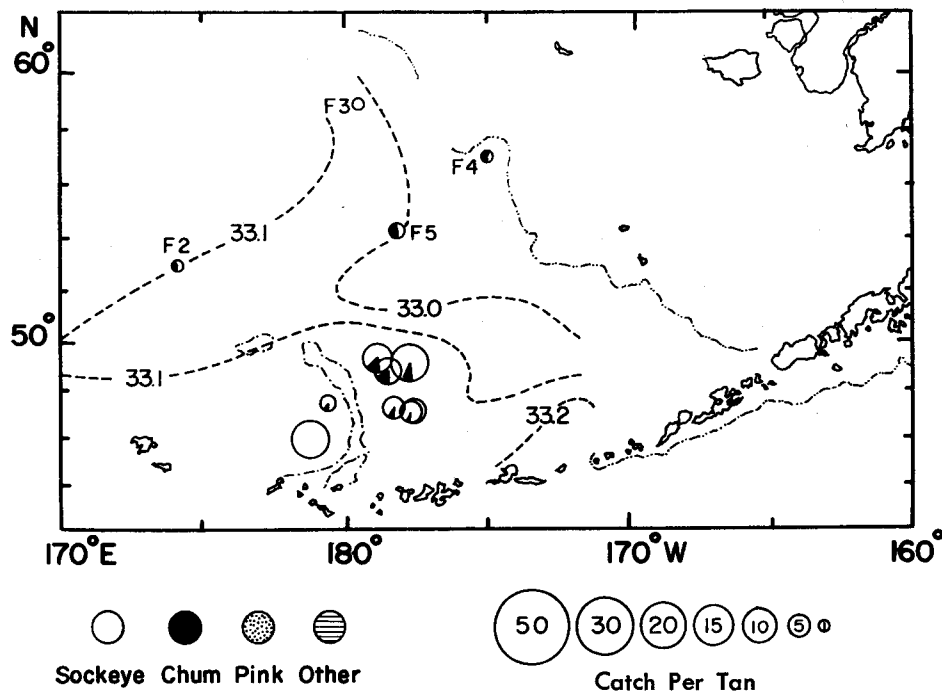

Fig. IV-19-A. Catch of salmon by the *Oshoro Maru* and K. fleet exploratory vessel in early June, 1965.

investigation in early June 1965 over the whole area of the eastern Basin of the Bering Sea.

Fig. IV-19 (-A, -B, -C) show the distribution of *Oncorhynchus* every 10 days in the month (See Table 1).

Early June: In the southern part of the Basin it was observed that the catch varied between 0.1~4.5 fish of the genus *Oncorhynchus* per tan (tan=shackle) with an average of 2.6 per tan. Sockeye salmon was the majority (88.4%), and chum salmon were scarce (11.6%). The water temperature was 3.7~4.8°C. In contrast, in the northern part of the Basin the density of fish was remarkably low (1.2 fish per tan) in which chum salmon were highly mixed (33.3%), and the water temperature was 2.7~4.4°C.

Middle June: In the southern part the exploratory vessel observed almost pure catches of sockeye salmon (99.%), the density of fish was higher than early June (1.4~26.0 per tan, average 8.36 per tan), and the distribution area of this dense school extended northeastwards. The water temperature during this period was 5.0~6.4°C.

Late June: The distribution density of the genus *Oncorhynchus* generally decreased rapidly in the eastern part of the Basin (0.9~4.7 per tan, average 3.4

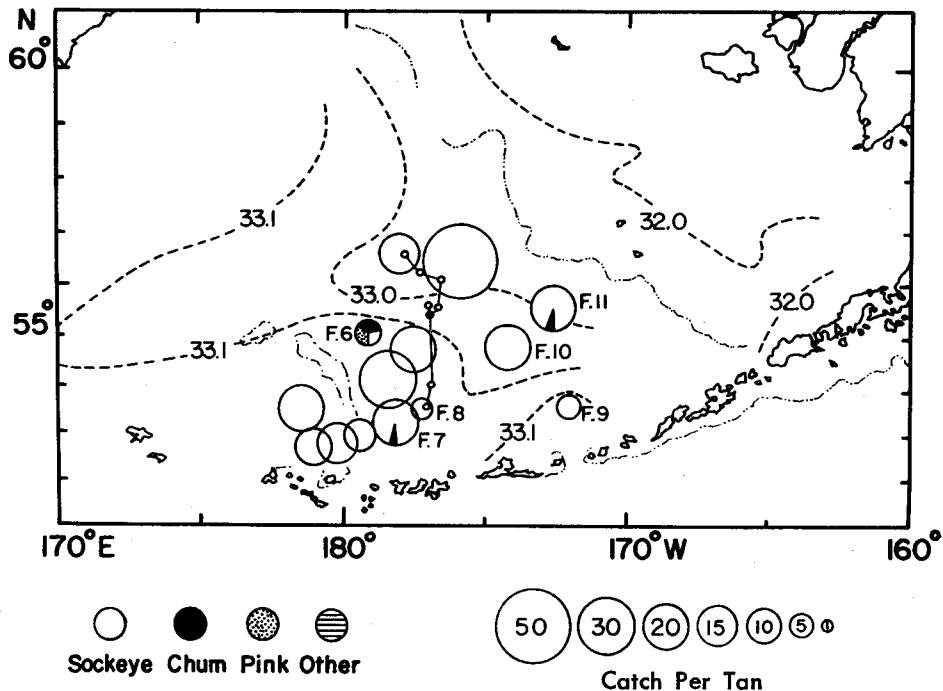

Fig. IV-19-B. Catch of salmon by the *Oshoro Maru* and K. fleet exploratory vessel, and K. fleet cruises in middle June, 1965.

per tan), especially the ratio of sockeye salmon went down (41%). The water temperature was 3.9~6.2°C. On the other hand, in the continental shelf area, dense sockeye salmon school were observed (99% of sockeye salmon) distributed (55.7 per tan) in the southern area of the mouth of Bristol Bay. At the same time in the northern area of the mouth of Bristol Bay thin distribution of sockeye salmon were observed (1.1~3.2 per tan, average 2.4 per tan), of which the predominant group was chum salmon. The distribution of sockeye salmon was very thin (0.1~1.8 per tan, average 0.9 per tan).

The data obtained are not sufficient to deduce the behavior of salmon schools in the Basin Portion of the Bering Sea, but at least in 1965 it can be deduced that sockeye salmon schools began entering the Bering Sea through the channels or passes in early June, and reached their maximum concentration in the middle of June when they then covered the whole area of the Basin. The residence time in the Basin was not long, as the predominant schools went eastwards in late June to the continental shelf in the southern part of Bristol Bay, and subsequently the concentration in the Basin of salmon declined rapidly. The northern limit of the distribution of sockeye salmon in the Basin was generally speaking near

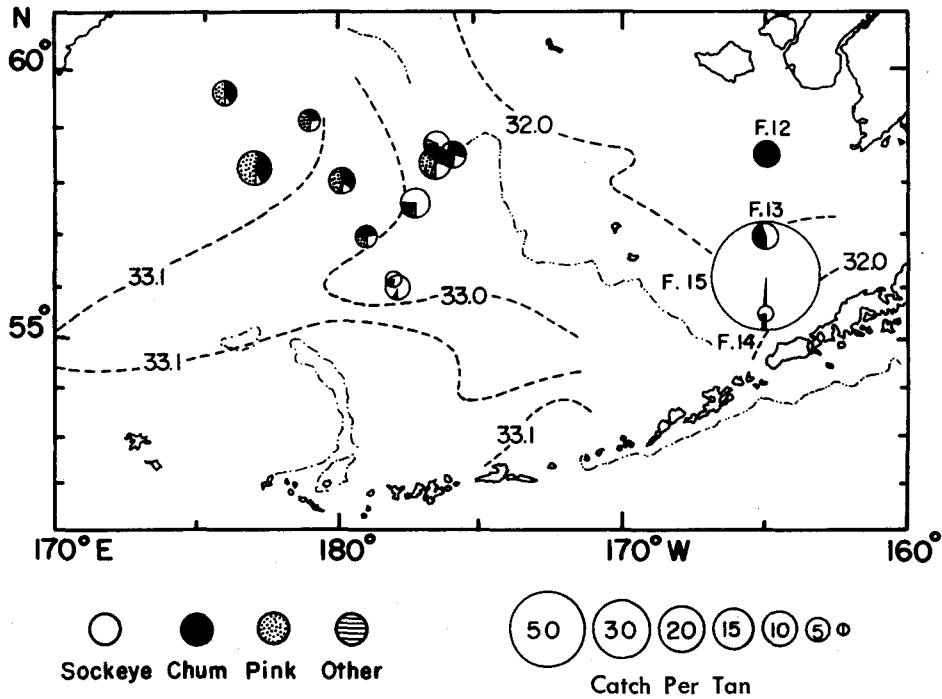

Fig. IV-19-C. Catch of salmon by the *Oshoro Maru*, K. fleet exploratory vessel and S. fleet in late June, 1965.

57°N, as there were very few sockeye and chum salmon found north of this latitude.

IV-4. Oceanographic Conditions over the Continental Slope Area of the Eastern Bering Sea and the Behavior of Sockeye Salmon

Gershanovich (1962) reported that the depth of the continental shelf boundary (the edge of the continental shelf, where the bottom topography is extremely rough), is somewhat less than 200 meters, and the average depth of the boundary in the Bering Sea is about 150 meters.

The author defines the area of the continental slope as the area from the boundary of the continental shelf having depths of 150~200 meters to the deepest depths of the Basin (Fig. IV-20).

As stated previously, this continental slope area is not only the area where offshore water of the Basin meets with the coastal water of the continental shelf, but also the area where the higher temperature water flows northwards, as seen in Figs. IV-21 and 22. This current, as Dodimead (1958) said, may form the mixed water area influenced to a considerable degree by Alaskan Stream water, or may correspond to the Transverse Current of Dobrovolskii and Arsenev (1959).

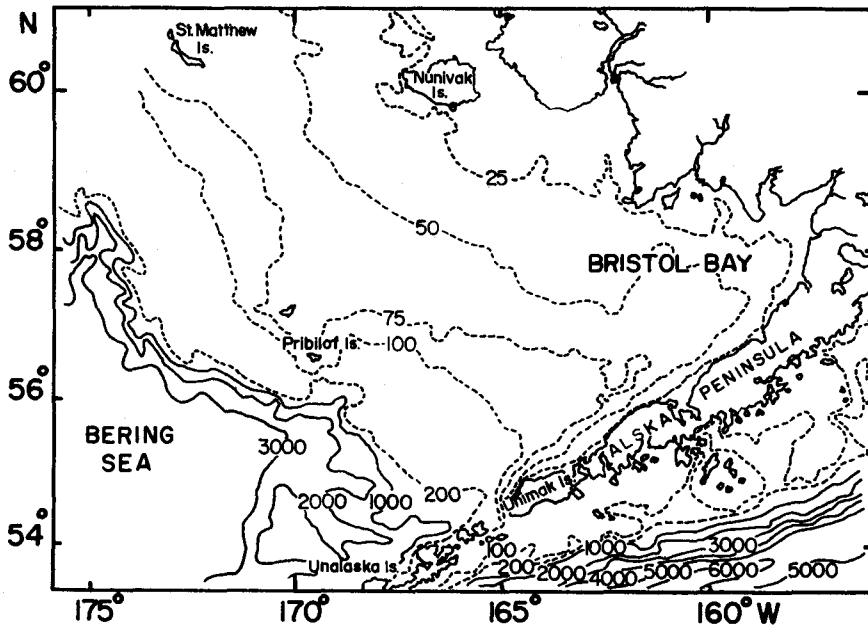

Fig. IV-20. Isobaths in the southeastern Bering Sea. (Dodimead et al., 1963)

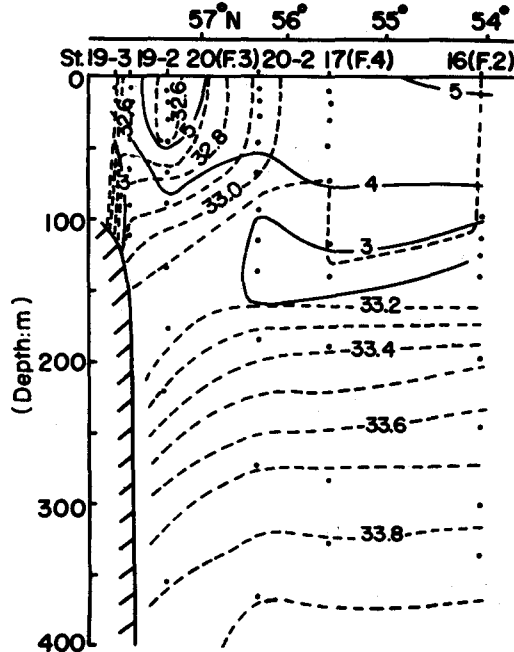

Fig. IV-21. Vertical sections of temperature ($^{\circ}\text{C}$) and salinity (‰) from Amchitka Pass north-northeast to the continental slope in middle June, 1963.

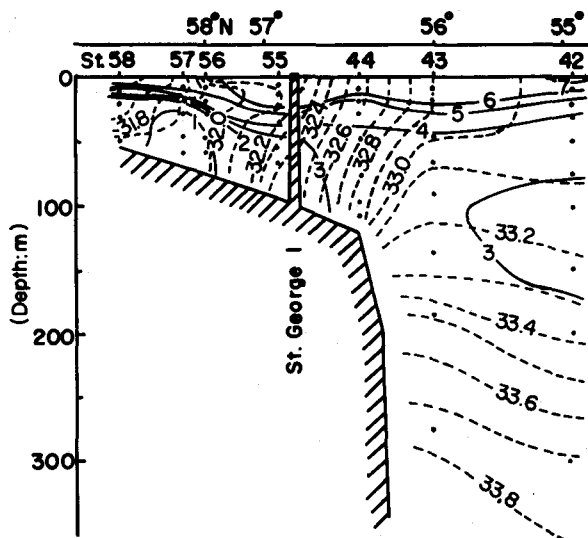

Fig. IV-22. Vertical sections of temperature ($^{\circ}\text{C}$) and salinity (‰) from Amchitka Pass northeast of the continental slope in middle June, 1964.

According to the distribution of water temperature (Figs. IV-9 or 11), the Alaskan Stream, entering the Bering Sea through channels or passes between the eastern Aleutian Islands, certainly flows northwestwards along the continental slope or the continental shelf edge. As seen in Fig. IV-11, the distribution of water temperature in the dichothermal layer, the isotherm of 3°C extends northwards near 58°N through the continental slope area. In this area the water temperatures are higher than those of the continental shelf area or the Basin located to the east and west, respectively. The continental slope area has large horizontal gradients of salinity (See Fig. IV-21, 22), and it is a mixed water area having remarkable current rips (personal observation).

The Transverse Current forms a belt with a width of 80 miles (Fig. IV-10), of which the edge of the continental shelf is the center. The salinity of the center line of the Transverse Current was 33.0‰ in dichothermal layer and 32.5‰ at 20 meters. The temperature of the Transverse Current was $>2\sim 3^{\circ}\text{C}$ in the dichothermal layer. The mixed water of the current may be distinguished from offshore water of the Basin on the basis of temperature and salinities of 33.0‰ , and from the continental shelf coastal water with $S=32.0\text{‰}$. The inclination of the bottom is not steep in the continental slope area from the Pribilof Islands to Unimak Island.

It is clear according to the salinity distribution (Fig. IV-26, 28) that a part of the Alaskan Stream which enters the Bering Sea through channels or passes

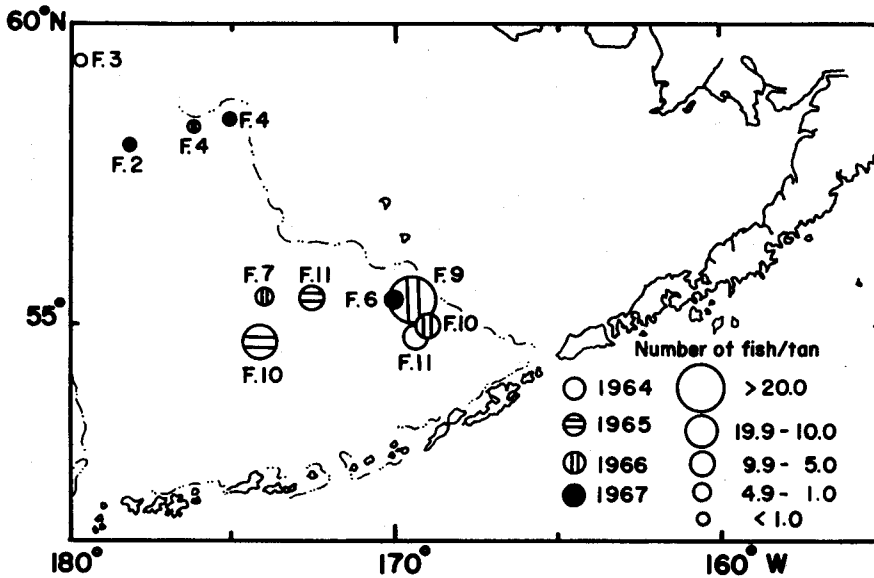

Fig. IV-23. Difference in catch per unit effort (number of fish per tan) of the western Alaska sockeye salmon between the southern area and northern area of the continental slope in each year of exploratory fishing by *Oshoro Maru*.

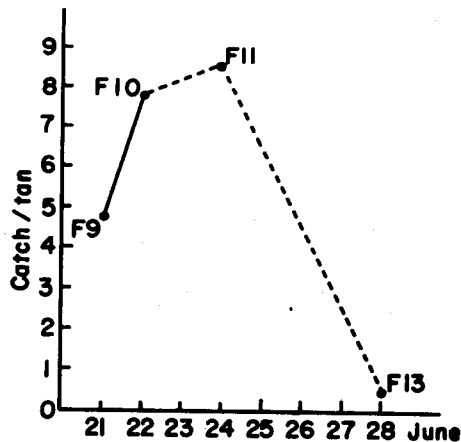

Fig. IV-24. The change of catch of sockeye salmon at the same position (54.9°N, 169.4°W) over the continental slope of the southeastern Bering Sea, June 1964.

between the eastern Aleutian Islands, e.g. Unimak Pass, together with the Bering Sea water flowing eastwards along the north side of the Islands flows onto the continental shelf from the continental slope area.

Thus across the continental slope area extending south to north in the eastern

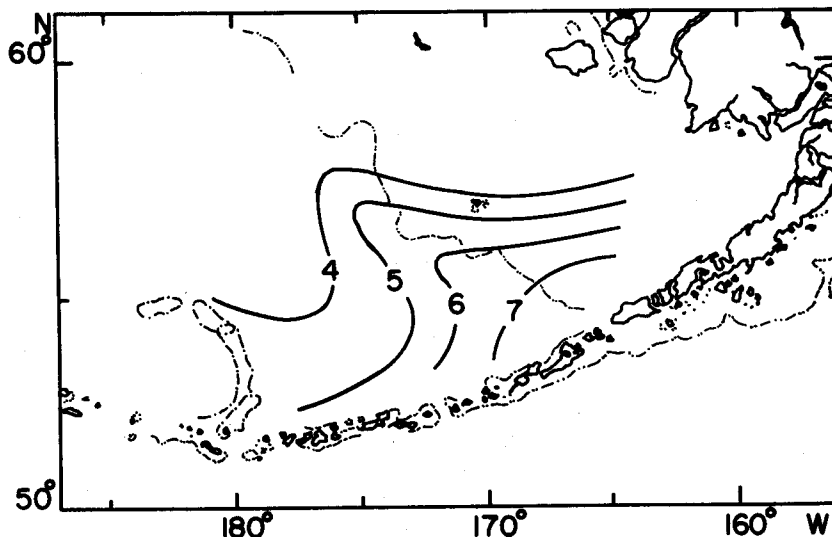

Fig. IV-25. Distribution of mean temperature ($^{\circ}\text{C}$) at 20 meters in the eastern Bering Sea, June-July, 1962-1967.

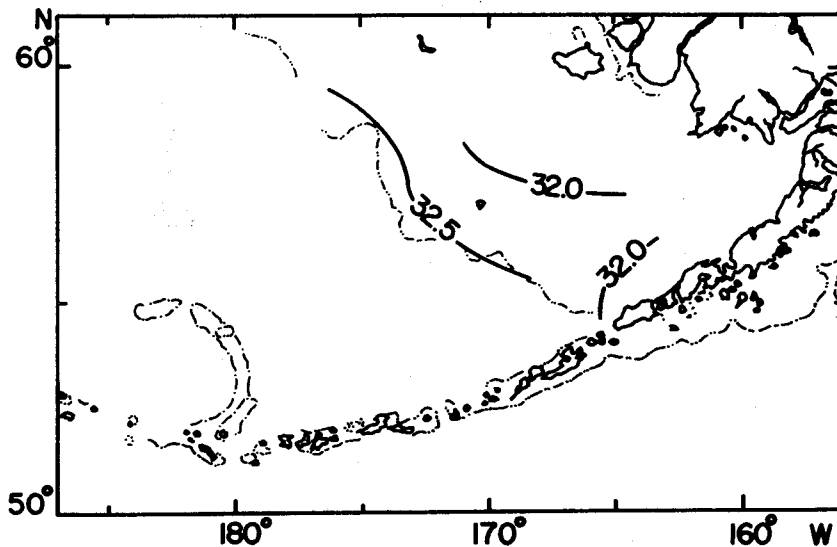

Fig. IV-26. Distribution of mean salinity (‰) at 20 meters in the eastern Bering Sea, June-July, 1962-1967.

Bering Sea is a mixed water area having large horizontal gradients of salinity, and north of this area there is the area ice-covered in winter, which produces the remarkable difference in water temperature between southern and northern areas.

These oceanographic conditions in the continental shelf and slope areas are

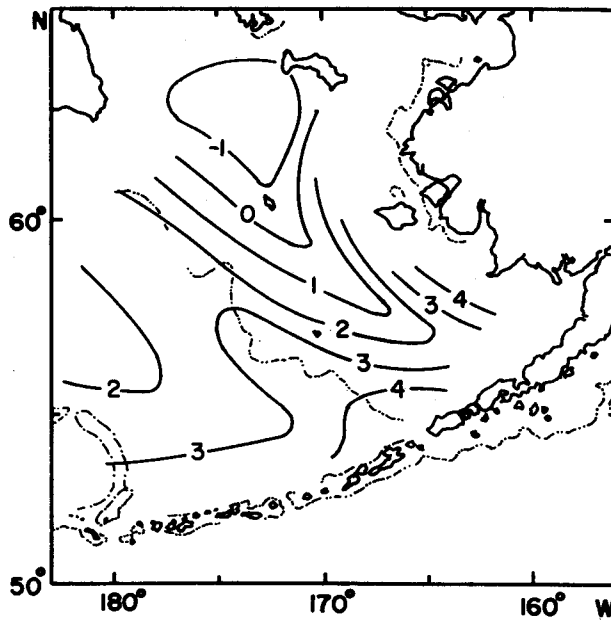

Fig. IV-27. Distribution of mean temperature ($^{\circ}\text{C}$) in the dichothermal layer over the basin and sea bottom over the continental shelf in the eastern Bering Sea, June-July, 1962-1967.

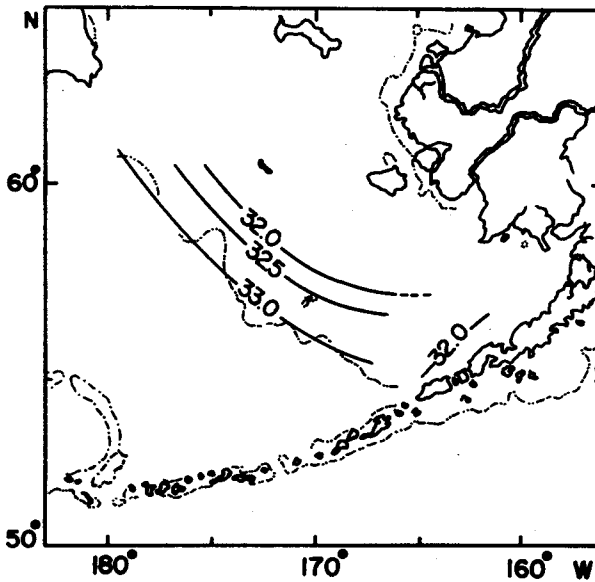

Fig. IV-28. Distribution of mean salinity (‰) in the dichothermal layer over the basin and sea bottom over the continental shelf in the eastern Bering Sea, June-July, 1962-1967.

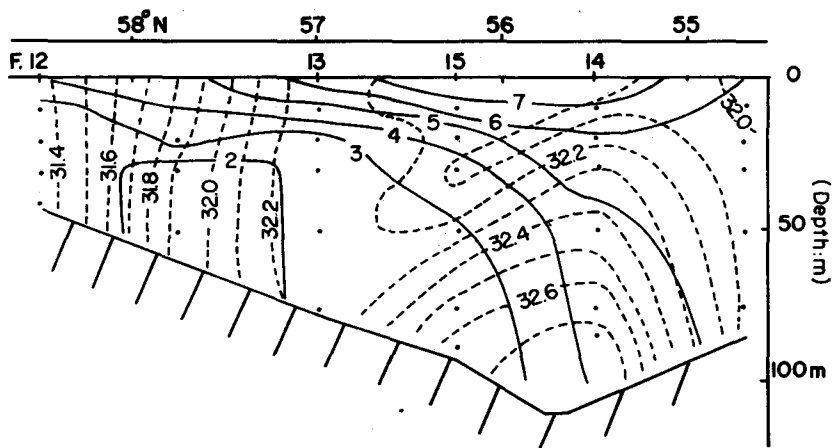

Fig. IV-29. Vertical sections of temperature (°C) and salinity (‰), and exploratory fishing stations along long. 165°W in late June, 1965.

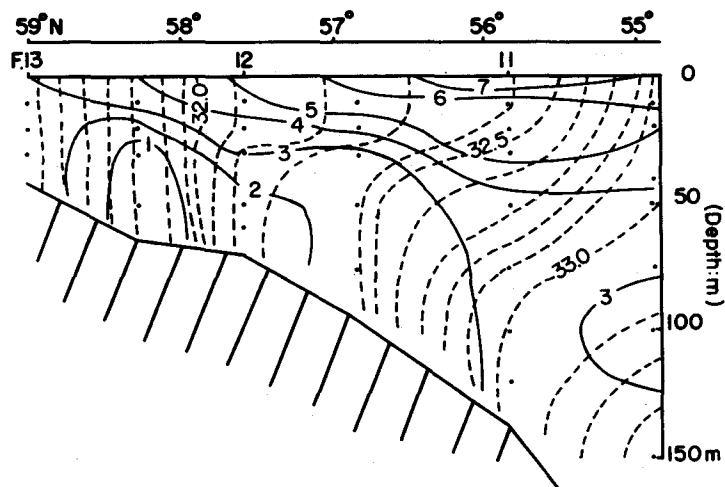

Fig. IV-30-A. Vertical sections of temperature (°C) and salinity (‰), and exploratory fishing stations along long. 168°W in late June, 1966.

considered to have some important effects on the osmotic action of sockeye salmon which migrate eastward from the Basin to continental shelf area. According to the distribution of sockeye salmon in the continental slope area (Fig. IV-23), their concentration is dense in the area south of the Pribilof Islands, and thin in the northwest area. According to the investigation of late June 1964, at the same position (54.9°N. 169.4°W) south of the Pribilof Islands, the catch of sockeye salmon increased for three days at F 9 to F 11, as seen in Fig. IV-24. After that time a depression passed 57°N from west to east, and the investigation stopped, but

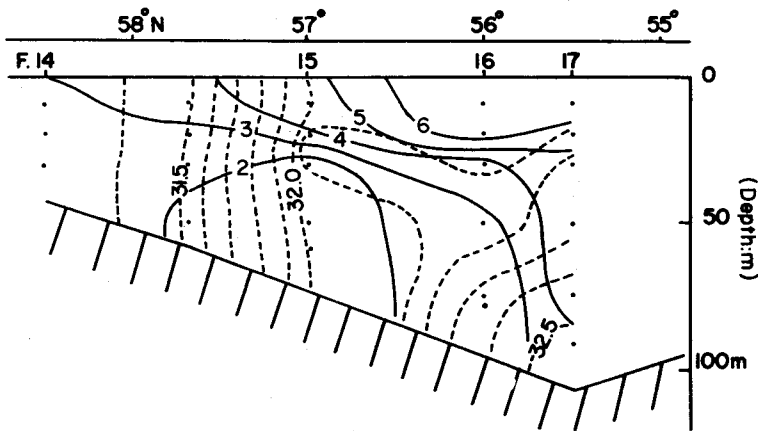

Fig. IV-30-B. Vertical sections of temperature ($^{\circ}\text{C}$) and salinity (‰), and exploratory fishing stations along long. 165°W in late June, 1966.

the density had decreased remarkably at F-13 after 4 days (See Table 2).

IV-5. Oceanographic Conditions over the Continental Shelf Area and the Behavior of Sockeye Salmon

IV-5-1. Oceanographic Conditions over the Continental Shelf Area

Almost the whole area of the continental shelf including Bristol Bay in the eastern Bering Sea is covered with sea ice in winter and the melting period is about June.

Figs. IV-25~28 show the horizontal distribution of water temperature and salinity at 20 meter and the sea bottom, plotted from observation made during late June to early July in 1962~1967. The distributions were similar each year.

Figs. IV-29~32 show vertical sections of water temperature and salinity along various longitudes in Bristol Bay during late June to early July, 1965~1968. According to these figures, the water at 20 m over the continental shelf and in the Basin offshore of the shelf has warmed comparatively evenly, as the temperature has risen uniformly. The isotherms are oriented east-west, and the temperature grades from high in the south to low in the north (Fig. IV-25).

As to the oceanographic conditions near the sea bottom, a cold water mass with its center near St. Lawrence Island extends southeastwards like a wedge to Port Moller on the Alaska Peninsula (Fig. IV-27). The warming of the water near the northern shores in Bristol Bay is noticeable. As to the distribution of salinity at 20 meters and near the bottom, salinities near the edge of the continental shelf are comparatively high, 32.5‰ and 33.0‰ , respectively, and there is observed comparatively high salinity water ($>32.0\text{‰}$) flowing eastwards

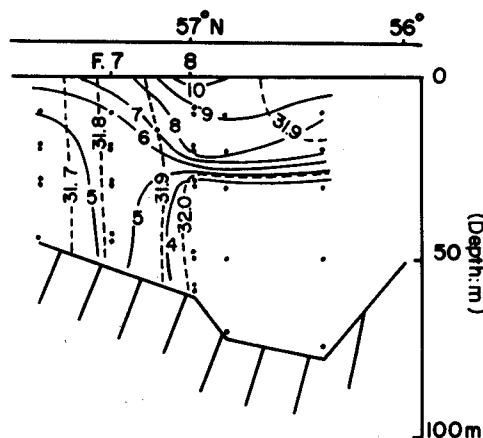

Fig. IV-31-A. Vertical sections of temperature (°C) and salinity (‰), and exploratory fishing stations along long. 162°W in late June, 1967.

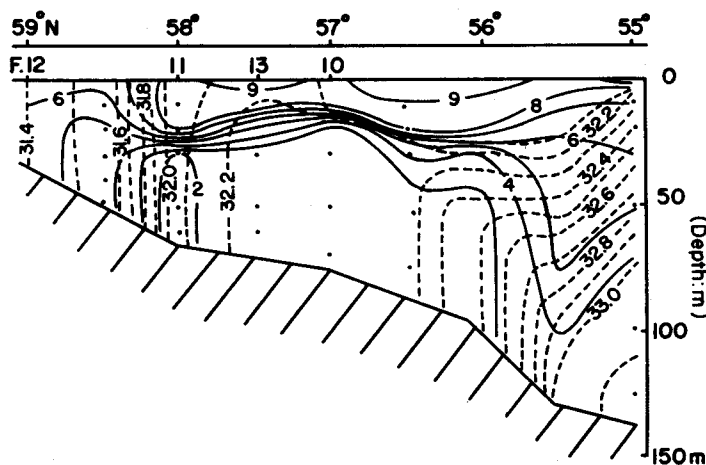

Fig. IV-31-B. Vertical sections of temperature (°C) and salinity (‰), and exploratory fishing stations along long. 166°W in late June, 1967.

into southern Bristol Bay and becoming diluted on reaching the coast of Alaska (Figs. IV-26, 28).

The vertical section of the distribution of water temperature along longitude 165°W in Bristol Bay shows higher temperature to the south and lower to the north. Near the sea bottom a remnant of a cold water mass was observed in the north-central part of the Bay, consequently relatively warmer water was observed in the northern coastal area.

As seen in Fig. IV-33 the coast of Bristol Bay is shallow, and the sea to the

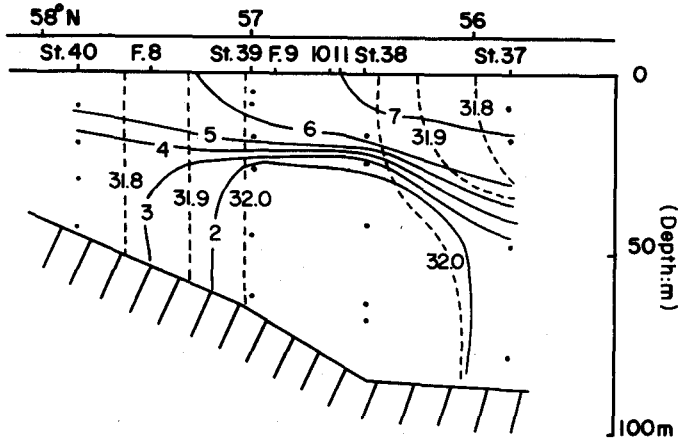

Fig. IV-32-A. Vertical sections of temperature ($^{\circ}\text{C}$) and salinity (‰), and exploratory fishing stations along long. 163°W in late June, 1968.

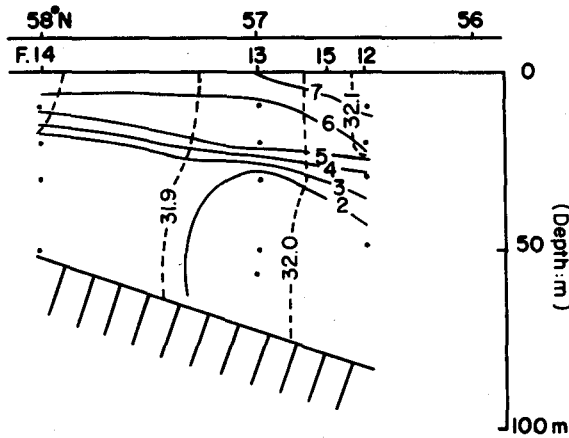

Fig. IV-32-B. Vertical sections of temperature ($^{\circ}\text{C}$) and salinity (‰), and exploratory fishing stations along long. 165°W in early July, 1968.

north is covered with ice in winter, but in the warming period the water temperature of the coastal water rises faster due to absorption of radiant heat and vigorous vertical mixing than that of the offshore waters.

To the south of the cold water mass the increase of temperature by heating from the surface can be observed, but the depth of penetration of the warming deepens gradually and in the more southern areas a distinct thermocline is not formed.

Salinity is almost uniform in the area of the cold water mass. This is probably largely due to mixing associated with the convection obtaining in

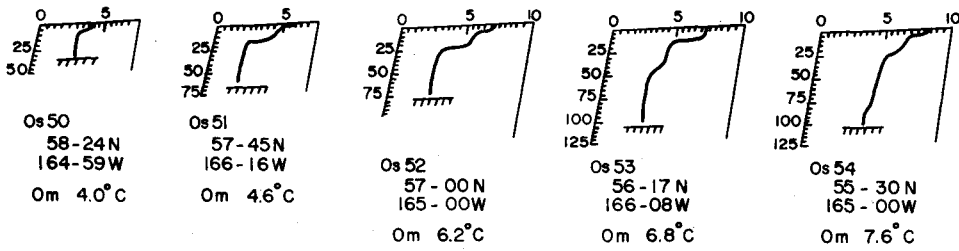

Fig. IV-33. B-T records along longitude 165°W in late June, 1965.

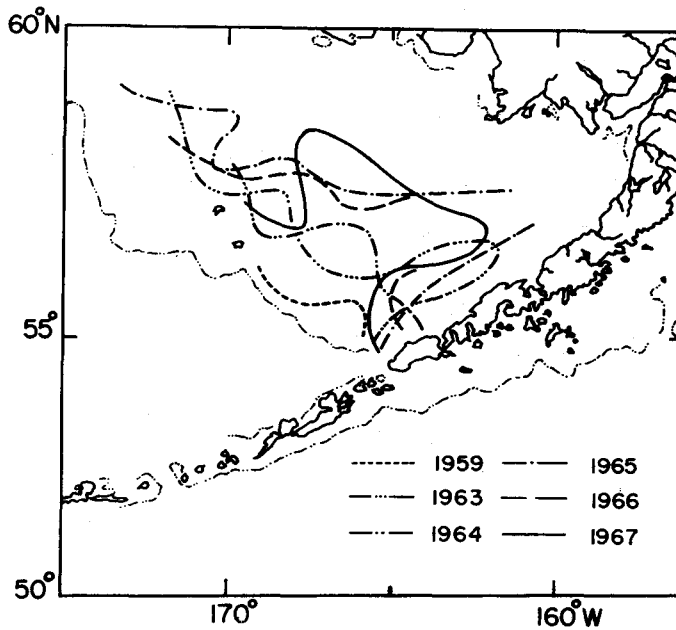

Fig. IV-34. Distribution of the 32.0‰ isohaline at 20 meters in outer Bristol Bay, June to early July in each year, 1959 and 1963-1967.

winter. This is considered to be the winter water of the continental shelf. In the south area where the salinities are $32.00 \pm 0.2\text{‰}$ the haloclines are included to the vertical.

A salinity value of 32.0‰ demarcates the mixed water flowing northward on the continental slope from the usual water on the shelf.

Thus, there is comparatively high salinity mixed water flowing eastward in the center of Bristol Bay, but the position of the flow varies from year to year (Fig. IV-34). In the northern part of the continental shelf area there is an area having low salinity and slight salinity gradients in the vertical (Fig. IV-35). This oceanographic structure offshore of Bristol Bay is considered to have important

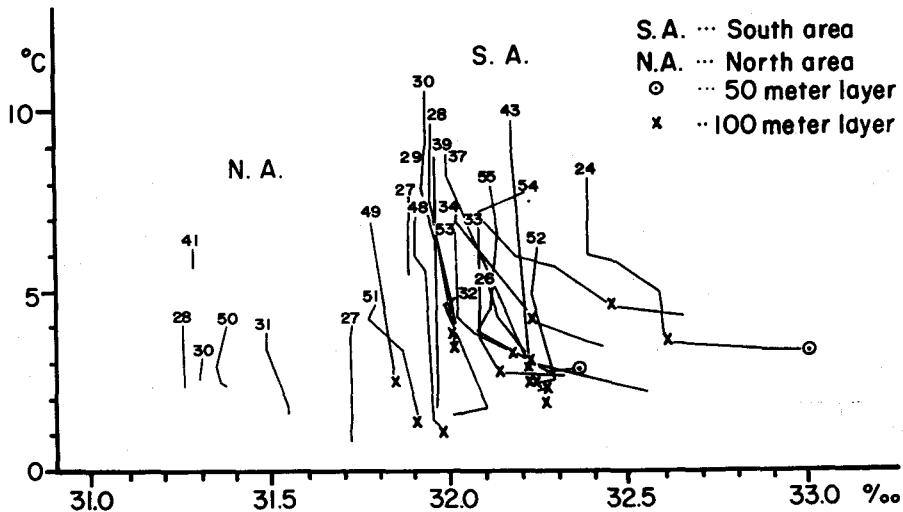

Fig. IV-35. T-S diagram from stations in Bristol Bay, 1965-1968.

Table IV-1. List of the numbers of salmon exploratory fishing stations along each longitude in Bristol Bay, 1965-1968.

Year	Date	Longitude (W.)	Latitude (N.)	Exploratory fishing station in number	No. of exploratory stations (F)
1965	Late June	165	58.5~54.8	4	12, 13, 14, 15
1966	"	168	59.0~54.9	3	11, 12, 13
1967	"	165	58.5~55.5	4	14, 15, 16, 17
1967	"	162	57.5~56.4	2	7, 8
1968	"	166	59.6~55.0	4	10, 11, 12, 13
1968	"	163	57.8~55.8	4	8, 9, 10, 11
1968	Early July	165	58.0~56.5	4	12, 13, 14, 15

influence on the migration route of *Oncorhynchus* coming in Bristol Bay (Fujii, 1968).

IV-5-2. Behavior of Sockeye Salmon in the Continental Shelf Area

The author has investigated the distribution of sockeye salmon from late June through early July every year, from 1965 to 1968, at 25 stations along each longitude on the continental shelf of the southeastern Bering Sea (Table IV-1).

The direction of gillnet sets was 150° as the usual standard, which is normal to the swimming direction of sockeye salmon.

The stations and the vertical distributions of water temperature and salinity at each longitude are shown in Figs. IV-29 (1965), -30 (1966), -31 (1967) and -32 (1968), and the species composition of *Oncorhynchus* in the catch from

Table IV-2. *Catch Per Unit Effort of salmon at exploratory fishing stations along longitude 165°W in late June, 1965.*

F	No. of gillnets used	Catch of fish						
		Total	Sockeye		Chum		Pink	
			Catch/tan	%	Catch/tan	%	Catch/tan	%
12	116	300	0.07	2.6	2.40	92.7	0.12	4.7
13	116	374	1.74	54.0	1.38	42.8	0.10	3.2
15	116	6290	53.86	99.3	0.34	0.6	0.02	0.1
14	116	163	1.19	84.7	0.19	13.5	0.03	1.8

Table IV-3-A. *Catch Per Unit Effort of salmon at exploratory fishing stations along longitude 168°W in late June, 1966.*

F	No. of gillnets used	Catch of fish						
		Total	Sockeye		Chum		Pink	
			Catch/tan	%	Catch/tan	%	Catch/tan	%
13	112	129	0.14	12.4	0.71	61.2	0.30	26.4
12	113	194	1.15	67.0	0.48	27.9	0.09	5.1
11	113	1188	10.31	98.1	0.19	1.7	0.02	0.2

Table IV-3-B. *Catch Per Unit Effort of salmon at exploratory fishing stations along longitude 165°W in late June, 1966.*

F	No. of gillnets used	Catch of fish						
		Total	Sockeye		Chum		Pink	
			Catch/tan	%	Catch/tan	%	Catch/tan	%
14	112	334	0.29	9.6	2.29	76.9	0.40	13.5
15	112	2065	18.35	99.5	0.08	0.4	0.01	0.1
16	58	624	10.27	95.5	0.04	3.7	0.09	0.8
17	109	100	0.76	83.0	0.15	16.0	0.01	1.0

exploratory fishing stations along each longitude is shown in Table IV-2 (1965), -3 (1966), -4 (1967) and -5 (1968). As seen in the Tables, predominant absolute and relative numbers of sockeye salmon are limited to specific stations through years and longitudes. The stations where sockeye salmon were predominant each year were;

1965.....F 15 (165°W)

1966.....F 11 (168°W), F 15, 16 (165°W)

1967.....F 8 (162°W), F 10, 13 (166°W)

1968.....F 11, 10 (163°W), F 15, 12 (165°W)

Comparing the results, the predominant distribution is restricted to the surface layer of mixed water (comparatively high-temperature and high-salinity)

Table IV-4-A. *Catch Per Unit Effort of salmon at exploratory fishing stations along longitude 162°W in late June, 1967.*

F	No. of gillnets used	Catch of fish						
		Total	Sockeye		Chum		Pink	
			Catch/tan	%	Catch/tan	%	Catch/tan	%
7	123	395	1.22	37.9	1.93	60.3	0.06	1.8
8	123	3017	20.56	83.8	3.86	15.8	0.11	0.4

Table IV-4-B. *Catch Per Unit Effort of salmon at exploratory fishing stations along longitude 166°W in late June, 1967.*

F	No. of gillnets used	Catch of fish						
		Total	Sockeye		Chum		Pink	
			Catch/tan	%	Catch/tan	%	Catch/tan	%
12	101	208	1.50	73.1	0.37	17.8	0.19	9.1
11	101	401	2.05	51.6	1.80	45.4	0.12	3.1
13	101	626	5.50	88.7	0.66	10.7	0.04	0.6
10	93	1303	13.39	95.5	0.58	4.2	0.04	0.3

Table IV-5-A. *Catch Per Unit Effort of salmon at exploratory fishing stations along longitude 163°W in late June, 1968.*

F	No. of gillnets used	Catch of fish						
		Total	Sockeye		Chum		Pink	
			Catch/tan	%	Catch/tan	%	Catch/tan	%
8	137	439	0.96	30.1	2.07	64.4	0.18	5.5
9	137	245	1.23	68.6	0.47	26.1	0.09	5.3
10	136	1001	6.12	83.2	1.10	15.1	0.14	1.7
11	135	998	6.53	88.3	0.81	10.9	0.06	0.8

Table IV-5-B. *Catch Per Unit Effort of salmon at exploratory fishing stations along longitude 165°W in late June, 1968.*

F	No. of gillnets used	Catch of fish						
		Total	Sockeye		Chum		Pink	
			Catch/tan	%	Catch/tan	%	Catch/tan	%
14	132	305	0.07	33.4	0.46	20.0	1.08	44.6
13	132	94	0.39	55.3	0.27	38.8	0.05	6.4
15	131	645	2.98	60.6	1.27	25.9	0.66	13.5
12	133	445	2.34	69.9	0.83	24.7	0.18	5.4

influenced by high seas water flowing from west to east through the central region of Bristol Bay. To the north of the mixed water, the coastal water area (low temperature and low-salinity) toward Alaska proper, or to the south of the mixed water area, the coastal water area (high-temperature and low salinity) toward the Alaska Peninsula, sockeye salmon were scarce.

That the main route of homing migration of sockeye salmon in the continental shelf area is restricted to the mixed water area is an important conclusion.

V. General Discussion

V-1. Relation between the Entering of Sockeye Salmon into the Bering Sea Passing through Channels or Passes and the Oceanographic Conditions

In the case of the entering of sockeye salmon into the Bering Sea from the North Pacific Ocean, specific oceanographic environments restraining free entry are formed in the channels or passes between the Aleutian Islands.

The oceanographic environment inhibiting the fish is a vertically mixed sea water having low temperature and high salinity, which is formed in the upper layer in the channels or passes. Only when this vertically mixed water disappears can the sockeye salmon schools enter the Bering Sea.

Fig. IV-6-B shows the vertical section of water temperature, salinity and density (σ_t) near Amchitka Pass (179°W) soon after sockeye salmon passed through the Pass, June 12~14, 1965. According to the Figure, the fact that the surface layer (less than 10~20 meters depth) reached through the pass into the Bering Sea to near a point (St. 27) where a reversed layer of the salinity was formed suggests a rapid northward current. Consequently, the vertically mixed water which is formed normally in the upper layer, with low temperature and high salinity had disappeared, and the density of the upper layer water to both the south and north of the Aleutian Islands had become almost equal. This is the condition when sockeye salmon readily pass through the channels or passes.

Fig. V-1 shows the exploratory fishing stations of the Kizan Maru fleet (called KI-fleet) to the south of the Aleutian Islands, of the Kyokuzan Maru fleet exploratory vessel (called K. fleet exploratory vessel) and the *Oshoro Maru* to the north of the Islands, and the routes of cyclones from late May to middle June, 1965.

The catches of sockeye salmon and the water temperature in the surface layer observed by the *Oshoro Maru*, K. fleet exploratory vessel and KI. fleet to the north and south of the Aleutian Islands from late May to middle June, 1965, are shown in Fig. V-2.

The catch by KI. fleet was good, more than 4.7 per tan, on June 2, but decreased to less than 2 per tan after June 4. On the other hand, the catch by K. fleet

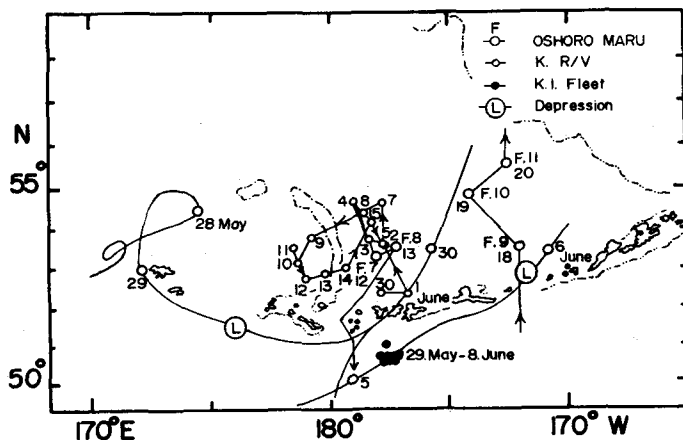

Fig. V-1. The exploratory fishing stations of the *Oshoro Maru*, K. fleet exploratory vessel and K.I. fleet in the Aleutian area, and the route of cyclones, from late May to middle June, 1965.

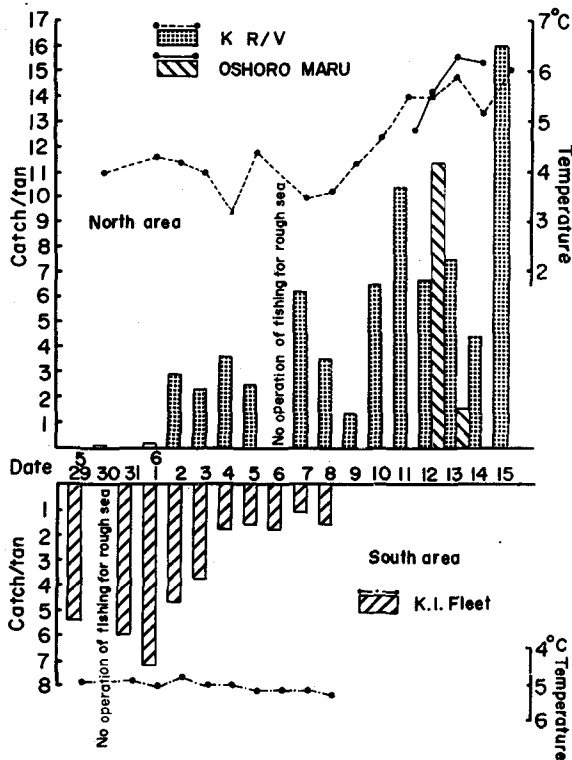

Fig. V-2. Catches of sockeye salmon and the sea surface temperature observed by the *Oshoro Maru*, K. fleet exploratory vessel and K.I. fleet and south of the Aleutian Islands from late May to middle June, 1965.

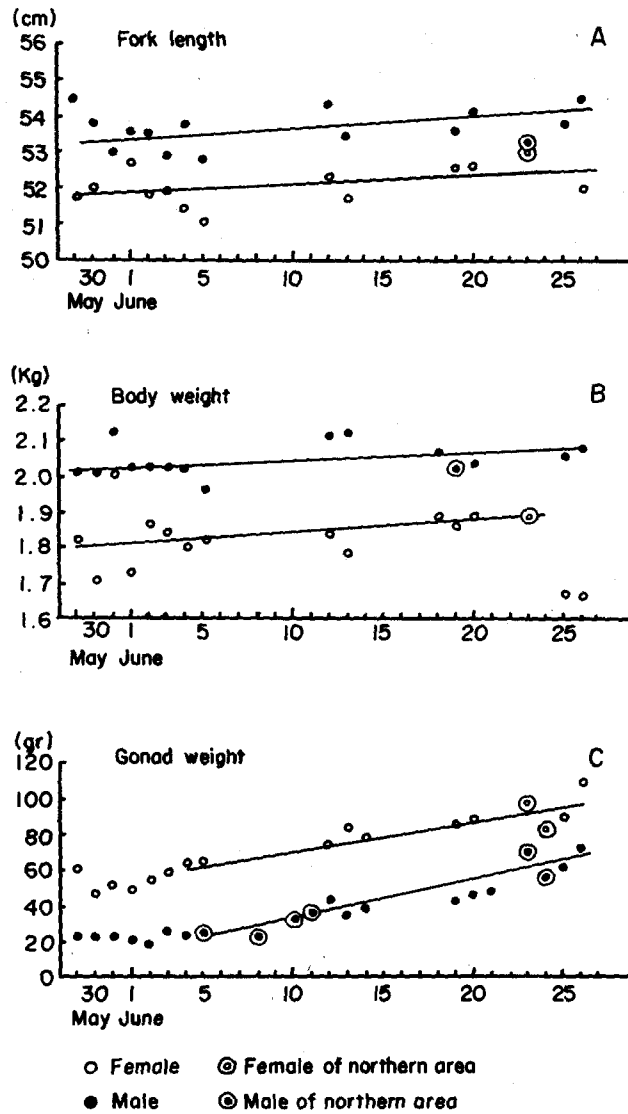

Fig. V-3. Changes of mean fork length (A), body weight (B) and gonad weight (C) with time of the 5, age group of western Alaska sockeye salmon during migration from the southern area of Aleutian Islands to Bristol Bay in early summer, 1965.

exploratory vessel in the Bering Sea increased rapidly after June 2. The catch by the *Oshoro Maru* was very good, 11.4 sockeye salmon per tan at St. 27 (F 7), which is considered to have been at the end of the northward current on June 12 (See Table 1).

The fact that there was a good catch of sockeye salmon to the south of the

Aleutian Islands in late May which decreased in early June, and at the same time the catch increased to the north, suggests the time the sockeye salmon entered into the Bering Sea through the channels or passes.

The fish of the 5₃ age group are considered to have been from the same school (cf. Fig. V-3, which shows a time series of changes of mean fork length, body weight and gonad weight) during migration from the south side area of the Aleutian Islands to Bristol Bay in early summer, 1965. The water temperature of the surface layer to the south of the Islands was about 5°C, with little variation, but an increase from 4°C to 6°C was observed in the Bering Sea. The increase water temperature correlates with the behavior of the fish school. Thus, there might have been a movement of a large water mass suddenly into the Bering Sea for some reason, with could have been brought about by spring tides or a rapid meteorological change. June 1 of that year was the first or second of the lunar month and the time when sockeye salmon passed into the Bering Sea was during the previous spring tidal period. Over these areas two cyclones passed in late May and early June, from the southwest to the northeast, counterclockwisely.

On the approach of a depression strong west or northwest drift currents could occur in the area of the Aleutian Islands. In the northern North Pacific Ocean, strong winds occur near the outer edges rather than in the centers of depressions, and thus the water area over which wind drifts can form is widely.

In the Alaskan Stream, which flows westwards along the south side of the Aleutian Islands, the drift current is considered to be formed in the southerly or easterly area of the eastern front of the depression. This strong drift current accelerates the northward current of North Pacific Ocean water (mainly composed of Alaskan Stream water), and a strong northward water movement would occur in the channels or passes between the Islands. By this oceanographic change, abnormal northward currents could occur in certain passes (e.g. in Amchitka Pass), and the northward movement of water would bring the sockeye salmon schools into the Bering Sea (Fujii, 1969, 1970).

Therefore, even if the movement of water masses in channels or passes is rapid, unless water from the south suddenly enters into the Bering Sea, the entering of the majority of sockeye salmon does not occur. If there is no convenient channel or pass by which to enter, the sockeye salmon south of the Aleutian Islands move westward without hesitation in May through June (Hartt, 1962, 1966). A major problem remains, namely, to ascertain those passes in which the most favorable oceanographic conditions obtain. This problem cannot be adequately solved from the oceanographic data available and further investigation is required.

V-2. Relation between the Northward Distribution of Western Alaska Sockeye Salmon in the Basin Area and the Oceanographic Conditions

Sockeye salmon have been observed in the Bering Sea even in winter (French and Mason, 1964, French, 1965), but in low concentration (0.7 per tan near 180°, 1.3 per tan at 175°E). They are mostly fish which wintered in the ocean (near 180° the percentage of the fish wintered for 3 winters was 57%, that for 2 winters was 35%, and at 175°E that for 3 winter was 86%, that for 2 winters 10%) (See Tables 3, 4). The density-age composition of sockeye salmon in the Bering Sea in winter resembles those of the fish in the northern area of the Bering Sea as described later, but an identification of the school and groups of sockeye salmon has not been carried out.

Figures IV-19, -A, -B, -C show the distribution of the salinity in the dichothermal layer in June of 1965.

The migratory routes are in the low salinity area which extends westward in the neighborhood of 57°N, and in the southerly area of low salinity. The north border of the low salinity area, bounded by the isohaline of 33.1~33.2‰, is the north side of the migratory route. There is a significant difference in fork length of 5₃ age fish, which was the predominant school of the western Alaska sockeye salmon, between the southern and northern sea areas (Table V-9). This is perhaps due to environmental differences. Even in the years (1966, 1967) when larger schools of sockeye salmon were not caught in the eastern Basin area, much larger catches were obtained in the area south of the boundary isohaline than the northern area (See Table 5).

In the comparatively high salinity (33.2~33.0‰) sea area which lies south of the low salinity area in the Basin, sockeye salmon move with comparatively high migration speeds (at least 30~40 miles/day), as if a tempting to escape.

The low salinity area is an extension of the mixed water from the continental slope, of which the density (σ_t) shows a minimum in the Basin area. If sockeye salmon migrate northwards through the low salinity area, the fish must enter with difficulty into a low temperature and high salinity water mass (Fig. IV-17). In fact the northern area, where the density (σ_t) is greater, prevents the northward migration of the fish. Therefore, the sockeye salmon move eastwards through the lower salinity area. The north side of the low salinity area corresponds to the north limit of the migration of the western Alaska sockeye salmon, as determined by Margolis et al. (1966) from liberation experiments of tagged fish or parasitological studies (Fig. V-4). The position of the low salinity area varies year to year (Fig. IV-16), thus changing the distribution area of the western Alaska sockeye salmon in the Bering Sea, and this area has significance for the formation of good

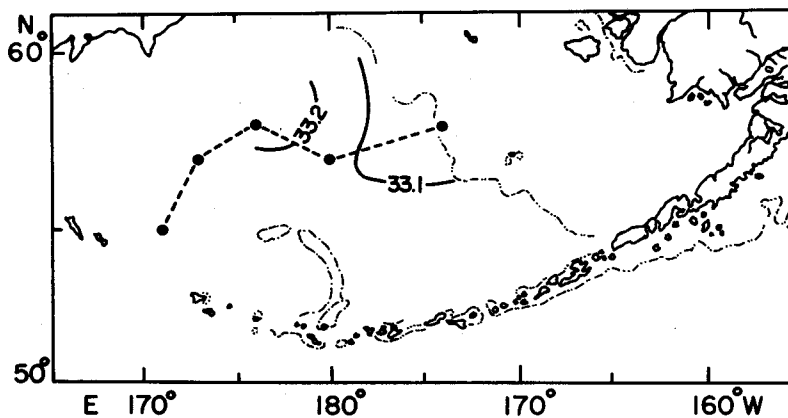

Fig. V-4. Relation between the catch of western Alaska sockeye salmon in the lower salinity area and the north limit of their distribution in the basin of the Bering Sea.

fishing grounds for sockeye salmon in the Bering Sea.

V-3. Relation between the Distribution and the Migration of Sockeye Salmon in the Continental Slope Area and the Oceanographic Conditions

The continental slope sea area is a mixed water area having large horizontal gradients of salinity; where it borders on the Basin area it has a salinity of 33.0‰, and where it borders on the continental shelf coastal water a salinity of 32.0‰.

The western Alaska sockeye salmon during homing migration might be prevented from moving from the Basin area into the continental shelf area probably because of a necessary osmotic adjustment and must remain in the mixed water area for a time (Figs. IV-21, 22).

The distribution of the sockeye salmon is generally dense in the area south of the Pribilof Islands, and is thin in the north area through June.

The oceanographic structure of the area in which a varying distribution of density is observed, has differences of water temperature and salinity in the surface layer, as seen in Fig. V-5. That is, in the areas where the distribution of sockeye salmon is dense there is formed a halocline and a distinct thermocline between 20~50 meters depth, above which a temperature increase and salinity decrease are observed. In those areas where there is significant vertical temperature and salinity structure in the near surface layer, the density of salmon distribution is thin. These facts are interpreted in this way: Alaskan Stream water flows northwards into the southern part of the mixed water area from south of the Aleutian Islands in June, but the surface layer of mixed water has increased in temperature from winter. The sockeye salmon are observed to become dense in early summer in the sea area where the northward movement of a part of Alaskan

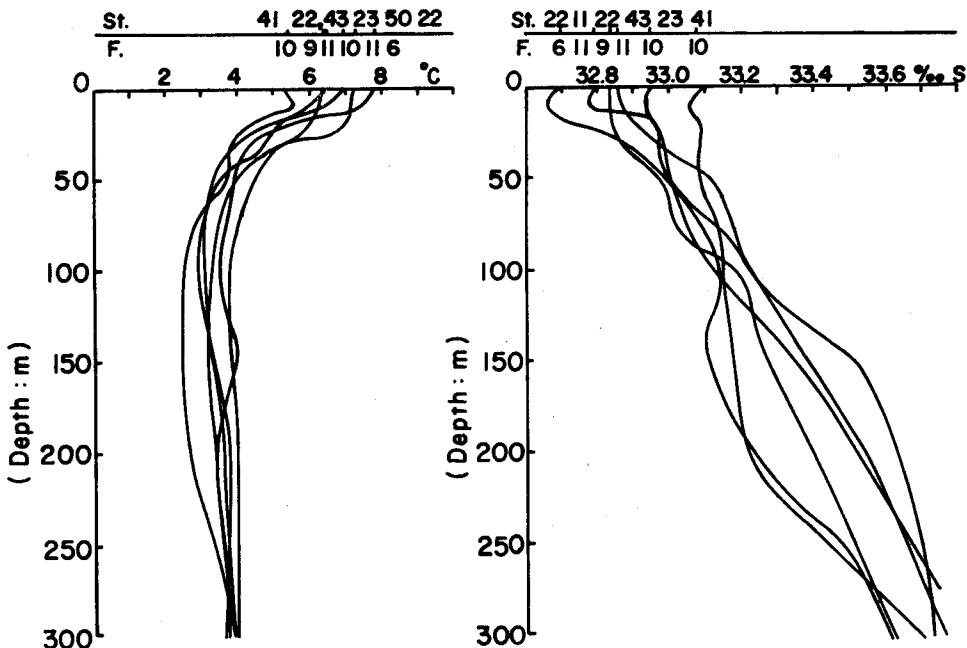

Fig. V-5-A. Water structures at fishing stations with good catch of sockeye salmon in continental slope area of the eastern Bering Sea.

Stream occurs concurrent with the rising of the temperature of the surface water.

According to the distribution investigation (Fig. IV-24) the catch of sockeye salmon at the same position (54.9°N, 169.4°W) in the area south of the Pribilof Islands in late June, 1964, increased from day to day (from F 9 to F 11), but decreased rapidly at F 13 (See Table 2). The changes in the oceanographic structure during the same time at the same position (54.9°N, 169.4°W) on the continental slope are shown in Fig. V-6.

The water mass having low temperature and low salinity has flowed into the upper layer of the south area. The movement of water into the mixed water area is considered to have a relation to the movement of sockeye salmon. The cause of the movement of water mass is the passing of depression (1,000 mb) eastwards on about June 24 when a dense distribution of sockeye salmon was observed. The depression caused a wind-drift to form near the center of the depression, which accelerated the movement of the water mass into the upper layer of the south area.

V-4. The Distribution of Western Alaska Sockeye Salmon in the Continental Shelf Area and the Oceanographic Conditions

In the mixed water mass having comparatively high temperature and high

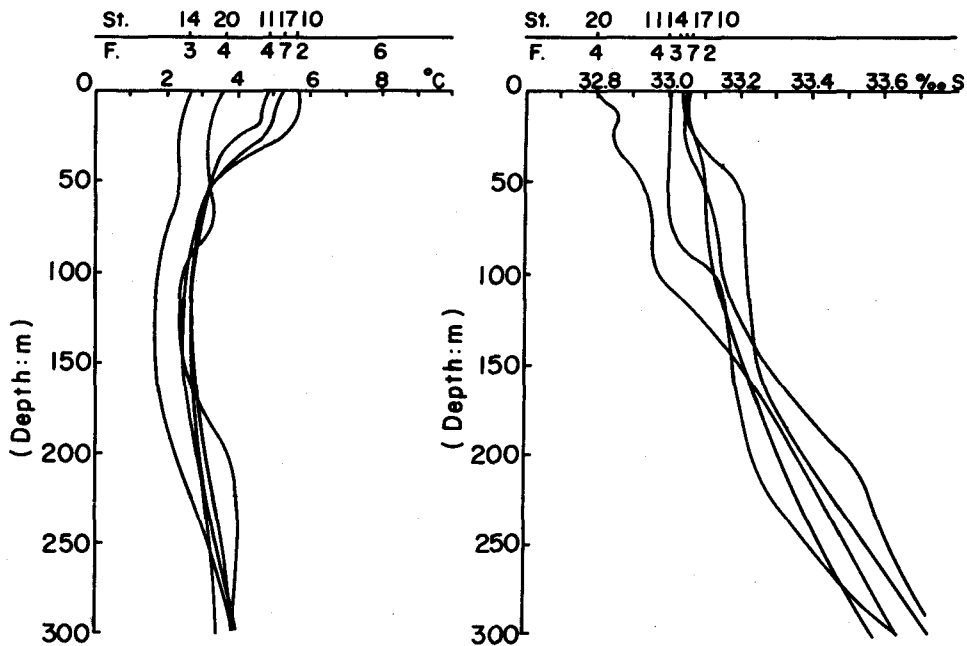

Fig. V-5-B. Water structures at fishing stations with poor catch of sockeye salmon in continental slope area of the eastern Bering Sea.

salinity (above 32.0‰), which flows eastwards through the center of Bristol Bay (near 56~57°N), the distribution of sockeye salmon is observed to be dense, especially in the inner end of the Bay having $32.0 \pm 0.2\text{‰}$ (Fig. V-7). This mixed water consists mainly of Alaskan Stream water which flowed into the Bering Sea through eastern channels or passes between the Aleutian Islands.

The vertically isohaline water, with comparatively low temperatures and low salinities, is coastal water which has wintered in the continental shelf area (Fig. II-14). This coastal water has only slight gradients of salinity decreasing toward the coast. Considering these oceanographic conditions,

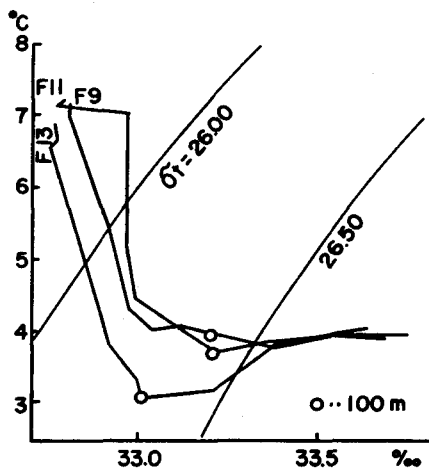

Fig. V-6. T-S diagrams at the same position (54.9°N, 169.4°W) on the continental slope of the southeastern Bering Sea, 1964.

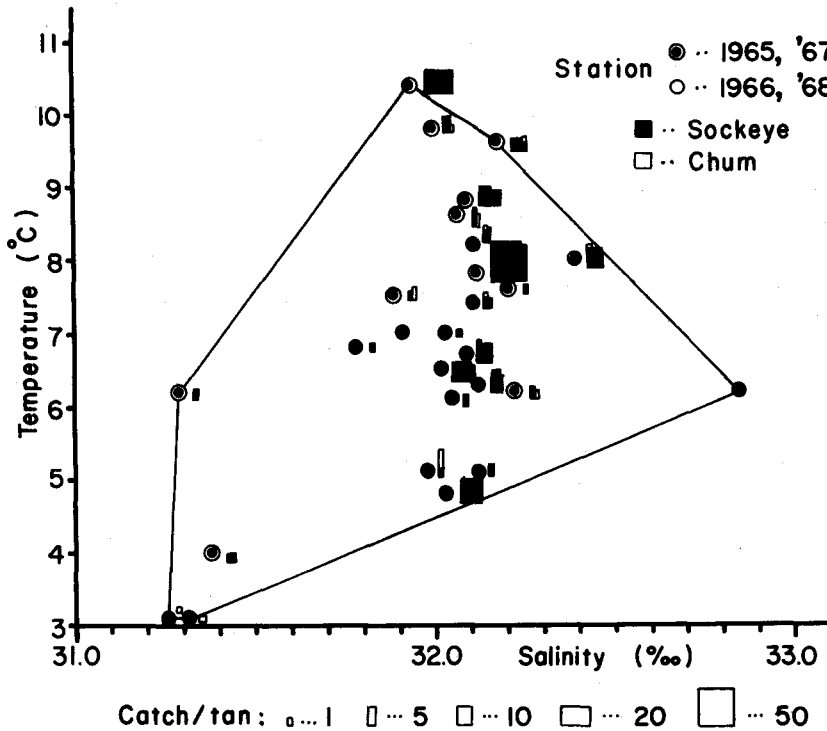

Fig. V-7. Relation between catch of sockeye salmon and temperature and salinity in the Bristol Bay area.

the sockeye salmon which wintered in the North Pacific Ocean enter the mixed water area after entering the Bering Sea. The dense distribution in this mixed water area is due to the fact that the density (σ_t) has been lowered in the upper layer by the rising of the water temperature. The counterclockwise currents in Bristol Bay have brought this mixed water into the inner part of the Bay. This eastward movement of mixed water is the important route of the migration of the western Alaska sockeye salmon.

In the vertically isohaline area the distribution of sockeye salmon is very thin, but that of chum salmon is denser than in the mixed water area, although that in the western sea area is thin (Table IV-1 ~5). Along the northern boundary where the mixed water area borders on the vertically isohaline area, the distribution of sockeye salmon and chum salmon are nearly equal (1965...F 13, 1967...F 11), but the absolute concentration of the former is less than at the end of the mixed water area. The fact that the fork length is larger at the boundary than in the mixed water area has important significance for the distribution of the western Alaska sockeye salmon in offshore Bristol Bay.

Table V-1. *Age composition of mature sockeye salmon in Bristol Bay. (Japanese Fisheries Agency, 1969)*

Year	Total number of homing sockeye (million)	Age composition (%)				
		4 ₂	5 ₂	5 ₃	6 ₃	other
1965	59.7	2	6	88	3	1
1966	18.8	11	19	17	55	1
1967	11.6	11	13	55	20	2
1968	9.4	37	20	26	13	4

V-5. Migrating Routes of the Western Alaska Sockeye Salmon Classified by Mother Rivers

The percentage of the predominant age group in the age composition of matured sockeye salmon in the eastern Part of the Bering Sea, east of 177°E in June through July, is almost the same as that of the fish coming to Bristol Bay in the same year (Table V-1). From the above investigation and those by Manzer (1965) and Margolis (1967), the sockeye salmon found in the eastern area of the central Bering Sea are considered to be from western Alaska.

The western Alaska sockeye salmon are distributed abundantly in the southern area, including the low salinity area at 57°N in the Basin, and the mixed water area flowing eastwards at 56 ~ 57°N and its southern area over the continental shelf. The age groups of sockeye salmon having high frequencies of appearance in the south and north sides of the mixed water area, in which different distribution are observed, are 5₃, 6₃, 5₂ and 4₂ year fish (Table V-2). From 1965 to 1968, the 5₃ year and 6₃ year sockeye salmon were the predominant groups alternate years. In the year (1965, 1967) when 5₃ year sockeye salmon occupied the predominant group in both the south and the north areas of mixed water, the 5₃ year fish were the most abundantly caught in the both areas.

In the year (1966) when 6₃ year sockeye salmon were the predominant group, the 6₃ year fish were the most abundantly caught in both areas, and in 1968, with the same conditions, the same age fish were the most abundantly caught only in the north area. In the south area that year where salmon concentrations were dense the catch of 5₃, 5₂ and 4₂ year fish as well as 6₃ year fish was higher. In Bristol Bay groups of sockeye salmon which had wintered for tow years (5₃, 4₂) were generally coming back abundantly (66%), but in 1966 the group of 6₃ year fish had wintered for three years, are unusual occurrence (Fisheries Agency, Ministry of Agriculture, Japanese Government, 1969). Therefore 6₃ year fish were caught in exceptionally great quantities in the southern part of the mixed water area offshore. It is generally observed that fish which have passed comparatively few winters in the ocean are distributed abundantly in the south sea area and fish which have passed more winters in the sea are distributed in the north sea area. The

Table V-2. Age composition comparison between the sockeye salmon caught each year,

Year	Area	N	Age	
			4 ₂	5 ₂
1965	North	146	2.05 (0.70-5.87)	10.27 (6.33-16.26)
	South	328	0.91 (0.31-2.65)	3.05 (1.66-5.52)
1966	North	158	0 (0-2.37)	8.23 (4.87-13.57)
	South	1088	3.95 (2.95-5.28)	11.76 (9.98-13.82)
1967	North	453	0.44 (0.14-2.70)	2.65 (1.52-4.37)
	South	1138	1.76 (1014-2.70)	2.11 (1.42-3.12)
1968	North	114	2.63 (0.90-7.45)	13.16 (8.14-20.58)
	South	1372	19.46 (17.45-21.64)	15.89 (14.05-17.92)

Table V-3. Age composition of the Bristol sockeye salmon classified by the area. (Taguchi, 1966)

District	Age composition (%)				Notice
	4 ₂	5 ₂	5 ₃	6 ₃	
Nushagak	38.7	41.4	9.9	8.6	1953-1955
Naknek	5.2	15.0	15.2	58.1	1950-1955
Kvichak	15.2	18.9	23.6	38.9	1953-1955
Ugashik	2.3	9.4	41.9	37.5	1950-1955
Egegik	2.9	4.6	45.9	40.6	1952-1955

Table V-4. Comparison of age composition between fast developing growth group and slow developing growth group by mother stream (%). (Hanamura, 1966)

		Naknek-Kvichak Group	Ugashik Group	Egegik Group	Nushagak Group	Eastern Kamchatka Group	Western Kamchatka Group
Year class of fast developing group	4 ₂	55	55	35	70	5	10 ¹⁾
	5 ₂	30	25	40	25	55	40
	5 ₃	10	15	15	3	10	20
	6 ₃	5	5	10	2	20	20
Year class of slow developing group	4 ₂	5	5	5	25	10	5 ²⁾
	5 ₂	10	10	5	60	30	15
	5 ₃	65	60	60	10	15	45
	6 ₃	20	25	25	5	40	30

Note: 1)even numbered year 2)odd numbered year

in the southern area and northern area of the eastern Bering Sea, June to July 1965-1968.

composition (%)			x ²	df	p
5 _s	6 _s	other			
67.12 (59.15-74.22)	17.12 (11.88-24.06)	3.42 (1.47-7.77)	28.239	4	<0.005
84.45 (80.13-87.98)	10.37 (7.51-14.14)	1.22 (0.48-3.09)			
13.29 (8.86-19.46)	75.32 (68.04-81.39)	3.16 (1.36-7.19)	6.433	3	0.100-0.050
17.74 (15.58-20.12)	65.26 (62.36-68.05)	1.29 (0.77-2.15)			
52.76 (48.16-57.31)	39.74 (35.34-44.30)	4.42 (2.88-6.72)	26.003	4	<0.005
63.88 (61.07-66.60)	27.77 (25.25-30.44)	4.48 (3.45-5.84)			
20.18 (13.84-28.46)	57.89 (48.72-66.55)	6.14 (3.01-12.13)	52.860	4	<0.005
30.68 (28.30-33.18)	32.51 (30.08-35.03)	1.46 (0.95-2.24)			

Table V-5. *Age composition of sockeye salmon caught at exploratory fishing stations along longitude 165°W in late June, 1965.*

Operation point	Area	N	Age composition (%)				
			4 ₂	5 ₂	5 _s	6 _s	other
F 12	○	7	0	14.3	85.7	0	0
F 13	○	29	3.4	13.8	72.4	10.3	0
F 15	●	105	0	5.7	74.0	25.7	1.8
F 14	●	27	0	7.4	85.2	7.4	0

○ Northern area ● Southern area

density of the distribution is high in the southern area and low in the northern area.

Taguchi (1966) determined age composition of Bristol Bay salmon in different areas in each year 1950 through 1955, and the results are shown in Table V-3. Hanamura (1966) has studied some characteristics of Bristol sockeye salmon with a view to division into subclasses, and found that there is a difference in age composition owing to the rate of growth even though they are grouped in the same locality, and they can be classified as rapid and slow developing groups (Table V-4).

The age composition is shown in Tables V-5~8 from the results (Figs. IV-29~32) of investigations in the continental shelf area in 1965~1968 by the *Oshoro Maru*.

The author has assumed that the main homing groups consist of the following

Table V-6-A. Age composition of sockeye salmon caught at exploratory fishing stations along longitude 168°W in middle June, 1966.

Operation point	Area	N	Age composition (%)				
			4 ₂	5 ₂	5 ₃	6 ₃	other
F 13	○	17	0	5.9	11.7	76.5	5.9
F 12	●	121	0.8	0	4.0	92.6	1.8
F 11	●	97	19.6	22.7	20.6	37.1	0

○...Northern area ●...Southern area

Table V-6-B. Age composition of sockeye salmon caught at exploratory fishing stations along longitude 165°W in late June, 1966.

Oparetion point	Area	N	Age composition (%)				
			4 ₂	5 ₂	5 ₃	6 ₃	other
F 14	○	35	0	5.7	8.6	82.8	0
F 15	○	83	0	6.0	19.3	71.1	3.6
F 16	●	83	8.4	32.5	19.3	39.8	0
F 17	●	69	10.2	13.0	29.0	47.8	0

○...Northern area ●...Southern area

Table V-7-A. Age composition of sockeye salmon caught at exploratory fishing stations along longitude 162°W in late June, 1967.

Operation point	Area	N	Age composition (%)				
			4 ₂	5 ₂	5 ₃	6 ₃	other
F 7	○	109	0.9	5.6	36.8	39.4	7.3
F 8	●	160	1.3	1.3	59.3	33.7	4.4

○...Northern area ●...Southern area

Table V-7-B. Age composition of sockeye salmon caught at exploratory fishing stations along longitude 166°W in late June, 1967.

Operation point	Area	N	Age composition (%)				
			4 ₂	5 ₂	5 ₃	6 ₃	other
F 12	○	154	0	1.9	50.0	46.8	0.6
F 11	○	162	0.1	1.2	57.4	35.8	0
F 13	●	208	0.5	0	60.1	35.1	1.4
F 10	●	137	0	1.5	63.5	32.8	0

○...Northern area ●...Southern area

local fish schools (cf. Hanamura 1966; Taguchi, 1966):

1965.....Naknek and Kvichak groups: slow growth.

1966.....Naknek group: if the amount of 6₃ is replaced by that of 5₃, this group is considered to be Naknek and Kvichak groups of slow

Table V-8-A. *Age composition of sockeye salmon caught at exploratory fishing stations along longitude 163°W in late June, 1968.*

Operation point	Area	N	Age composition (%)				
			4 ₂	5 ₂	5 ₃	6 ₃	other
F 8	○	96	2.1	8.3	25.0	62.5	2.0
F 9	●	141	14.2	17.5	22.4	44.1	0
F 10	●	160	19.4	17.5	30.0	33.1	0
F 11	●	160	25.0	16.9	25.6	30.6	1.3

○...Northern area ●...Southern area

Table V-8-B. *Age composition of sockeye salmon caught at exploratory fishing stations along longitude 165°W in early July, 1968.*

Operation point	Area	N	Age composition (%)				
			4 ₂	5 ₂	5 ₃	6 ₃	other
F 14	○	65	4.6	10.8	30.8	43.1	10.7
F 13	●	42	7.1	11.9	31.0	50.0	0
F 15	●	122	15.6	18.9	42.6	18.9	4.0
F 12	●	138	18.1	16.7	38.4	26.1	0.7

○...Northern area ●...Southern Area

growth.

1967.....Egegik group and Ugashik group: slow growth.

1968.....A mixed group of Naknek, Kvichak, Egegik and Ugashik, especially in the southern area Ugashik, Naknek or Kvichak, of slow growth.

Thus the southern local groups of Naknek, Kvichak, Egegik and Ugasik, which are said to be of slow growth by Hanamura, were observed in the continental shelf area offshore of Bristol Bay during late June to early July. In the years when sockeye salmon are abundant the predominant local groups are found offshore, but in the years when small numbers of fish are present the local groups cannot be distinguished from each other. The dense schools of sockeye salmon found during late June near the end of the mixed water area offshore of Bristol Bay are the main object of fishing when they approach the coast during early to middle July, at the height of fishing activity in the bay. In this period the groups growing rapidly and the Nushagak group cannot be distinguished.

V-6. The Distribution of Western Alaska Sockeye Salmon and Fork Length

Tables V-9 and 10 show the mean fork lengths of 5₃ age sockeye salmon in 1965 and 6₃ age fish in 1966, respectively, in both the southern and the northern sea areas.

Table V-9. Comparison of mean fork length of the 5₃ age sockeye salmon between the north area and the south area of the eastern continental shelf in the eastern Bering Sea, 1965.

Sex	Area	N	Variance	Mean			
Male	B.P.	North	61	3.383	F=1.570	55.869	t'=6.477
		South	110	5.310	df: 109, 60 0.05>P>0.025	53.782	0.1% level 3.427 0.001>P
	C.S.	North	18	5.242	F=1.541	56.222	t=4.236
		South	22	3.402	df: 17, 21 0.25>P>0.10	53.455	df=38 0.001>P
	B.P. and C.S.	North	79	3.767	F=1.321	55.949	t'=7.707
		South	132	4.978	df: 131, 78 0.025>P>0.01	53.727	0.1% level 3.365 0.001>P
Female	B.P.	North	9	6.000	F=1.872	55.667	t'=5.486
		South	69	3.205	df: 8, 68 0.01>P>0.05	52.029	df=76 0.001>P
	C.S.	North	8	6.286	F=1.006	54.000	t=2.756
		South	25	6.250	df: 7, 24 0.50>P>0.25	51.200	df=31 0.01>P>0.005
	B.P. and C.S.	North	17	6.485	F=1.585	54.882	t=5.531
		South	94	4.092	df: 16, 93 0.10>P>0.05	51.809	df=109 0.001>P

B.P..... Basin portion C.S..... Continental shelf

The larger size fish of 5₃ age were found in the northern sea area where sockeye salmon were thinly distributed, and there was a significant difference in size between the 5₃ age fishes on the north and south sides of the mixed water area. This fact suggests different living conditions due to different environmental factors (Kubo, 1957). The fact that there is no significant difference between 6₃ age fish groups caught in the two areas is considered to be due to the slower growth of 6₃ as compared with 5₃. The fact that there is dense distribution of sockeye salmon in the southern sea area in the eastern Bering Sea testifies that western Alaska sockeye salmon avoid the north sea area, and that 6₃ age fish are well adapted to the environment.

V-7. Relation between the Migrating Route of the Western Alaska Sockeye Salmon into Bristol Bay from the South Side of the Aleutian Islands and the Water Temperature and Salinity

Fig. V-8 shows T-S diagrams from each sea area having catches greater than 1 fish per tan. According to the Fig. V-8, there is an abundant distribution observed in the south side area of the central Aleutian Islands (west of 175°W), where temperatures are 5°±0.3°C and salinities 32.6~33.2‰ in late May.

Table V-10. Comparison of mean fork length of the 6₃ age sockeye salmon between the north area and the south area of the eastern continental shelf in the Bering Sea, 1966.

Sex	Area	N	Variance	Mean	
Male	B.P.	North	8	3.553 F=3.687 df: 157, 7	62.125 t'=0.756
		South	158	13.099 0.05>P>0.025	61.576 0.50>P>0.40
	C.S.	North	37	16.466 F=3.277 df: 36, 64	60.919 t'=1.815
		South	65	5.024 0.005>P	62.231 0.10>P>0.05
	B.P. and C.S.	North	45	14.255 F=1.320 df: 44, 222	61.133 t=1.151
		South	223	10.801 0.10>P>0.05	61.767 df=266 0.40>P>0.20
Female	B.P.	North	10	1.211 F=4.405 df: 277, 9	59.900 t'=1.990
		South	278	5.335 0.01>P>0.005	59.151 0.10>P>0.05
	C.S.	North	58	6.016 F=1.147 df: 57, 115	59.862 t=0.936
		South	116	5.243 0.50>P>0.25	52.509 df=172 0.40>P>0.20
	B.P. and C.S.	North	68	5.281 F=1.008 df: 393, 67	59.868 t=2.021
		South	394	5.321 0.50>P>0.25	59.256 df=460 0.05>P>0.025

B.P. Basin portion C.S. Continental shelf

The western Alaska sockeye salmon south of the Islands are influenced more strongly by salinity than by water temperature. Sockeye salmon enter the Bering Sea when the density (σ_t) of the inner areas of the channels or passes between the Islands and both to the south and north side areas of the Islands becomes approximately equal. The sockeye salmon migrating northwards or eastwards move furthermore into the low salinity sea area (the low salinity water mass area extending westward and the continental slope sea area) passing through the south side of the Basin where both salinities and temperatures are comparatively high. In the continental shelf sea area dense schools of sockeye salmon were observed in the area with salinities of $32.0 \pm 0.2\%$ bordering on the coastal water near the end of the mixed water mass flowing eastwards into the inner part of Bristol Bay. Also, in the mixed water area the decrease of density (σ_t) caused by rising temperatures could help toward adjustment of osmotic function.

V-8. Change of the Gonad Weight during the Migration of the Western Alaska Sockeye Salmon from the South Side of the Aleutian Islands

Figs. V-9 and 10 show the relation between the change of the gonad weight by sex of 5₃ and 6₃ age sockeye salmon which have migrated from the south side

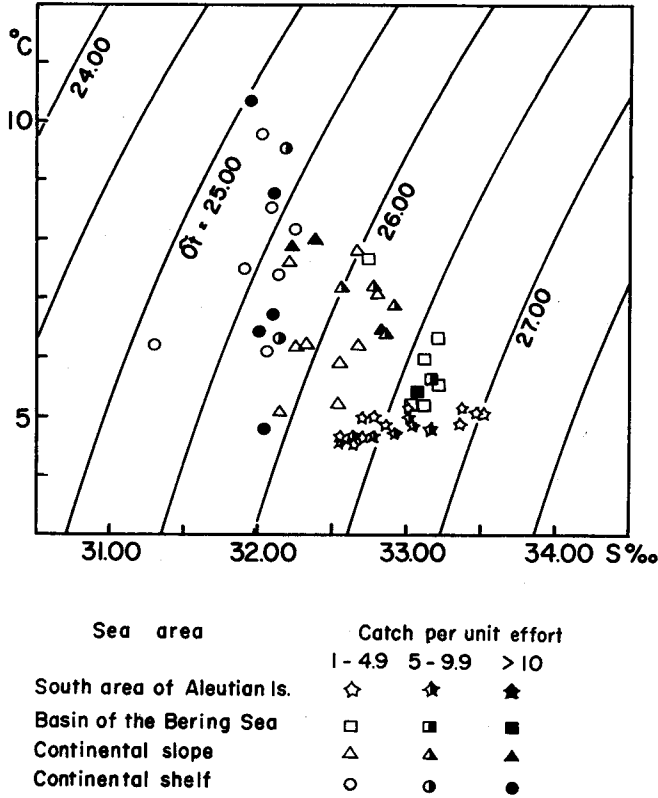

Fig. V-8. Relation between the catch of sockeye salmon and temperature-salinity (T-S diagram) at stations occupied in areas from south of the Aleutian Islands to Bristol Bay through the eastern Bering Sea.

of the Aleutian Islands to Bristol Bay and the density (σ_t), Fig. V-3 shows 5₃ age fish in 1965, and Fig. V-11 shows 6₃ age fish in 1966.

As seen in Fig. V-3, there is no change in the gonad weight of sockeye salmon (both male and female) which have remained for several days south of the Aleutian Islands. At this point, the gonad weight of females was twice of that of males, as the gonad weight of females in the North Pacific Ocean had already increased. The increase of gonad weight of males was 1.9 gr/day, and 1.5 gr/day for females in the Bering Sea. The larger increase of gonad weight of males over that of females is considered to be due to physiological differences during the migration. There was observed no difference in increase in gonad weight of sockeye salmon between fish occupying the south and north sea areas.

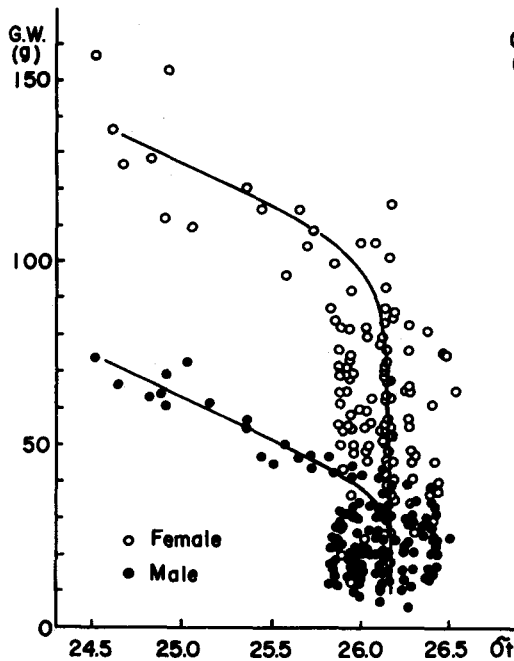

Fig. V-9. Relation between gonad weight of mature sockeye salmon in 5_s age and sigma-t in the area from south of the Aleutian Islands to Bristol Bay, through the eastern Bering Sea.

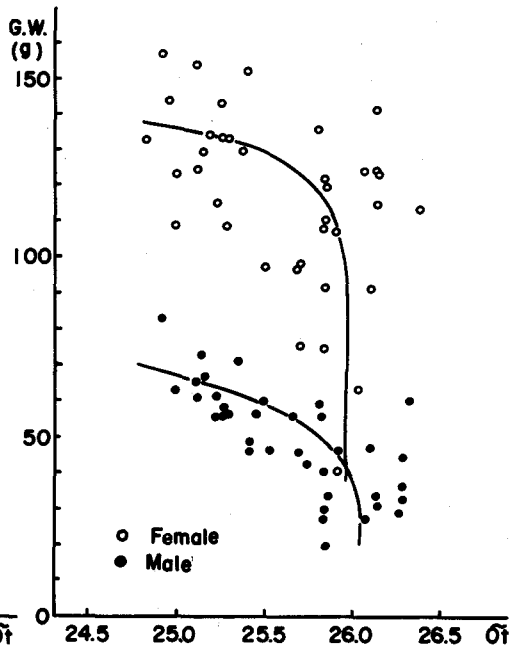

Fig. V-10. Relation between gonad weight of mature sockeye salmon of 6_s age and sigma-t in the area from south of the Aleutian Islands to Bristol Bay, through the eastern Bering Sea.

V-9. Relation between the Sockeye Salmon Offshore Fishery of Western Alaska and Oceanographic Conditions in the Aleutian Islands Area

The dense distribution of the western Alaska sockeye salmon wintering in the Gulf of Alaska and in the area south of the Alaska Peninsula is considered to have an important relation with the Alaskan Stream.

The mixed water mass flowing eastwards in Bristol Bay forms a main migration route for the western Alaska sockeye salmon. Even if the mixed water mass passing through eastern channels or passes is changed in its oceanographic properties by vertical mixing, its temperature is higher and salinity lower than the sea water entering the Bering Sea through the channels or passes between the western Aleutian Islands. This is one of the important factors in presuming that the channels through which fish schools pass are limited to the area east of the central Aleutian Islands.

As described previously, in 1957, 1961 and 1965 the western Alaska sockeye salmon moved abundantly over the tentative abstention line of 175°W into the

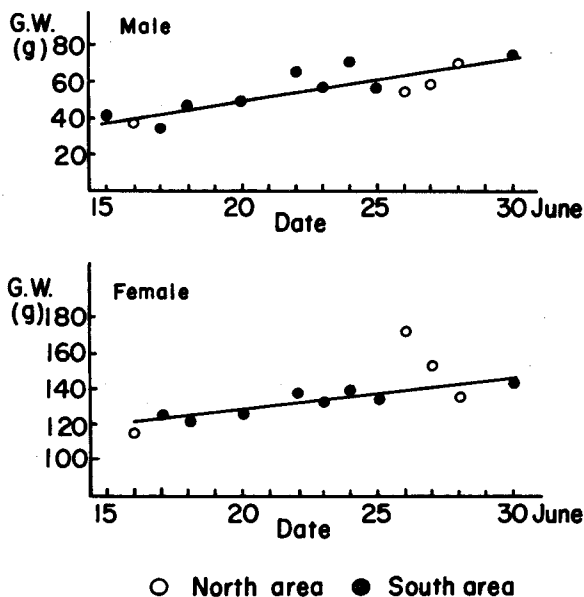

Fig. V-11. Time change of mean gonad weight of the 6₊ age group of western Alaska sockeye salmon during migration in the eastern Bering Sea, middle to late June, 1966.

western area of the North Pacific Ocean, and Japanese fishermen obtained good catch. If the entrance of the western Alaska sockeye salmon is considered normally to be limited to the eastern channels or passes, the westward movement over the limit line must be said to be abnormal. The cause and forecasting of this abnormal phenomenon are important problems to be investigated for the development and stabilization of the Japanese fishery.

VI. Conclusion

The author has discussed and clarified the relation between the homing migration of the western Alaska sockeye salmon and the oceanographic structure, from the exploratory fishing by gillnet and oceanographic observations in the eastern area of the Bering Sea aboard the *Oshoro Maru* of the Faculty of Fisheries, Hokkaido University in June and July in each year from 1962 to 1968.

A summary of the results is as follows:

1. The matured western Alaska sockeye salmon which wintered in the north-eastern area of the North Pacific Ocean approach the south side of the Aleutian Islands and move westwards along the Islands, and pass through certain channels or passes between the Islands. But in the channels or passes there is vertical mixing caused by effects of topography or of upwelling due to tidal currents, or some combination of these, and water having lower temperature and higher

salinities is formed up to the surface in the channels or passes. This water prevents the passing of the fish into the Bering Sea. This restraining effect ceases when the surface water with low temperatures and high salinities disappears owing to an abundant flow of south side water accompanied by a branch of Alaskan Stream water through the channels or passes. When the density (σ_t) of the surface layer south and north of the Islands is nearly equal, the passing of fish is possible.

2. A branch current of the Alaskan Stream entering the Bering Sea flows northwestwards along the continental slope of the eastern part of the Bering Sea, and turns westwards near $56 \sim 57^\circ\text{N}$. This current has $S \approx 33.0\%$ and is distinguishable from the normal Basin water. The north side of this lower salinity water is the north boundary of the migration of the bulk of the matured western Alaska sockeye salmon going eastwards through the lower salinity water area. Confirmation that the lower salinity water area is the north boundary of the migration route of sockeye salmon which enter the Bering Sea is provided by results obtained from tagging experiments of western Alaska sockeye salmon and from parasitological studies.

The presence of the lower salinity water is considered to be an important factor limiting migration in the deep Basin.

3. Over the continental slope a branch of the Alaskan Stream (Transverse Current) that enters the Bering Sea, flows northwestward, and the water temperature is somewhat higher than in the Basin and the continental shelf areas. This area contains mixed water area and exhibits large horizontal gradients of salinity. The mixed water is demarcated from the water of the Basin by the 33.0% isohaline.

In the continental slope area the distribution of sockeye salmon is generally denser in the southern area off the Pribilof Islands and is thin to the north. In the southern area there are observed both a halocline and a distinct thermocline at $20 \sim 50$ meters depth. The presence of water having higher temperature and lower salinities in the surface layer marks the presence of a branch of Alaskan Stream water flowing northward in the mixed water area. In the northern area there is no halocline or distinct thermocline, and the influence of the Alaskan Stream was not observed. In early summer, sockeye salmon become dense in the mixed water, into which high temperature and low salinity water has flowed, but the fish school may stay in this mixed water for a short time due to the large horizontal gradients of salinity.

4. Sockeye salmon enter into the continental shelf area when the mixed water flows into this area. In the mixed water area flowing eastwards near $56 \sim 57^\circ\text{N}$, offshore of Bristol Bay, which has comparatively high temperatures and high salinities, a dense distribution of sockeye salmon was found. Especially dense

schools were found near the boundary having $32.0 \pm 0.2\%$ of salinity.

The main contribution to this mixed water is a branch of the Alaskan Stream passing into the Bering Sea through channels or passes between the eastern Aleutian Islands. The vertically isohaline water to the south and north of the mixed water is coastal water having comparatively low temperatures and low salinities, with the salinity decreasing from offshore to the coast, and which has wintered over continental shelf. In this area sockeye salmon are thinly distributed. The mixed water in the continental shelf area is distinguished from the coastal water by the 32.0% isohaline.

The mixed water mass flowing eastwards in Bristol Bay provides a main migration route for sockeye salmon in the continental shelf area.

Sockeye salmon seem to prefer the mixed water area where the density (σ_t) decreases with rising temperature and where the salinities are greater than in the coastal water. This mixed water mass is carried into the inner part of Bristol Bay by the counterclockwise currents. Therefore the course of the eastward flow of the mixed water mass becomes the important main homing route for western Alaska sockeye salmon in the continental shelf area.

5. Comparing the 5_3 age western Alaska sockeye salmon with 6_3 age fish in 1965 and 1966, the 5_3 age fish group in the northern area were larger than that in the southern area, but the concentration of the former was less than that of the latter. As for the 6_3 age fish groups, no significant difference in the size of the body was observed between the south and north side areas.

6. Considering the important effects of water temperature and salinity on the sockeye salmon migration route from south of the Aleutian Islands to the continental slope area, the water temperature plays the predominant role among the effects, but in the route from the deep Basin to the continental shelf area, the salinity is dominant (Fig. VI-1).

7. The distribution of western Alaska sockeye salmon offshore is correlated with the Alaskan Stream. For the fish schools to enter the Bering Sea, the Alaskan Stream water must flow abundantly into the Bering Sea from south of the Aleutian Islands. The causes for the occurrence of specific fluxes of Alaskan Stream water northward may be associated with tidal currents, or more likely associated with sudden changes in weather (e.g. approaching or passing of a depression). In the migration period, depressions pass frequently through there areas. The water mass which passes through the eastern channels or passes is of higher temperature and lower salinity than that passing through the western channels or passes, and consequently the passing of the fish schools is thought to be limited to the eastern channels or passes between the Islands.

8. The habits of the western Alaska sockeye salmon observed during their homing migration have a remarkable relation to the environmental conditions, and

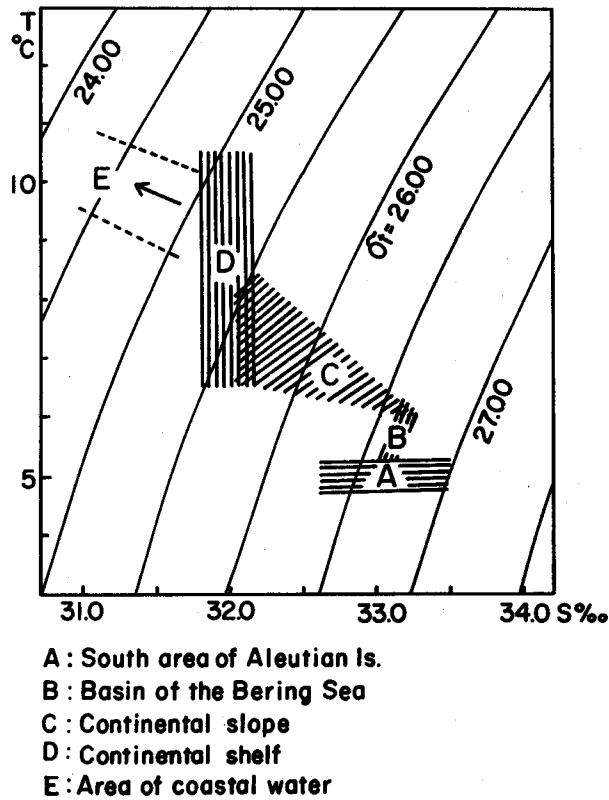

Fig. VI-1. Schematic diagram of the migration route of sockeye salmon from the area south of the Aleutian Islands to the Bristol Bay.

it is considered that the formation of each race of sockeye salmon is the result of adaptation to the environmental conditions, like many other kinds of living creatures. Therefore, the study of the living environments of the genus *Oncorhynchus* in the marine period in their life history is important not only from a biological point of view, but also from the viewpoint of proper resource control of the commercially valuable sockeye salmon.

VII. Acknowledgements

The data referred to by the author were obtained from the records of Japanese scientific investigations under the Japanese-American-Canadian Fishery Treaty and Japanese-Russo Fishery Treaty. Some of the data were also obtained from K.K. Kyokuyo and Nichiro Fishery K.K. The investigations have been carried out under financial support from the Fisheries Agency of the Japanese Government.

The author appreciates the cooperation of scientific investigators, students and crew members of the *Oshoro Maru* who endeavored to collect and estimate the samples on board, frequently under adverse weather conditions.

The author also thanks Dr. T. Nishiyama, Faculty of Fisheries, for preparing the biological samples, Professor K. Kyushin for certain calculations and Assist. Prof. Y. Akiba, Dr. K. Ohtani and Assist. Prof. T. Suzuki for their useful advice.

The author is also indebted to Professors M. Konda, Y. Takenouchi and Professor T. Tujita for their kind guidance and advice, and the ex-Dean Dr. E. Tanikawa of the Faculty of Fisheries, Hokkaido University, for his encouragement during the work.

VIII. Summary

1. Investigation of the distribution of the genus *Oncorhynchus* by gillnets and concurrent oceanographic surveys during June and July each year from 1962 to 1968 in the eastern area in the Bering Sea have been undertaken from the *Oshoro Maru*, a training ship of Faculty of Fisheries, Hokkaido University. Using the results, the author has studied the relations between the homing migration of the western Alaska sockeye salmon and the oceanographic structure.

2. The genus *Oncorhynchus* distribution in the sea area lying north of the polar front of the northern North Pacific Ocean is an important fishing resource for U.S.A., U.S.S.R., Canada and Japan, adjacent to the sea. In the order of catch, pink salmon (*Oncorhynchus gorbuscha*), chum salmon (*O. keta*), sockeye salmon (*O. nerka*), silver salmon (*O. kisutch*) and king salmon (*O. tshawytscha*) are mentioned, of which the annual average catch is about 400 thousand tons. Among them, the catch of sockeye salmon is about 73 thousand tons, and has the highest economic value.

3. Sockeye salmon, which is the fishing objective for the Japanese fishery, are divided into three local groups, Kamchatka-west-coast group, Kamchatka-east-coast group and western Alaska group. The stock level of the western Alaska group is higher than that of the Asian groups.

4. The western Alaska sockeye salmon gather south of the Aleutian Islands from May to June. These salmon do not enter immediately into the Bering Sea, but remain south for a while before entering the Bering Sea through particular channels or passes. In the channels or passes there is normally upwelling due to the influence of the shape of the sea bottom interacting with the tidal currents, and the surface layer water having lower temperature and higher salinity becomes a factor preventing the passing of sockeye salmon into the Bering Sea. Consequently, for passage a water mass with lower temperatures and higher salinities formed in the surface layer in the channels or passes must disappear. The water mass disappears when there occurs rapid and abundant flow into the Bering Sea,

between May to June. Under these oceanographical conditions the sockeye salmon easily enter the Bering Sea. The disappearance of the water mass occurs when on spring tides the water south of the Islands is accelerated northwards through the channels, or when there occurs strong south winds caused by an approaching depression.

5. Water in the upper layer of the deep Basin area has lower temperature and higher salinities than that in the area south of the Aleutian Islands. After entering the Bering Sea the western Alaska sockeye salmon increase their speed and move northwards or eastwards in the Basin. But when the fish reach the water mass extending westwards near 57°N over the eastern continental slope area with lower salinity, the fish do not pass northwards through this lower salinity area. The homing migration route of the main school of the western Alaska sockeye salmon is formed in the lower salinity sea area and to the south.

6. The continental slope area has a current composed in part of the Alaskan Stream water (Transverse Current) flowing northwestward, where the water temperature is higher than in the deep Basin and the continental shelf area. This continental slope area is a mixed water area with large horizontal gradients and is distinguished from the deep Basin area by the 33.0‰ isohaline. Sockeye salmon stay in this mixed water area. The concentration of sockeye salmon is dense in the south part of this mixed water area and thinner in the north part.

7. The entrance of sockeye salmon from the continental slope area into the continental shelf area coincides with the movement of the mixed water mass.

The main migration route is eastward from between Unimak and Pribilof Islands like a wedge into the inner part of Bristol Bay on the continental shelf. Especially dense concentrations are observed at the boundaries of this mixed water mass. The approach of this dense population of sockeye salmon to the coast of Alaska proper forms the object of the highest fishing intensity in Bristol Bay during early and middle July. The mixed water area is distinguished from the continental shelf coastal water by the 32.0‰ isohaline.

8. In the lower salinity area which extends westwards in the deep Basin area in the eastern part of the Bering Sea, and along its southern side, and the mixed water area which moves eastwards in Bristol Bay in the continental shelf sea area and its southern side, sockeye salmon of 5_3 and 4_2 ages, which have wintered for shorter periods in the ocean, are observed to be more densely distributed than in the north of these areas. The western Alaska sockeye salmon of predominantly 6_3 and 5_2 age fish which have wintered for longer periods in the ocean also avoid the northern areas.

9. As to the route of homing migration of the western Alaska sockeye salmon from south of the Aleutian Islands to Bristol Bay, the migration is strongly influenced by the water temperature to the south of the Aleutian Islands, and also

by salinity (and hence density (σ_t)) in the eastern Bering Sea.

10. The offshore distribution of the western Alaska sockeye salmon is related to the Alaskan Stream. Especially for the entrance of sockeye salmon schools into the Bering Sea requires an abundant flow of water from the south side of the Aleutian Islands into the Bering Sea. The periods of this flow are considered to be spring-tides, or sudden changes of weather (e.g. approach or passing of a depression). But the spring-tide is a regular phenomenon, while the migrating period appears to agree rather with the season in which depressions frequently approach or pass. The water flowing through the channels or passes between eastern Aleutian Islands into the Bering Sea has higher temperatures and lower salinities than that from the western Aleutian Islands. From these facts, the passing route of the sockeye salmon is considered to be limited to the eastern channels or passes.

11. It is pointed out that the habits of the western Alaska sockeye salmon observed during their homing migration have a remarkable relation to the environmental conditions, and it is considered that the formation of each race of sockeye salmon is the result of adaptation to the environmental conditions, like many other kinds of living creatures. Therefore the study of the living environments of the genus *Oncorhynchus* in the marine period in their life history is important not only from a biological point of view, but also from the viewpoint of proper resource control of the commercially valuable sockeye salmon.

References

- Barnes, C.A. and Thompson T.G. (1933): Physical and chemical investigation in Bering Sea and portions of the north Pacific Ocean. *Univ. Wash. Publ. in Oceanography* 3, 35-79.
- Birman, I.B. (1967a): Relation of Pacific salmon races in marine time. (in Japanese) *Collection of Literatures of Soviet North Pacific Fishery* 81, 38 pp.
- Birman, I.B. (1967b): Salmonidae in the marine life. (in Japanese) *Collection of Literatures of Soviet Northern Pacific Fishery* 83, 5-37.
- Callaway, R.T. (1963): Ocean conditions in the vicinity of the Aleutian Islands, Summer 1957. *INPFC Bull.* 11, 27 pp.
- Cobb, J.N. (1930): Fishing grounds and history of the fisheries. *Pacific salmon Fisheries, U.S. Dept. of Comm.*, 422-476.
- Dobrovolskii, A.D. and Arsenev, V.S. (1959): On the problems in the Streams in the Bering Sea. (in Japanese) *Collection of Literatures of Soviet Northern Pacific Fishery*, 37, 7-16.
- Dodimead, A.J. (1958): Oceanographic observation in the neighbourhood of the Aleutian Islands. (in Japanese) *Collection of Literatures in the northern Pacific Fishery, American-Canadian* 11, 57-69.
- Dodimead, A.J., Favorite, F. and Hirano, T. (1963): Salmon of the north Pacific Ocean Part. II. Review of Oceanography of the Subarctic Pacific Region. *INPFC Bull.* 13, 176 pp.
- Dominead, A.J., Favorite, F. and Hirano, T. (1963): Oceanography of Bristol Bay *INPFC Bull.* 13, 177-189.
- Dryagin, P.A. (1953): The age composition of fish population. (in Japanese) *Collection of*

1975] FUJII: Homing migration of western Alaska sockeye and oceanic conditions

Literatures of Soviet North Pacific Fishery, 41, 10 pp.

- Dunn, J.R. (1969): Direction of movement of salmon in the North Pacific Ocean, Bering Sea and Gull of Alaska as indicated by surface gillnet catches 1962-1965. *INPFC Bull.* 26, 13-26.
- Favorite, F. and Hanavan M.G. (1963): Oceanographic condition and salmon distribution south of the Alaska Peninsula and Aleutian Islands 1956. *INPFC Bull.* 11, 57-72.
- Favorite, F. (1967): Alaskan Stream. *INPFC Bull.* 21, 18 pp.
- Fisheries Agency of Japan (1969): The data on the state of resources in Bristol sockeye salmon. *The data on the state of resources in Pacific salmon* 10, 16-24.
- French, R. and Mason, J.E. (1964): Salmon distribution and abundance on the high-sea winter season 1962 and 1963. *INPFC Ann. Rept.* 1963, 131-141.
- French, R. (1965): Studies on the salmon distribution and abundance. *INPFC Ann. Rept.* 1964, 84-93.
- Fujii, T., Abe, S., Saito, S., Masuda, K. and Nakane, S. (1961): Exploratory fishing of salmon with gillnets of various mesh sizes and with a trammel net in Aleutian water 1957. (in Japanese) *Bull. Fac. Fish. Hokkaido Univ.* 12, 129-137.
- Fujii, T., Yamamoto, S., Masuda, K., Kobayashi, G. and Nishiyama, T. (1968): Inference on direction of movement of Pacific salmon in the Bering Sea from the relationship between the direction of gillnet set and the amount of the catch. (in Japanese) *Bull. Fac. Fish. Hokkaido Univ.* 18, 306-316.
- Fujii, T. (1968): Water mass and distribution of red salmon in the Bering Sea (Alaska continental shelf and Bristol Bay). (in Japanese) *Bull. Japan. Society Fish. Ocean.* 13, 38-45.
- Fujii, T. (1969): Environment of fishing ground of red salmon in the Bering Sea. (in Japanese) *Bull. Japan. Society Fish. Ocean.* 15, 96-102.
- Fujii, T. (1970): A factor on the migration of the red salmon of Bristol origin from the sea areas of the south of Aleutian Islands to the Bering Sea. (in Japanese) *Bull. Japan. Society Fish. Ocean.* 17, 179-184.
- Fukuhara, F.M., Murai, S., LaLanne, J.J. and Sribhibhadh, A. (1962): Continental origin of red salmon as determined from morphological characters. *INPFC Bull.* 8, 15-109.
- Gall, V.J.L. (1937): Die treibnetz-fischerei auf makrelen. *Die Franzoesische Seefischerei, Handbuch der Seefischerei Nordeuropas.* VII, 55-63.
- Gershanovich, D.E. (1962): Andulation of the bottom on the continental shelf and bottom materials in the Bering Sea (in Japanese) *Collection of Literatures of Soviet northern Pacific Fishery* 54, 31-60.
- Hanamura, N. (1966): Some problems in the stock study on red salmon. (in Japanese) *Bull. Japan. Society Fish. Ocean.* 9, 42-46.
- Hanamura N. (1967): The fishing condition of red salmon in the North Pacific in 1966 (in Japanese) *Bull. Japan. Society Fish. Ocean.* 11, 41-50.
- Hanavan, M.G. and Tanonaka, G.K. (1959): Experimental fishing to determine distribution of salmon in the North Pacific Ocean and Bering Sea, 1956. *U.S. Fish and Wildlife Ser. Sp. Scie. Rept. Fish.* 302, 22 pp.
- Hartt, A.C. (1962): Movement of salmon in the North Pacific Ocean and Bering Sea as determined by Tagging 1956-1958. *INPFC Bull.* 16, 157 pp.
- Hartt, A.C. (1966): Migration of salmon in the North Pacific Ocean and Bering Sea as determined by Seining and Tagging, 1959-1960. *INPFC Bull.* 19, 141 pp.
- Hebard, J.F. (1959): Currents in southeastern Bering Sea and possible effects upon king crab larvae. *U.S. Fish and Wildlife Ser. Sp. Scie. Rept. Fish.* 293, 11 pp.
- INPFC (International North Pacific Fisheries Commission) (1962, 1963, 1964, 1965, 1966, 1967): Salmon catch in the Alaska by week in number of fish. *Statistical Yearbook* 1962, 20 pp., 1963, 30 pp., 1964, 33 pp., 1965, 32 pp., 1966, 31 pp., 1967, 31 pp.

- Ishida, T. (1966): The theory and the practical of mesh size selection used by gillnet. (in Japanese) *Fishery Sci.*, **11**, 6 pp.
- Johnsen, R.C. (1964): Direction of movement of salmon in the North Pacific Ocean and Bering Sea as indicated by surface gillnet catches, 1959-1960. *INPFC Bull.* **14**, 29-42.
- Kasahara, H. (1963): Catch statistics for North Pacific Salmon. *INPFC Bull.* **12**, 7-82.
- Konda, M. (1959): Study on the Pacific salmon distribution sphere in the high sea. (in Japanese) *Japan. Dept. Fish. Agen. Japan-Soviet fish. data.* 33 pp.
- Konda, M. (1963) The distribution of Pacific salmon. Salmon mother ship fishing, (in Japanese) *Pelagic Fishing text*, **19** pp.
- Kondo, H., Hirano, Y., Nakayama, N. and Miyake, M. (1965): Offshore distribution and migration of Pacific salmon (genus *Oncorhynchus*) based on tagging studies (1958-1961). *INPFC Bull.* **17**, 213 pp.
- Kubo, I. and Yoshihara, T. (1957): Fisheries Resources. 345 pp. (in Japanese) Kyoritus Shuppan, Tokyo.
- Landrum, B.J. and Dark, T.A. (1968): The distribution of mature Western Alaska and Kamchatkan sockeye salmon (*O. nerka*) in the North Pacific Ocean and Bering Sea. *INPFC Bull.* **24**, 110 pp.
- Larkins, H.A. and French, R.R. (1964): Effect of direction of set and distance between nets on the salmon catch of two gill nets. *INPFC Bull.* **14**, 59-65.
- Machidori, S. (1966): Vertical distribution of Pacific salmon in the Northwestern Pacific Ocean -I (in Japanese) *Bull. Hokkaido Reg. Fish. Res. Lab.* **31**, 11-17.
- Machidori, S. (1967): Ditto -II, (in Japanese) *Bull. Hokkaido Reg. Fish. Res. Lab.* **33**, 13-20.
- Machidori, S. (1968): Ditto-III, (in Japanese) *Bull. Hokkaido Reg. Fish. Res. Lab.* **34**, 11 pp.
- Maeda, T. (1959): Study on the Salmon Fishing Grounds in the North Pacific Ocean. (in Japanese) *Bull. Fac. Fish. Hokkaido Univ.* **9**, 268-282.
- Manzer, J.I., Ishida, T., Peterson, A.E. and Hanavan, M.G. (1965): Salmon of the North Pacific Ocean-Part V, Offshore distribution of salmon. *INPFC Bull.* **15**, 53 pp.
- Margolis, L., Cleaver, F.C., Fukuda, Y. and Godfrey H. (1966): Salmon of the North Pacific Ocean-Part VI, Sockeye Salmon in offshore waters. *INPFC Bull.* **20**, 70 pp.
- Mishima, S. and Nishizawa S. (1955): Report on hydrographic investigations in Aleutian waters and the Southern Bering Sea in the Early Summers of 1953 and 1954. (in Japanese) *Bull. Fac. Fish. Hokkaido Univ.* **6**, 85-124.
- Miyake, M. (1965): Offshore distribution and migration of Pacific salmon (genus *Oncorhynchus*) based on tagging studies (1958-1961). *INPFC Bull.* **17**, 213 pp.
- Neave, F. (1960): Observations of the vertical distribution of salmon in the Northeast Pacific 1960. *INPFC Doc.* **408**.
- Oceanographical Society of Japan (1955): The Guide Book of Oceanographic Survey. p. 14-181. *Chemical analysis of marine water.* (in Japanese).
- Ohtani, K. (1969): On the Oceanographic Structure and the Ice Formation on the Continental Shelf in the Eastern Bering Sea. (in Japanese) *Bull. Fish. Hokkaido Univ.* **20**, 94-117.
- Ratmanoff, G.E. (1937): Exploration of the seas of Russia. *Publ. Hydrological Inst.* **25**, 175 pp.
- Rich, W.H. and Ball, E.M. (1928): Statistical review of the Alaska salmon fisheries. Part 1. Bristol Bay and Alaska Peninsula. *Bull. U.S. Bureau of Fish.* **44** (Doc. 1014).
- Saur, J.F.T., Lesser, R.M., Carsola, A.J. and Cameron, W.M. (1952): Oceanographic cruise to the Bering and Chukchi Seas, summer 1949. *U.S. Navy Elect. Lab.*, 38 pp.
- Taguchi, K. (1957 a): The Seasonal Variation of the Good Fishing Area of Salmon and the Movement of Water Masses in the Waters of Western North Pacific-I. Distribution and Movement of water Masses. (in Japanese) *Bull. Japan. Soc. Sci. Fish.* **22**, 511-514.

1975] FUJII: Homing migration of western Alaska sockeye and oceanic conditions

- Taguchi, K. (1957 b): Ditto-II. The distribution and migration of salmon population in offshore waters. (in Japanese) *Bull. Japan. Soc. Sci. Fish.* **22**, 515-521.
- Taguchi, K. (1957 c): Ditto-III. Relation between the distribution of salmon population and oceanographical condition mainly in the southern waters of 48°N. Lat. (in Japanese) *Bull. Japan. Soc. Sci. Fish.* **22**, 609-617.
- Taguchi, K. (1966): The Salmon Resources and Salmon Fisheries Around the Pacific Ocean. 386 pp. (in Japanese) *Koseisha Koseikaku*, Tokyo.
- U.S. Coast and Geodetic Survey (1955): Alaska, Cape Spencer to Arctic Ocean. *U.S. Coast Pilot* **9**, 673 pp.
- U.S. Navy Hydrographic Office (1958): Oceanographic survey results, Bering Sea winter and spring 1955. *U.S. Navy Hy. Off. Tec. Rept.* **46**, 95 pp.
- Watanabe, N. (1954): Oceanographic survey report in the salmon fishing ground in the North Pacific Ocean, 1952 and 1953. (in Japanese) *Tokai Reg. Fish. Res. Lab. Sp. Rept.* **3**, 5 pp.

Appendix table 1. Number of salmon catch per ton on the middle Aleutian waters and the Bering Sea from late May to late June, 1965.

Date	KI. Fleet					Oshoro Maru					K. Research Vesel					S. Fleet								
	Position		Species			Position		Species			Position		Species			Position		Species						
	Lat. N.	Long. W.	S.	C.	P. To'l	Lat. N.	Long. W.	S.	C.	P. To'l	Lat. N.	Long. W.	S.	C.	P. To'l	Lat. N.	Long. W.	S.	C.	P. To'l				
May 30	50.5,	177.7																						
31	50.6,	177.8	6.0	0.3	0.1	6.4																		
June 1	50.6,	177.7	7.2	0.3	0.1	7.6					52.4,	176.7	0.1	0	0	0.1								
2	50.6,	177.8	4.7	0.3	0.2	5.2					53.5,	177.6	2.9	0.3	0	3.2								
3	50.9,	177.8	2.9	0.2	0.2	3.2					53.6,	178.3	2.3	0.2	0	2.5								
4	50.8,	177.7	1.8	0.2	0.2	2.2	56.9,	174.1E	0.3	0.2	0	0.5	53.6,	179.0	3.6	0.9	0	4.5						
5	50.6,	177.6	1.6	0.1	0.3	2.0					53.5,	177.7	2.5	0.1	0	2.6								
6	50.5,	177.3	1.8	0.1	0.3	2.2																		
7	50.6,	177.4	1.1	0.1	0.2	1.4	59.4,	179.6	0.7	0	0	0.7	54.6,	177.8	6.2	0.3	0	6.5						
8	50.7,	177.2	1.6	0.1	0.1	1.8					54.3,	178.5	3.5	0.3	0	3.8								
9							58.5,	175.0	0.3	0.4	0	0.7	53.7,	179.3E	1.3	0.1	0	1.4						
10							57.1,	178.2	0.7	0.6	0	1.3	53.0,	178.6E	6.5	0	0	6.5						
11							55.0,	179.1	0.9	0.8	1.1	2.8	53.5,	178.5E	10.4	0	0	10.4						
12							53.2,	178.1	11.4	0.2	0	11.6	52.6,	179.0E	6.7	0	0	6.7						
13							53.5,	177.2	1.5			1.6	52.7,	179.8E	7.5	0	0	7.5						
14													52.9,	179.3	4.4	0	0	4.4						
15													54.1,	178.3	16.0	0	0	16.0						
16													54.8,	177.5	11.7	0	0	11.7						
17																								
18							53.5,	172.0	1.9	0	0	1.9	56.4,	175.9	26.0	0	0	26.0						
19							54.8,	174.1	10.4	0	0	10.4												
20							55.5,	172.6	8.8	0.4	0	9.2												
21																								
22																	57.0,	179.0	0.6	1.1	0.5	2.2		
23							58.5,	165.0	0.1	2.7	0.1	2.9					57.7,	177.2	2.9	0.8	0.2	3.9		
24							57.0,	165.0	1.8	1.3	0.1	3.2	58.0,	179.9	0.5	1.5	1.5	*3.5	58.7,	176.5	0.6	1.1	0.5	2.2
25							55.5,	165.0	0.9	0.2	0	1.1	59.2,	179.1	0.6	0.8	0.8	2.2	58.6,	176.2	1.9	2.2	0.5	*4.7
26							56.3,	165.0	55.7	0.4	0	56.1	59.6,	176.0	0.2	0.8	1.0	2.0	58.7,	176.2	0.9	2.4	0.7	*4.8

Species; S.....Sockeye C.....Chum P.....Pink To'l....Total *....included Chinook

Appendix table 2. Comparison between temperature, salinity and catch of salmon at the same position (54.9°N, 169.4°W) with the lapse of the day on the continental slope of the southeastern Bering Sea, late June, 1964.

Date (St.)	Depth (m)	Temp. (°C)	Salinity (‰)	No. of gillnets	Catch of fish			
					Species	No. of fish	Catch/tan	%
June, 21 (F-9)	0	7.1	32.81	119	Sockeye	575	4.83	77.1
	10	7.01	32.81		Chum	154	1.29	20.6
	20	5.40	32.92					
	30	4.34	32.97		Pink	12	0.10	1.6
	50	4.02	33.04					
	75	4.08	33.12		Chinook	5	0.03	0.7
	100	3.95	33.21					
	150	3.77	33.37					
	200	3.93	33.51		Σ	746	6.25	100
300	3.89	33.69						
June, 22 (F-10)				116	Sockeye	908	7.83	70.6
					Chum	366	3.16	28.5
					Pink	7	0.06	0.5
					Chinook	5	0.04	0.4
					Σ	1286	11.09	100.0
June, 23 (F-11)	0	7.2	32.79	116	Sockeye	991	8.54	80.7
	10	7.14	32.77		Chum	224	1.93	18.3
	20	7.04	32.97					
	30	5.17	32.97		Pink	9	0.08	0.7
	50	4.46	32.99					
	75	4.01	33.12		Chinook	4	0.02	0.3
	100	3.73	33.21					
	150	3.82	33.37					
	200	3.81	33.53		Σ	1228	10.57	100.0
300	3.91	33.75						
June, 28 (F-13)	0	6.9	32.76	113	Sockeye	57	0.50	83.8
	10	6.62	32.77		Chum	10	0.09	14.7
	20	6.58	32.76					
	30	5.64	32.81		Pink	1	0.01	1.5
	50	3.78	32.92					
	75	3.37	32.99		Chinook	0	—	—
	100	3.07	33.01					
	150	3.16	33.21					
	200	3.83	33.39		Σ	68	0.06	100.0
300	4.03	33.64						

Appendix table 3. *Data on salmon gillnets operation of the Bertha Ann in winter 1963. (French et al., 1964)*

No. of fishing station	Date	Position		No. of used gill nets (shackles)	Species		
		Lat.(N)	Long.		Sockeye	Chum	Pink
1	Jan. 28	52°40'	179°21'W	30	23	0	0
2	" 29	53°27'	179°53' E	30	34	0	0
3	" 30	54°34'	179°55' E	22	6	0	0
4	Feb. 1	55°30'	179°58' E	32	36	0	0
5	" 2	56°32'	179°43' E	30	15	0	0
Total Catch per shackle				144	114 0.79	0 0	0 0
6	Feb. 4	56°25'	175°28' E	32	78	0	0
7	" 5	57°28'	175°00' E	32	38	0	0
8	" 6	55°29'	174°50' E	32	37	0	0
9	" 7	54°26'	174°57' E	32	17	2	0
Total Catch per shackle				128	170 1.33	2 0.02	0 0

Appendix table 4. *Age composition of sockeye salmon caught by the Bertha Ann in winter 1963. (French et al., 1964)*

No. of fishing station	1 winter-at-sea				2 winter-at-sea					3 winter-at-sea					4 winter-at-sea		no data age	Total
	3 ₂	4 ₂	5 ₂	no revise	3 ₁	4 ₂	5 ₂	6 ₂	no revise	4 ₁	5 ₂	6 ₂	7 ₂	no revise	6 ₂	no revise		
1		1	1	1		2	7	1			1	5	2			1	22	
2	1	2	1			4	10	1	2	1	2	7	1		2		34	
3		1				1					2	2					6	
4						2	4	1	2		9	14	2	2			36	
5						1	1				2	7	1			3	15	
Total %	1	4	2	1		10	22	3	4	1	16	35	5	3	2	4	113	
															1.8	3.5	100	
6		1				1	7	1		1	28	30	4	4		1	78	
7							2				9	18	4	3	2		38	
8							3	1			17	10	2	2			37	
9	2	3					1				7	3	1			2	17	
Total %	2	4				1	13	2		1	61	61	11	9	2	3	170	
															1.2	1.8	100	

Appendix table 5. Comparison of catch of salmon at different area as north and south area in Basin portion of the Bering Sea, 1966 and 1967.

	Date	Position		Area	Sea temp. (°C)	Amount of gill nets	Sockeye	Chum	Pink
		Lat.(N)	Long.						
1966									
F 1	June 13	53°30'	177°00' E	●	4.9	115	14	12	67
F 2	14	55°30'	177°00' E	●	4.4	115	68	42	80
F 3	15	57°30'	170°00' E	○	4.2	115	37	33	19
F 4	17	58°18'	176°05' W	○	4.8	115	8	25	6
F 5	18	56°03'	176°01' W	●	5.5	115	36	11	9
1967									
F 1	12	53°53'	178°00' W	●	5.7	118	119	11	4
F 2	15	58°00'	178°23' W	○	5.9	123	55	11	15

○.....North area ●.....South area