



HOKKAIDO UNIVERSITY

Title	A NOVEL APPROACH FOR THE IDENTIFICATION OF LIPID MOLECULAR SPECIES : Application of High Performance Liquid Chromatography on Fish Muscle Lecithin Molecular Species Analysis
Author(s)	Takahashi, Koretarō
Citation	MEMOIRS OF THE FACULTY OF FISHERIES HOKKAIDO UNIVERSITY, 32(2), 245-330
Issue Date	1985-12
Doc URL	https://hdl.handle.net/2115/21879
Type	departmental bulletin paper
File Information	32(2)_P245-330.pdf



A NOVEL APPROACH FOR THE IDENTIFICATION OF LIPID MOLECULAR SPECIES

Application of High Performance Liquid Chromatography on Fish Muscle Lecithin Molecular Species Analysis

By

Koretarō TAKAHASHI

*Laboratory of Food Chemistry I, Faculty of Fisheries,
Hokkaido University, 3-1-1 Minato-cho, Hakodate*

Acknowledgments

The author is deeply indebted to Prof. Kōichi Zama under whose supervision this investigation was conducted. His ideas and advices throughout the study were invaluable.

The useful suggestions of Prof. Tōru Takagi in preparation of this manuscript are greatly appreciated.

Associate Prof. Mutsuo Hatano Kindly accepted the reviewer.

Sincere gratitude to Associate Prof. Kōzō Takama for guiding and for drawing the authors attention to this problem.

This work would not have been possible without the help of Mr. Tsugihiko Hirano.

The author was favored to have the assistance of Mr. Hideaki Ebina.

Mr. Makoto Egi did the computer programming.

Thanks are due to Dr. Masahiko Kunimoto and to Mr. Seiichi Ando for the encouragement.

Contents

	Page
Acknowledgments	245
Nomenclature and Abbreviations	246
General Introduction	246
CHAPTER I. Identification of Lecithin Molecular Species on Reversed-Phase High Performance Liquid Chromatography: A New Concept that Helps the Molecular Species Determination	248
Section 1. Experimental	249
Section 2. Results	250
Section 3. Discussion	262
CHAPTER II. A Novel Approach for the Identification of Triglyceride Molecular Species on Reversed-Phase High Performance Liquid Chromatography	264
Section 1. Experimental	265
Section 2. Results	266
Section 3. Discussion	268
CHAPTER III. Lecithin Molecular Species Identification Program for the Personal Computer	274
Section 1. Lecithin Molecular Species Identification Program Version I.	274

Section 2. Lecithin Molecular Species Identification Program Version II.	275
CHAPTER IV. Molecular Species of Fish Muscle Lecithin	280
Section 1. Experimental	280
Section 2. Characteristics of Muscle Lecithin of Fish	280
Section 3. Characterization of Each Fish by Principal Component Analysis	288
Section 4. Changes in Fish Muscle Lecithin of Chum Salmon during Migration ..	308
CHAPTER V. General Summary and Conclusions	322
References	327

Nomenclature and Abbreviations

22 : 6	represents a fatty acid with a chain length of 22 carbon atoms with six double bonds
GLC	Gas liquid chromatography
HPLC	High performance liquid chromatography
TLC	Thin layer chromatography
PL	Phospholipid
PC	Lecithin, Phosphatidylcholine
PS	Phosphatidylserine
PE	Phosphatidylethanolamine
NP	Non phospholipid
DG	Diglyceride
ST	Sterol
FFA	Free fatty acid
TG	Triglyceride
MS	Molecular species
RRT	Relative retention time
CN	Total acyl carbon number
DB	Number of total double bonds
PN	Partition number
ECN	Equivalent carbon number
EC	Effective carbon number
Acyl	Acyl group
E	Glycerol residue
$a \in A$	a belongs to A
μ	Chemical potential
DM	Dark muscle
WM	White muscle
PCA	Principal component analysis
ACC.%	Accumulative value of the contribution.

General Introduction

Analytical techniques or instruments have been developed for fatty acid analysis. Resultingly, much knowledge has been achieved on the study of fatty acid analysis.

In contrast to this, the study of molecular species, namely, the study of the intact or unmodified lipid is still away behind of development. This might be due to the limited and time consuming conventional techniques represented by silver nitrate impregnated thin layer chromatography (Ag^+ -TLC) followed by gas liquid chromatographic analysis (GLC) (such examples are too numerous to mention).

Generally speaking, Ag⁺-TLC can separate only up to heptaene. And GLC can analyze quantitatively only up to 700~800 molecular weight. If the sample contains highly unsaturated fatty acids such as 20:4, 20:5 or 22:6, the degree of unsaturation will drastically increase and exceeds the analytical limit of the Ag⁺-TLC.

Fats and oils from marine sources are rich in highly unsaturated fatty acids. Accordingly, it is almost impossible to analyze the molecular species from these sources by the conventional method¹⁾.

High performance liquid chromatograph has become the most expected instrument in separating the nonvolatile or high molecular weight compound. Since there are significant amount of triglycerides in marine lipid that exceed the molecular weight of 800 which is the limit of GLC, the utilization of high performance liquid chromatography (HPLC) is expected to separate the molecular species of lipids from these sources. The reversed-phase type HPLC²⁻⁴⁾ is becoming the main analytical type in separating the most analogous compounds⁵⁾. The earlier workers in this field tried to characterize the chromatographic rules such as partition number (PN)^{6,7)} or effective carbon number (EC)⁸⁾ which are defined as $PN = CN - 2 \times DB$ and $EC = CN - DB$, respectively, in the elution of triglyceride or lecithin molecular species. CN is the total acyl carbon number and DB is the total double bonds in the molecule. This empirical equations were useful in predicting the approximate retention value (in practical cases, retention time or retention volume) though these equations lacked the theoretical background. In the same year, Plattner *et al.*^{9,10)} has proposed equivalent carbon number (ECN) which is the same concept with PN. And recently, in accordance with the improvement of separation on HPLC, theoretical carbon number (TCN) has been proposed by Perkins *et al.*¹¹⁾ In 1982, the generalized form of ECN (or PN) and EC has been presented by Compton *et al.*¹²⁾ that can be written as $I_u = I_s - C \cdot D_b$, where I_s is the carbon number of the standard alkane, D_b is the total double bonds in the molecule and I_u is the index observed for unsaturated triglyceride and phospholipid molecular species by the coefficient of C.

In this study, the formulae that control the sequence of elution of lipid molecular species on reversed-phase HPLC are proposed. The theoretical aspect of the presented formulae has been discussed in relation to ECN (or PN). And it is demonstrated that the formulae proposed in this study might be invariant rules.

Lecithin (phosphatidylcholine) were analyzed by HPLC from various sources including those from fish muscle. Though there are some reports concerning the phospholipid molecular species analysis done by HPLC from land sources¹³⁻²⁰⁾, the study done by the author might be the only example that have worked on the phospholipid molecular species analysis on HPLC from fish lipid except the conventional way of analysis based on the probability simulation done by Oshima *et al.*²¹⁻²⁵⁾

In chapter I, it is demonstrated that the modification of lecithin into diglyceride acetate via diglyceride is necessary for the reversed-phase type HPLC analysis in order to have a sufficient separation between the critical pairs that have the same ECN, PN or EC. And a new matrix model is proposed instead of the ECN, PN or EC concept.

In chapter II, the proposed matrix model that exhibits the chromatographic

rules of diacyl type molecular species is developed into the rules for triacyl type molecular species such as triglycerides. And the physicochemical background, as well as the theoretical relationship between the ECN (or PN) and the new matrix model, is demonstrated.

In chapter III, the lipid molecular species identification software is designated for the personal computer. The accumulated data were fully utilized for the actual identification since the equation that regulates the sequence of molecular species inevitably contains errors due to the deviation of relative retention time (RRT) on HPLC.

In chapter IV, characteristics of several kinds of fish including cartilaginous fish, as well as fresh water fish, are discussed from the view point of muscle lecithin.

In the final chapter, summary and conclusion of this work is described with a few supplemental discussion.

CHAPTER I
Identification of Lecithin Molecular Species on
Reversed-Phase High Performance Liquid
Chromatography
A New Concept that Helps the Molecular
Species Determination

A satisfactory separation of lecithin molecular species from natural sources including those from marine sources was made by modifying the lecithin into diglyceride acetate for HPLC analysis.

In this chapter, the necessity of modification of lecithin into diglyceride acetate through the hydrolysis by phospholipase C and the subsequent acetylation by acetic anhydride are discussed. And also the discovery of a new empirical equation instead of the traditional ECN or PN for the identification of molecular species of lecithin is discussed.

Table I-1. Fish examined

Species	Mean body length and weight	Locality of catch	Date of catch
Chum salmon (Summer)* <i>Oncorhynchus keta</i>	65 cm, 3.5 kg, (1)**	The offing of Akkeshi, Hokkaido	June 1980
Chum salmon (Fall)* <i>Oncorhynchus keta</i>	73 cm, 4.5 kg, (1)	The Moheji River, Hokkaido	Nov. 1981
Big-eyed tuna <i>Parathunnus obesus</i>	110 cm, 20 kg, (1)	Purchased from the Market.	—
Alaska pollack <i>Theragra chalcogramma</i>	44 cm, 610 g, (10)	The Uchiura Bay, Hokkaido	Dec. 1981
Carp <i>Cyprinus carpio</i>	23 cm, 175 g, (5)	Cultured	Sep. 1980

* Male. ** Nos. of individual used.

Section 1. Experimental

Preparation of Lecithin

Total lipids were obtained from the fish muscle tabulated in Table I-1, according to the method of Bligh & Dyer. Soybean lecithin was purchased from Wako Pure Chemical Industries, Ltd., Osaka, and egg yolk lecithin was kindly supplied by Asahi Chemical Industry Ltd., Tokyo. These total lipid and crude lecithin were subjected to a column chromatography which has been successfully done by Lands *et al.*²⁶⁾, namely, aliquot amount of total lipid was dissolved into double volume of diethyl ether/ethanol (9 : 1, v/v) and then applied to the silica gel column. And elutions were done through diethyl ether/ethanol (9 : 1, v/v), diethyl ether/ethanol (1 : 1, v/v), ethanol/methanol (9 : 1, v/v) and finally by 100% methanol. The 100% methanol fraction was collected with a fraction collector, monitored by TLC, and lecithin of more than 95% purity was collected.

Purification of Diglyceride Acetate from Lecithin

Pure lecithin was hydrolyzed with phospholipase C (*Clostridium perfringence*, P-L Biochemical Inc., Milwaukee), according to the method of Renkonen²⁷⁾. It was done in the following manner. First, 50 to 100 mg of lecithin was dissolved into 10 to 15 ml of diethyl ether. Then, 10 to 15 ml of 1 molar Tris buffer (pH 7.3) including calcium chloride with 5 mg of phospholipase C was added to the ether solution. The head space gas of the container was filled with nitrogen gas and the hydrolysis of lecithin was continued for four hours under room temperature. The hydrolysate was washed several times with water and diglyceride was purified by a preparative TLC from this hydrolysate. The developing solvent was n-hexane/diethyl ether (1 : 1, v/v).

Acetylation was performed by adding an appropriate amount of acetic anhydride to the solution of diglyceride in pyridine, and by standing it for 12 hours at room temperature²⁸⁾. The resulting diglyceride acetates were purified by the method of preparative TLC by using the solvent n-hexane/diethyl ether (75 : 25, v/v). Finally, they were filtered through a 0.45 μ type FP-45 Fluoropore filter (Sumitomo Electric Industry, Ltd., Osaka) and subjected to HPLC.

HPLC Fractionation of the Molecular Species of Diglyceride Acetate Derived from Lecithin

The diglyceride acetates were fractionated into major molecular species on twin 8 \times 250 mm LiChrosorb RP-18 (Merck, West Germany) columns which were connected in tandem. A Hitachi Liquid Chromatograph Model 638-50 (Hitachi Ltd., Tokyo) equipped with a Shodex RI detector Model SE-11 (Showa Denko Ltd., Tokyo) was used. The eluting solvent used was isopropanol/acetone/methanol/acetonitrile (1 : 1 : 3 : 4, v/v). Diglyceride acetates were dissolved into five volumes of tetrahydrofuran, and 25 μ l of these solutions were applied to the column under room temperature (lower the better) and at a flow rate of 1.5 ml/min.

Identification of Molecular Species of Each Peak on HPLC

Peaks on HPLC chromatograms were numbered in sequence of elution. The fatty acid composition of each collected predominant peak was analyzed by gas chromatography. The analytical conditions for fatty acids were as follows:

Gas chromatograph: Hitachi 063, Column: Unisole 3000 (Gasukuro Kōgyō Ltd., Tokyo), Glass column 0.2×200 cm, Column temp.: 220°C , Detector: FID, Detector temp.: 250°C , Injection temp.: 280°C , Carrier gas: N_2 , Flow rate: 20 ml/min.

Methyl esters of fatty acids were prepared according to the method of Christopher and Glass described by Prevot and Mordret²⁹. An aliquot amount (less than 20 mg) of lipid was dissolved in 1 ml n-hexane and 0.2 ml of methanolic 2N-NaOH solution was added. After shaking this mixture, it was stand for 20 seconds under 50°C and then 0.2 ml of methanolic 2N-HCl solution was added. The n-hexane layer was collected and then concentrated. Methyl esters prepared as described above were subjected to a GLC.

The small peaks which have critical pairs were first subjected to Ag^+ -TLC. The developing solvent used was benzene/diethyl ether (4:1, v/v)³⁰. The band obtained by Ag^+ -TLC were then eluted with diethyl ether containing dotriacontane which was used as an internal standard, and then applied to fatty acid analysis and total acyl carbon number analysis. The analytical conditions for total acyl carbon number analysis were as follows:

Gas chromatograph: Hitachi 063, Column: OV-101 (Gasukuro Kōgyō Ltd., Tokyo), Steel column 0.3×50 cm, Column temp.: $300\sim 330^{\circ}\text{C}$, programed as $1^{\circ}\text{C}/\text{min}$, Detector: FID, Detector temp.: 340°C , Injection temp.: 345°C , Carrier gas: N_2 , Flow rate: 60 ml/min.

Hydrolysis of Diglyceride Acetate Derived from Lecithin by Pancreatic Lipase

Fraction of the molecular species of 16:0 in position 1 and 22:6 in position 2, that is, (16:0) (22:6) was collected by HPLC. This lipid (less than 5 mg) was then suspended by shaking vigorously in a mixture of 1 molar Tris-HCl buffer, pH 8 (1 ml), 2.2% calcium chloride (0.1 ml), and 0.05% sodium taurocholate (0.25 ml) at 40°C for 1 min. Then, 40 mg of pancreatic lipase (Calbiochem, San Diego, Calif. 92112) was added to the mixture and the reaction was processed for 4 min at 40°C by shaking it vigorously. The reaction was stopped by adding 1 ml of ethanol and 1 ml of 6N-HCl. The hydrolysate was extracted with diethyl ether and purified by using a preparative TLC with n-hexane/diethyl ether/formic acid (40:10:1, v/v) as developing solvent. These procedures were the modified form of the experiment done by Kosugi *et al*³¹.

Section 2. Results

Figure I-1 shows the comparison of separation on HPLC by the differences in the molecular form of the molecular species which has the same acyl combination. Examples here are of soybean lecithin:

A: Intact lecithin,

Developing solvent: methanol/water (95:5, v/v)

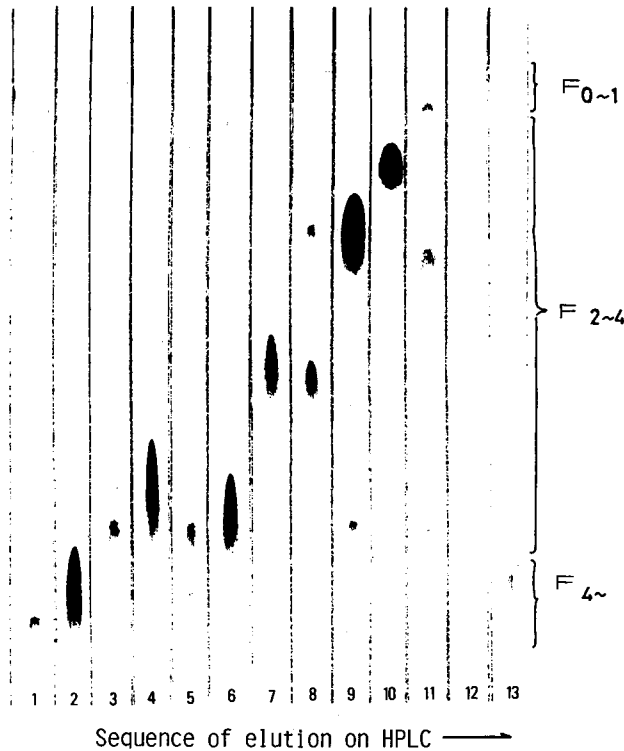

F : Number of double bonds.

Developing solvent : benzene/diethyl ether (4:1, v/v)

Fig. I-2. Ag^+ -TLC of diglyceride acetate derived from soybean lecithin separated by HPLC.

of this type of column.

Figures I-3~5 show chromatograms of diglyceride acetates derived from several kinds of lecithin sources on HPLC. Chromatography was regularly completed in about two hours. The acyl combination of each predominant peak collected was easily determined by fatty acid analysis, as shown in Table I-2. This table shows the results on big-eyed tuna lecithin as an example. Peak number 7 in Fig. I-5E is obviously ascribed to the diglyceride acetate composed of 16:0 and 22:6. It is considered that 22:6 is bound in position 2 of the molecule since this peak is the most predominant, and it is said that highly unsaturated fatty acids such as 20:5 or 22:6 are usually dominantly bound in position 2^{1,32-36}. In addition, after pancreatic lipase hydrolysis, only a trace amount of 22:6 was detected in the free fatty acid fraction (this fraction represents the fatty acid in position 1), although more than 70% of the lipid was hydrolyzed (determined by a densitometric method). Peak number 6 has the same combination as that in peak number 7, whereas (18:1) (20:5) is considered as contaminants of peak number 5. Nevertheless in this case, 22:6 is considered to be bound in position 1 in the molecule. Peak number 5 has

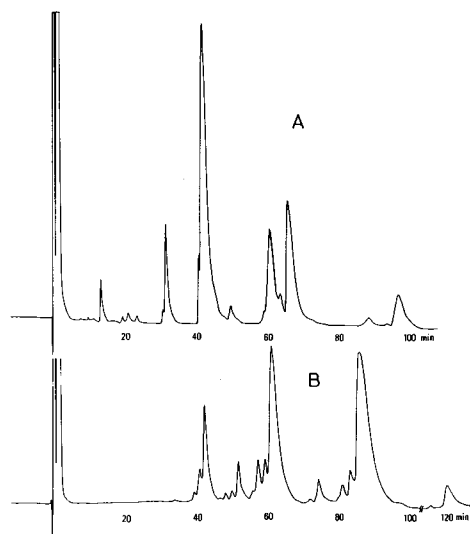
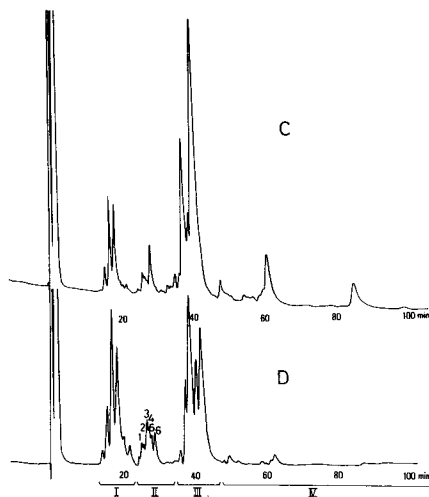

Fig. I-3. HPLC chromatograms of soybean and egg yolk lecithin.
A: Soybean B: Egg yolk



I: Molecular species composed of highly unsaturated fatty acids such as (20:5)(20:5), (20:5)(22:6) and (22:6)(22:6).
III: Molecular species composed of generally found fatty acids such as 16:0 or 18:1 with combinations of 20:5 or 22:6, that is, (16:0)(20:5), (16:0)(22:6), (18:1)(20:5) and (18:1)(22:6).
II & IV: Others.

Fig. I-4. HPLC chromatograms of chum salmon muscle lecithin.
C: Captured in summer D: Captured in fall

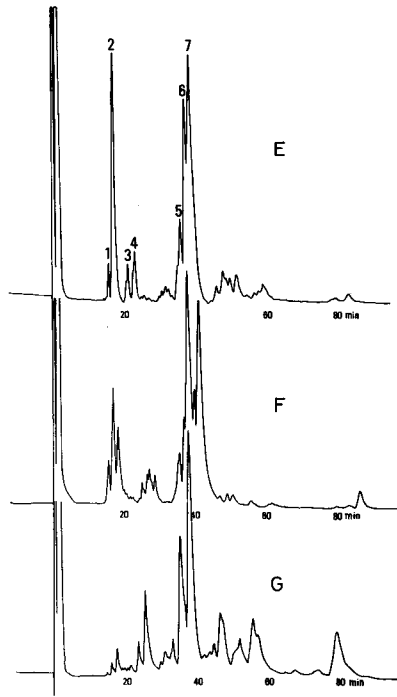

Fig. I-5. HPLC chromatograms of big-eyed tuna, Alaska pollack and carp muscle lecithin.
 E : Big-eyed tuna F : Alaska pollack G : Carp

Table I-2. Determination of molecular species of major component*

Peak number / Fatty acid	5	6	7
15 : 0			trace
16 : 0	25.6	48.4	53.8
17 : 0			trace
18 : 1	25.9	4.1	trace
20 : 4			trace
20 : 5	23.3	3.7	trace
22 : 4			trace
22 : 6	25.1	43.8	46.2
Molecular species	$\left \begin{array}{c} 18 : 1 \\ 20 : 5 \end{array} \right $ $\left(\begin{array}{c} 22 : 6 \\ 16 : 0 \end{array} \right)$	$\left \begin{array}{c} 22 : 6 \\ 16 : 0 \end{array} \right $	$\left \begin{array}{c} 16 : 0 \\ 22 : 6 \end{array} \right $

* Example of big-eyed tuna in Fig. I-5E.

Table I-3. Determination of molecular species of minor component*

Peak number Fatty acid	1	2	3	4	5	6
14:0			21.3	30.6	34.6	44.6
16:1	53.0	47.7	28.3	19.0	19.6	9.2
20:5	47.0	52.3	50.4	36.2	15.6	8.3
22:6				14.2	30.2	37.9
Carbon number**						
34			42.6	63.3	32.2	10.8
36	95.0<	90.0	57.4	5.7	41.7	89.2
38		10.0		31.0	26.1	
Carbon number**						
34			$\begin{matrix} 20:5 \\ 14:0 \end{matrix}$ 42.6	$\begin{matrix} 14:0 \\ 20:5 \end{matrix}$ 63.3	$\begin{matrix} 14:0 \\ 20:5 \end{matrix}$ 32.2	$\begin{matrix} 14:0 \\ 20:5 \end{matrix}$ 10.8
36	$\begin{matrix} 20:5 \\ 16:1 \end{matrix}$ 95.0<	$\begin{matrix} 16:1 \\ 20:5 \end{matrix}$ 90.0	$\begin{matrix} 16:1 \\ 20:5 \end{matrix}$ 57.4	$\begin{matrix} 16:1 \\ 20:5 \end{matrix}$ 5.7	$\begin{matrix} 22:6 \\ 14:0 \end{matrix}$ 41.7	$\begin{matrix} 14:0 \\ 22:6 \end{matrix}$ 89.2
38				$\begin{matrix} 22:6 \\ 16:1 \end{matrix}$ 31.0	$\begin{matrix} 16:1 \\ 22:6 \end{matrix}$ 26.1	

in relative %

* Example of chum salmon (Fall) in Fig. I-4D. ** Total acyl carbon number.

an almost even amount of fatty acids of 16:0, 18:1, 20:5 and 22:6. Among these fatty acids, 16:0 as well as 22:6 are regarded as contaminants from peak number 6, considering that peak number 6 is larger than peak number 5. It is concluded that peak number 5 is the combination of 18:1 and 20:5. Molecular species from other biological sources were also determined in the same manner. The small peaks which have critical pairs were first subjected to Ag^+ -TLC and separated according to their degree of unsaturation. In most of the small peaks in the first half of the HPLC chromatograms of fish lecithin, only one band appeared on Ag^+ -TLC plate. The complex combinations of molecular species were identified in the following manner. An example of determination of molecular species in the small peaks with critical pairs appeared in the first half of the HPLC chromatogram of chum salmon (captured in fall) is shown in Table I-3 (also see Fig. I-4D). Small peak number 1 is obviously a combination of 20:5 and 16:1. Small peak number 2 is also a combination of 20:5 and 16:1 with 10% unidentified contaminants. The differences in retention time on HPLC between these two peaks is attributed to the differences in binding position of the fatty acid. It is considered that small peak number 1 has 20:5 in position 1, whereas small peak number 2 has it in position 2 in the molecule, since molecular species which have a highly unsaturated fatty acid in position 2 are likely to elute later than the one which has the same fatty acid in position 1. Small peak number 3 is a combination of 20:5 in position 1 and 14:0 in position 2, and also 16:1 in position 1 and 20:5 in position 2 since this peak is composed of two combinations of total acyl carbon numbers of 34 and 36, respectively. However, the latter molecular species, i.e. (16:1)(20:5), are considered to be contaminants from the previous peak. From the fatty acid composition and total acyl carbon number, three molecular species are presented in small peak number 4, i.e. combination of 14:0 in position 1 and 20:5 in position 2 for 63.3%; combination of 16:1 in position 1 and 20:5 in position 2 for 5.7%; and combination of 22:6 in position 1 and 16:1 in position 2 for 31.0%. Among these molecular species, (16:1)(20:5) can be considered as contaminant from the two previous peaks. In small peak number 5, three molecular species, i.e. 14:0 in position 1 and 20:5 in position 2; 22:6 in position 1 and 14:0 in position 2; and 16:1 in position 1 and 22:6 in position 2 is identified in the same manner as that in small peak number 4. In this case, molecular species of (14:0)(20:5) is considered to be a contaminant from the previous peak. In the case of small peak number 6, molecular species of 14:0 in position 1 and 20:5 in position 2 are considered to be the contaminants from the previous peak. By analyzing the data in this way, molecular species of all other small peaks were identified.

The relative retention times (RRTs) of all peaks were determined by dividing the retention time of each peak by the retention time of (16:0)(22:6). In the case of soybean lecithin, (16:0)(18:2) was used as a reference peak and the RRT were recalculated against (16:0)(22:6) by using the RRT data in egg yolk lecithin. The RRT of each molecular species is summarized in Tables I-4~7.

Table I-4. Relation between relative retention time on HPLC and molecular species of soybean lecithin.

PN	MS	Rt	RRT*
26	18 : 2 18 : 3	27.6	70.4
28	18 : 2 18 : 2	37.6	95.8
"	18 : 1 18 : 3	39.2	99.9
"	16 : 0 18 : 3	42.0	107.1
30	18 : 1 18 : 2	51.4	131.0
"	16 : 0 18 : 2	55.2	140.7
"	18 : 0 18 : 3	60.0	152.9
31	17 : 0 18 : 2	62.8	160.1
32	18 : 1 18 : 1	73.8	188.1
"	20 : 1 18 : 2	"	"
"	16 : 0 18 : 1	79.6	202.9
"	18 : 0 18 : 2	"	"
"	16 : 0 16 : 0	83.6	213.0
34	18 : 0 18 : 1	113.2	288.6
"	18 : 2 20 : 0	"	"

Abbreviations :

PN : Partition number

MS : Molecular species

RRT : Relative retention time

Rt : Retention time

* | 16 : 0 |
| 22 : 6 | is used as the reference peak.

Table I-5. Relation between relative retention time on HPLC and molecular species of egg yolk lecithin

PN	MS	Rt	RRT*
28	16:1 18:2	41.2	100.0
"	18:2 18:2	"	"
"	14:0 18:2	"	"
26	16:0 22:6	"	"
28	16:0 18:3	47.0	114.1
"	18:1 20:4	"	"
"	16:0 20:4	50.4	122.2
30	16:0 22:4	54.4	132.0
"	16:1 18:1	55.6	134.9
"	18:1 18:2	"	"
"	16:0 18:2	59.2	143.7
28	18:0 22:6	"	"
31	15:0 18:1	72.4	175.7
"	16:0 17:1	"	"
"	17:0 18:2	"	"
30	18:0 20:4	"	"
32	18:1 18:1	79.0	191.7
"	18:0 22:4	"	"
"	16:0 18:1	83.6	202.9
"	18:0 18:2	"	"
34	18:0 18:1	121.8	295.1

Abbreviations:

PN : Partition number

MS : Molecular species

RRT : Relative retention time

Rt : Retention time

* $\left| \begin{array}{l} 16:0 \\ 22:6 \end{array} \right|$ is used as the reference peak.

Table I-6. Relation between relative retention time on HPLC and main molecular species of fish muscle lecithin

Chum salmon (Summer)		Chum salmon (Fall)		Big-eyed tuna		Alaska pollack		Carp	
MS	PN/RRT*	MS	PN/RRT*	MS	PN/RRT*	MS	PN/RRT*	MS	PN/RRT*
20 : 5	20	20 : 5	20	20 : 5	20	20 : 5	20	20 : 5	20
20 : 5	37.3	20 : 5	37.5	22 : 6	41.2	20 : 5	37.2	22 : 6	42.5
20 : 5	20	20 : 5	20	22 : 6	20	20 : 5	20	22 : 6	20
22 : 6	40.7	22 : 6	40.4	22 : 6	44.6	22 : 6	40.4	22 : 6	46.2
22 : 6	20	22 : 6	20	20 : 4	22	22 : 6	20	16 : 1	24
22 : 6	44.2	22 : 6	44.1	22 : 6	55.2	22 : 6	44.3	20 : 5	62.5
14 : 0	24	18 : 1	26	22 : 5	22	18 : 1	26	18 : 2	24
22 : 6	69.7	20 : 5	87.0	20 : 5	55.2	20 : 5	86.7	20 : 5	62.5
16 : 0	26	20 : 5	26	22 : 5	22	20 : 5	26	16 : 1	24
20 : 5	92.2	16 : 0	89.5	22 : 6	60.5	16 : 0	89.8	22 : 6	67.7
18 : 1	26	16 : 0	26	18 : 1	26	22 : 6	26	18 : 2	24
22 : 6	92.2	20 : 5	91.9	22 : 6	93.5	18 : 1	89.8	22 : 6	67.7
22 : 6	26	18 : 1	26	16 : 0	26	16 : 0	26	14 : 0	24
16 : 0	97.1	22 : 6	91.9	20 : 5	93.5	20 : 5	92.0	22 : 6	67.7
16 : 0	26	22 : 6	26	22 : 6	26	18 : 1	26	18 : 1	26
22 : 6	100.0	16 : 0	96.7	16 : 0	96.8	22 : 6	92.0	20 : 5	88.3
		16 : 0	26	16 : 0	26	22 : 6	26	16 : 0	26
		22 : 6	100.0	22 : 6	100.0	16 : 0	97.1	20 : 5	93.7
				16 : 0	28	16 : 0	26	18 : 1	26
				22 : 5	134.9	22 : 6	100.0	22 : 6	93.7
						16 : 0	32	16 : 0	26
						18 : 1	216.6	22 : 6	100.0
						14 : 0	32	16 : 0	28
						20 : 1	216.6	20 : 4	124.0

Abbreviations :

PN : Partition number. MS : Molecular species. RRT : Relative retention time.

* $\begin{matrix} | 16 : 0 | \\ | 22 : 6 | \end{matrix}$ is used as the reference peak.

Table I-7. Relation between relative retention time on HPLC and the appreciable amount molecular species of fish muscle lecithin

Chum salmon (Summer)		Chum salmon (Fall)		Big-eyed tuna		Alaska pollack		Carp	
MS	PN/RRT*	MS	PN/RRT*	MS	PN/RRT*	MS	PN/RRT*	MS	PN/RRT*
20:4	22	18:3	22	22:6	24	16:1	24	18:3	22
22:6	50.6	22:6	48.7	16:1	65.0	20:5	61.0	22:6	50.7
22:5	22	20:4	22	18:2	24	18:2	24	20:4	22
20:5	50.6	22:6	48.7	22:6	66.9	20:5	61.0	20:5	52.3
22:5	22	22:5	22	14:0	24	14:0	24	22:5	22
22:6	52.8	20:5	48.7	22:6	71.1	20:5	64.2	22:6	54.5
16:1	24	20:5	24	22:4	24	16:1	24	20:4	22
20:5	60.8	16:1	59.1	22:6	71.1	22:6	65.9	22:6	56.4
14:0	24	20:5	24	16:1	26	18:2	24	16:1	26
20:5	64.8	18:2	59.1	20:4	71.1	22:6	65.9	22:5	79.4
16:1	24	16:1	24	20:4	24	14:0	24	18:2	26
22:6	65.8	20:5	60.8	22:5	74.0	22:6	69.9	22:5	79.4
22:6	24	18:2	24	22:6	25	22:5	28	15:0	25
14:0	67.4	20:5	60.8	17:1	78.4	16:0	115.7	22:6	79.4
15:0	25	20:5	24	22:5	24	16:0	28	17:1	25
20:5	77.8	14:0	62.2	22:5	78.4	20:4	115.7	22:6	79.4
17:1	25	14:0	24	17:2	25	16:0	28	16:1	26
22:6	82.3	20:5	64.2	20:4	78.4	22:5	120.3	20:4	82.7
14:0	26	22:6	24	17:2	25	20:1	28	18:2	26
22:5	82.3	16:1	64.2	22:5	78.5	20:5	125.0	20:4	82.7
15:0	25	16:1	24	17:1	25	18:0	28	18:1	28
22:6	84.4	22:6	67.1	22:6	82.7	20:5	137.5	22:5	111.7
20:5	26	22:6	24	15:0	25	20:1	28	16:0	28
18:1	87.2	14:0	67.1	22:6	84.7	22:6	137.5	16:2	111.7

18 : 1	26	14 : 0	24	20 : 5	26	18 : 1	30	18 : 1	28
20 : 5	90.2	22 : 6	69.5	18 : 1	84.7	16 : 1	137.5	20 : 4	115.8
20 : 5	26	16 : 1	26	18 : 1	26	18 : 1	30	16 : 0	28
16 : 0	90.2	22 : 5	77.8	20 : 5	88.2	18 : 2	137.5	22 : 5	119.3
22 : 6	26	15 : 0	25	22 : 6	26	14 : 0	30	16 : 0	30
18 : 1	90.2	20 : 5	77.8	18 : 1	91.3	18 : 1	150.0	22 : 4	133.8
16 : 0	28	17 : 1	25	20 : 5	26	16 : 0	30	20 : 1	28
22 : 5	121.9	22 : 6	77.8	16 : 0	91.3	16 : 1	150.0	22 : 6	133.8
16 : 0	28	20 : 5	26	20 : 4	28	16 : 0	30	18 : 1	30
20 : 4	126.6	18 : 1	82.2	16 : 0	116.7	18 : 2	150.0	16 : 1	138.4
17 : 0	27	22 : 5	28	17 : 0	27	18 : 0	28	18 : 1	30
22 : 6	126.6	16 : 0	116.6	22 : 6	116.7	22 : 6	150.0	18 : 2	138.4
20 : 1	28	16 : 0	28	18 : 1	28	18 : 1	32	16 : 0	30
20 : 5	126.6	22 : 5	119.9	22 : 5	116.7	16 : 0	207.4	18 : 2	148.4
20 : 1	28	16 : 0	28	16 : 0	28	20 : 1	32	16 : 0	30
22 : 6	140.6	20 : 4	124.6	20 : 4	124.6	14 : 0	207.4	16 : 1	148.4
18 : 0	28	20 : 1	28	22 : 5	28	16 : 0	34	18 : 0	28
20 : 5	140.6	20 : 5	124.6	16 : 0	130.0	20 : 1	301.9	22 : 6	148.4
18 : 1	30	18 : 0	28	22 : 6	28	18 : 0	34	18 : 0	30
16 : 1	143.6	20 : 5	133.3	18 : 0	143.2	18 : 1	301.9	20 : 4	179.4
18 : 0	28	18 : 1	30	18 : 0	28			18 : 1	32
22 : 6	152.5	16 : 1	137.2	22 : 6	148.1			18 : 1	195.3
14 : 0	30	14 : 0	30	18 : 1	32			16 : 0	32
18 : 1	152.5	18 : 1	142.9	18 : 1	189.6			18 : 1	210.1
16 : 0	30	16 : 0	30	18 : 1	32				
16 : 1	152.5	16 : 1	142.9	16 : 0	206.1				
24 : 1	32			16 : 0	32				
20 : 5	265.7			18 : 1	215.5				

Abbreviations :

PN : Partition number. MS : Molecular species. RRT : Relative retention time.

* $\left| \begin{array}{l} 16 : 0 \\ 22 : 6 \end{array} \right|$ is used as the reference peak.

1985]

TAKAHASHI : Identification of Lipid Molecular Species

Section 3. Discussion

We have plotted the RRT of each molecular species semilogarithmically against the partition number (PN) defined as $PN = CN - 2 \times DB$ where CN is the total acyl carbon number and DB is the total double bonds since PN is proportional to the logarithm of RRT ³⁷⁾. A general expression for this can be written as:

$$PN \propto \log(RRT) \quad (1)$$

After plotting the RRT of each molecular species semilogarithmically, a similar correlation was obtained, that is:

$$PN \propto \log(RRT) + \Delta Q \quad (2)$$

(2) is similar to (1), and if we formulate (2) into an equation:

$$PN = P \cdot \log(RRT) + \Delta Q \quad (3)$$

where P becomes the slope of the oblique line, and ΔQ becomes the intersection on the ordinate. This equation (3) suggests that PN is not only a function of RRT alone, but also a function including ΔQ .

Back to the definition of the PN , that is, $PN = CN - 2 \times DB$, the left member in (3) can be changed as:

$$CN - 2 \times DB = P \cdot \log(RRT) + \Delta Q \quad (4)$$

So, RRT can be expressed as follows:

$$RRT = 10^{\frac{CN - 2 \times DB - \Delta Q}{P}} \quad (5)$$

If we put ΔQ_1 as $Q_1 + \alpha$, equation (5) may be written as:

$$RRT = 10^{\frac{CN - 2 \times DB - (Q_1 + \alpha)}{P}} \quad (Q_1 \text{ is a minimum of } \Delta Q) \quad (6)$$

where P and Q are invariables and α is a variable range of Q_1 . By letting CN and DB be invariables, RRT becomes a function of α which is:

$$RRT = f(\alpha) \quad (7)$$

Back to equation (4), by putting ΔQ as $Q_1 + \alpha$, the following equation can be obtained:

$$CN - 2 \times DB = P \cdot \log(RRT) + Q_1 + \alpha \quad (4')$$

If we let DB be invariable and rearrange the expression for CN , (4') will become:

$$CN = P \cdot \log(RRT) + \alpha + Q_2 \quad (Q_2 = Q_1 + 2 \times DB) \quad (8)$$

On the other hand, if we let CN be invariable and rearrange the expression for DB , (4') will become:

$$DB = -\frac{P}{2} \log(RRT) - \frac{\alpha}{2} + Q_3 \quad (Q_3 = -\frac{1}{2} (Q_1 - CN)) \quad (9)$$

These two functions, i.e. (8) and (9) have a deviation which are α for the former and $-\alpha/2$ for the latter. Alfa is considered to be a factor that has a small but significant effect on RRT , and it may be due to the positional isomers such as between 1 and 2 positions in the molecule, or by the large differences in number of double bonds between the two acyl group in the molecule. This leads us to the model of a matrix since it is convenient to distinguish the positional isomers or the bias in the number of double bonds between the two acyl groups in the molecule.

So in order to simplify the equation, we can induce the following equations from (8) and (9) respectively under the conditions of:

$$CN' = \begin{vmatrix} x & d_1 \\ c_2 & d_2 \end{vmatrix} \quad (c_2, d_1 \text{ and } d_2 \text{ are invariables})$$

$$DB' = \begin{vmatrix} c_1 & y \\ c_2 & d_2 \end{vmatrix} \quad (c_1, c_2 \text{ and } d_2 \text{ are invariables})$$

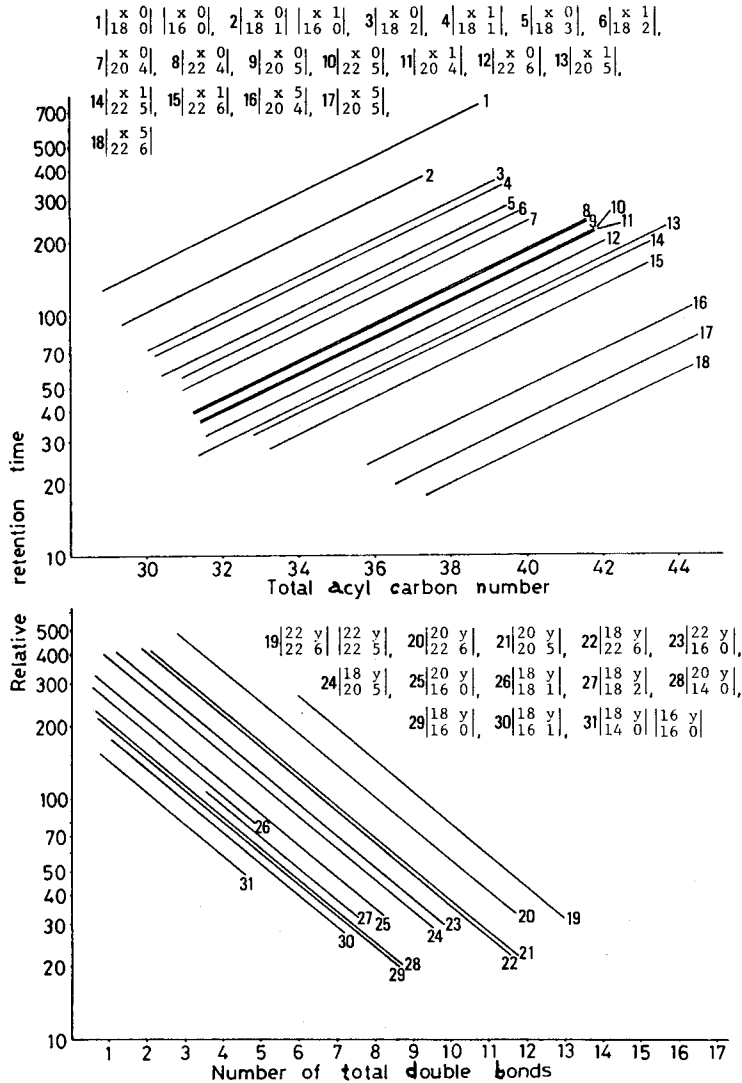

Fig. I-6. Relation between relative retention time and total acyl carbon number and relation between relative retention time and total double bonds of lecithin on HPLC.

$$CN' = P_1 \cdot \log(RRT) + q_1 \quad (8')$$

$$DB' = P_2 \cdot \log(RRT) + q_2 \quad (9')$$

by analyzing the *RRT* data of each molecular species.

After plotting the *RRT* of each molecular species from the source examined against the total acyl carbon number or the number of total double bonds of each molecular species, the *RRT* plots of molecular species laid almost on a straight line by giving a variable integer *x* for the carbon number and a variable integer *y* for the number of double bonds of each acyl group in the molecular species, when we express the molecular species in matrix form. The oblique line is almost parallel to each other as shown in Fig. I-6. By applying these correlations between the *RRT* and the corresponding molecular species under the condition of matrix for the determination of molecular species, it is suggested that an unidentified molecular species can be predicted from *RRT* on HPLC even if it has the most complicated composition of molecular species such as fish muscle lecithin.

Another method for HPLC analysis of phospholipid molecular species was published by Patton *et al.*¹⁹⁾ To our surprise, the sequence of each molecular species in elution on HPLC, when the *RRT*'s are plotted against the total acyl carbon number from our biological material, are the same as common molecular species of rat liver which was analyzed by Patton *et al.*¹⁹⁾ despite the fact that the analytical conditions are significantly different. This suggests that, although there are differences in retention time or in *RRT* among the different conditions on HPLC, the sequence in elution of each molecular species might be unchangeable. This leads us to a conclusion that in HPLC, the sequence in elution might be controlled by a fixed correlation, that is matrix relation*. By accepting this idea, we can expand this matrix model to triglycerides. Details will be discussed in the next chapter.

CHAPTER II

A Novel Approach for the Identification of Triglyceride Molecular Species on Reversed-Phase High Performance Liquid Chromatography

In chapter I, two rules in the elution of diglyceride acetate derived from lecithin on HPLC were discovered, that is :

$$CN = P_1 \cdot \log(RRT) + Q_1 \quad CN = \begin{vmatrix} x & d_1 \\ c_2 & d_2 \end{vmatrix} \quad (1)$$

$$DB = P_2 \cdot \log(RRT) + Q_2 \quad DB = \begin{vmatrix} c_1 & y \\ c_2 & d_2 \end{vmatrix} \quad (2)$$

where *P* is the slope and *Q* is the intersection on the ordinate of the semilogarithmic plots of the *RRT*'s of molecular species against *CN* or *DB*. *c* and *d* are acyl carbon number and number of double bonds in each acyl group, respectively. *x* and *y* are variables of acyl carbon number and number of double bonds, respectively.

* This matrix expression is for the ease of expressing the invariables and variables in the acyl groups in the lipid molecule. It does not follow the mathematical operations.

The structure of diglyceride acetate is:

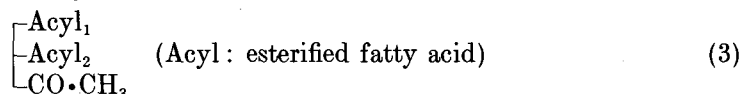

And the structure of triglyceride is:



The difference between (3) and (4) is at position 3 in the molecule. But $\text{CO} \cdot \text{CH}_3$ in (3) can also be considered as the shortest form of acyl group.

So:

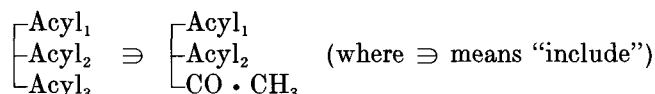

therefore, (1) and (2) can be rewritten as:

$$CN = P_1 \cdot \log(RRT) + Q_1 \quad CN = \begin{vmatrix} x & d_1 \\ c_2 & d_2 \\ 2 & 0 \end{vmatrix} \quad (1')$$

$$DB = P_2 \cdot \log(RRT) + Q_2 \quad DB = \begin{vmatrix} c_1 & y \\ c_2 & d_2 \\ 2 & 0 \end{vmatrix} \quad (2')$$

since (2, 0) in position 3 exhibits the acyl (acetyl) group which has two carbons and no double bond. So we can conclude that (1) and (2) are members of the general

rule for triglycerides under the condition of $\begin{vmatrix} x & d_1 \\ c_2 & d_2 \\ 2 & 0 \end{vmatrix}$ or $\begin{vmatrix} c_1 & y \\ c_2 & d_2 \\ 2 & 0 \end{vmatrix}$. By adapting the general expressions to triglyceride, the following equations can finally be obtained.

$$CN = P_1 \cdot \log(RRT) + Q_1 \quad CN = \begin{vmatrix} x & d_1 \\ c_2 & d_2 \\ c_3 & d_3 \end{vmatrix} \quad (5)$$

$$DB = P_2 \cdot \log(RRT) + Q_2 \quad DB = \begin{vmatrix} c_1 & y \\ c_2 & d_2 \\ c_3 & d_3 \end{vmatrix} \quad (6)$$

In this chapter, the theory that has proved mathematically, is verified by the actual experiment.

Section 1. Experimental

Preparation of Triglyceride

Linseed oil and olive oil were purchased from Wako Pure Chemical Industries, Ltd., Osaka. Rapeseed oil was obtained from a commercial source. Cacao butter was supplied by Yunokawa Seiyaku Co. Ltd., Hakodate, Hokkaido, Japan. "Ogonori" (*Gracilaria verrucosa*) was collected at the shore of Taisei-chō, Hokkaido, Japan. Total lipid was extracted from "Ogonori" using chloroform/methanol (1 : 2,

v/v) with the use of an ultra-turrax for comminution.

Triglycerides from these oils were purified by a preparative TLC using n-hexane/diethyl ether (4 : 1, v/v) as the developing solvent.

HPLC Fractionation of Molecular Species of Triglyceride

The purified triglycerides were filtered through a $0.45\ \mu$ type FP-45 Fluoropore filter (Sumitomo Electric Industry, Ltd., Osaka) and subjected to HPLC. Separation of triglycerides by HPLC has been achieved on LiChrosorb RP-18 (Merck, West Germany) twin 8×250 mm columns. These columns were connected in tandem. The instruments used consisted of a Hitachi 638-50 Liquid Chromatograph (Hitachi Ltd., Tokyo) equipped with a Shodex SE-11 RI detector (Showa Denko Ltd., Tokyo). The eluting solvent used was acetone/acetonitrile (3 : 1, v/v). Triglycerides were dissolved in chloroform at $5\ \mu\text{g}/25\ \mu\text{l}$ and applied to the column under room temperature (20–22°C). The flow rate was 1.5 ml/min.

Identification of Molecular Species of Each Peak on HPLC

Peaks on HPLC chromatograms were numbered in sequence of elution. The fatty acid composition and the total acyl carbon number of each collected predominant peak was analyzed by GLC as previously shown in chapter I.

Section 2. Results

Figure II-1 shows chromatograms of triglycerides on HPLC. The acyl combination of each predominant peak collected was determined by fatty acid analysis

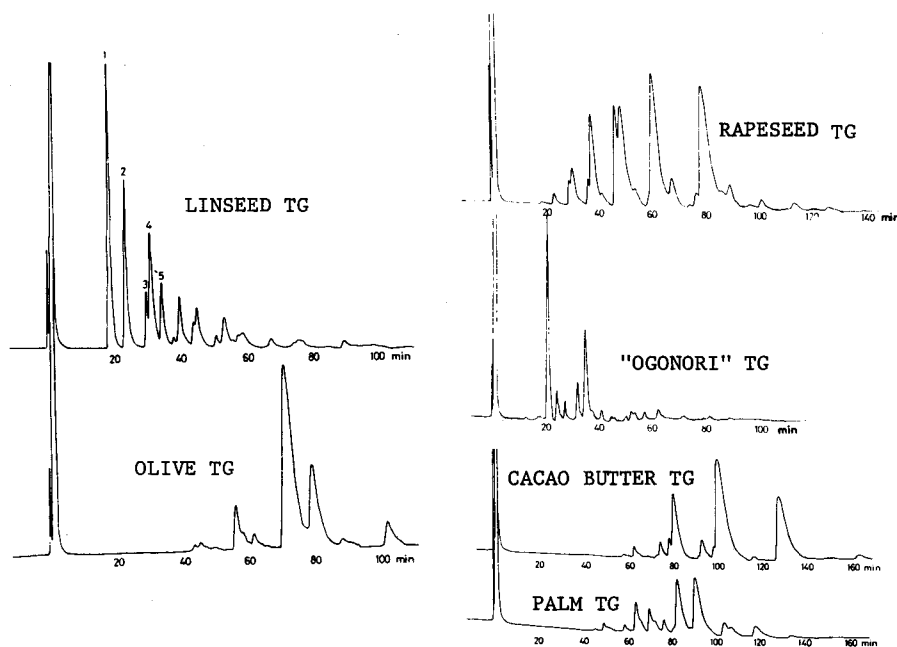

Fig. II-1. HPLC chromatograms of triglycerides from natural sources.

Table II-1. Determination of triglyceride molecular species*

	Peak number				
	1	2	3	4	5
Fatty acid					
16:0					29.6
18:1				28.9	3.7
18:2		33.4	63.2	9.7	1.1
18:3	98.0<	66.6	36.8	61.4	65.5
Carbon number**					
52					98.0<***
54	98.4***	98.3***	96.6***	96.8***	
Molecular species	18:3 18:3 18:3	18:3 18:3 18:2	18:3 18:2 18:2	18:3 18:3 18:1	16:0 18:3 18:3

in relative %

* Example of linseed oil. ** Total acyl carbon number. *** Percentage by weight.

and total acyl carbon number analysis as shown in Table II-1. This table shows the results on linseed oil in Fig. II-1 as an example. Peak number 1 in Fig. II-1 is triglyceride composed of 18:3 alone, i.e., (18:3, 18:3, 18:3) because over 98% of fatty acid of this fraction is 18:3, in addition, the total acyl carbon number of this peak is mostly 54. Peak number 2 is considered to be the combination of one mol of 18:2 and two mols of 18:3, that is, (18:2, 18:3, 18:3). This is supported by the data of total acyl carbon number of this fraction. Peak number 3 is mainly (18:3, 18:2, 18:2) for the same reasons in peak number 2. Peak number 4 is (18:1, 18:3, 18:3) with 4~10% contaminants because 9.7% of 18:2 is detected as overlaps from the previous peak. Peak number 5 has at least two contaminants, i.e. 18:1 and 18:2. This peak is concluded to be (16:0, 18:3, 18:3) from the data of total acyl carbon number. All other peaks were identified in the same manner.

The relative retention times (RRTs) of all peaks were determined by dividing the retention time of each peak by that of triolein. When the amount of triolein was very small and or the peak overlapped considerably, purified triolein was added to the sample as an internal standard. Predominant or reliable peaks were selected (Table II-2) to plot the RRTs of individual triglycerides on a semilogarithmic graph paper. Results are shown in Fig. II-2A. The RRTs were also calculated from the chromatograms in the reports of Perkins *et al.*^{11,38)} (see Table II-3 in the next section) and those of Merritt *et al.*³⁹⁾, and plotted on a semilogarithmic graph paper as shown in Fig. II-2B and Fig. II-2C, respectively. As it is clear from these figures, the sequence in elution might be controlled by a fixed correlation, that is, a matrix relation, though the analytical conditions are different among the three figures in Fig. II-2. If we express these by empirical equations, the two equations described previously (equations (5) and (6) in page 265) can be obtained.

In Fig. II-2, it is observed that even triglycerides from plant sources show

Table II-2. Relation between relative retention time

Repeseed oil		Linseed oil		Cacao butter	
RRT*	Molecular species	RRT*	Molecular species	RRT*	Molecular species
28.6	(18:3)×2(18:2)	22.5	(18:3)×3	91.2	(16:0)×2(18:2)
35.9	(18:2)×2(18:3)	28.6	(18:3)×2(18:2)	117.5	(16:0)×2(18:1)
37.5	(18:3)×2(18:1)	35.5	(18:2)×2(18:3)	136.2	(18:1)×2(18:0)
45.0	(18:2)×3	36.8	(18:3)×2(18:1)	143.7	(18:0)×2(18:2)
46.8	(18:1)(18:2)(18:3)	40.1	(18:3)×2(16:0)	146.8	(16:0)(18:0)(18:1)
58.4	(18:2)×2(18:1)	44.4	(18:2)×3	184.8	(18:0)×2(18:1)
61.0	(18:1)×2(18:3)	46.5	(18:1)(18:2)(18:3)	238.5	(18:0)(18:1)(20:0)
76.3	(18:1)×2(18:2)	51.0	(16:0)(18:2)(18:3)		
85.5	(16:0)(18:1)(18:2)	58.4	(18:2)×2(18:1)		
100.0	(18:1)×3	61.0	(18:1)×2(18:3)		
112.4	(18:1)×2(16:0)	76.6	(16:0)(18:1)(18:3)		
122.4	(18:1)(18:2)(22:1)	92.6	(16:0)(18:0)(18:3)		
128.3	(18:1)×2(20:1)	100.0	(18:1)×3		
143.9	(18:1)×2(18:0)				
160.0	(18:1)×2(22:1)				

* RRT: Relative retention time when (18:1)×3 is used as the reference peak.

complicated sets of oblique lines. This is due to the extreme increase in probability in combination of fatty acids. For example, if we have four kinds of fatty acids, there is a probability that diglyceride or lecithin might have a maximum of $4^2=16$ kinds of acyl combinations. But in case of triglycerides, this will drastically increase up to $4^3=64$ kinds of acyl combinations. More specifically, in case of fish lipid, for instance if we have ten kinds of fatty acids, there is a probability that diglyceride or lecithin might have a maximum of $10^2=100$ kinds of acyl combinations, while in case of triglyceride, $10^3=1000$ combinations might be possible. The author has tried to analyze the molecular species of triglycerides from fish muscle. But the theoretical plate of the HPLC column is still not enough to separate the very complicated combination of molecular species of triglyceride from marine sources. Recently, column packing with $3\ \mu\text{m}$ particles has been developed by Dong *et al.*⁴⁰⁾ for triglyceride analysis from vegetable sources. Though the life of this type of column packing is shorter than the conventional $5\text{-}\mu\text{m}$ particle type, it is expected to give a high resolution chromatograms.

Section 3. Discussion

The chromatograms of Perkins *et al.*^{11,38)} were used in this study. RRT's of each peak on their chromatograms were calculated by dividing the retention time of each peak by that of triolein. Multiple regression analysis⁴¹⁾ was performed against the RRT using a Personal computer Model PC-8001 (NEC, Tokyo).

Martin⁴²⁾ formulated the equations:

and molecular species of triglyceride from natural sources

Palm oil		Ogonori		Olive oil	
RRT*	Molecular species	RRT*	Molecular species	RRT*	Molecular species
62.3	(18:2)×2(16:0)	27.8	(20:4)×3	76.3	(18:1)×2(18:2)
74.7	(18:1)×2(18:2)	32.8	(20:4)×2(20:3)	100.0	(18:1)×3
83.6	(16:0)(18:1)(18:2)	37.0	(20:4)×2(14:0)	125.4	(16:0)×2(18:1)
92.1	(16:0)×2(18:2)	43.8	(20:4)×2(18:1)	144.8	(18:1)×2(18:0)
128.6	(16:0)×3	47.8	(20:4)×2(16:0)		

$$\frac{\Delta\mu_B}{R \cdot T} = \frac{\Delta\mu_A}{R \cdot T} + \frac{\Delta\mu_X}{R \cdot T}, \quad \ln\left(\frac{\alpha_B}{\alpha_A}\right) = \frac{\Delta\mu_X}{R \cdot T} \quad (1)$$

where A , B are members of a homologous series, differing by the functional group X , α is the partition coefficient, and $\Delta\mu_X$ is the difference in chemical potential of the group X in a polar or nonpolar phase of the chromatographic system. It follows that each functional group in the solute molecule contributes more or less independently to the differences in standard free energy of the solute between the two chromatographic phases. Thus in general, there is a linear relationship between $\ln \alpha$ or $\log \alpha$ and the number of functional groups in a homologous series. By

substituting A in Martin's⁴²⁾ equation with a triglyceride species $\begin{vmatrix} c_1 & d_1 \\ c_2 & d_2 \\ c_3 & d_3 \end{vmatrix}$ and B with

$\begin{vmatrix} c_1 + X & d_1 \\ c_2 & d_2 \\ c_3 & d_3 \end{vmatrix}$, or substitute A with $\begin{vmatrix} c_1 & d_1 \\ c_2 & d_2 \\ c_3 & d_3 \end{vmatrix}$ and B with $\begin{vmatrix} c_1 & d_1 + Y \\ c_2 & d_2 \\ c_3 & d_3 \end{vmatrix}$, then X and Y

will denote functional groups. In simple triglycerides, X corresponds to the $-\text{CH}_2-$ unit and Y corresponds to the $-\text{CH}=\text{CH}-$ unit. The chemical potential of the triglyceride molecule is principally affected by X or Y because an elongation of the hydrocarbon chain or an increase in the number of double bonds in the acyl group affects the RRT of each molecular species. Plots of (empirically determined) $\log(\text{RRT})$ against CN or DB on semilogarithmic paper draw ascending or descending

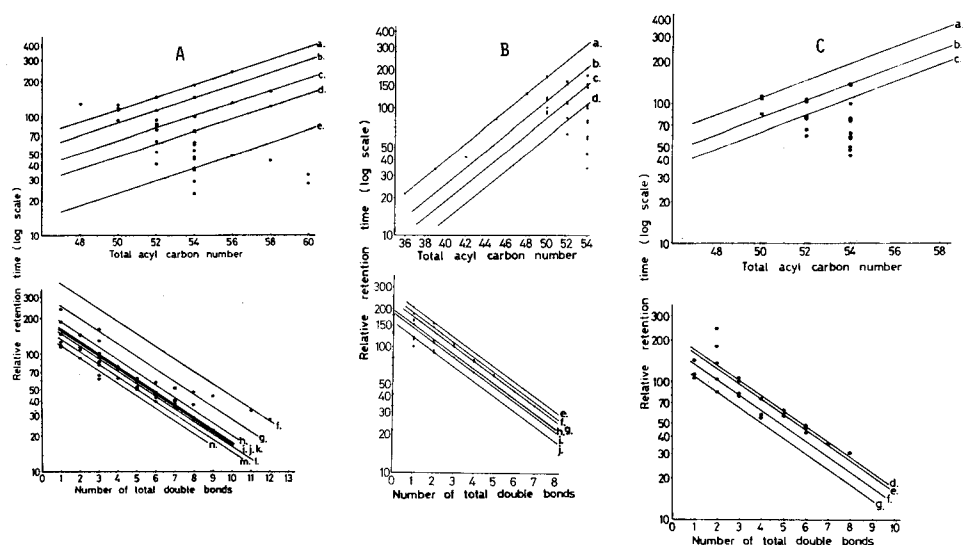

Fig. II-2. Relation between relative retention time and total acyl carbon number and relation between relative retention time and total double bonds of triglyceride on HPLC.

A: Plant sources in this study B: Data of E.G. Perkins *et al.* in *J. Am. Oil Chem. Soc.*, **58**, 867-872 (1981) and in *Lipids*, **17**, 460-463 (1982) C: Data of C. Merritt *et al.* in *J. Am. Oil Chem. Soc.*, **59**, 422-432 (1982).

(*x* and *y* are variables of acyl carbon number and number of double bonds respectively, for example, *x* can take 16, 18, 20, 22... and *y* can take 1, 2, 3, 4, 5...etc)

A	{	a.	$\begin{vmatrix} 18 & 0 \\ 18 & 1 \\ x & 0 \end{vmatrix}$	b.	$\begin{vmatrix} 18 & 1 \\ 18 & 1 \\ x & 0 \end{vmatrix}$	c.	$\begin{vmatrix} 18 & 1 \\ 18 & 1 \\ x & 1 \end{vmatrix}$	d.	$\begin{vmatrix} 18 & 1 \\ 18 & 2 \\ x & 1 \end{vmatrix}$	e.	$\begin{vmatrix} x & 0 \\ 20 & 4 \\ 20 & 4 \end{vmatrix}$	f.	$\begin{vmatrix} 20 & y \\ 20 & 4 \\ 20 & 4 \end{vmatrix}$
		g.	$\begin{vmatrix} 18 & y \\ 18 & 1 \\ 22 & 1 \end{vmatrix}$	h.	$\begin{vmatrix} 18 & 0 \\ 18 & 0 \\ 18 & y \end{vmatrix}$	i.	$\begin{vmatrix} 18 & 1 \\ 18 & 1 \\ 18 & y \end{vmatrix}$	j.	$\begin{vmatrix} 18 & 2 \\ 18 & 1 \\ 18 & y \end{vmatrix}$	k.	$\begin{vmatrix} 18 & 3 \\ 18 & 2 \\ 18 & y \end{vmatrix}$	l.	$\begin{vmatrix} 16 & 0 \\ 18 & 3 \\ 18 & y \end{vmatrix}$
	m.	$\begin{vmatrix} 16 & 0 \\ 18 & 2 \\ 18 & y \end{vmatrix}$	n.	$\begin{vmatrix} 16 & 0 \\ 16 & 0 \\ 18 & y \end{vmatrix}$									
B	{	a.	$\begin{vmatrix} 16 & 0 \\ 16 & 0 \\ x & 0 \end{vmatrix}$	b.	$\begin{vmatrix} 18 & 0 \\ 18 & 1 \\ x & 0 \end{vmatrix}$	c.	$\begin{vmatrix} 18 & 1 \\ 18 & 1 \\ x & 0 \end{vmatrix}$	d.	$\begin{vmatrix} 18 & 1 \\ 18 & 2 \\ x & 0 \end{vmatrix}$	e.	$\begin{vmatrix} 18 & 0 \\ 18 & 1 \\ 18 & y \end{vmatrix}$		
		f.	$\begin{vmatrix} 18 & 1 \\ 18 & 1 \\ 18 & y \end{vmatrix}$	g.	$\begin{vmatrix} 18 & 2 \\ 18 & 2 \\ 18 & y \end{vmatrix}$	h.	$\begin{vmatrix} 16 & 0 \\ 18 & 1 \\ 18 & y \end{vmatrix}$	i.	$\begin{vmatrix} 16 & 0 \\ 18 & 2 \\ 18 & y \end{vmatrix}$	j.	$\begin{vmatrix} 16 & 0 \\ 16 & 0 \\ 18 & y \end{vmatrix}$		
	C	{	a.	$\begin{vmatrix} 18 & 1 \\ 16 & 0 \\ x & 0 \end{vmatrix}$	b.	$\begin{vmatrix} 18 & 1 \\ 18 & 1 \\ x & 0 \end{vmatrix}$	c.	$\begin{vmatrix} 18 & 1 \\ 18 & 2 \\ x & 0 \end{vmatrix}$	d.	$\begin{vmatrix} 18 & 2 \\ 18 & 2 \\ 18 & y \end{vmatrix}$	e.	$\begin{vmatrix} 18 & 1 \\ 18 & 1 \\ 18 & y \end{vmatrix}$	f.
g.			$\begin{vmatrix} 16 & 0 \\ 16 & 0 \\ 18 & y \end{vmatrix}$										

straight lines (See Fig. II-2). Though there is no doubt that the chemical potential of a triglyceride molecule is principally affected by the number of $-\text{CH}_2-$ units or $-\text{CH}=\text{CH}-$ units, more precise concepts can be introduced. Namely:

I. One hydrocarbon chain of the triglyceride molecule, $-\text{CH}_2-$ and $-\text{CH}=\text{CH}-$

Table II-3. Relative retention time calculated from the HPLC chromatograms of E.G. Perkins et al. in *J. Am. Oil Chem. Soc.*, **58**, 867~872 (1981) and in *Lipids*, **17**, 460~463 (1982)

Molecular species	RRT*	Molecular species	RRT*
La La La	21.9	M O P	101.1
tri-13:0	33.9	S O L	104.1
L L Le	34.3	S P L	108.7
M M M	42.1	P O O	113.1
L L L	44.8	S O M	117.3
L O L	58.7	P O P	120.1
L L P	63.3	P P P	132.9
L O O	76.7	S O O	144.2
tri-15:0	81.8	S S L	145.0
P L O	83.7	S O P	152.7
P P L	89.5	(S O O)	155.3
P L P	90.7	S P O	162.3
L P P	94.2	S P P	179.8
O O O	100.0	S O S	208.1

Abbreviations:

La: Lauryl, L: Linoleyl, Le: Linolenyl,

M: Myristyl, O: Oleyl, P: Palmityl.

*RRT: Relative retention time when OOO is used as the reference peak.

can be considered as a physicochemical functional group. In addition, the differences in arrangement of these units might affect the total chemical potential of triglyceride molecule and this should be considered (We will call this the \mathcal{Q} factor).

II. Unless the three carbon chains are the same, we should consider differences between the positional isomers (i.e. binding position of the acyl group).

III. Specific fatty acids such as iso-, trans- or hydroxy fatty acids should also affect the total chemical potential of triglyceride molecule.

For the purpose of this discussion, we will not consider III, since retention data on these triglycerides are not forthcoming. The chemical potential (μ) of triglyceride

$\begin{vmatrix} c_1 & d_1 \\ c_2 & d_2 \\ c_3 & d_3 \end{vmatrix}$ can then be written as follows:

$$\mu = g\{f(c_1, d_1, \mathcal{Q}_1), f(c_2, d_2, \mathcal{Q}_2), f(c_3, d_3, \mathcal{Q}_3)\} \quad (2)$$

where \mathcal{Q} is the \mathcal{Q} factor, f is the chemical potential given by the hydrocarbon chain, and g is the function of chemical potential given by the differences in positional isomers.

Function (2) sums up the chemical potential of the triglyceride molecule, and, therefore represents factors that control the sequence of elution on HPLC.

In order to derive an ECN from function (2), we shall neglect factor II, and suppose that there is no contribution from positional isomers. We can rewrite function (2) as:

$$\mu = f(c_1, c_2, \Omega_1) + f(c_2, d_2, \Omega_2) + f(c_3, d_3, \Omega_3) \quad (3)$$

In addition to this, if we neglect the Ω factor, function (3) will become:

$$\mu = f(c_1, d_1) + f(c_2, d_2) + f(c_3, d_3) \quad (4)$$

A commutative law should hold at function (4) since positional isomers (binding position of the acyl group) are not considered. Therefore:

$$\mu = f(c_1 + c_2 + c_3, d_1 + d_2 + d_3) \quad (5)$$

$$= f(CN, DB) \quad (6)$$

This function (6) corresponds to the function for ECN.

There is an empirically a derived linear relationship between the logarithm of the RRT of a molecular species of a triglyceride versus *CN* or *DB* when only one acyl group differs in carbon number or number of double bonds. For ease of comprehension, a matrix model has been used to exhibit this relationship. Mathematically, this can be written as follows:

$$\log(RRT) = P_1 \cdot C_1 + q_1 \quad (1)$$

$$\log(RRT) = P_2 \cdot C_2 + q_2 \quad (2)$$

$$\log(RRT) = P_3 \cdot C_3 + q_3 \quad (3)$$

$$\log(RRT) = P'_1 \cdot D_1 + q'_1 \quad (4)$$

$$\log(RRT) = P'_2 \cdot D_2 + q'_2 \quad (5)$$

$$\log(RRT) = P'_3 \cdot D_3 + q'_3 \quad (6)$$

where RRT is the relative retention time, C_1, C_2, C_3 are the acyl carbon numbers (variable) in each acyl group. D_1, D_2, D_3 are the numbers of double bonds (variable) in each acyl group. $P_1, P_2, P_3, P'_1, P'_2, P'_3$ are the slopes (constant) and $q_1, q_2, q_3, q'_1, q'_2, q'_3$ are the intercept (constant) from the semilogarithmic plots of $\log(RRT)$ of each molecular species of triglyceride against *CN* and *DB*.

By adding both sides of equations (1) through (6):

$$6 \cdot \log(RRT) = P_1 \cdot C_1 + P_2 \cdot C_2 + P_3 \cdot C_3 + P'_1 \cdot D_1 + P'_2 \cdot D_2 + P'_3 \cdot D_3 + q_1 + q_2 + q_3 + q'_1 + q'_2 + q'_3 \quad (7)$$

If we substitute $P_n = 1/6 P_n, P'_n = 1/6 P'_n, \Sigma q/6 = Q$, the following function can be obtained:

$$\log(RRT) = P_1 \cdot C_1 + P_2 \cdot C_2 + P_3 \cdot C_3 + P'_1 \cdot D_1 + P'_2 \cdot D_2 + P'_3 \cdot D_3 + Q \quad (8)$$

This formula (8) can be considered as the first order combination of $C_1, C_2, C_3, D_1, D_2, D_3$ against $\log(RRT)$.

$C_1, C_2, C_3, D_1, D_2, D_3$ are independent variables (in another words predictor variables) and $\log(RRT)$ corresponds to the dependant variable (in another words, the criterion variable).

Thus we have reached an equation that predicts the RRT of individual molecular species of triglyceride.

By calculating the regression expression, we can predict the RRTs from several kinds of predictor variables that are $C_1, C_2, C_3, D_1, D_2, D_3$. Or at the same time, it is possible to see all-inclusive correlations between the criterion variable i.e. RRT and the predictor variables.

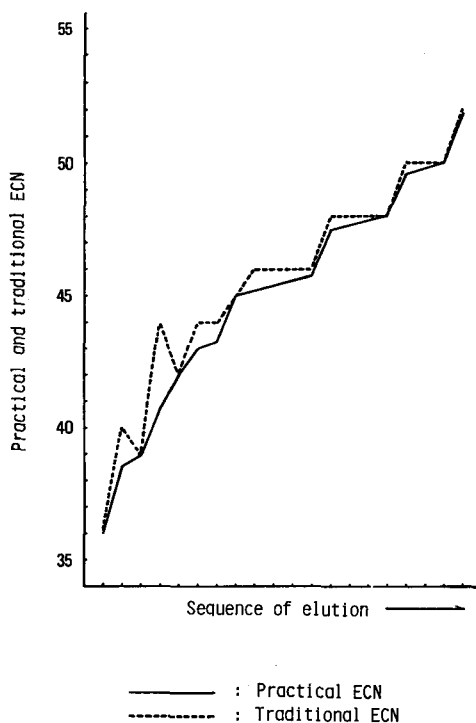

Fig. II-3. Practical ECN suggested in this study and the traditional ECN in relation to the sequence of elution of triglyceride molecular species on HPLC.

Standard chromatograms of Perkins *et al.*^{11,38)} were introduced in order to calculate the RRTs of each molecular species of triglyceride (Table II-3). Results from calculation of the regression expression were:

$$\log(RRT) = 5.57391 \cdot C_1 + 5.90109 \cdot C_2 + 7.00699 \cdot C_3 - 11.63260 \cdot D_1 - 13.40241 \cdot D_2 - 15.40738 \cdot D_3 - 85.77448 \quad (9)$$

The multiple correlation coefficient was 0.99418.

Unfortunately, in the standard chromatograms mentioned above, we were unable to distinguish triglyceride isomers (the binding position of the acyl groups). So, the coefficients of C_1 , C_2 , C_3 should be equivalent. And the coefficients of D_1 , D_2 , D_3 should also be equivalent. Therefore, formula (8) can be rewritten as:

$$\begin{aligned} \log(RRT) &= P \cdot (C_1 + C_2 + C_3) + P' \cdot (D_1 + D_2 + D_3) + Q \\ &= P \cdot (CN) + P' \cdot (DB) + Q \end{aligned} \quad (10)$$

Function (10) is actually the same as the definition of ECN since P'/P corresponds to the coefficient -2 in *ECN*. The actual calculation of P'/P from formula (9) gave -2.2 , nearly but not equal to the *ECN* definition ratio of -2 . If we use -2.2 for P'/P , it is possible to distinguish the following pairs that have the same *ECN* (=38):

$$\left| \begin{array}{c|c} 18 & 1 \\ 20 & 4 \\ 22 & 6 \end{array} \right| \quad (\text{A}) \quad \left| \begin{array}{c|c} 16 & 0 \\ 20 & 4 \\ 22 & 6 \end{array} \right|$$

By using a coefficient -2.2 , the ECN' of (A) becomes $60 - 2.2 \times 11 = 35.8$ and the ECN' of (B) becomes $58 - 2.2 \times 10 = 36.0$. The authors have performed a sequence simulation on the HPLC data of Table II-3 using formula (10). The results are shown in Fig. II-3. It is clear from Fig. II-3 that all the molecular species in Table II-3 become resolvable (shown as a solid line). In conclusion, we might say the coefficient of the ECN should not be an integer, and this coefficient is affected by the analytical conditions employed. This was also supported by the latest work done by Toya *et al.*⁴³⁾

Formula (10) that corresponds to the definition of ECN has two independent variables and one dependent variable whereas formula (8) has six independent variables. This implies that with only two independent variable, it is impossible to accurately predict the RRT of an individual molecular species, and that six independent variables are inevitably needed for the prediction of RRT 's of triglyceride molecular species.

However, we can conclude that formula (8) can be employed for contemporary HPLC analysis.

CHAPTER III Lecithin Molecular Species Identification Program for the Personal Computer

So far, the matrix model, namely, the formulae that control the sequence in elution of individual molecular species on HPLC have described.

The next step of this study was the efficient progress in the molecular species identification on HPLC chromatograms by utilizing these formulae. A personal computer was introduced for this purpose. NEC personal computer Model PC-8001 (NEC Ltd. Tokyo) was used.

Section 1. Lecithin Molecular Species Identification Program Version I

At first, the slopes of the formulae (formulae (8') and (9') in chapter I) were set by analyzing the data of lecithin molecular species on HPLC that had been accumulated. And the intercepts of the same formulae were all determined by the regression analysis. The identification program was designed by using these slopes and intercepts (intersections). Though this identification program was a concrete form of the chromatographic rules presented in chapter I (formulae (8') and (9')), there were some identification errors. It was observed that in some cases, specifically in the case of tetraene group, there were some deviations as shown in Fig. III-1 resulting in the errors for the molecular species identification. The main reasons were considered to be the following two:

1. When the peaks overlap, it is hard to determine the RRT 's of positional isomers.
2. Both $\omega 3$ and $\omega 6$ type fatty acids exist in tetraene groups that make the

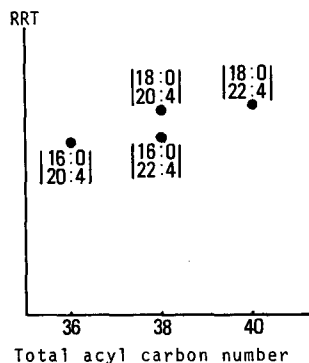

Fig. III-1. Deviations in tetraene and saturate combination group.

large deviation of RRT.

So, it can be concluded that the thorough development of instruments i.e. the column, the pump etc. of HPLC are required in order to clarify the RRT differences in positional isomers as well as the differences in ω isomers, and to complete the molecular species identification program that exactly reflexes the formulae ((8') and (9')).

Section 2. Lecithin Molecular Species Identification Program Version II

Though it was found to be hard to design a computer program that strictly follows the chromatographic rules presented in this study due to the inadequate information of RRT between the isomers or the inadequate reproducibility of RRT on the present HPLC, a more practical identification program based on the collation with the deposit data were designed. It runs as follows as designated in Scheme III-1:

At first, the fatty acid composition data of the collected peak on HPLC is entered (shown as B in Scheme III-1) after initialization (shown as A). Then the identification subroutine starts running according to the priority order of identification that goes as follows:

1. Search the same molecular species in the data file and when there is, then print out the RRT of it that meets the condition of α which restricts the range of RRT that has entered from the keyboard manually (shown as C-1 and D, E). This is called "PREDICTED BY S.T.D. RRT" in Program III-1.

2. If not in the case of 1, search the molecular species that belongs to $\begin{vmatrix} x & d_1 \\ c_2 & d_2 \end{vmatrix}$ (or $\begin{vmatrix} c_1 & d_1 \\ x & d_2 \end{vmatrix}$) group, and then generate a regression line as shown in Fig. III-2. After that, print out the RRT of it that meets the condition of α (shown as C-2 and D, E). This is called "Liner prediction routine" as well as "RREDICTED BY 3-VAR. LINER METHOD" in Program III-1.

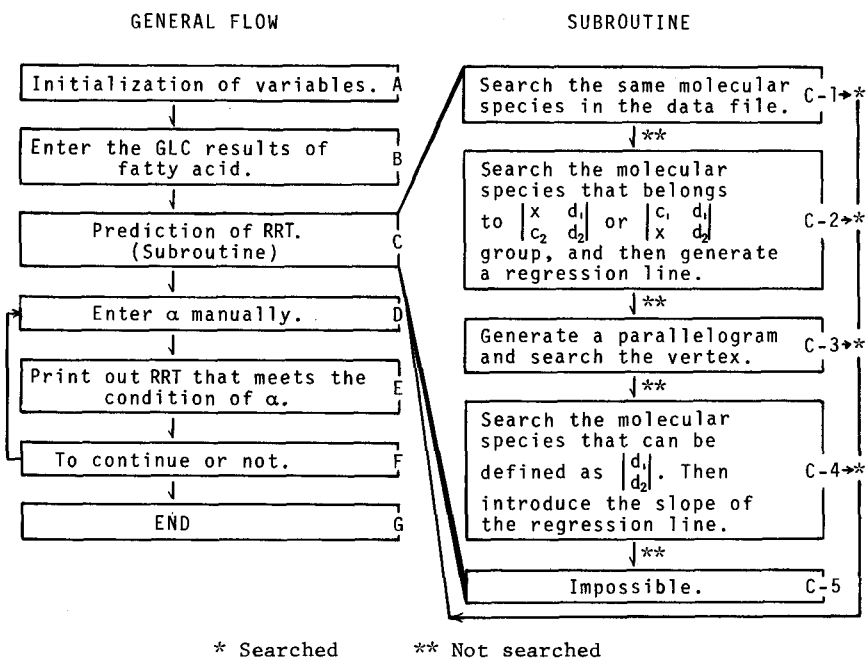

Scheme III-1. Flow chart of the lecithin molecular species identification program for the personal computer.

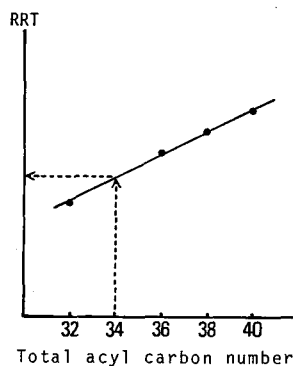

Fig. III-2. Relative retention time prediction by the regression line.

3. If not the cases of 1 and 2, search the molecular species that can be defined as $\begin{vmatrix} d_1 \\ d_2 \end{vmatrix}$ and then search the molecular species that can generate a parallelogram (network) as shown in Fig. III-3, and print out the RRT of the vertex molecular species on the parallelogram that meets the condition of α (shown as C-3 and D, E). This is called "NETWORK PREDICTION" in Program III-1.

```

1 PRINT "IF YOU WANT TO ONLY PREDICT ONE M.S. RRT THEN ELASE / OF LINE 75" ;DELET
E 1:END
40 ' D.G. RRT PREDICT PROGRAM LAST VERSION ( EVERY WAY )
60 WIDTH80,25;CONSOLE,,0,1;COLOR7,0,1;PRINT CHR$(12);LOCATE 10,10 ;PRINT "MOLECU
LER SPECIES OF DI-GLYCERIDE DETERMINATION HELPER";LOCATE 10,12;PRINT "PROGRAMED
BY MAKOTO EGI 1983.10.18.";LINE(16,36)-(130,54),PSET,B
70 LOCATE 15,18;PRINT "INITIALIZE PHASE": GOSUB 7000
72 PRINT CHR$(12)
75 'INPUT C1,D1,C2,D2;GOSUB 1000;PRINT PR,ME$(M);GOTO 75
80 FOR I=1 TO 10 :FC(I)=0;FD(I)=0;FP(I)=0;FOR J=1 TO 10;MM(I,J)=0;ML(I,J)=0;NEXT
J;NEXT I;PRINT CHR$(12)
90 PRINT ;INPUT "SAMPLE NAME IS ";SN$;INPUT "HPLC PEAK NO. IS ";NS;PRINT ;INPUT
INCLUDING F.A. NO.";IN
100 PRINT ;FOR I=1 TO N
110 PRINT "F.A. NO. ";I;INPUT"CARBDN NO. ";FC(I);INPUT"DOUBLE BOND NO. ";FD(I);PRI
NT ;NEXT I;PRINT CHR$(12)
120 PRINT "SAMPLE NAME : ";SN$;PRINT ;PRINT ;PRINT "HPLC PEAK NO. ";NS;PRINT
;PRINT "CALCULATING NO. ";S;S=S+1;PRINT ;PRINT "INCLUDING F.A. OF THIS PEAK " ;PR
INT
130 FOR I=1 TO N;PRINT "F.A. NO. ";I;PRINT " ";FC(I);";";FD(I);" ";
NEXT I;PRINT ;PRINT "OK";PRINT
140 INPUT "REAL RRT OF THIS PEAK";RT;PRINT ;PRINT "NOW CALCULATING PHASE";PRINT
150 FOR I1=1 TO N;FOR J1=1 TO I1;C1=FC(I1);C2=FC(J1);D1=FD(I1);D2=FD(J1);GOSUB 1
000;MM(I1,J1)=PR;ML(I1,J1)=M;NEXT J1;NEXT I1
160 BEEP;PRINT "CALCULATION ENDED";PRINT
170 INPUT "ENTER MAX. OF ALPHA";K;PRINT
180 FOR I=1 TO N;FOR J=1 TO I;IF ABS(MM(I,J)-RT)<K THEN PRINT " |";FC(I);";";FD(I
);"; |";PRINT " |";FC(J);";";FD(J);";"; P.RRT=";MM(I,J);" ALPHA=";MM(I,J)-RT;P
RINT ;PRINT " METHOD :";ME$(ML(I,J));PRINT
190 NEXT J;NEXT I
200 AN$="yes";INPUT "ANY MORE PREDICTION ";AN$;IF AN$="yes" THEN 170
210 AN$="yes";INPUT "ANY MORE CALCULATION ";AN$;IF AN$="yes" THEN 80
900 GOTO 80
1000 '----- PR Calculation -----
1010 K=0;K1=0;K2=0;PR=0;M=1
1015 IF D1>D2 THEN C=C1;D=D1;C1=C2;D1=D2;C2=C;D2=D
1020 IF (D1=D2 AND C1>C2) THEN C=C1;D=D1;C1=C2;D1=D2;C2=C;D2=D
1030 FOR I=1 TO SN;IF D1=SD(I,2) AND D2=SD(I,4) THEN K=K+1;SS(K)=I;NEXT I ELSE NE
XT I
1070 FOR I=1 TO K;IF C1=SD(SS(I),1) AND C2=SD(SS(I),3) THEN PR=SD(SS(I),5);M=2;G
OTO 1200 ELSE NEXT I
1080 FOR I=1 TO K;IF C1=SD(SS(I),1) THEN K1=K1+1;S1(K1)=SS(I)
1085 IF C2=SD(SS(I),3) THEN K2=K2+1;S2(K2)=SS(I)
1090 NEXT I
1110 IF K1>=2 OR K2>=2 THEN GOSUB 4000;GOTO 1200
1130 IF FO(D1,D2,1)=1 THEN T1=LOG(SD(FO(D1,D2,4),5))*43.429;T2=(C1-SD(FO(D1,D2,4
),1))*FO(D1,D2,2);T3=(C2-SD(FO(D1,D2,4),3))*FO(D1,D2,3);PR=10^((T1+T2+T3)/100);M
=5;GOTO 1200
1145 IF K>0 THEN PR=10^((A1*(C1+C2)+00(D1,D2))/100);M=3;GOTO 1200
1150 M=1;PR=0
1200 RETURN
4000 '----- Liner prediction routine -----
4005 SX=0;SY=0;XX=0;YY=0;XY=0;M=4
4010 IF K1>=2 THEN FOR I=1 TO K1 :X=SD(S1(I),1)+SD(S1(I),3);Y=LOG(SD(S1(I),5))*4
3.43;SX=SX+X;SY=SY+Y;XX=XX+X*X;YY=YY+Y*Y;XY=XY+X*Y;NEXT I;KS=XX-SX*SX/K1;LS=XY-S
X*SY/K1;MS=YY-SY*SY/K1;A4=LS/KS;B4=SY/K1-A4*SX/K1;R4=LS/SQR(LS*MS)
4015 SX=0;SY=0;XX=0;YY=0;XY=0;P1=(C1+C2)*A4+B4;P1=10^(P1/100)
4020 IF K2>=2 THEN FOR I=1 TO K2 :X=SD(S2(I),1)+SD(S2(I),3);Y=LOG(SD(S2(I),5))*4
3.43;SX=SX+X;SY=SY+Y;XX=XX+X*X;YY=YY+Y*Y;XY=XY+X*Y;NEXT I;KS=XX-SX*SX/K2;LS=XY-S
X*SY/K2;MS=YY-SY*SY/K2;A5=LS/KS;B5=SY/K2-A5*SX/K2;R5=LS/SQR(LS*MS)
4025 P2=(C1+C2)*A5+B5;P2=10^(P2/100)
4030 IF K1>K2 THEN PR=P1 ELSE IF K1<K2 THEN PR=P2
4990 RETURN
7000 '----- PR Calculation Initialize -----
7005 SN=69;K=0;K1=0;K2=0;PR=0;T=24;A1=7.66589;PR=0
7010 DIM SD(SN,5),SS(15),FO(6,6,4),DS(T,2),Q3(T),QQ(7,7),FC(10),FD(10),FP(10),MM
(10,10),ML(10,10)
7020 FOR I=1 TO SN;FOR J=1 TO 5;READ SD(I,J);NEXT J;NEXT I
7030 FOR I=1 TO T;FOR J=1 TO 2;READ DS(I,J);NEXT J;READ Q3(I);QQ(DS(I,1),DS(I,2)
)=Q3(I);NEXT I
7040 FOR I=1 TO 5;READ ME$(I);NEXT I
7050 FOR I=1 TO 5;READ DO,DT;FO(DO,DT,1)=1;FOR II=2 TO 4;READ FO(DO,DT,II);NEXT
II;NEXT I
7060 FOR I=1 TO 2;FOR J=1 TO 2;READ P$(I,J);NEXT J;NEXT I
9040 RETURN
10000 '----- DATA SET OF STD. D.G. RRT ( MEAN OF DATA ) FROM D.G. BOOK ----
10010 DATA 16,0,16,0,213
10020 DATA 14,0,18,1,141.8,18,0,18,1,295.2,16,0,18,1,208.786,15,0,18,1,175.7,16,
0,17,1,175.7,16,0,16,1,148.45,14,0,20,1,212,16,0,20,1,301.9

```

```

10030 DATA 14,0,18,2,100,16,0,16,2,111.7,16,0,18,2,145.7,17,0,18,2,167.9,18,0,18
,2,202.9,20,0,18,2,288.6
10040 DATA 16,1,18,1,138.26,18,1,18,1,191.175
10050 DATA 16,1,18,2,100,18,1,18,2,135.45,20,1,18,2,188.1
10060 DATA 16,0,18,3,110.6,18,0,18,3,152.9
10070 DATA 16,0,20,4,122.057,16,0,22,4,132.9,18,0,20,4,177.55,18,0,22,4,191.7
10080 DATA 18,1,18,3,99.9
10090 DATA 18,2,18,2,97.9
10100 DATA 14,0,20,5,63.85,15,0,20,5,77.8,16,0,20,5,91.5667,14,0,22,5,82.3,16,0,
22,5,122.288,18,0,20,5,137.133
10110 DATA 16,1,20,4,76.9,18,1,20,4,114.95
10120 DATA 18,2,18,3,70.4
10130 DATA 14,0,22,6,68.9143,15,0,22,6,82.8333,16,0,22,6,98.77,17,0,22,6,121.65,
18,0,22,6,147.65
10140 DATA 16,1,20,5,60.84,18,1,20,5,86.8125,18,1,22,5,114.2,20,1,20,5,125.4,24,
1,20,5,265.7,16,1,22,5,78.6
10150 DATA 17,2,20,4,78.4,18,2,20,4,82.7
10160 DATA 16,1,22,6,65.95,17,1,22,6,80.12,18,1,22,6,91.825,20,1,22,6,137.3
10170 DATA 18,2,20,5,60.85,17,2,22,5,78.5,18,2,22,5,79.4
10180 DATA 18,2,22,6,66.8333
10190 DATA 20,4,20,5,52.3,20,4,22,5,74
10200 DATA 18,3,22,6,49.7
10210 DATA 20,5,20,5,37.33,20,5,22,5,51.5,22,5,22,5,78.4
10220 DATA 20,4,22,6,52.725,22,4,22,6,71.1
10230 DATA 20,5,22,6,41.04,22,5,22,6,55.7667
10240 DATA 22,6,22,6,44.68
10500 ----- Q3 DATA -----
10510 DATA 0,0,-11.369,0,1,-28.418,0,2,-45.810,1,1,-47.709,1,2,-63.869,0,3,-56.9
3,0,4,-72.255,0,5,-78.303,1,4,-85.423,2,3,-91.215,0,6,-91.9381,1,5,-97.0845,2,4,
-99.553,1,6,-110.012,2,5,-113.455,2,6,-124.747,4,5,-134.785,3,6,-136.999,5,5,-14
9.348
10520 DATA 4,6,-151.552,5,6,-160.477,6,6,-172.366,1,3,-76.01549,2,2,-77.8345
10600 ----- METHODS -----
10610 DATA "IMPOSSIBLE TO PREDICT.", "PREDICTED BY S.T.D. RRT", "PREDICTED BY (D1,
D2) METHOD.", "PREDICTED BY 3-VAR. LINER METHOD.", "NETWORK PREDICTION"
10700 ----- NETWORK DATA -----
10710 DATA 0,2,7.62355,5.77032,12,0,4,8.13790,1.84811,23,0,5,8.24843,5.51194,29,
1,5,8.01821,5.56167,43,2,5,8.00000,5.77800,58
10720 ----- NAME OF VARIABLE -----
10730 DATA "C1", "D1", "C2", "D2"
10800 STOP
10900 END
    
```

Program III-1. Lecithin molecular species identification program for the personal computer, written in N-BASIC.

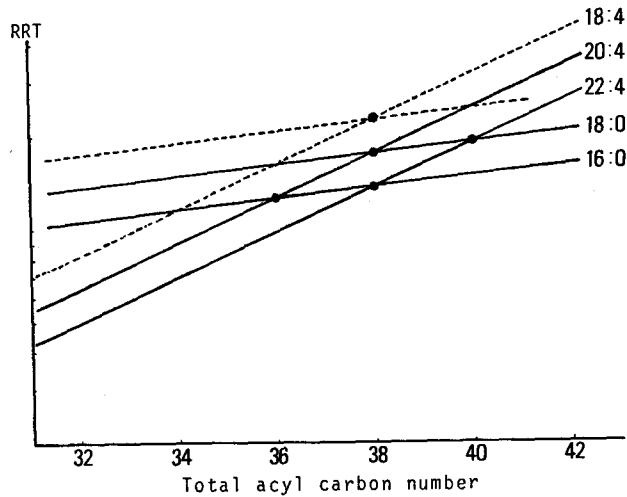

Fig. III-3. Relative retention time prediction by the vertex of a parallelogram.

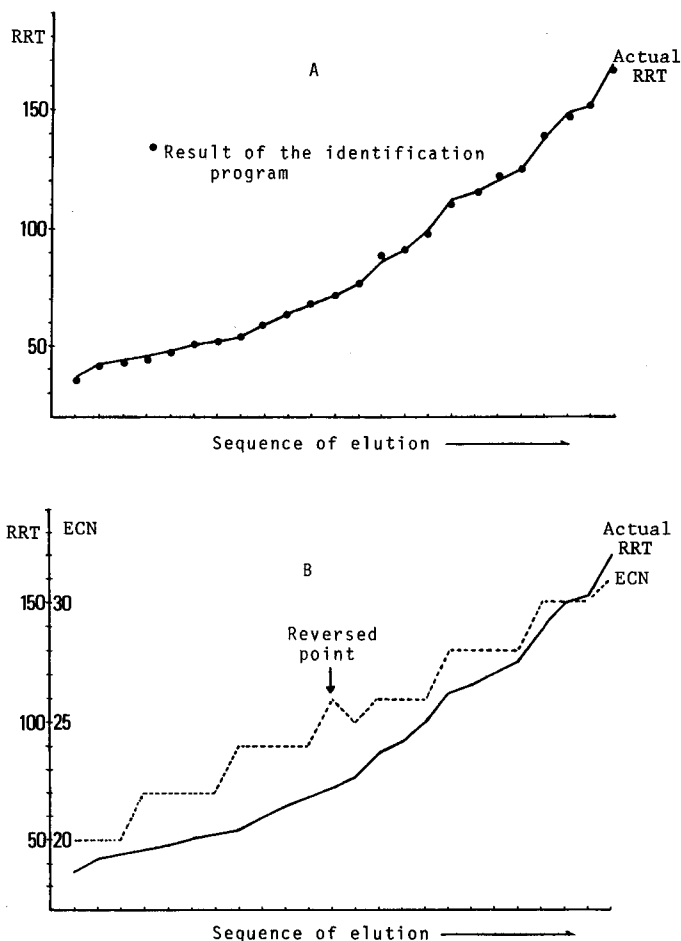

Fig. III-4. Results (RRT prediction) of the lecithin molecular species identification program in relation to the sequence of elution on HPLC. Sample is of sardine muscle.

4. If not the cases of 1,2 and 3, search the molecular species that can be defined as $\left| \begin{matrix} d_1 \\ d_2 \end{matrix} \right|$ as it has been done in 3. Then, introduce the slope and the intercept (shown as Q3 in Program III-1) of the generalized regression line and print out the RRT that meets the condition of α (shown as C-4, D, E). This is called "PREDICTED BY (D1, D2) METHOD" in Program III-1.

5. Impossible (shown as C-5).

Finally, it goes back to the main routine that continues or ends up the identification program. The whole view of the program is shown in Program III-1. The results obtained by this program were compared with the results obtained from the actual analysis of sardine muscle done by enormous labor. Fig. III-4A illustrates the good agreement between the actual analytical results shown by solid line

and the identification via personal computer shown by dots. And for the comparison, ECN (or PN) is also shown (shown by the broken line in Fig. III-4B). None of the reversed point in RRT was observed in this example by the presented identification program making good contrast with those of ECN (or PN).

Although, in some cases, there might be some rare missidentification, this personal computer program is sure to be of great help in predicting the molecular species that are generally found.

CHAPTER IV

Molecular Species of Fish Muscle Lecithin

So far, the formulae that control the sequence of elution of lipid molecular species on HPLC have been demonstrated. It has been proven that the matrix model presented is invariant. And this matrix model forms the bases of molecular species identification of muscle lecithin from fish sources that will be discussed in this chapter.

The characteristics of each fish from the view point molecular species of muscle lecithin is discussed with some supplemental analysis such as principal component analysis.

Section 1. Experimental

Total lipids were obtained from the fish muscle tabulated in Table IV-1 according to the method of Bligh & Dyer. Neutral lipid composition and phospholipid composition were measured by the Iatroscan-Chromarod Method⁴⁴⁻⁴⁷. The developing solvent used were n-hexane/diethyl ether/formic acid (85 : 15 : 0.5, v/v) for the former and chloroform/methanol/ammonia/water (70 : 30 : 2 : 3, v/v) for the latter. Phospholipid content was determined by multiplying 25 to the phosphorus content of the lipid which had been determined by Fiske-Sabbarow method. Preparation of pure lecithin, hydrolysis of lecithin into diglyceride, and derivation to diglyceride acetate from diglyceride were done in the same manner as shown in chapter I. HPLC fractionation and identification of molecular species of each peak on HPLC were also done in the same manner though a new matrix model is available in identifying the molecular species in order to verify the results.

Results and Discussion

Section 2. Characteristics of Muscle Lecithin of Fish

The yield of total lipid and the percentage of each lipid class against total lipid are shown in Table IV-2 and Table IV-3. Fatty acid composition of diglyceride acetates which represent the fatty acid composition of lecithin are shown in Table IV-4 and Table IV-5. Samples shown in these tables were subjected to the lecithin molecular species analysis.

HPLC chromatograms of each fish are shown in Figs. IV-1~6 and the detected molecular species of lecithin in sequence of elution on HPLC with the percentage data and those of mg/100 g muscle are shown in Figs. IV-7~32.

As illustrated in Fig. IV-1, the HPLC chromatogram of diglyceride acetate of

Table IV-1. Fish examined

Samples	Mean body length and weight Locality of catch	Date of catch	
Sardine <i>Sardinops melanosticta</i>	20.0 cm, 80 g Kamiiso, Hokkaido	July 1982	A
	17.1 cm, 43 g Kamiiso, Hokkaido	Oct. 1983	
Mackerel <i>Scomber japonicus</i>	41.8 cm, 647 g Kamiiso, Hokkaido	July 1982	
	32.2 cm, 409 g Todohokke, Hokkaido	Oct. 1983	
Big-eyed tuna, Frozen <i>Parathunnus obeus</i>	110.0 cm, 20 kg from the market	—	
	100.0 cm, 24 kg Indian sea	—	
Brown sole <i>Limanda ferruginea</i>	23.7 cm, 169 g Kikonai, Hokkaido	Oct. 1982	B
	21.2 cm, 207 g Kamiiso, Hokkaido	May 1983	
Sand flounder <i>Linanda punctatissima</i>	18.3 cm, 65 g Kamiiso, Hokkaido	Dec. 1982	
	18.6 cm, 139 g Abuta, Hokkaido	May 1983	
Rock fish <i>Sebastes schlegeli</i>	19.6 cm, 187 g Toi, Hokkaido	Oct. 1982	C
	27.0 cm, 471 g Kamiiso, Hokkaido	July 1983	
Alaska pollack <i>Theraga chalcogramma</i>	44.0 cm, 610 g Uchiura bay, Hokkaido	Dec. 1981	
	41.7 cm, 509 g Shikabe, Hokkaido	Jan. 1984	
Chum salmon, Male <i>Oncorhynchus keta</i>	65.0 cm, 3500 g Akkeshi, Hokkaido	June 1980	
	42.7 cm, 1367 g 45°59'–49°29'N, 167°07'–175°30'E	Aug. 1983	
Chum salmon, Female <i>Oncorhynchus keta</i>	46.8 cm, 1593 g 45°59'–49°29'N, 167°07'–175°30'E	"	
Blue shark <i>Prionace grauca</i>	114.5 cm, 8.5 kg 38°30'–39°30'N, 155°00'E	June 1982	D
Mackerel shark <i>Lamna cornubica</i>	88.5 cm, 10.2 kg 41°30'–43°00'N, 175°30'E	July 1982	
Carp <i>Cyprinus carpio</i>	23.0 cm, 175 g from the market	Sep. 1980	E
Rainbow trout <i>Salmo gairdnerii irideus</i>	33.8 cm, 455 g Nanae, Hokkaido 38.0 cm, 780 g Nanae, Hokkaido	Sep. 1982 May 1983	

A: Migratory fish B: Bottom fish C: Hard to classify

D: Cartilaginous fish E: Fresh water fish

Table IV-2. Lipid composition of muscle of fish captured in 1980~1982

Sample	Lipid	Yield*	Non-phospholipid**				Phospholipid**		
			TG	FFA	ST	NP others	PC	PS+PE	PL others
Sardine (DM)		26.8	92.5	0.4	0.4	1.7	3.7	1.8	trace
Sardine (WM)		4.3	83.1	0.5	1.8	2.0	8.6	2.6	0.2
Mackerel (DM)		5.8	72.5	0.9	0.3	0.3	4.6	8.5	2.6
Mackerel (WM)		0.9	32.0	2.7	2.5	1.2	33.2	9.4	5.6
Big-eyed tuna		0.7	13.4	0.2	1.7	trace	59.4	9.0	0.5
Brown sole		1.7	62.2	5.4	2.3	0.7	16.0	3.1	3.4
Sand flounder		1.3	64.1	0.9	2.0	4.2	18.8	1.1	0.6
Rock fish		1.4	58.8	2.5	0.5	0.3	18.5	3.8	5.0
Alaska pollack		1.0	7.3	1.9	7.8	trace	81.2	trace	1.7
Blue shark		0.6	1.1	0.2	6.0	1.3	56.5	20.1	6.2
Mackerel shark		2.0	48.9	2.2	1.9	1.5	23.1	8.5	13.9
Carp		1.6	55.5	trace	6.7	trace	29.1	12.4	2.7
Rainbow trout		3.3	72.7	1.1	0.5	0.1	11.7	5.0	0.4

See the abbreviations in the opening.

* g/100 g muscle. ** g/100 g total lipid.

Table IV-3. Lipid composition of muscle of fish captured in 1983~1984

Sample	Lipid	Yield*	Non-phospholipid**				Phospholipid**		
			TG	FFA	ST	NP others	PC	PS+PE	PL others
Sardine (DM)		3.3	53.8	1.9	2.1	1.2	11.2	27.7	2.1
Sardine (WM)		0.8	29.2	0.3	4.8	6.3	12.1	44.3	5.0
Mackerel (DM)		20.0	90.9	0.2	0.4	1.3	2.4	4.5	0.3
Mackerel (WM)		8.5	92.0	trace	0.6	0.9	4.6	0.6	1.3
Big-eyed tuna		0.5	6.4	3.8	13.4	2.8	11.7	57.8	4.1
Brown sole		0.9	20.0	trace	6.0	2.1	17.5	54.0	0.4
Sand flounder		1.7	62.9	2.5	3.0	3.4	7.9	18.6	1.7
Rock fish		1.6	79.0	trace	1.0	0.2	3.5	13.4	2.9
Alaska pollack		0.7	3.6	3.0	9.8	2.6	26.7	47.0	7.3
Rainbow trout		2.5	69.8	1.0	1.1	0.2	8.9	17.6	1.4

For chum salmon, see Table IV-9.

See the abbreviations in the opening.

* g/100 g muscle. ** g/100 g total lipid.

fish muscle lecithin can be divided into four molecular species groups, that is, I: molecular species composed of highly unsaturated fatty acids such as 20:5 or 22:6, for instance (20:5)(20:5), (20:5)(22:6) and (22:6)(22:6), III: molecular species composed of generally found fatty acids such as 16:0 or 18:1 with combinations of 20:5 or 22:6, that is (20:5)(18:1), (18:1)(20:5), (22:6)(18:1), (18:1)(22:6), (20:5)(16:0), (16:0)(20:5), (22:6)(16:0) and (16:0)(22:6), and II and IV: others. As it is evident from the chromatograms (see Figs. IV-1~6), groups I and III accounts for at least 60% of the molecular species examined. Specifically, as shown in Fig. IV-1 and Fig. IV-8, groups I and III of the sardine white muscle accounts for about 87~88%. These two groups might control or represents the characteristics of lecithin of fish muscle.

The left side chromatograms in Fig. IV-1 are the sardines captured in summer (July, 1982) and the right side chromatograms are of those captured in fall (Oct. 1983). Though a supplementary experiment should be done to be conclusive, molecular species composition of group III seems to change drastically in accordance with the seasonal change.

Figure IV-2 shows the chromatograms of mackerels captured in the same day with sardine. The characteristics of this fish is the very complicated composition in

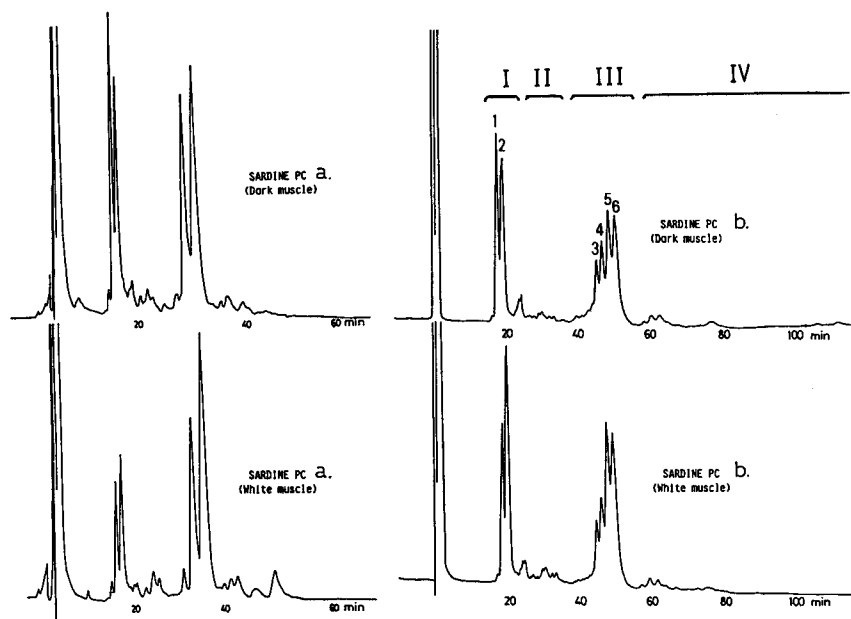

I: Groups composed of highly unsaturated fatty acids, that is, 1:(20:5)(22:6), 2:(22:6)(22:6)

III: Groups composed of highly unsaturated fatty acids and generally found fatty acids, that is, 3:(20:5)(16:0), 4:(16:0)(20:5), 5:(22:6)(16:0) and 6:(16:0)(22:6)

II&IV: Others

Fig. IV-1. HPLC chromatograms of sardine muscle lecithin.

a: Captured in 1982 b: Captured in 1983

Table IV-4. Fatty acid composition of diglyceride acetate

Sample Fatty acid	Sardine		Mackerel		Big-eyed tuna	Brown sole	Sand flounder
	DM	WM	DM	WM			
12:0							
14:0	1.09	1.48	0.98	1.39	0.72	2.00	1.54
15:0		0.37	0.26	0.28	0.63	0.68	0.90
16:0	18.42	32.35	30.82	24.42	25.60	22.70	29.14
16:1	0.74	1.78	2.13	0.75	0.48	1.95	1.83
17:0	0.82	0.52	0.56	0.52	1.46	1.22	1.09
17:1	0.48	0.50	0.45		0.79	1.11	0.90
18:0	5.99	1.11	0.90	4.29	0.92	1.93	1.41
18:1	18.69	6.80	4.22	12.09	7.24	10.24	8.27
18:2	1.09	1.84	0.45	1.34	0.56	0.21	
19:1	0.45	0.63	0.21	0.32		0.33	
19:2		1.44	0.34			1.31	
20:0			1.26				0.97**
20:1	1.93	0.94		1.15		1.29**	
20:2							
20:3		0.30					
20:4	3.50	2.71	1.96	3.37	5.27	7.43	6.97
20:5	10.47	13.98	18.64	11.08	4.58	31.60	27.59
22:1							
22:2						0.24	
22:3		0.62	0.37			0.66	
22:4	1.37	0.45	0.42	1.14	5.75	0.38	0.89
22:5	3.39	1.76	1.11	2.16	0.44	4.51	2.73
22:6	31.57	30.42	34.90	35.70	45.56	10.69	15.77
24:2							
24:3							
24:6						0.30	
Unknown						0.21	

* Feeding migration, Male. ** Ether 20:0 or 20:1.

DM: Dark muscle. WM: White muscle.

group IV especially in dark muscle. Molecular species of (16:0) (22:5), (16:0) (20:4), (17:1) (22:6), (20:5) (18:0), (18:0) (20:5), (22:6) (18:0) and (18:0) (22:6) can be named in this group (see also Fig. IV-9).

Figure IV-3 shows the chromatograms of bottom fish captured in October, December and May. These fish are extremely outstanding since the most predominant component of these fish is (16:0) (20:5) instead of (16:0) (22:6) unlike other fish examined (see also Fig. IV-12 and Fig. IV-13).

derived from lecithin of fish muscle, captured in 1980~1982

Rock fish	Alaska pollack	Chum salmon*	Blue shark	Mackerel shark	Carp	Rainbow trout
						0.07
1.11	2.69	3.27	1.04	1.30	1.11	0.97
0.34	0.31	0.69				0.17
26.50	41.88	35.19	22.82	34.80	32.28	29.70
6.51	0.57	0.45	5.40	3.60	2.59	3.30
1.33	0.37	1.04	0.45	trace		0.39
0.91	0.49		0.43	trace		0.32
1.63	0.82	0.78	8.93	2.80	3.08	3.46
16.49	12.32	6.26	10.04	11.30	16.71	29.75
0.66	0.46	0.33	0.77	0.60	9.06	8.60
0.21		0.35	0.35	trace		0.18
	0.29	0.56				
		0.71	1.15**	trace	1.16**	
0.56**	1.65**			2.00		1.31
			1.45	trace		1.13
					0.82	1.32
3.54	0.88	1.07	3.60	4.80	3.85	0.86
13.83	16.79	8.79	10.92	11.30	6.39	1.79
				trace		0.10
						0.05
			0.13	trace		0.07
0.83			1.70	trace		0.31
1.34	0.55	0.89	6.01	2.50	1.17	0.83
24.21	19.93	39.62	24.56	24.90	20.67	14.69
						0.56
						0.06
			0.24		1.11	

The chromatograms of big-eyed tuna, Alaska pollack, carp, rainbow trout are shown in Fig. IV-4, and the chromatograms of rock fish, blue shark, mackerel shark, rainbow trout are shown in Fig. IV-5. Throughout the chromatograms in Fig. IV-4 and Fig. IV-5, (16:0) (22:6) is the most predominant peak though in case of Alaska pollack, it contains (16:0) (22:6) and (16:0) (20:5) almost equally (shown by arrows in Fig. IV-4, see also Fig. IV-15 and Fig. IV-30). The similarity among fresh water fish and cartilaginous fish is the very few content of group I i.e. the molecular

Table IV-5. Fatty acid composition of diglyceride acetate derived from lecithin of fish muscle, captured in 1983~1984

Sample Fatty acid	Sardine		Mackerel		Big-eyed tuna	Brown sole	Sand flounder	Rock fish	Alaska pollack	Rainbow trout
	DM	WM	DM	WM						
14:0	1.08	1.20	0.92	0.83	0.75	2.77	1.77	1.03	2.13	1.27
15:0	0.41	0.43	0.33	0.31	0.49	1.07	0.85	0.32	0.34	0.22
16:0	24.09	36.38	21.15	28.17	33.29	34.11	31.22	33.41	29.01	36.73
16:1	1.43	1.25	1.42	1.34	1.00	7.55	2.39	3.76	1.96	3.01
17:0	0.51	0.50	0.78	0.43	1.75	1.78	1.11	0.74	0.46	0.23
17:1	0.41	0.33	0.57	0.69	0.84	0.84	0.91	0.64	0.36	0.15
18:0	0.88	0.71	5.44	3.05	2.28	2.38	1.70	1.99	0.74	1.81
18:1	5.02	2.11	15.93	10.24	23.02	11.31	10.77	18.93	13.34	12.81
18:2	0.49	0.60	1.89	0.99	0.67	0.46	0.70	1.40	1.23	5.97
19:1 or 18:4	0.17		0.51	0.47	0.31		0.33	0.37	0.45	0.63
19:2	0.17		0.70			0.28		0.23	0.49	0.25
20:0	0.11	0.33	1.30	0.23	0.12	1.05	1.86			0.34
20:1		0.12		0.72	0.98	0.07	2.24	0.75	3.02	0.15
20:2		0.11		0.14	0.33	0.08	0.06	0.21	0.14	0.30
20:3	2.99	0.12	4.26	0.13	0.13	4.64	0.17	0.18	0.06	2.99
20:4	0.15	2.35		3.74	5.96	0.19	4.70	3.87	2.21	0.29
20:5	18.85	14.20	16.41	16.78	3.74	18.53	25.12	10.02	24.46	5.90
22:1						0.11	0.27			
22:3	0.21	0.10	0.25		0.28	1.32	0.70	0.19	0.24	0.22
22:4	0.91	0.71	0.80	0.70	2.51	0.35	0.41	0.47	0.11	0.25
22:5	1.08	0.98	2.46	1.85	0.43	3.71	2.62	1.18	0.56	1.04
22:6	36.06	37.24	24.68	29.11	21.06	7.13	9.89	20.26	18.68	25.35
others	4.98	0.23	0.20	0.08	0.06	0.28	0.21	0.05	0.01	0.09

DM: Dark muscle. WM: White muscle.

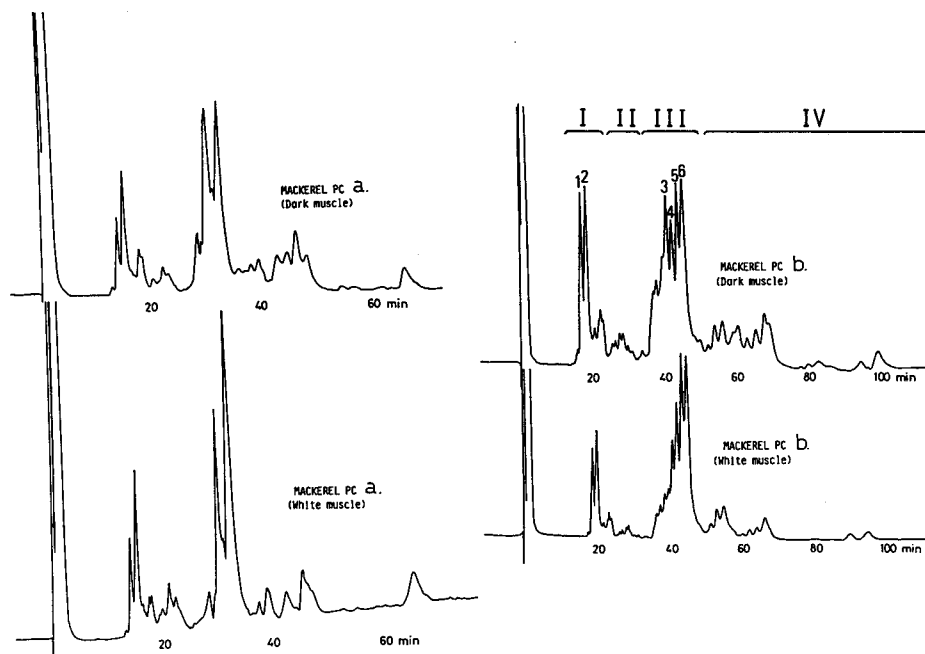

Fig. IV-2. HPLC chromatograms of mackerel muscle lecithin.
 a: Captured in 1982 b: Captured in 1983
 Numbers as in Fig. IV-1.

species composed of highly unsaturated fatty acids such as (20:5) (20:5), (20:5) (22:6) and (22:6) (22:6) (see also Figs. IV-18~21), although the former contains less amount of molecular species that contains 20:5. The content of group I differs significantly in the case of big-eyed tuna. This is seemed to be the result of differences in days of frozen storage since other freshly prepared migratory fish examined contains group I abundantly.

Figure IV-6 shows the chromatograms of chum salmon. As it is evident from this Fig. IV-6, chum salmon under feeding migration are extremely rich in (16:0) (22:6) (see also Fig. IV-16 and Fig. IV-17).

Observations throughout Figs. IV-7~32 give information that the molecular species with the combinations of saturated fatty acids such as (16:0) (16:0) and (16:0) (18:0) are found only in big-eyed tuna. The reason why those are not found in other fish is considered that the melting point of (16:0) (16:0) or (16:0) (18:0) is higher than other molecular species observed so that the liquid crystal conformation of cell membrane composed of these saturated molecular species might be convenient for the warm environment and inconvenient for the cold environment.

It has been widely accepted that the amount of phospholipid of muscle is almost constant. But the expressions by mg/100 g muscle of each lecithin molecular species (Figs. IV-22 ~ 32) show that even the amount of lecithin changes in a considerable degree.

As it is observed throughout the figures, predominant molecular species are

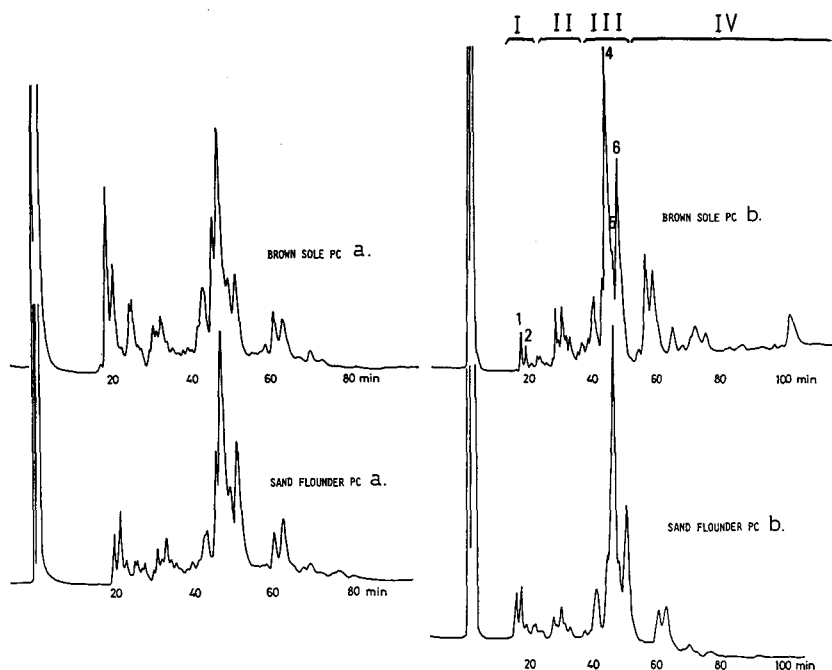

Fig. IV-3. HPLC chromatograms of brown sole and sand flounder muscle lecithin.
 a: Captured in 1982 b: Captured in 1983
 Numbers as in Fig. IV-1.

usually composed of 16:0, 18:1, 20:5 and 22:6 such as (20:5) (20:5), (20:5) (22:6), (22:6) (22:6), (18:1) (20:5), (18:1) (22:6), (16:0) (20:5), (16:0) (22:6) and (16:0) (18:1). Figure IV-33 illustrates the amount of (20:5) (20:5), (20:5) (22:6), (22:6) (22:6), (20:5) (18:1)+(18:1) (20:5), (22:6) (18:1)+(18:1) (22:6), (20:5) (16:0)+(16:0) (20:5), (22:6) (16:0)+(16:0) (22:6) and (18:1) (16:0)+(16:0) (18:1) by radar charts. These charts are shown in sequence of elution (clockwise) and the original data have been employed from Figs. IV-7~21. As it is evident from this Fig. IV-33, the predominant peaks composed of 16:0, 18:1, 20:5 and 22:6 well characterize the characteristics of each fish. Bottom fish such as brown sole and sand flounder is of outstanding owing to the ratio of (16:0) (20:5) and (16:0) (22:6). All other fish except Alaska pollack contains (16:0) (22:6) as the most predominant component while Alaska pollack contains both component almost equally. From the view point of seasonal variation, rainbow trout shows an extraordinary change. It is considered that the closed environment of this fish forced the changes of lecithin for the adaptation. Fatty fish such as sardine and mackerel also show considerable changes compared with other marine fish examined.

Section 3. Characterization of Each Fish by Principal Component Analysis

Principal component analysis (PCA) is well known as the most representative

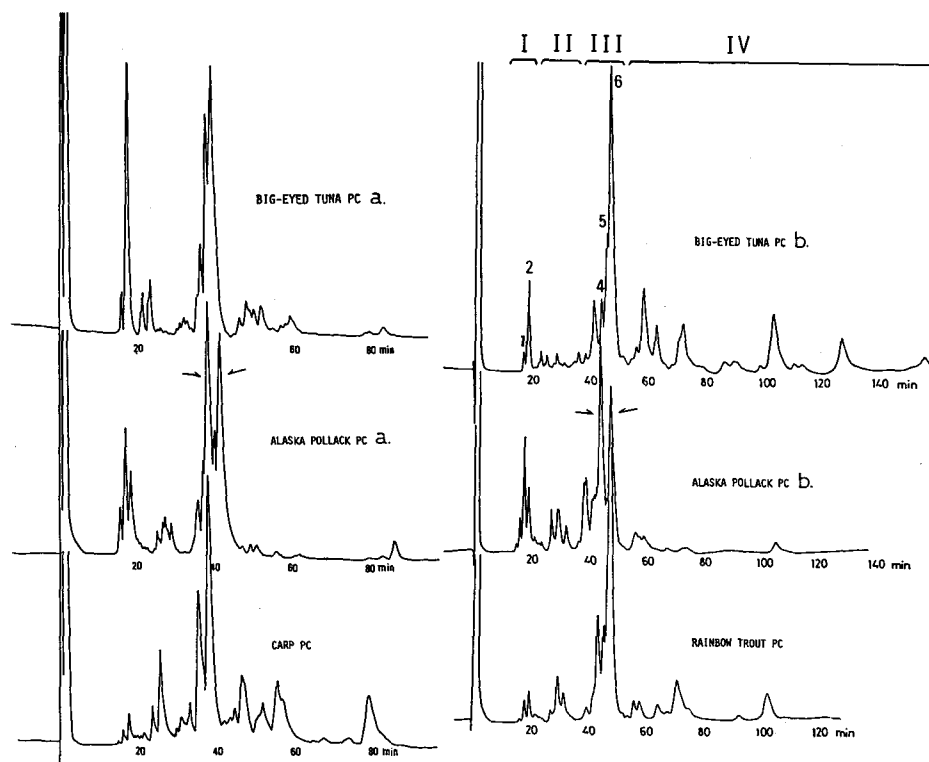

Fig. IV-4. HPLC chromatograms of big-eyed tuna, Alaska pollack, carp and rainbow trout muscle lecithin.

a : Captured in 1981, b : Captured in 1984 for Alaska pollack and a : Frozen 1981, b : Frozen 1983 for big-eyed tuna.

Carp is the sample of 1980 and rainbow trout is the sample of 1983.

Numbers as in Fig. IV-1.

way of multivariate analysis. PCA gives informations on all over relative relations of multivariate data of multiple samples at the same time.

Fig. IV-34 illustrates the dispersion of data on the second dimensional plane (X_1 , X_2 co-ordinate) as an example of explanation of PCA. If we consider new axes on the same plane such as Z_1 and Z_2 , the projection of each data (shown by arrow) on Z_1 axis well represents the characteristics of this set of data. Namely, we can decrease the dimension from second (plane) to first (line) with the smallest information loss. In this example, variates are only two. But if we expand this concept on multiple variate (multiple dimensions), and then if we decrease the dimension with the smallest information loss, such as, up to third or second dimension, this will become a so called PCA. In this study, the multiple dimension is decreased to second dimension for the ease of comprehension of the whole view of data. Fig. IV-35 shows how to interpret the print out from the computer on PCA analysis. The axis named as large number 1 is the first principal component and the axis named as large number 2 is the second principal component. First principal component has the meaning of "the axis that represents the data most," and second

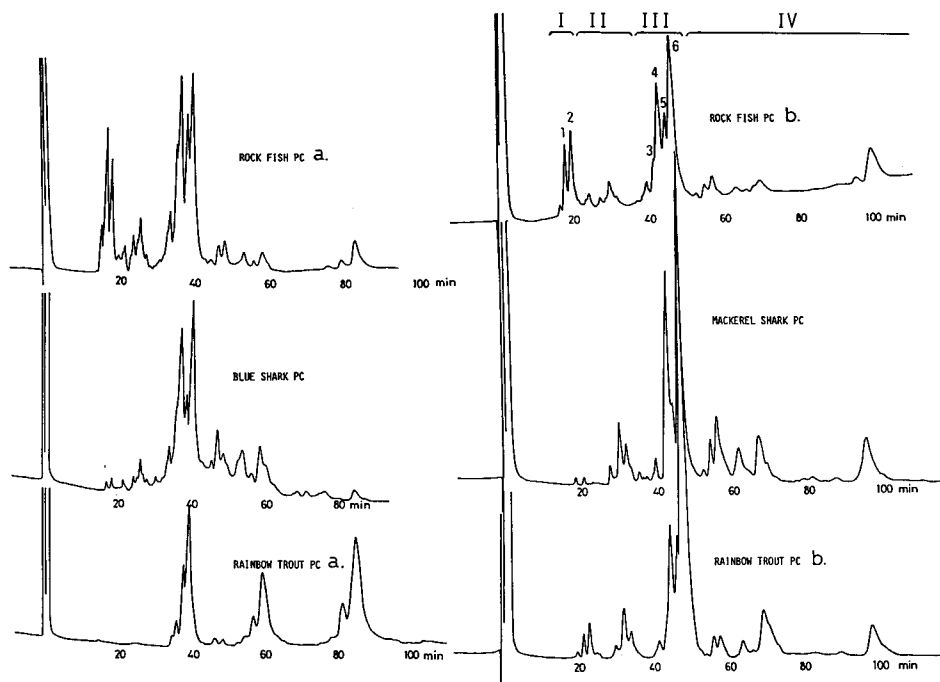

Fig. IV-5. HPLC chromatograms of rock fish, blue shark, mackerel shark and rainbow trout muscle lecithin.

a : Captured in 1982 b : Captured in 1983

Blue shark and mackerel shark are the samples of 1982.

Numbers as in Fig. IV-1.

principal component has the meaning of "the axis that represents the data next to the first principal component". Vectors shown as broken lines stand for component loadings. For example, suppose vector A stands for water content, B for protein content and C for lipid content, water content is almost negatively correlative with lipid content and at the same time, no correlation with protein content. Suppose if we have data number 1 and number 2, we can get the following informations :

Water content : number 1 > number 2

Lipid content : number 1 < number 2

Protein content : number 1 = number 2

By introducing this PCA, the whole view of all fish examined can be summarized in one or two planes with the minimum loss of information.

The computer program used for PCA was the modified program of "Personal Computer Library, Vol. 3"⁴⁸⁾. The original program was written for NEC PC-8001 personal computer. But it was modified for NEC PC-8801 mkII personal computer, for instance, the arrangement of the program was changed into N-88 BASIC, and the character mode was changed into graphic mode.

Table IV-6 shows the print out from the computer. In this Table, "Number of Variables 8" are the main molecular species which have been discussed on the radar

Table IV-6. Print out of mean and standard deviation of the amount of all fish muscle lecithin examined, and print outs of correlation matrix among the main molecular species, eigenvalues as well as contributions and finally component loadings

*****PRINCIPAL COMPONENT ANALYSIS*****

Number of Variables 8

Number of Sample 26

VARIABLE	MEAN	S.D.
1	3.539	5.895
2	19.969	38.480
3	22.352	39.263
4	23.121	57.776
5	8.587	15.364
6	39.974	46.670
7	93.237	76.259
8	11.161	22.591

<Correlation Matrix>

	1	2	3	4	5	6	7	8
1	1.000							
2	0.455	1.000						
3	0.279	0.965	1.000					
4	0.434	0.980	0.935	1.000				
5	0.170	-0.052	-0.019	-0.031	1.000			
6	0.503	0.030	-0.139	-0.011	-0.052	1.000		
7	0.361	0.802	0.784	0.755	-0.080	0.307	1.000	
8	-0.197	-0.112	-0.106	-0.075	-0.101	-0.181	-0.034	1.000

TRACE = 8

COMPONENT	*EIGENVALUE	%	ACC. %
1	3.860	48.252	48.252
2	1.532	19.155	67.407
3	1.088	13.602	81.009
4	0.874	10.929	91.938
5	0.472	5.906	97.843
6	0.133	1.658	99.501
7	0.036	0.446	99.947
8	0.004	0.053	100.000

**<COMPONENT LOADING>

	COMPONENT							
	1	2	3	4	5	6	7	8
1	0.540	0.649	0.039	0.231	0.464	0.128	0.008	0.005
2	0.983	-0.136	0.028	-0.022	0.059	-0.087	0.034	-0.052
3	0.935	-0.299	0.114	-0.074	-0.041	-0.014	0.126	0.032
4	0.958	-0.171	0.053	0.009	0.095	-0.159	-0.123	0.021
5	-0.024	0.243	0.854	0.407	-0.212	-0.028	-0.002	-0.002
6	0.160	0.838	-0.413	0.110	-0.248	-0.165	0.029	0.005
7	0.873	0.030	-0.200	0.082	-0.367	0.233	-0.047	-0.003
8	-0.155	-0.461	-0.360	0.794	0.042	-0.026	0.014	0.001

* Eigenvalues were calculated by the Jacobi method.

** Component loading corresponds to the scalar of the eigenvector on PCA.

The row and the column are variable numbers same with those in the footnote of Fig. IV-36.

Table IV-7. Print out of the principal loading (component score) of each fish on PCA
 <PRINCIPAL LOADING>

	PRINCIPAL							
	1	2	3	4	5	6	7	8
1	16.821	-2.524	0.185	-0.190	0.270	-0.056	-0.015	0.002
2	2.228	-1.392	0.073	-0.592	0.269	-0.050	0.002	-0.008
3	1.467	0.958	-0.880	-0.464	-0.499	0.074	0.113	-0.006
4	-1.526	-0.714	0.478	-0.705	0.140	0.003	0.043	0.002
5	-1.489	-0.246	-0.368	-0.503	0.053	-0.100	0.020	0.004
6	0.151	0.536	3.374	1.515	-0.849	-0.129	-0.012	-0.002
7	-0.810	-0.248	-0.373	0.264	-0.347	-0.013	0.050	0.005
8	0.198	0.315	1.597	0.490	-0.836	0.010	-0.018	-0.000
9	-1.240	-0.655	0.715	-0.310	-0.173	0.055	0.045	0.012
10	-2.616	-0.746	0.241	-0.569	0.276	-0.042	-0.019	-0.002
11	1.607	3.878	1.328	1.226	1.545	0.156	0.007	0.002
12	-2.224	-0.105	-0.034	-0.402	0.052	-0.164	-0.019	0.002
13	-0.773	1.472	-0.742	-0.400	0.136	-0.148	-0.015	-0.000
14	-1.787	0.511	-0.326	-0.624	0.297	-0.133	-0.015	0.001
15	-1.540	-0.215	0.244	-0.223	0.237	-0.011	0.005	-0.005
16	-2.454	-0.635	0.123	-0.640	0.320	-0.065	-0.009	-0.002
17	5.297	4.346	-2.244	0.512	-0.650	-0.086	-0.005	0.000
18	-1.100	0.453	0.285	-0.200	0.128	-0.144	-0.014	0.000
19	0.382	-0.550	0.022	-0.371	-0.232	0.465	-0.022	0.001
20	-0.608	-0.193	0.462	-0.055	0.096	0.105	0.017	-0.010
21	-1.260	-0.513	0.417	-0.401	0.082	0.070	0.019	0.002
22	-1.550	0.282	-0.457	-0.646	-0.118	0.050	-0.039	-0.001
23	-0.667	0.204	-1.129	0.214	-0.500	0.177	-0.073	0.000
24	-2.052	-0.663	-0.545	-0.052	0.061	-0.057	-0.026	0.002
25	-2.843	-2.996	-1.932	3.310	0.288	-0.026	0.017	-0.001
26	-1.610	-0.561	-0.515	-0.185	-0.046	0.059	-0.033	0.000

Row

- | | |
|---|---|
| 1. Sardine PC(Dark muscle), July 1982 | 2. Sardine PC(Dark muscle), Oct. 1983 |
| 3. Sardine PC(White muscle), July 1982 | 4. Sardine PC(White muscle), Oct. 1983 |
| 5. Mackerel PC(Dark muscle), July 1982 | 6. Mackerel PC(Dark muscle), Oct. 1983 |
| 7. Mackerel PC(White muscle), July 1982 | 8. Mackerel PC(White muscle), Oct. 1983 |
| 9. Big-eyed tuna PC, Frozen 1981 | 10. Big-eyed tuna PC, Frozen 1983 |
| 11. Brown sole PC, Oct. 1982 | 12. Brown sole PC, May 1983 |
| 13. Sand flounder PC, Dec. 1982 | 14. Sand flounder PC, May 1983 |
| 15. Rock fish PC, Oct. 1982 | 16. Rock fish PC, July 1983 |
| 17. Alaska pollack PC, Dec. 1981 | 18. Alaska pollack PC, Jan. 1984 |
| 19. Chum salmon PC, Male, June 1980 | 20. Chum salmon PC, Male, Aug. 1983 |
| 21. Chum salmon PC, Female, Aug. 1983 | 22. Blue shark PC, June 1982 |
| 23. Mackerel shark PC, July 1982 | 24. Carp PC, Sep. 1980 |
| 25. Rainbow trout PC, Sep. 1982 | 26. Rainbow trout PC, May 1983 |

Column

- | | | |
|--|--|---------------------|
| 1. (20 : 5)(20 : 5) | 2. (20 : 5)(22 : 6) | 3. (22 : 6)(22 : 6) |
| 4. (20 : 5)(18 : 1) + (18 : 1)(20 : 5) | 5. (22 : 6)(18 : 1) + (18 : 1)(22 : 6) | |
| 6. (20 : 5)(16 : 0) + (16 : 0)(20 : 5) | 7. (22 : 6)(16 : 0) + (16 : 0)(22 : 6) | |
| 8. (18 : 1)(16 : 0) + (16 : 0)(18 : 1) | | |

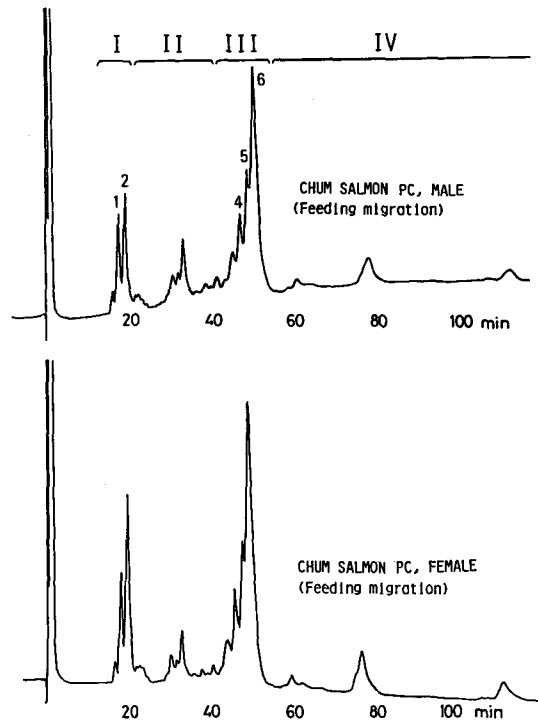

Fig. IV-6. HPLC chromatograms of chum salmon muscle lecithin. Both are the samples of 1983. Numbers as in Fig. IV-1.

chart in Fig. IV-33, namely, those corresponds to the footnote in Table IV-7 shown as "Column". "Number of Sample 26" are the fish examined and those are also shown in the footnote of Table IV-7. "MEAN" is the average amount of each molecular species mg/100 g muscle. "S.D." is standard deviation. "Correlation Matrix" shows the correlation of each variable (molecular species). "EIGENVALUE" is calculated by the Jacobi method from correlation matrix. "%" shows the contribution for the information of the whole data of each principal component and "ACC.%" is the accumulative value of these "%". "<COMPONENT LOADING>" is the scalar of the eigenvector (see Fig. IV-35).

In Fig. IV-36, eigenvectors of major molecular species are shown as small numbers on the first and second principal component plane. These are drawn up from the print out of "<COMPONENT LOADING>" in columns 1 and 2 in Table IV-6. And in Fig. IV-37, eigenvectors of the same molecular species are generated on the first and third principal component plane. And these are drawn up from the print out of "<COMPONENT LOADING>" in columns 1 and 3 in Table IV-6.

"<PRINCIPAL LOADING>" in Table IV-7 is the print out of principal loading of each fish which shows the position on the PCA plane. For example, the cell in the 1-th row, the 1-th column shows the distance on the first principal component, and the cell in the 1-th row, the 2-th column shows the distance on the second

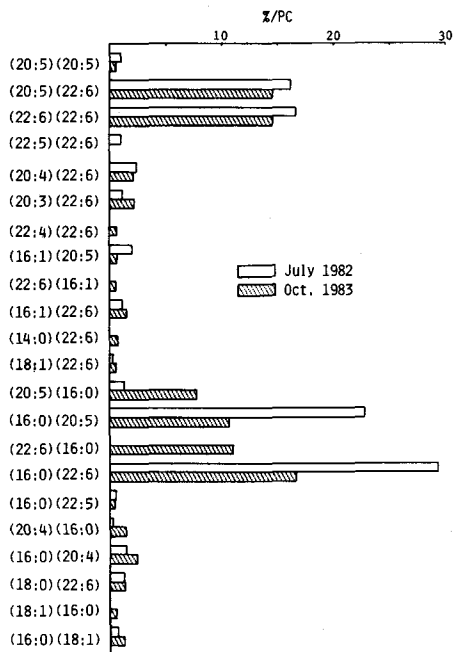

Fig. IV-7. Molecular species composition of sardine dark muscle lecithin, in relative %.

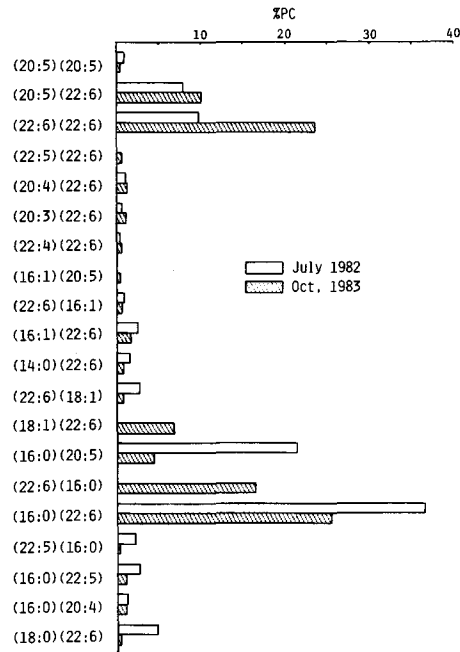

Fig. IV-8. Molecular species composition of sardine white muscle lecithin, in relative %.

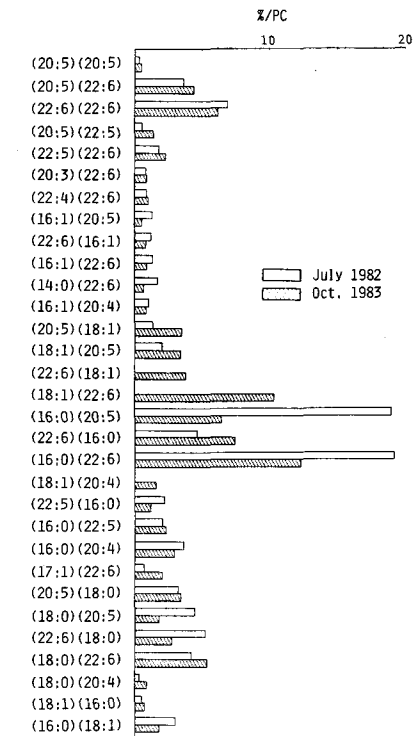

Fig. IV-9. Molecular species composition of mackerel dark muscle lecithin, in relative %.

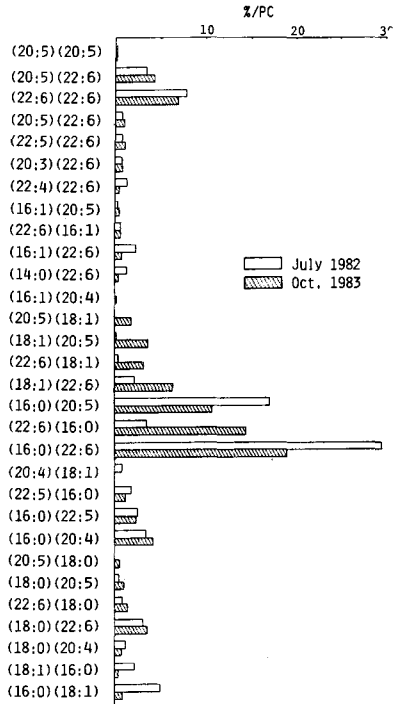

Fig. IV-10. Molecular species composition of mackerel white muscle lecithin, in relative %.

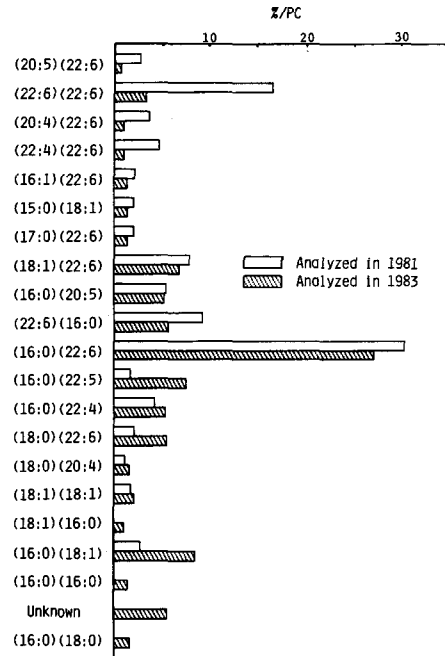

Fig. IV-11. Molecular species composition of big-eyed tuna muscle lecithin, in relative %.

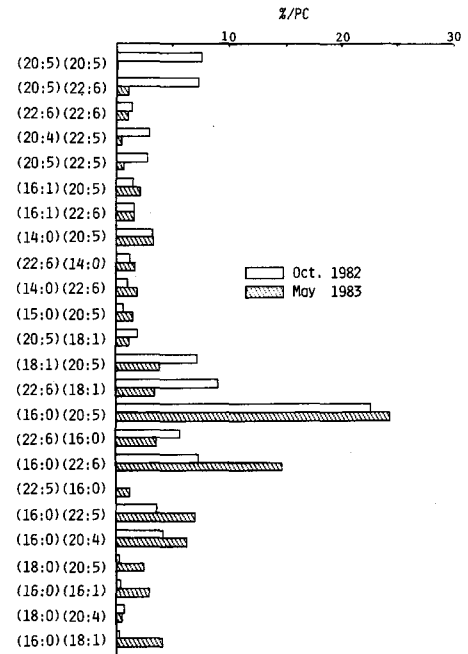

Fig. IV-12. Molecular species composition of brown sole muscle lecithin, in relative %.

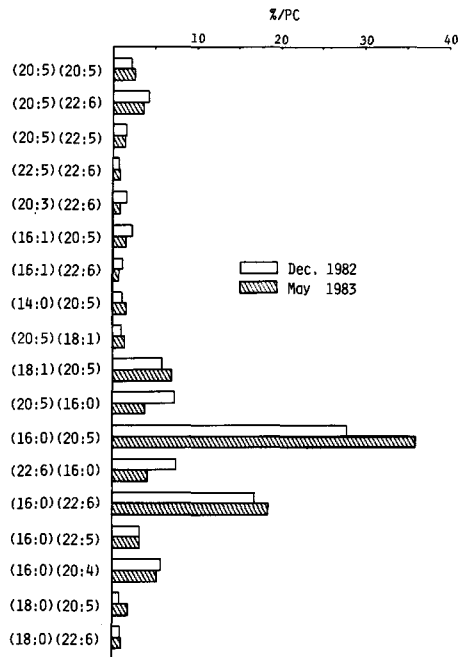

Fig. IV-13. Molecular species composition of sand flounder muscle lecithin, in relative %.

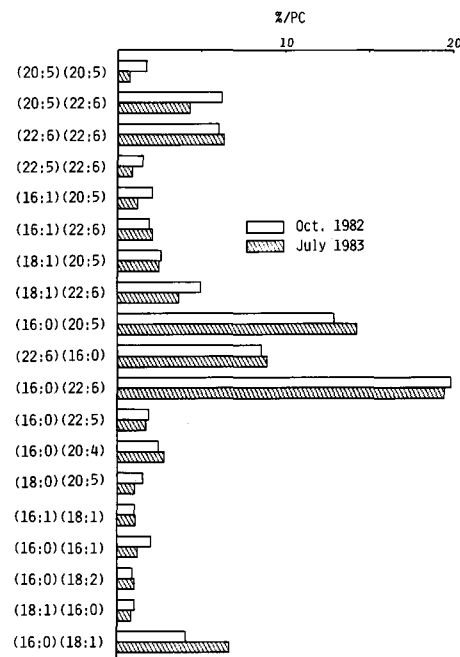

Fig. IV-14. Molecular species composition of rock fish muscle lecithin, in relative %.

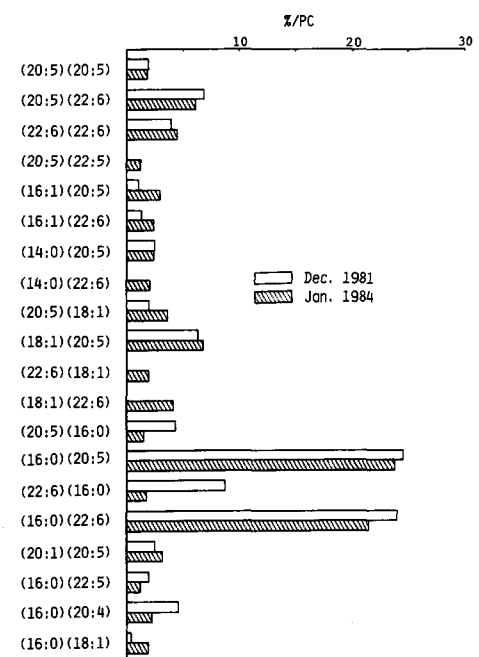

Fig. IV-15. Molecular species composition of Alaska pollack muscle lecithin, in relative %.

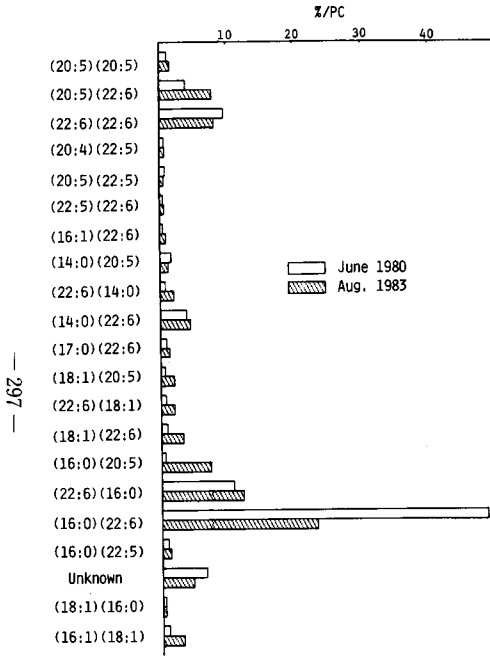

Fig. IV-16. Molecular species composition of male chum salmon muscle lecithin at the stage of feeding migration, in relative %.

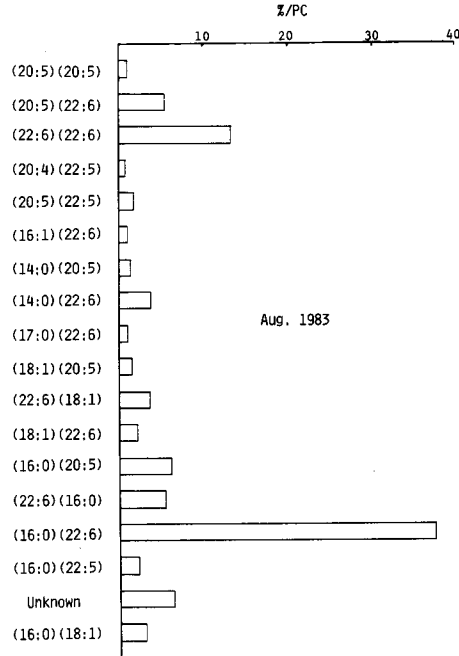

Fig. IV-17. Molecular species composition of female chum salmon muscle lecithin at the stage of feeding migration, in relative %.

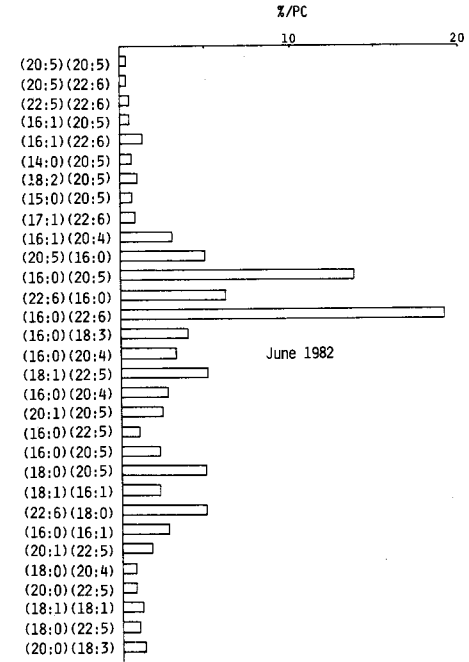

Fig. IV-18. Molecular species composition of blue shark muscle lecithin, in relative %.

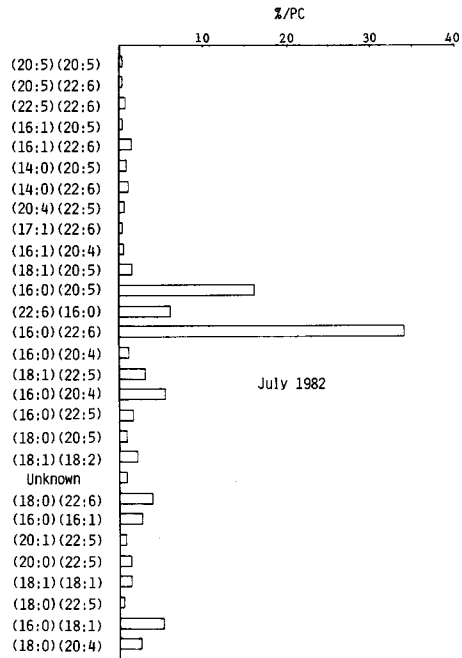

Fig. IV-19. Molecular species composition of mackerel shark muscle lecithin, in relative %.

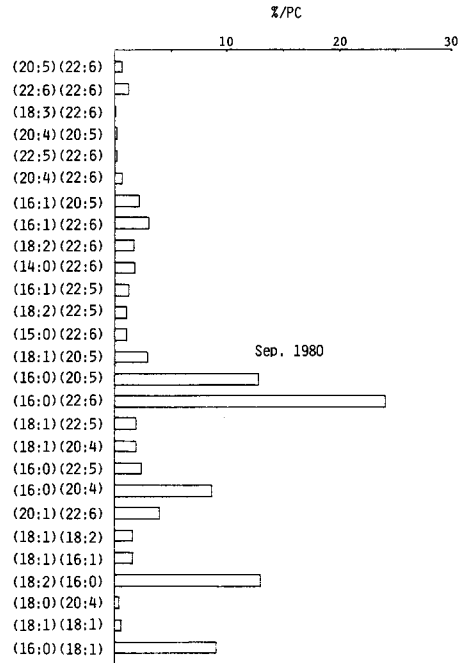

Fig. IV-20. Molecular species composition of carp muscle lecithin, in relative %.

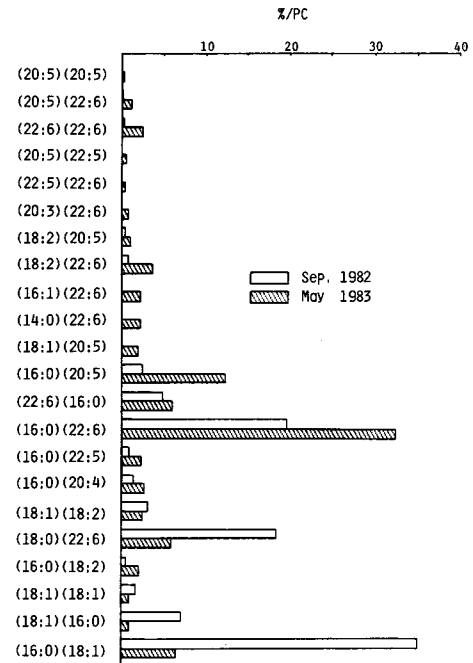

Fig. IV-21. Molecular species composition of rainbow trout muscle lecithin, in relative %.

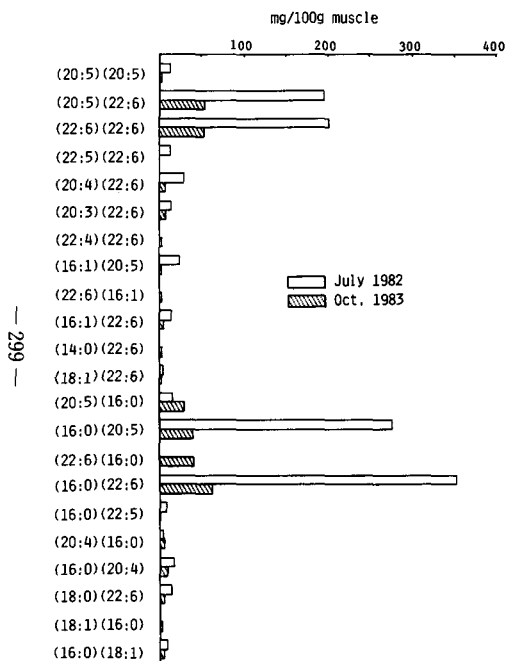

Fig. IV-22. Amount of each molecular species of sardine dark muscle lecithin, in mg/100 g muscle.

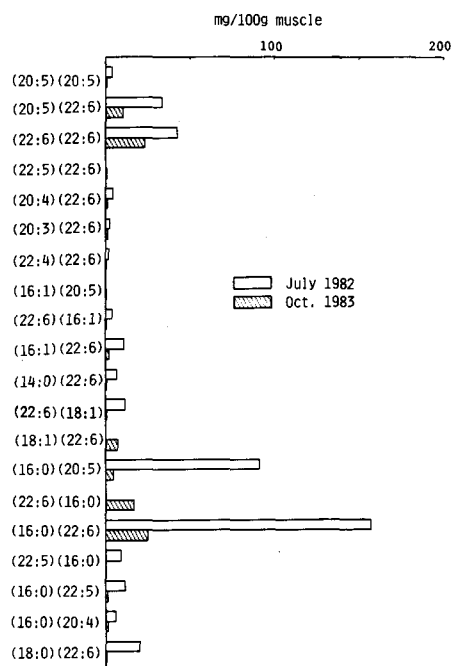

Fig. IV-23. Amount of each molecular species of sardine white muscle lecithin, in mg/100 g muscle.

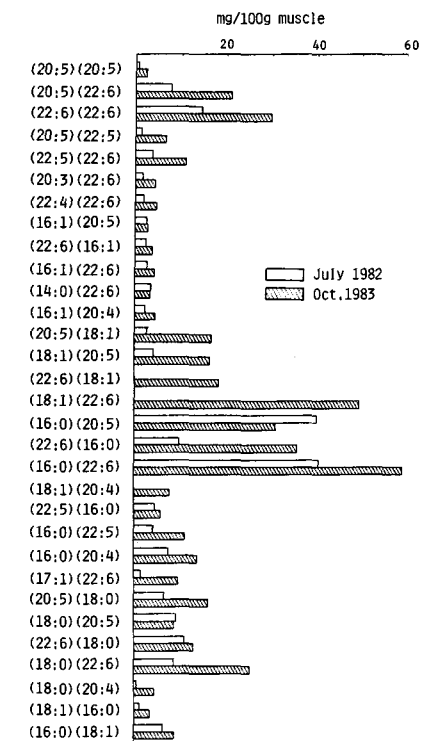

Fig. IV-24. Amount of each molecular species of mackerel dark muscle lecithin, in mg/100 g muscle.

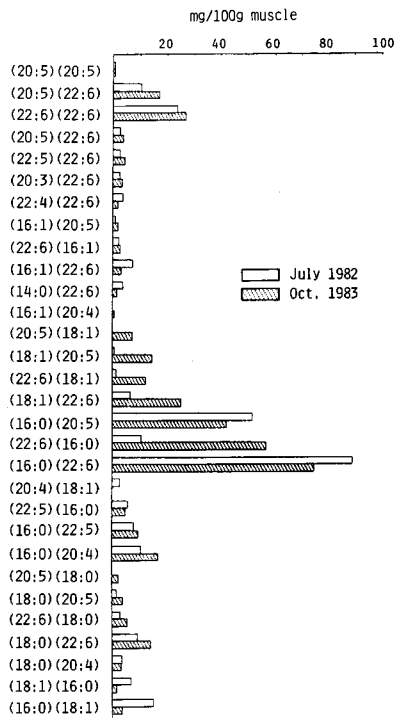

Fig. IV-25. Amount of each molecular species of mackerel white muscle lecithin, in mg/100 g muscle.

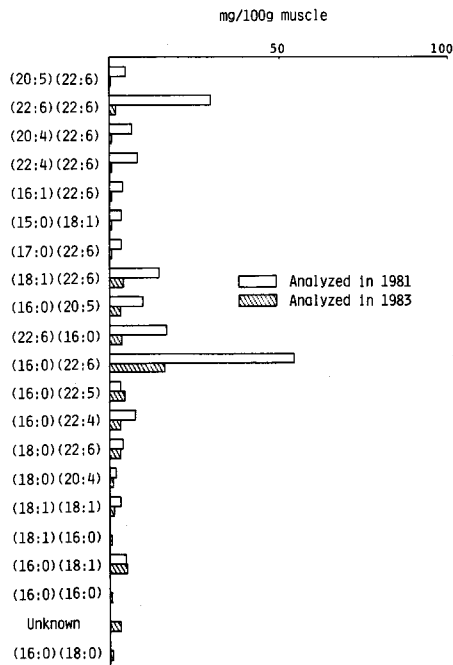

Fig. IV-26. Amount of each molecular species of big-eyed tuna muscle lecithin, in mg/100 g muscle.

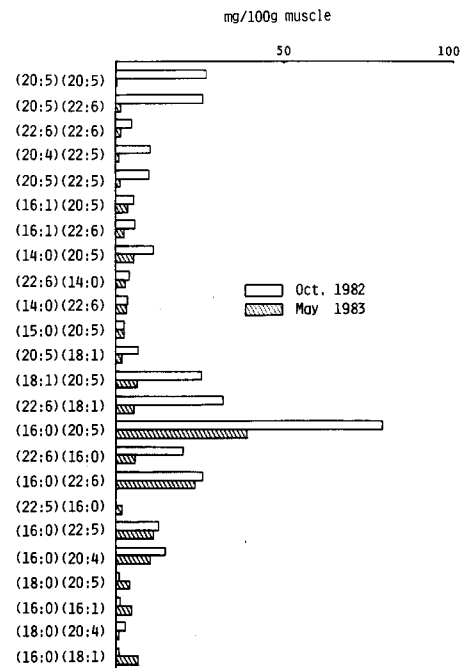

Fig. IV-27. Amount of each molecular species of brown sole muscle lecithin, in mg/100 g muscle.

301

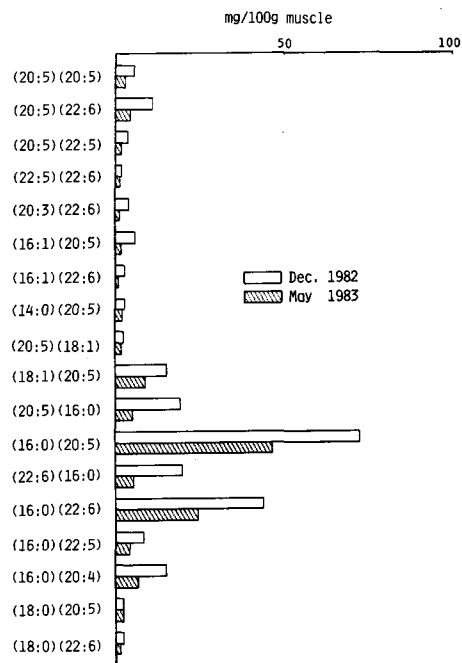

Fig. IV-28. Amount of each molecular species of sand flounder muscle lecithin, in mg/100 g muscle.

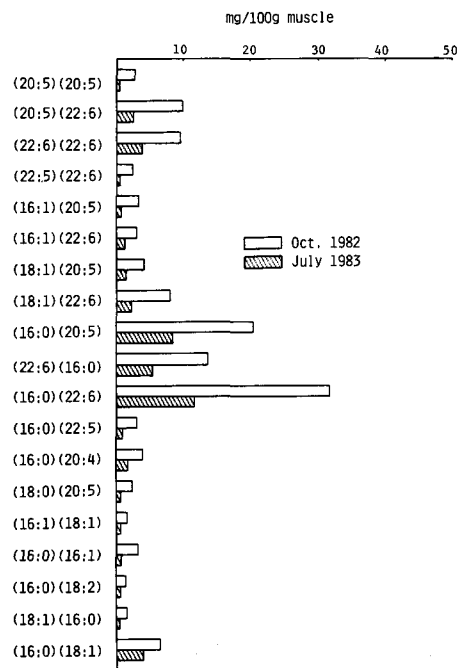

Fig. IV-29. Amount of each molecular species of rock fish muscle lecithin, in mg/100 g muscle.

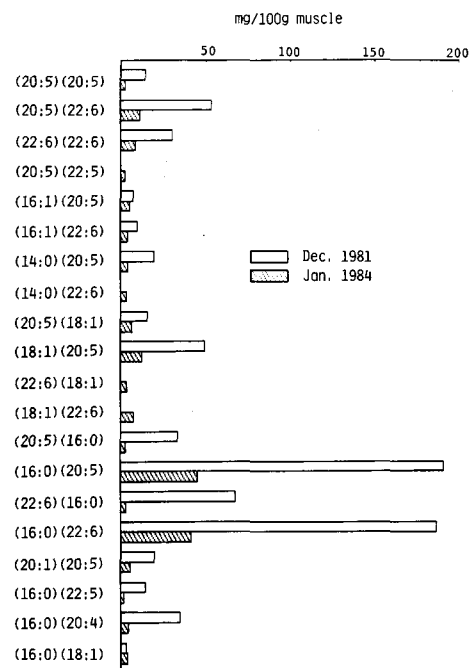

Fig. IV-30. Amount of each molecular species of Alaska pollack muscle lecithin, in mg/100 g muscle.

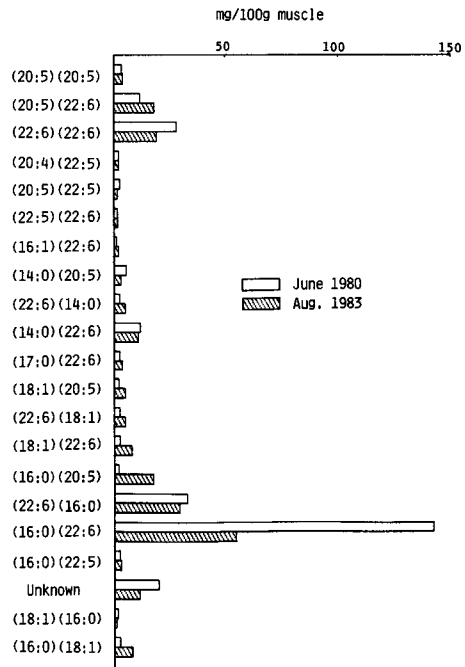

Fig. IV-31. Amount of each molecular species of male chum salmon muscle lecithin, in mg/100 g muscle, at the stage of feeding migration.

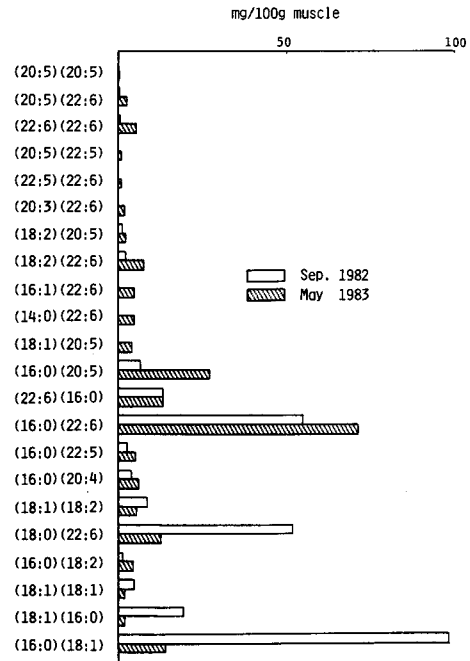

Fig. IV-32. Amount of each molecular species of rainbow trout muscle lecithin, in mg/100 g muscle.

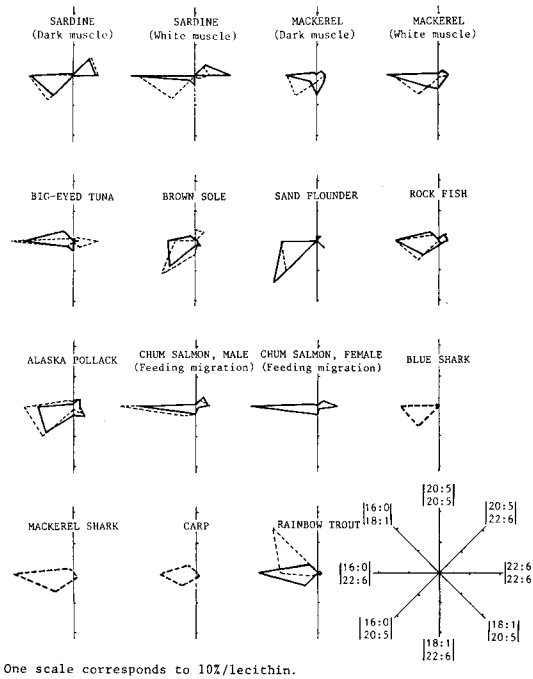

Fig. IV-33. Radar charts of major molecular species of fish muscle lecithin, in relative %.
Solid lines are the ones captured in 1983~1984, and the broken lines are the ones captured in 1980~1982.

principal component. These principal loadings were plotted on the first and second principal component plane as shown in Figs. IV-38~40 and on the first and third principal component plane as shown in Figs. IV-44~46 in different scales. Eigenvector of Fig. IV-36 is for Fig. IV-38 and that of Fig. IV-37 is for Fig. IV-44. As shown in Fig. IV-38, sardine dark muscle has a drastic seasonal change (points number 1 and number 2). And among the white flesh fish, Alaska pollack has a large seasonal change (points number 17 and number 18). The movement of point number 1 to point number 2 is the direction of eigenvector number 4 that shows the direction of $(20:5)(18:1) + (18:1)(20:5)$ combinations. So we might say that sardine dark muscle has a large seasonal variation in the molecular species composed of 20:5 and 18:1.

Fig. IV-39 is the magnified figure of Fig. IV-38. And Fig. IV-40 is the further magnified figure of Fig. IV-39. From these two Figures i.e. Fig. IV-39 and Fig. IV-40, generally speaking, there seems to be a direction on the axis of oval shape shown in the movement between the same fish except in the cases of sardine dark muscle, chum salmon and rainbow trout. This direction coincide with eigenvector of $(20:5)(20:5)$. Though, further supplementary studies should be done to be conclusive, it is assumed that $(20:5)(20:5)$ is the most reflectable molecular species against seasonal variations among the majority of fish. This is more evidently shown in Figs. IV-41~43 in three different scales, and only sardine dark muscle

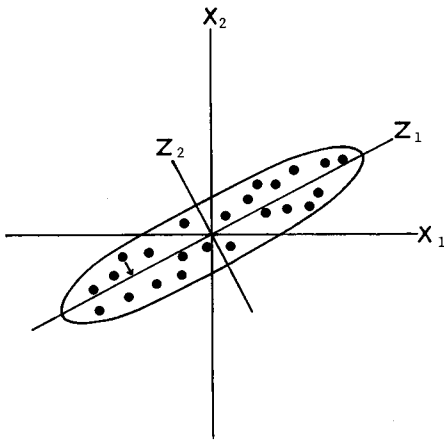
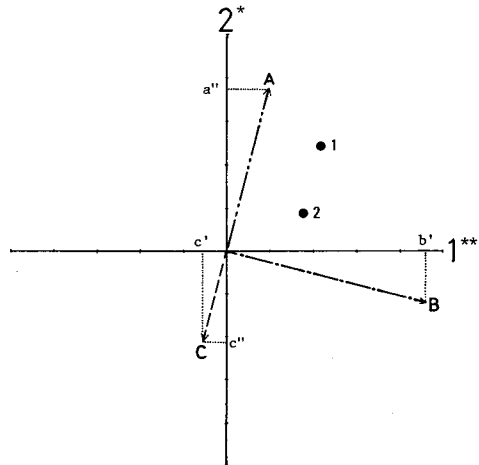

Fig. IV-34. Simplest form of PCA as an example.

The arrow shows the projection of each data on the axis of first principal component.

This Fig. is quoted from "*Tahenryo Kaisekiho*" written by T. Okuno, H. Kume, T. Haga and T. Yoshizawa.

Published by Nikkagiren Shuppan-sya, Tokyo, 1977, 14 pp. (In Japanese).



Component A: Number 1 > Number 2

Component B: Number 1 = Number 2

Component C: Number 1 < Number 2

* Second principal component.

** First principal component.

a'': Scalar of the eigenvector of component A on second principal component.
 b': Scalar of the eigenvector of component B on first principal component.
 c': Scalar of the eigenvector of component C on first principal component.
 c'': Scalar of the eigenvector of component C on second principal component.

Fig. IV-35. Interpretation of the results of PCA as an example.

(shown as A), chum salmon (shown as B) and rainbow trout (shown as C) have different directions. As it is well known, the general characteristics of these three fish are as follows :

- Sardine dark muscle : Drastic change in lipid content.
- Chum salmon : Migration from sea to river.
- Rainbow trout : Fresh water fish.

So, these characteristics might affect the molecular species of muscle lecithin.

Through Fig. IV-44 to Fig. IV-46 show the distribution of each fish on the first and third principal component plane. The outstanding deviated points are those of sardine dark muscle (point number 1) and Alaska pollack (point number 17) as it is seen in the first and second principal component plane. Those of rainbow trout and mackerel dark muscle also have a deviation in this plane, but not so large as it is in the cases of sardine dark muscle and Alaska pollack. Figure IV-47 through Fig. IV-49 show the seasonal variations by lines on the first and third principal component plane. It is hard to find a general movement of molecular species in this plane according to the seasonal variation unlike it is observed in the first and second principal component plane.

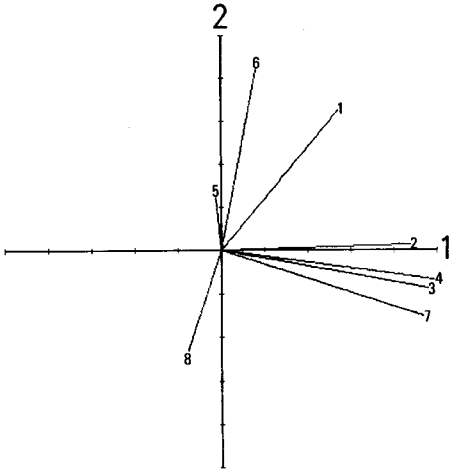

Fig. IV-36. Eigenvectors of major molecular species of fish muscle lecithin on the first and second principal component plane on PCA.

1. (20 : 5) (20 : 5)
2. (20 : 5) (22 : 6)
3. (22 : 6) (22 : 6)
4. (20 : 5) (18 : 1) + (18 : 1) (20 : 5)
5. (22 : 6) (18 : 1) + (18 : 1) (22 : 6)
6. (20 : 5) (16 : 0) + (16 : 0) (20 : 5)
7. (22 : 6) (16 : 0) + (16 : 0) (22 : 6)
8. (18 : 1) (16 : 0) + (16 : 0) (18 : 1)

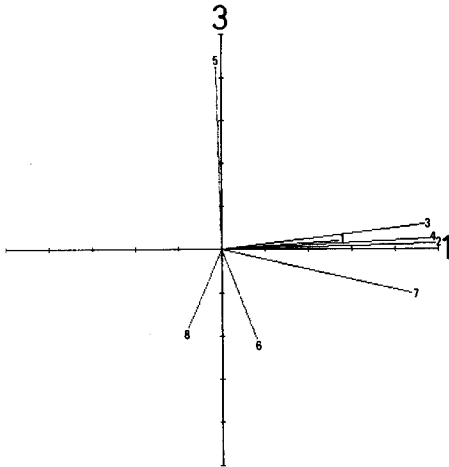

Fig. IV-37. Eigenvectors of major molecular species of fish muscle lecithin on the first and third principal component plane on PCA.

Eigenvector numbers as in Fig. IV-36.

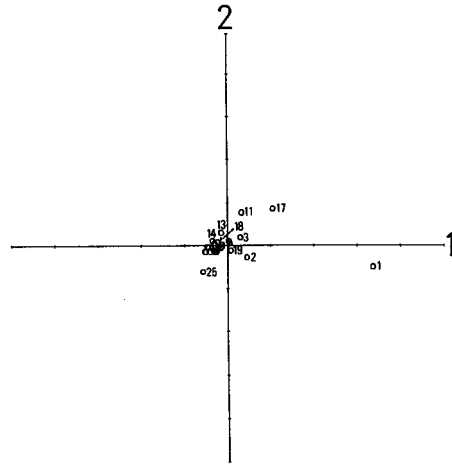

Fig. IV-38. Plots of principal loading of each fish on the first and second principal component plane on PCA.

Refer to the eigenvectors in Fig. IV-36 as background of this plane.

1. Sardine PC (Dark muscle), July 1982
2. Sardine PC (Dark muscle), Oct. 1983
3. Sardine PC (White muscle), July 1982
4. Sardine PC (White muscle), Oct. 1983
5. Mackerel PC (Dark muscle), July 1982
6. Mackerel PC (Dark muscle), Oct. 1983
7. Mackerel PC (White muscle), July 1982
8. Mackerel PC (White muscle), Oct. 1983
9. Big-eyed tuna PC, Frozen 1981
10. Big-eyed tuna PC, Frozen 1983
11. Brown sole PC, Oct. 1982
12. Brown sole PC, May 1983
13. Sand flounder PC, Dec. 1982
14. Sand flounder PC, May 1983
15. Rock fish PC, Oct. 1982
16. Rock fish PC, July 1983
17. Alaska pollack PC, Dec. 1981
18. Alaska pollack PC, Jan. 1984
19. Chum salmon PC, Male, June 1980
20. Chum salmon PC, Male, Aug. 1983
21. Chum salmon PC, Female, Aug. 1983
22. Blue shark PC, June 1982
23. Mackerel shark PC, July 1982
24. Carp PC, Sep. 1980
25. Rainbow trout PC, Sep. 1982
26. Rainbow trout PC, May 1983.

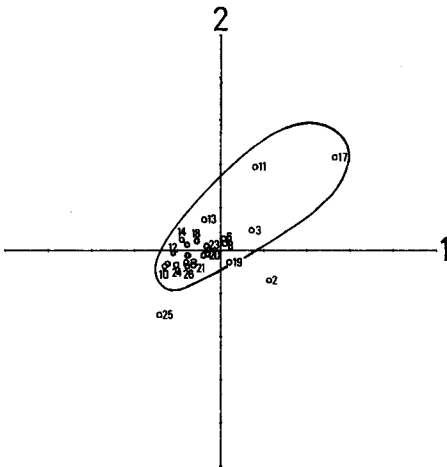

Fig. IV-39. Plots of principal loading of each fish on the magnified first and second principal component plane on PCA.
Refer to the eigenvectors in Fig. IV-36 as background of this plane.
Sample numbers as in Fig. IV-38.

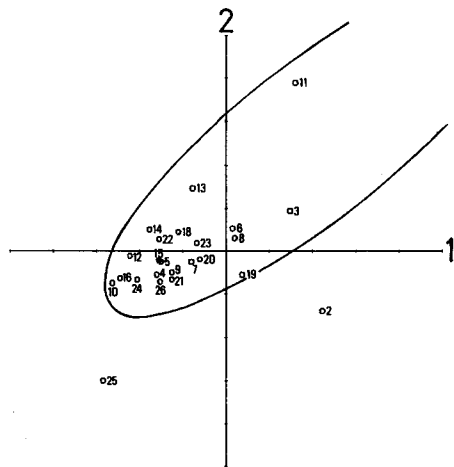

Fig. IV-40. Plots of principal loading of each fish on the highly magnified first and second principal component plane on PCA.
Refer to the eigenvectors in Fig. IV-36 as background of this plane.
Sample numbers as in Fig. IV-38.

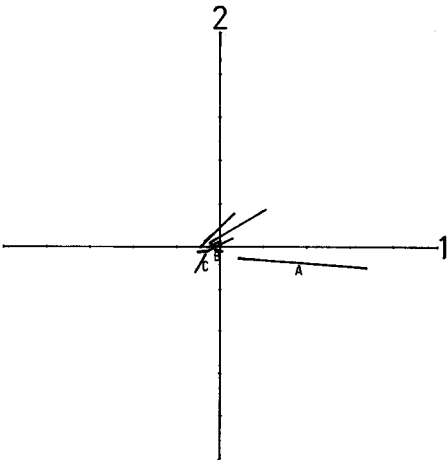

Fig. IV-41. Movement of the plots of each fish between the two different seasons on the same plane in Fig. IV-38.
Line A: Sardine PC (Dark muscle)
Line B: Chum salmon PC, Male
Line C: Rainbow trout PC

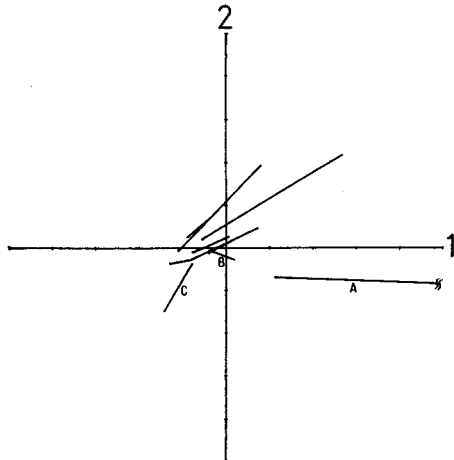

Fig. IV-42. Movement of the plots of each fish between the two different seasons on the same plane in Fig. IV-39.
Line A: Sardine PC (Dark muscle)
Line B: Chum salmon PC, Male
Line C: Rainbow trout PC

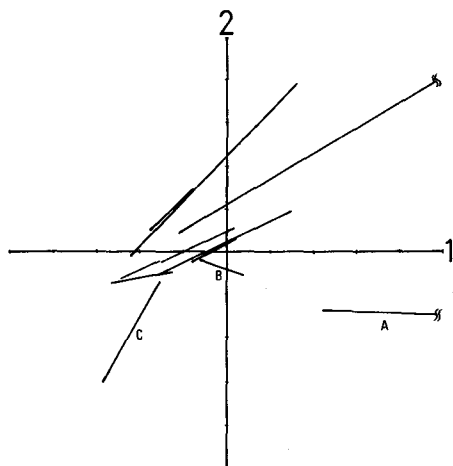

Fig. IV-43. Movement of the plots of each fish between the two different seasons on the same plane in Fig. IV-40.
 Line A : Sardine PC (Dark muscle)
 Line B : Chum salmon PC, Male
 Line C : Rainbow trout PC

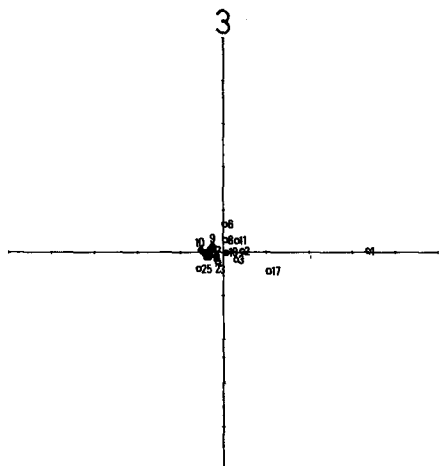

Fig. IV-44. Plots of principal loading of each fish on the first and third principal component plane on PCA.
 Refer to the eigenvectors in Fig. IV-37 as background of this plane.
 Sample numbers as in Fig. IV-38.

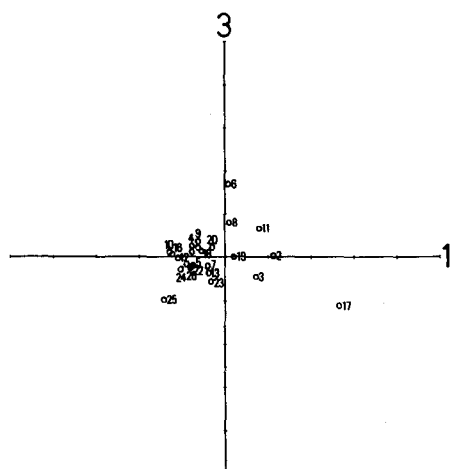

Fig. IV-45. Plots of principal loading of each fish on the magnified first and third principal component plane on PCA.
 Refer to the eigenvectors in Fig. IV-37 as background of this plane.
 Sample numbers as in Fig. IV-38.

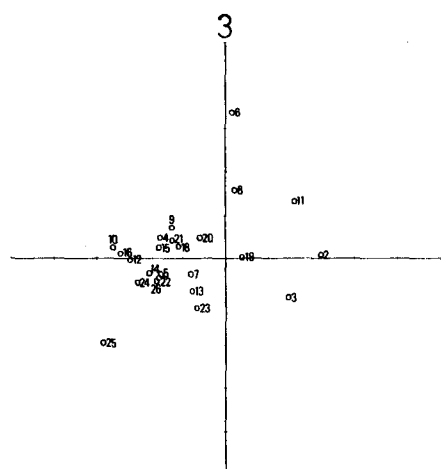

Fig. IV-46. Plots of principal loading of each fish on the highly magnified first and third principal component plane on PCA.
 Refer to the eigenvectors in Fig. IV-37 as background of this plane.
 Sample numbers as in Fig. IV-38.

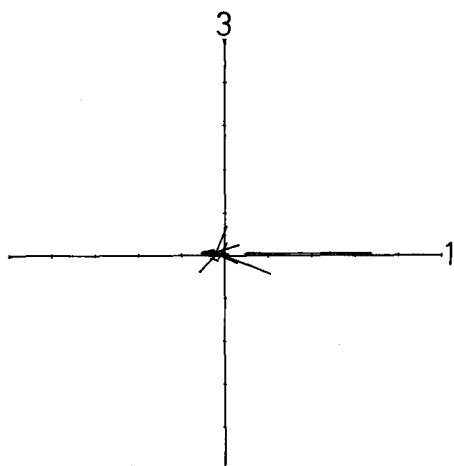

Fig. IV-47. Movement of the plots of each fish between the two different seasons on the same plane in Fig. IV-44.

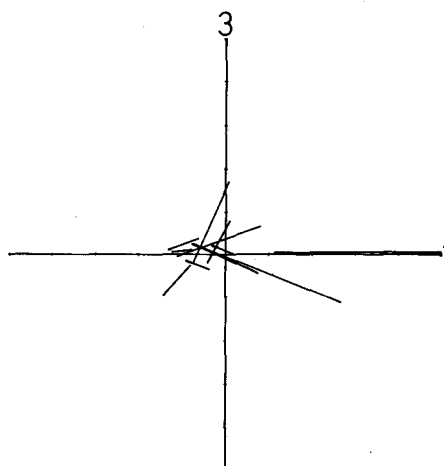

Fig. IV-48. Movement of the plots of each fish between the two different seasons on the same plane in Fig. IV-45.

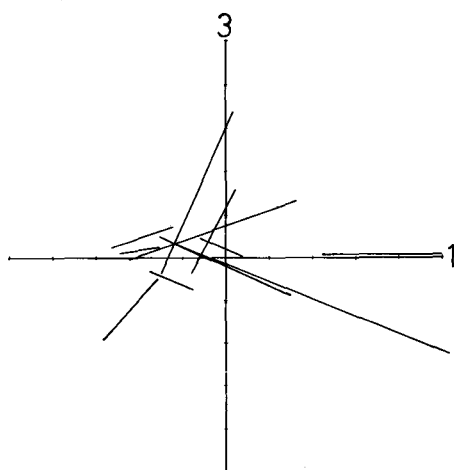

Fig. IV-49. Movement of the plots of each fish between the two different seasons on the same plane in Fig. IV-46.

Section 4. Changes in Fish Muscle Lecithin of Chum Salmon during Migration

Total lipids were obtained in the same way as described in section 1 from the fish muscle of chum salmon tabulated in Table IV-8. Lipid composition analysis as well as molecular species analysis were also done in the same manner as described in

Table IV-8. Chum salmon (*Oncorhynchus keta*) examined

Stage of migration and sex	Mean body length and weight Locality of catch	Date of catch
Feeding migration, Male	42.7 cm, 1367 g, 45°59' - 49°29' N, 167°07' - 175°30' E,	Aug. 1983
Feeding migration, Female	46.8 cm, 1593 g, 45°59' - 49°29' N, 167°07' - 175°30' E,	Aug. 1983
Spawning migration, Male Sea run	63.0 cm, 3267 g, Yakumo-cho, Hokkaido, Japan	Oct. 1983
Spawning migration, Female Sea run	64.3 cm, 3573 g, Yakumo-cho, Hokkaido, Japan	Oct. 1983
Spawning migration, Male River	73.0 cm, 5000 g, Yakumo-cho, Hokkaido, Japan	Nov. 1983
Spawning migration, Female River	70.0 cm, 4740 g, Yakumo-cho, Hokkaido, Japan	Nov. 1983
Spent, Male	74.2 cm, 5140 g, Yakumo-cho, Hokkaido, Japan	Nov. 1983
Spent, Female	72.7 cm, 4273 g, Yakumo-cho, Hokkaido, Japan	Nov. 1983

Table IV-9. Lipid composition of chum salmon muscle examined

Sample	Lipid	Yield*	Non-phospholipid**				Phospholipid**			PC mg/ 100 g muscle
			TG	FFA	ST	NP others	PC	PS+PE	PL others	
Feeding migration, Male		10.4	92.1	0.4	0.7	0.2	2.3	3.6	0.7	230
Feeding migration, Female		12.4	94.1	trace	0.7	0.7	1.3	2.9	0.3	161
Spawning migration, Male (Sea)		1.1	40.7	0.8	4.7	1.1	19.3	29.8	3.6	212
Spawning migration, Female (Sea)		1.4	49.9	trace	2.6	0.3	17.3	26.7	3.2	242
Spawning migration, Male (River)		1.3	40.7	5.7	6.2	trace	12.7	32.9	1.8	165
Spawning migration, Female (River)		1.6	41.5	2.6	15.5	0.1	9.2	28.1	3.0	147
Spent, Male		1.1	32.7	22.5	4.3	5.2	12.2	11.2	11.9	132
Spent, Female		0.9	11.6	19.9	7.8	5.5	19.1	15.9	20.2	172

See the abbreviations in the opening.

* g/100 g muscle. ** g/100 g total lipid.

Table IV-10. Fatty acid composition of diglyceride acetate derived from lecithin of chum salmon muscle

Sample Fatty acid	Feeding migration		Spawning migration				Spent	
	Male	Female	Male*	Female*	Male**	Female**	Male	Female
12:0	0.09			0.03			trace	0.06
14:0	4.58	3.10	1.98	2.78	3.34	3.74	3.49	3.53
15:0	0.82	0.68	0.37	0.42	0.42	0.44	0.37	0.32
16:0	29.02	32.26	30.02	26.84	23.95	28.61	29.51	26.15
16:1	1.79	1.38	1.66	2.19	2.60	2.56	2.41	1.83
17:0	1.14	0.92	0.43	0.38	0.61	0.50	0.35	0.48
17:1	0.44	0.37	0.25	0.16	0.36	0.25	0.42	0.27
18:0	1.03	1.11	0.72	0.59	1.23	0.52	1.45	0.83
18:1	8.43	8.27	6.40	4.68	5.04	7.25	9.65	6.64
18:2	0.51	0.52	0.37	0.51	0.94	0.64	0.60	0.46
19:1 or 18:4			0.46	0.63	0.97	0.97	0.34	0.39
19:2	0.69	0.56			1.36	1.19	0.33	0.49
20:0	1.01	0.77	0.67	0.79	3.27	trace	trace	0.79
20:1	0.10	0.10	0.39	0.29	2.29	0.52	1.11	0.05
20:2	0.11	0.09	0.06	0.04			0.33	0.14
20:3	0.65	0.58	0.13	0.13	0.06		0.93	0.88
20:4	0.79	0.67	1.54	1.83	3.00	1.80	0.41	0.51
20:5	11.49	10.18	15.00	16.22	19.00	23.66	15.87	16.96
22:3	0.07							
22:4	0.42	0.34	0.18	0.19				0.12
22:5	1.05	0.98	1.16	1.87	2.48	1.93	1.75	2.37
22:6	35.00	36.40	38.20	39.30	28.77	25.43	30.67	36.70
others	0.77	0.73	0.01	0.13	0.31		0.01	0.03

% in muscle lecithin.

* Sea run. ** River.

section 1. PCA analysis was done in the same way as described in section 1.

Table IV-9 shows the yield of total lipid and the percentage of each lipid class against total lipid. And on the right end of this table, the lecithin amounts/100 g muscle are shown. Though there is a drastic drop in the amount of total lipids and triglycerides between the stage of feeding migration and spawning migration, the amount of lecithin ranges between 161 ~ 230 mg/100 g muscle.

In Table IV-10, changes in fatty acid composition of diglyceride acetates (this represents the fatty acid composition of lecithin) during migration are shown. At the level of this analysis, not any significant differences are observed among the four stages.

HPLC chromatograms of each stage of migration are shown in Fig. IV-50 and

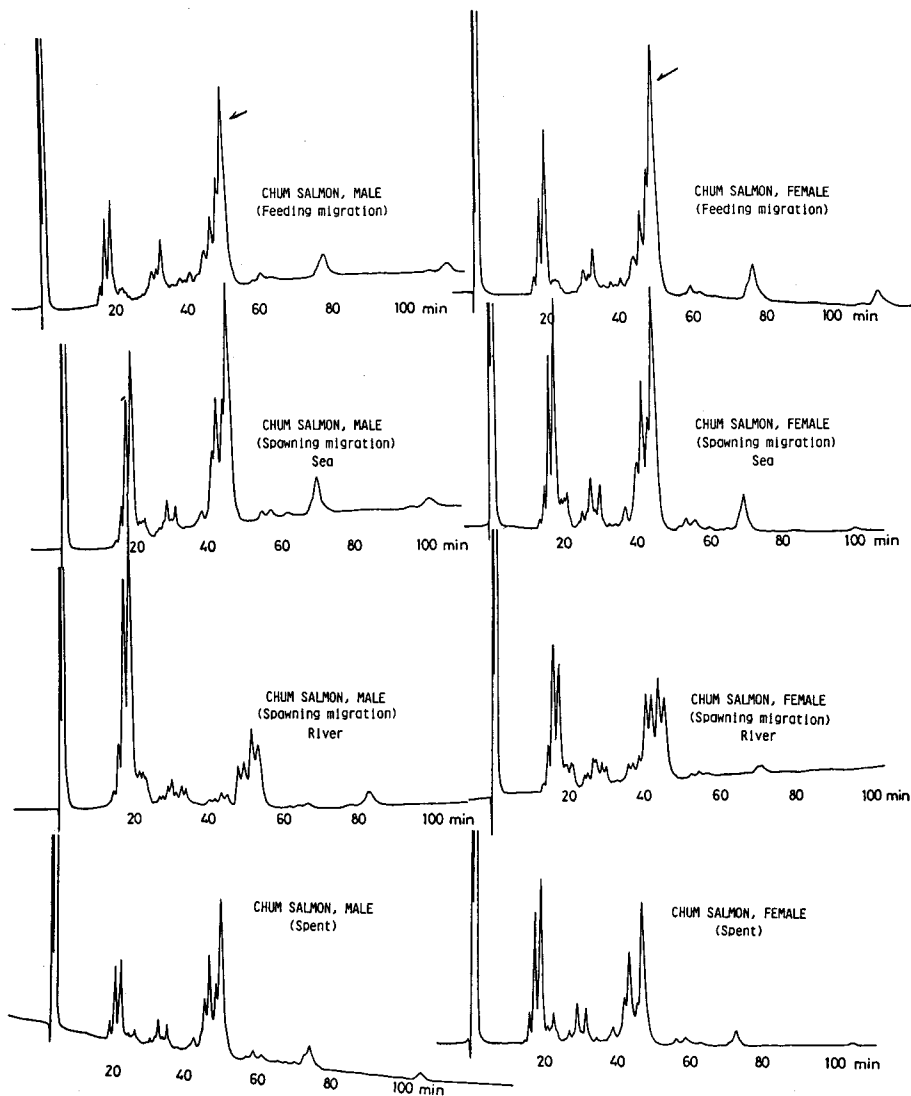

Fig. IV-50. HPLC chromatograms of chum salmon muscle lecithin on each stage of migration.

the appreciable amount molecular species of lecithin in sequence of elution on HPLC with the percentage data are shown in Figs. IV-51~54. As it is obviously seen in these figures chum salmon at the stage of feeding migration has (16:0) (22:6) as the most outstandingly predominant peak (shown by arrows in Fig. IV-50) compared with other three stages. At the stage of spawning migration, this peak i. e. (16:0) (22:6) becomes relatively smaller. Up to these two stages, the chromatographic patterns are analogous between male and female. When the fish starts ascending the river, drastic decrease in the amount of group III (see the footnote of

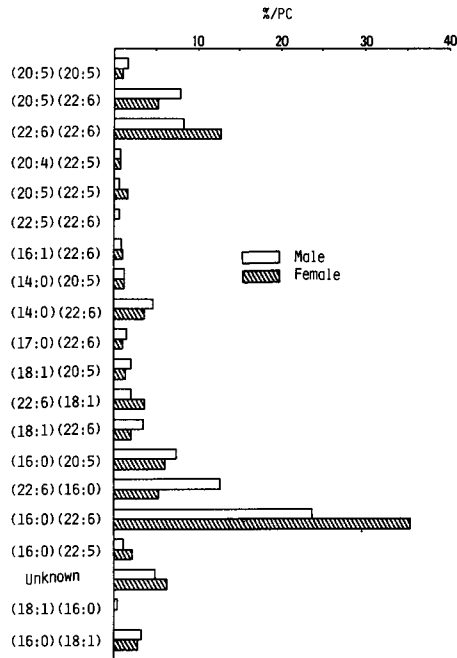

Fig. IV-51. Molecular species of chum salmon muscle lecithin at the stage of feeding migration.
(20 : 4) (22 : 5) is not sure.

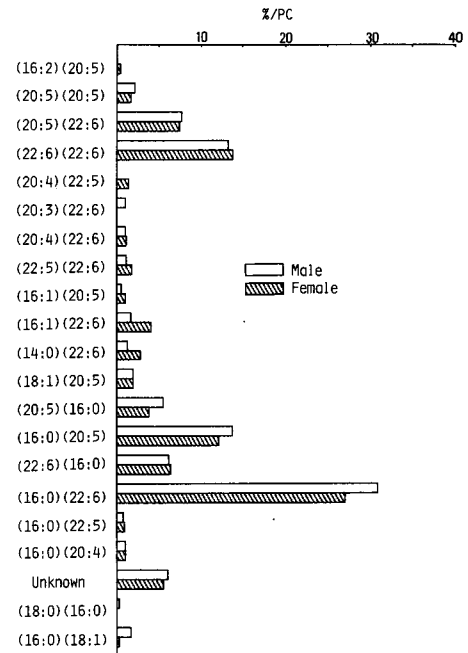

Fig. IV-52. Molecular species of chum salmon muscle lecithin at the stage of spawning migration (sea).
(14 : 0) (20 : 5), (17 : 0) (22 : 6), (20 : 5) (22 : 5) and (22 : 6) (18 : 1) are trace amount.
(20 : 4) (22 : 5) and (20 : 3) (22 : 6) are not sure.

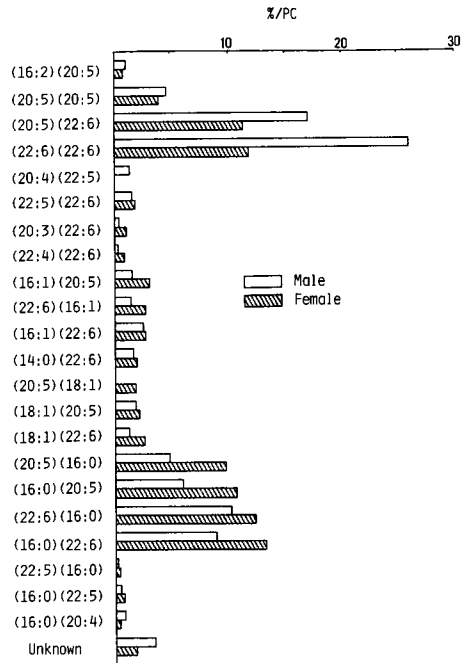

Fig. IV-53. Molecular species of chum salmon muscle lecithin at the stage of spawning migration (river).
 (14:0) (20:5), (17:0) (22:6) and
 (22:6) (18:1) are trace amount.
 (22:5) (22:6) is not sure.

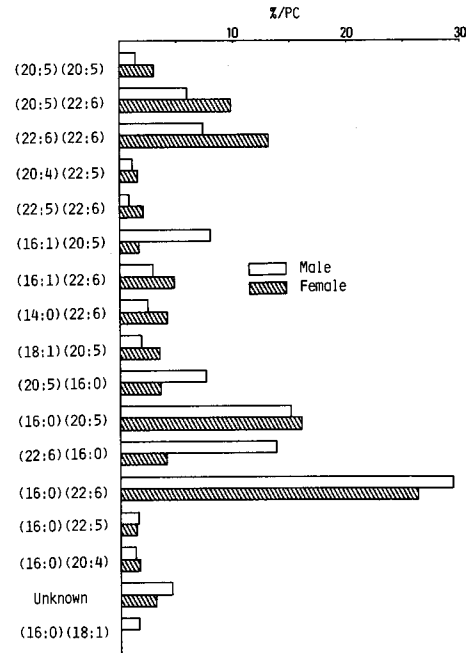

Fig. IV-54. Molecular species of chum salmon muscle lecithin at the stage of spent.
 (14:0) (20:5), (17:0) (22:6) and
 (22:6) (18:1) are trace amount.
 (20:4) (22:5) is not sure.

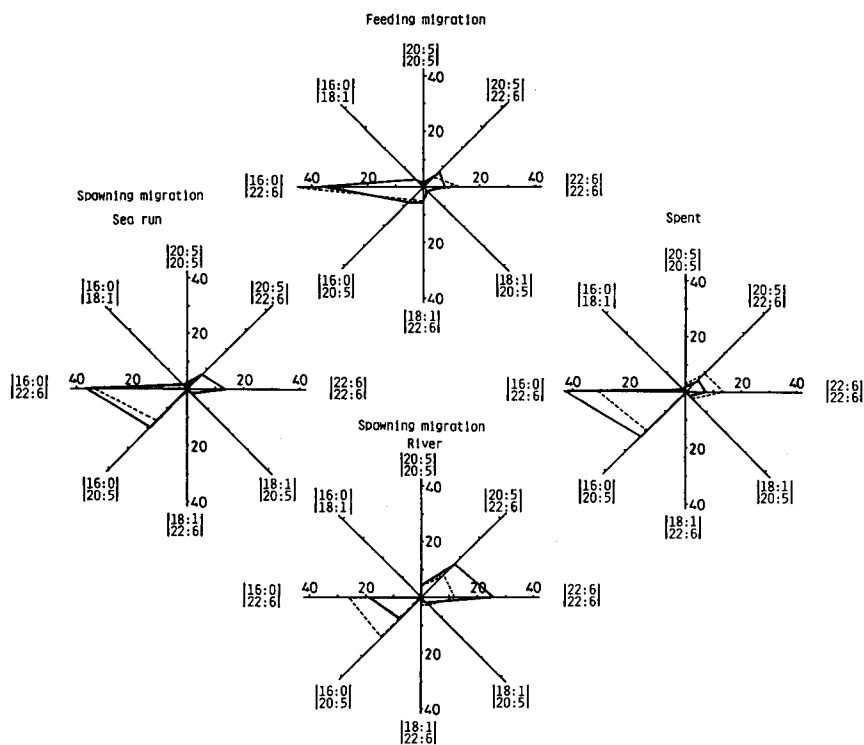

Fig. IV-55. Radar charts of major molecular species of chum salmon muscle lecithin on each stage of migration.
 — Male - - - - Female
 Scales are in %/PC.

Fig. IV-1 in section 2) especially the molecular species of (16 : 0) (22 : 6) and (16 : 0) (20 : 5) are observed. Unlike the chromatographic patterns at the stage of sea, outstanding differences are observed between male and female. The content of (22 : 6) (22 : 6) is extremely high followed by (20 : 5) (22 : 6) in male. Finally at the stage of spent salmon, (16 : 0) (22 : 6) as well as (16 : 0) (20 : 5) relatively increase compared with the former stage in the river. These are more concretely seen in radar charts of the main molecular species as illustrated in Fig. IV-55. The axes of these charts are the same with Fig. IV-33 in section 2. These charts are arranged in sequence of migration movement (anticlockwise). It is clearly seen from this figure that at the stage of sea run, slight differences in patterns of radar charts can be observed between male and female while that of river, outstanding differences are observed especially at the spawning stage. It is obviously seen from this Fig. IV-55 that the amount of (16 : 0) (20 : 5) is relatively very small in feeding migration stage compared with those of other three stages. The amount of (20 : 5) (22 : 6) and (22 : 6) (22 : 6) is surprisingly high at the river spawning stage.

The author has employed PCA again as discussed in the previous section. As it is shown in Table IV-11, number of variables which correspond to the number of

Table IV-11. Print out of mean and standard deviation of the amount of chum salmon muscle lecithin molecular species throughout all migratory stages

*****PRINCIPAL COMPONENT ANALYSIS*****

Number of Variables* 31

Number of Sample* 8

VARIABLE	MEAN	S.D.
1	0.474	0.681
2	4.163	1.861
3	16.050	6.058
4	23.849	10.126
5	1.563	1.148
6	0.640	1.186
7	0.531	0.831
8	0.515	1.020
9	0.628	1.182
10	1.549	1.568
11	0.227	0.475
12	3.076	4.453
13	0.785	1.519
14	4.548	2.561
15	0.635	1.201
16	5.148	2.699
17	0.633	1.270
18	0.331	0.936
19	3.678	0.907
20	1.279	2.385
21	2.105	2.739
22	7.587	5.567
23	19.627	7.958
24	16.170	7.630
25	45.032	19.780
26	0.115	0.223
27	2.051	0.879
28	1.387	1.039
29	8.357	3.925
30	0.195	0.368
31	2.369	2.691

* Variable numbers are shown in the footnote of Fig. IV-56 and samples are shown in the footnote of Table IV-15.

Table IV-12. Print out of the correlation matrix among the

<Correlation Matrix>

	1	2	3	4	5	6	7	8
1	1.000							
2	0.814	1.000						
3	0.772	0.904	1.000					
4	0.685	0.651	0.803	1.000				
5	0.162	-0.077	0.193	0.309	1.000			
6	0.843	0.818	0.628	0.356	-0.283	1.000		
7	0.203	0.479	0.255	0.200	-0.783	0.406	1.000	
8	-0.402	-0.576	-0.418	-0.230	-0.099	-0.311	-0.369	1.000
9	0.076	-0.015	0.096	0.436	0.209	-0.328	0.266	-0.307
10	-0.222	-0.222	-0.111	0.081	0.533	-0.609	-0.179	-0.399
11	0.667	0.609	0.335	0.025	-0.466	0.902	0.472	-0.276
12	-0.100	-0.213	-0.266	-0.349	0.163	-0.071	-0.205	-0.398
13	0.760	0.715	0.471	0.169	-0.398	0.967	0.455	-0.298
14	0.294	0.103	0.110	0.259	0.642	-0.121	-0.210	-0.627
15	-0.421	-0.434	-0.191	-0.263	-0.009	-0.326	-0.387	0.845
16	-0.415	-0.464	-0.168	-0.258	0.465	-0.555	-0.649	0.481
17	-0.397	-0.349	-0.094	-0.255	0.025	-0.307	-0.364	0.724
18	0.417	0.341	0.037	-0.259	-0.550	0.683	0.456	-0.204
19	-0.225	0.017	0.127	-0.009	0.398	-0.441	-0.113	-0.406
20	-0.427	-0.535	-0.331	-0.255	-0.062	-0.331	-0.392	0.970
21	-0.017	0.022	0.153	-0.190	-0.181	0.183	-0.124	0.549
22	0.365	0.355	0.119	0.037	-0.275	0.391	0.573	-0.786
23	-0.316	-0.237	-0.224	-0.115	0.150	-0.532	0.162	-0.551
24	0.067	0.074	0.260	-0.131	0.069	0.106	-0.082	-0.073
25	-0.646	-0.723	-0.503	-0.158	0.132	-0.870	-0.131	0.314
26	0.752	0.706	0.459	0.156	-0.405	0.962	0.458	-0.296
27	-0.699	-0.934	-0.733	-0.538	0.213	-0.732	-0.644	0.736
28	0.045	0.114	0.060	0.228	0.361	-0.217	0.074	-0.770
29	-0.358	-0.437	-0.118	0.218	0.221	-0.672	-0.062	0.291
30	-0.421	-0.054	0.127	-0.075	-0.250	-0.326	0.244	0.178
31	-0.646	-0.544	-0.293	-0.323	-0.154	-0.543	-0.155	0.663

	17	18	19	20	21	22	23	24
17	1.000							
18	-0.201	1.000						
19	0.110	-0.263	1.000					
20	0.871	-0.217	-0.257	1.000				
21	0.866	0.248	-0.059	0.699	1.000			
22	-0.775	0.484	-0.064	-0.835	-0.532	1.000		
23	-0.358	-0.205	0.637	-0.520	-0.566	0.490	1.000	
24	0.455	0.101	0.122	0.109	0.549	0.114	0.058	1.000
25	0.283	-0.521	0.334	0.324	-0.129	-0.205	0.600	0.022
26	-0.292	0.856	-0.410	-0.315	0.222	0.457	-0.453	0.112
27	0.587	-0.402	-0.074	0.733	0.236	-0.560	0.007	0.112
28	-0.760	-0.311	0.419	-0.818	-0.894	0.558	0.747	-0.256
29	0.340	-0.588	0.298	0.328	-0.014	-0.243	0.462	0.158
30	0.669	-0.214	0.458	0.365	0.545	-0.306	0.175	0.484
31	0.864	-0.356	0.068	0.779	0.612	-0.563	-0.044	0.459

TRACE=31 * Variable numbers are the same with those in Table IV-11.

appreciable amount molecular species of chum salmon muscle lecithin*

9	10	11	12	13	14	15	16
1.000							
0.757	1.000						
-0.290	-0.539	1.000					
-0.168	0.050	-0.058	1.000				
-0.314	-0.583	0.982	-0.065	1.000			
0.609	0.796	-0.114	0.237	-0.120	1.000		
-0.321	-0.284	-0.289	-0.418	-0.312	-0.630	1.000	
-0.015	0.297	-0.485	-0.259	-0.527	-0.041	0.776	1.000
-0.302	-0.220	-0.272	-0.393	-0.294	-0.583	0.981	0.824
-0.215	-0.399	0.931	-0.039	0.847	-0.091	-0.214	-0.353
0.455	0.811	-0.375	-0.150	-0.413	0.519	-0.029	0.504
-0.326	-0.363	-0.293	-0.423	-0.317	-0.654	0.950	0.635
-0.458	-0.499	0.238	-0.423	0.220	-0.637	0.827	0.580
0.289	0.109	0.481	0.550	0.454	0.390	-0.824	-0.714
0.719	0.839	-0.387	0.356	-0.460	0.614	-0.433	0.011
-0.151	-0.147	0.112	0.341	0.112	-0.199	0.332	0.365
0.616	0.583	-0.742	-0.033	-0.816	0.110	0.309	0.452
-0.312	-0.580	0.986	-0.065	1.000	-0.120	-0.311	-0.524
-0.114	0.076	-0.603	0.130	-0.674	-0.223	0.664	0.646
0.530	0.701	-0.292	0.464	-0.266	0.776	-0.807	-0.369
0.693	0.496	-0.683	-0.178	-0.695	0.078	0.346	0.437
0.122	0.085	-0.289	-0.358	-0.312	-0.436	0.570	0.500
-0.097	-0.114	-0.481	-0.177	-0.520	-0.621	0.858	0.651
25	26	27	28	29	30	31	
1.000							
-0.810	1.000						
0.647	-0.668	1.000					
0.139	-0.269	-0.330	1.000				
0.905	-0.695	0.465	0.077	1.000			
0.413	-0.310	0.129	-0.302	0.505	1.000		
0.593	-0.517	0.676	-0.548	0.598	0.776	1.000	

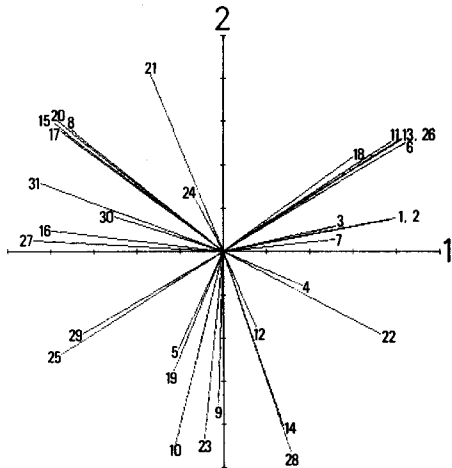

Fig. IV-56. Eigenvectors of the appreciable amount chum salmon muscle lecthin molecular species on the first and second principal component plane on PCA.

- | | |
|------------------------|-----------------------|
| 1. (16 : 2) (20 : 5), | 2. (20 : 5) (20 : 5) |
| 3. (20 : 5) (22 : 6), | 4. (22 : 6) (22 : 6) |
| 5. (20 : 4) (22 : 5), | 6. Unknown |
| 7. (20 : 3) (22 : 6), | 8. (20 : 5) (22 : 5) |
| 9. (20 : 4) (22 : 6), | 10. (22 : 5) (22 : 6) |
| 11. (22 : 4) (22 : 6), | 12. (16 : 1) (20 : 5) |
| 13. (22 : 6) (16 : 1), | 14. (16 : 1) (22 : 6) |
| 15. (14 : 0) (20 : 5), | 16. (14 : 0) (22 : 6) |
| 17. (17 : 0) (22 : 6), | 18. (20 : 5) (18 : 1) |
| 19. (18 : 1) (20 : 5), | 20. (22 : 6) (18 : 1) |
| 21. (18 : 1) (22 : 6), | 22. (20 : 5) (16 : 0) |
| 23. (16 : 0) (20 : 5), | 24. (22 : 6) (16 : 0) |
| 25. (16 : 0) (22 : 6), | 26. (22 : 5) (16 : 0) |
| 27. (16 : 0) (22 : 5), | 28. (16 : 0) (20 : 4) |
| 29. Unknown, | 30. (18 : 1) (16 : 0) |
| 31. (16 : 0) (18 : 1) | |

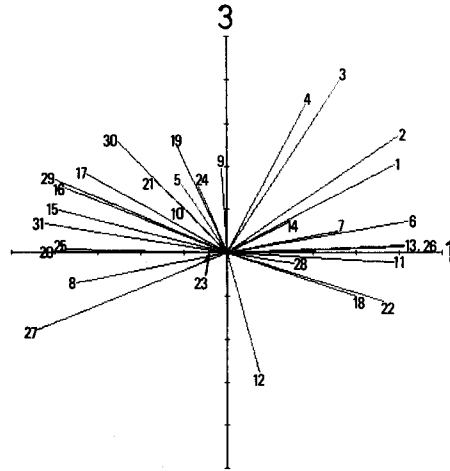

Fig. IV-57. Eigenvectors of the appreciable amount chum salmon muscle lecthin molecular species on the first and third principal component plane on PCA. Eigenvector numbers as in Fig. IV-56.

molecular species are 31 (see the footnote of Fig. IV-56). And number of samples correspond to the four different migratory stages of two different sexes (see the footnote of Table IV-15). "MEAN" in Table IV-11 is the average amount of each molecular species of the four stages and "S.D." is standard deviation. Correlations among all detected molecular species are shown in Table IV-12 and eigenvalues calculated by the Jacobi method from Table IV-12 are shown in Table IV-13. Values of contributions are also shown in this Table. Though variables were up to 31, the accumulated contribution was 63.7% when employed to the second principal component.

In Fig. IV-56, eigenvectors of appreciable amount molecular species are shown as small numbers on the first and second principal component plane. These are drawn up from the print out of component loading in columns 1 and 2 in Table

Table IV-13. Print out of eigenvalues as well as contributions of the appreciable amount molecular species of chum salmon muscle lecithin on PCA

COMPONENT	EIGENVALUE*	%**	ACC. %***
1	11.534	37.206	37.206
2	8.219	26.513	63.719
3	3.589	11.577	75.296
4	2.851	9.196	84.492
5	2.189	7.061	91.553
6	1.410	4.547	96.100
7	1.209	3.900	100.000
8	0.000	0.000	100.000
9	0.000	0.000	100.000
10	0.000	0.000	100.000
11	0.000	0.000	100.000
12	0.000	0.000	100.000
13	0.000	0.000	100.000
14	0.000	0.000	100.000
15	0.000	0.000	100.000
16	0.000	0.000	100.000
17	0.000	0.000	100.000

* Eigenvalue were calculated by the Jacobi method.

** % is the contribution.

*** ACC. % stands for accumulated contribution.

IV-14. And in Fig. IV-57, eigenvectors of the same molecular species are generated on the first and third principal component plane. And these are drawn up from the print out of component loading in columns 1 and 3 in Table IV-14 as well.

Principal loading in Table IV-15 was plotted on the first and second principal component plane as shown in Fig. IV-58 and on the first and third principal component plane as shown in Fig. IV-59. The movement according to the stage of migrations are shown by arrows. Very interesting movements are observed in this figure. By referring the eigenvectors in Fig. IV-56 at the same time, it can be observed that the movement direction from feeding migration stage to spawning migration stage (sea) is nearly parallel to the eigenvectors numbered 8, 15, 17, and 20 while it makes a right angle against eigenvectors 25 and 29. This shows that although the amounts of number 8 ((20 : 5) (22 : 5)), number 15 ((14 : 0) (20 : 5)), number 17 ((17 : 0) (22 : 6)) and number 20 ((22 : 6) (18 : 1)) are small as have seen in Fig. IV-51 and Fig. IV-52, drastic decrease of these molecular species occurs between these two stages, making good contrasts to number 25 ((16 : 0) (22 : 6)) and 29 (Unknown) which keep the constant amount. On the other hand, when the migratory stage proceeds to the spawning stage in the river, the movement of the arrow in this figure becomes almost parallel to the eigenvectors of number 25, 29 and also 6, 11, 13, 18 and 26. Number 25 is (16 : 0) (22 : 6) which is predominant, and

Table IV-14. Print out of component loading of the appreciable
 <COMPONENT LOADING>
 COMPONENT

	1	2	3	4	5	6	7	8
1	0.779	0.151	0.410	0.300	0.000	-0.044	0.331	0.000
2	0.797	0.157	0.544	0.022	-0.016	-0.085	-0.193	0.000
3	0.521	0.118	0.793	0.137	0.018	-0.243	-0.086	0.000
4	0.364	-0.154	0.691	0.276	-0.445	-0.268	0.139	0.000
5	-0.211	-0.453	0.315	0.735	0.304	-0.044	0.129	-0.000
6	0.842	0.503	0.145	0.070	0.040	-0.049	0.085	-0.000
7	0.517	0.058	0.099	-0.759	-0.371	-0.021	-0.068	0.000
8	-0.698	0.563	-0.141	0.176	-0.326	0.047	0.194	-0.000
9	-0.027	-0.712	0.388	-0.273	-0.283	0.147	0.406	-0.000
10	-0.223	-0.886	0.236	-0.022	0.121	0.306	0.027	0.000
11	0.774	0.511	-0.046	-0.160	0.152	0.228	0.192	-0.000
12	0.151	-0.345	-0.549	0.022	0.529	-0.518	0.088	-0.000
13	0.823	0.520	0.036	-0.064	0.107	0.114	0.151	-0.000
14	0.276	-0.808	0.133	0.292	0.208	0.282	0.215	0.000
15	-0.779	0.590	0.195	0.019	0.052	0.040	0.040	-0.000
16	-0.795	0.094	0.341	0.165	0.388	0.254	0.037	-0.000
17	-0.750	0.556	0.302	-0.040	0.185	0.034	-0.019	-0.000
18	0.599	0.440	-0.201	-0.331	0.225	0.428	0.254	0.000
19	-0.231	-0.550	0.494	-0.149	0.368	0.382	-0.312	0.000
20	-0.763	0.598	0.007	0.111	-0.166	0.046	0.131	-0.000
21	-0.333	0.817	0.339	-0.103	0.284	0.108	0.049	-0.000
22	0.723	-0.375	-0.223	-0.427	0.187	-0.154	0.214	0.000
23	-0.091	-0.866	0.001	-0.444	0.197	0.054	0.063	0.000
24	-0.132	0.247	0.305	-0.285	0.721	-0.422	0.225	-0.000
25	-0.751	-0.470	0.019	-0.315	-0.170	-0.001	0.294	-0.000
26	0.819	0.520	0.028	-0.073	0.112	0.125	0.155	-0.000
27	-0.881	0.051	-0.358	0.139	0.092	-0.019	0.255	0.001
28	0.309	-0.927	-0.052	0.038	0.032	-0.125	-0.157	0.000
29	-0.652	-0.378	0.367	-0.249	-0.249	-0.185	0.373	-0.000
30	-0.505	0.161	0.518	-0.607	0.097	-0.083	-0.256	0.000
31	-0.844	0.317	0.131	-0.348	0.049	-0.217	0.014	0.000

* The row and the column are variable numbers as same with those in Table IV-11.

the rest 6, 11, 13, 18 and 26 are small peaks. So it might be possible to conclude that (16:0)(22:6) is almost constant at the sea stage and becomes changeable at the stage of river.

Spent salmon showed an analogous position with that of spawning migration

amount molecular species of chum salmon muscle lecithin on PCA*

9	10	11	12	13	14	15	16	17
-0.000	-0.000	-0.000	-0.000	-0.000	0.000	0.000	0.000	0.000
0.000	0.000	-0.000	-0.000	0.000	0.000	0.000	0.000	0.000
0.000	-0.000	-0.000	-0.000	0.000	0.000	-0.000	0.000	-0.000
0.000	0.000	-0.000	0.000	0.000	0.000	-0.000	0.000	-0.000
-0.000	-0.000	-0.000	-0.000	0.000	0.000	0.000	0.000	-0.000
-0.000	-0.000	0.000	-0.000	-0.000	-0.000	0.000	-0.000	-0.000
0.000	0.000	0.000	0.000	-0.000	-0.000	-0.000	-0.000	0.000
-0.000	0.000	-0.000	0.000	0.000	0.000	-0.000	0.000	0.000
0.000	-0.000	-0.000	0.000	-0.000	-0.000	0.000	-0.000	-0.000
0.000	-0.000	0.000	-0.000	-0.000	-0.000	0.000	-0.000	0.000
-0.000	-0.000	0.000	0.000	-0.000	-0.000	0.000	-0.000	-0.000
-0.000	0.000	-0.000	-0.000	-0.000	-0.000	-0.000	0.000	-0.000
-0.000	-0.000	0.000	0.000	-0.000	-0.000	0.000	-0.000	-0.000
-0.000	0.001	0.000	-0.000	-0.000	0.000	0.000	-0.000	-0.000
-0.000	0.000	-0.000	0.000	0.000	0.000	-0.000	-0.000	-0.000
0.001	-0.000	0.000	-0.000	0.000	-0.000	0.000	-0.000	-0.000
-0.000	-0.000	-0.000	-0.000	0.000	-0.000	-0.000	-0.000	0.000
-0.000	-0.000	0.000	0.000	-0.000	-0.000	0.000	0.000	-0.000
-0.000	-0.000	0.000	-0.000	0.000	-0.000	-0.000	-0.000	0.000
-0.000	0.000	-0.000	0.000	0.000	0.000	-0.000	-0.000	-0.000
-0.000	0.000	-0.000	0.000	0.000	0.000	-0.000	-0.000	-0.000
0.000	-0.000	-0.000	-0.000	0.000	-0.000	-0.000	-0.000	0.000
0.000	-0.000	0.000	-0.000	-0.000	0.000	0.000	-0.000	-0.000
-0.000	0.000	-0.000	-0.000	-0.000	-0.000	-0.000	0.000	0.000
-0.000	-0.000	-0.000	0.000	-0.000	-0.000	-0.000	-0.000	-0.000
-0.000	-0.000	0.000	0.000	-0.000	-0.000	0.000	-0.000	-0.000
-0.000	-0.000	-0.000	0.000	-0.000	-0.000	-0.000	-0.000	-0.000
0.000	-0.000	0.000	0.000	-0.000	-0.000	0.000	0.000	0.000
-0.000	-0.000	0.001	0.000	-0.000	-0.000	-0.000	-0.000	0.000
0.000	0.000	-0.000	-0.000	-0.000	-0.000	-0.000	-0.000	0.000
-0.000	0.000	-0.000	-0.000	0.000	-0.000	0.000	0.000	0.000

stage in the sea on PCA planes as it is shown in Fig. IV-58 and Fig. IV-59. And from these two figures, it is clearly seen that the differences between male and female are considerably small compared with the differences among the migratory stages.

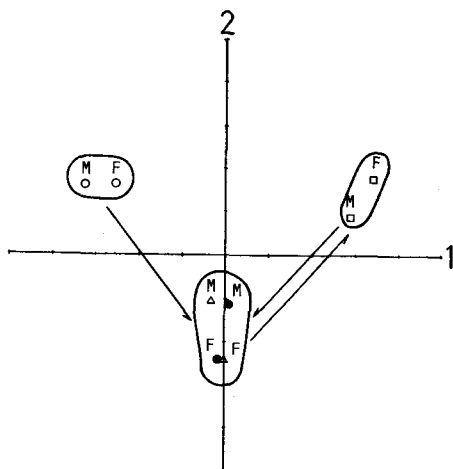

Fig. IV-58. Plots of principal loading on the first and second principal component plane on PCA.

Refer to the eigenvectors in Fig. IV-56 as background of this plane.

- M : Feeding migration, Male
- F : Feeding migration, Female
- M : Spawning migration, Male (Sea)
- F : Spawning migration, Female (Sea)
- M : Spawning migration, Male (River)
- F : Spawning migration, Female (River)
- △ M : Spent, Male
- △ F : Spent, Female

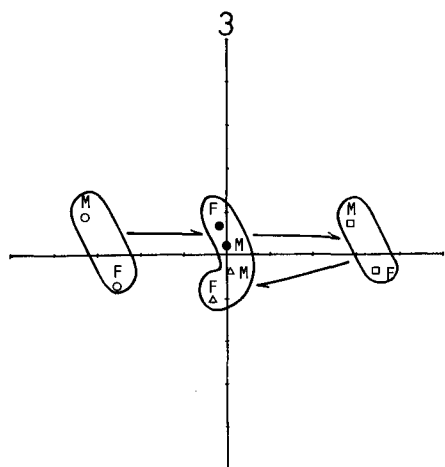

Fig. IV-59. Plots of principal loading on the first and third principal component plane on PCA.

Refer to the eigenvectors in Fig. IV-57 as background of this plane.

Symbols as in Fig. IV-58.

CHAPTER V

General Summary and Conclusions

Superiority of the reversed-phase type HPLC was emphasized.

In chapter I, it was suggested that dephosphorylation followed by acetylation is effective in separating the critical pairs of the lecithin molecular species on HPLC. The positional isomers were also separated to some extent unlike the triglycerides. And a new matrix model was proposed for the prediction of molecular species of lecithin. The matrix model was as follows :

Table IV-15. Print out of the principal loading (component score) of each stage of migration of chum salmon on PCA

〈PRINCIPAL LOADING〉

	PRINCIPAL					
	1	2	3	4	5	6
1	-16.352	8.027	4.458	-1.180	2.503	0.053
2	-12.737	8.015	-3.564	1.902	-3.121	0.148
3	0.044	-6.245	1.077	-5.306	-2.760	-0.548
4	-0.927	-12.116	3.177	1.654	0.248	0.991
5	14.315	4.307	3.658	3.165	-1.011	-1.825
6	17.100	8.946	-1.784	-2.333	1.217	1.493
7	0.368	-5.526	-1.912	2.337	0.221	1.715
8	-1.812	-5.408	-5.110	-0.239	2.702	-2.025

	7	8	9	10	11	12
1	-0.449	-0.000	0.000	-0.000	-0.000	-0.000
2	0.837	-0.000	0.000	-0.000	0.000	0.000
3	-0.606	0.000	0.000	0.000	-0.000	-0.000
4	1.841	0.000	-0.000	-0.000	0.000	0.000
5	-0.466	-0.000	-0.000	0.000	-0.000	-0.000
6	0.760	-0.000	-0.000	0.000	0.000	0.000
7	-2.172	0.000	-0.000	0.000	-0.000	0.000
8	0.255	0.000	0.000	0.000	0.000	-0.000

	13	14	15	16	17
1	0.000	-0.000	-0.000	-0.000	0.000
2	-0.000	-0.000	0.000	-0.000	0.000
3	0.000	0.000	0.000	0.000	-0.000
4	-0.000	0.000	-0.000	-0.000	0.000
5	-0.000	0.000	0.000	0.000	-0.000
6	0.000	-0.000	-0.000	0.000	0.000
7	-0.000	0.000	-0.000	-0.000	0.000
8	0.000	0.000	-0.000	0.000	-0.000

Row

- 1: Feeding migration, Male.
- 2: Feeding migration, Female.
- 3: Spawning migration, Male (Sea).
- 4: Spawning migration, Female (Sea).
- 5: Spawning migration, Male (River).
- 6: Spawning migration, Female (River).
- 7: Spent, Male.
- 8: Spent, Female.

$$\begin{aligned}
 CN &= P_1 \cdot \log(RRT) + q_1 & CN &= \begin{vmatrix} x & d_1 \\ c_2 & d_2 \end{vmatrix} \\
 DB &= P_2 \cdot \log(RRT) + q_2 & DB &= \begin{vmatrix} c_1 & y \\ c_2 & d_2 \end{vmatrix}
 \end{aligned}$$

where c_1 , c_2 and d_1 , d_2 are acyl carbon number and the number of double bonds in each acyl group line up in a similar way. x and y are variables of acyl carbon number and number of double bonds, respectively. P_1 and P_2 are the slopes and q_1 and q_2 are the intercepts (intersections) on the ordinate of the semilogarithmic plots of the RRTs of molecular species against CN or DB . RRT is the relative retention time (in general, it should be relative retention).

In chapter II, the matrix model proposed in chapter I was developed into the rules for molecular species of triglycerides. This idea was based on the expansion of matrix of (2, 2) type model for the lecithin molecular species to the matrix of (3, 2) type model for the triglyceride molecular species. The matrix model for the triglyceride was as follows:

$$\begin{aligned}
 CN &= P_1 \cdot \log(RRT) + q_1 & CN &= \begin{vmatrix} x & d_1 \\ c_2 & d_2 \\ c_3 & d_3 \end{vmatrix} \\
 DB &= P_2 \cdot \log(RRT) + q_2 & DB &= \begin{vmatrix} c_1 & y \\ c_2 & d_2 \\ c_3 & d_3 \end{vmatrix}
 \end{aligned}$$

where c_1 , c_2 , c_3 and d_1 , d_2 , d_3 are acyl carbon number and the number of double bonds in each acyl group line up in a similar way. x and y are variables of acyl carbon number and number of double bonds, respectively. P_1 and P_2 are the slopes and q_1 and q_2 are the intercepts (intersections) on the ordinate of the semilogarithmic plots of the RRTs of molecular species against CN or DB . RRT is the relative retention time. This matrix model was verified by the actual analysis of triglycerides from natural sources and from the chromatographic results presented by other investigators^{11,38,39}.

The theoretical background of the proposed new model was considered by introducing the theory of Martin⁴². He formulated the equation:

$$\frac{\Delta\mu_B}{R \cdot T} = \frac{\Delta\mu_A}{R \cdot T} + \frac{\Delta\mu_X}{R \cdot T}, \quad \ln \left(\frac{\alpha_B}{\alpha_A} \right) = \frac{\Delta\mu_X}{R \cdot T}$$

where A , B are members of a homologous series, differing by the functional group X , α is the partition coefficient and $\Delta\mu_X$ is the differences in chemical potential of the group X in polar or non-polar phase of the chromatographic system. It follows that each group in the solute molecule contributes more or less independently to the differences in standard free energy of the solute between the two different phases. Thus, in general, there is a linear relationship between $\ln \alpha$ or $\log \alpha$ and the number of functional groups in a homologous series. By substituting A in Martin's theory⁴²

as triglyceride species $\begin{vmatrix} c_1 & d_1 \\ c_2 & d_2 \\ c_3 & d_3 \end{vmatrix}$ and B as $\begin{vmatrix} c_1 + X & d_1 \\ c_2 & d_2 \\ c_3 & d_3 \end{vmatrix}$, X will become a functional

group. Or we could also substitute A as $\begin{vmatrix} c_1 & d_1 \\ c_2 & d_2 \\ c_3 & d_3 \end{vmatrix}$ and B as $\begin{vmatrix} c_1 & d_1 + Y \\ c_2 & d_2 \\ c_3 & d_3 \end{vmatrix}$, then Y will

also become a functional group. In this case, X corresponds to $-\text{CH}_2-$ unit and Y corresponds to $-\text{CH}=\text{CH}-$ unit. The chemical potential of the triglyceride molecule is principally affected by these X or Y , since in accordance with the elongation of the hydrocarbon chain or increase in the number of double bonds in the acyl group, the plots of RRT of each molecular species against CN or DB nearly draw an ascending or a descending straight line on semilogarithmic graph paper.

Thus the physicochemical background of the matrix model has been demonstrated from the theory of Martin⁴²⁾. A more detailed considerations were also done in this chapter II. Strictly speaking, in addition to the physicochemical functional groups, that is, $-\text{CH}_2-$ and $-\text{CH}=\text{CH}-$, the differences in arrangement of these units might slightly affect the total chemical potential of the triglyceride molecule (it was called Q factor). And from the view point of stereospecific structure, we should consider about the degree in bias between the α, β positional isomers. So the author has concluded that the chemical potential of the triglyceride molecule is the resultant of all functional groups in the molecule. The sum upped chemical

potential (μ) of triglyceride $\begin{vmatrix} c_1 & d_1 \\ c_2 & d_2 \\ c_3 & d_3 \end{vmatrix}$ was written as follows:

$$\mu = g \{f(c_1, d_1, Q_1), f(c_2, d_2, Q_2), f(c_3, d_3, Q_3)\}$$

where Q is an Q factor, f is the chemical potential given by the hydrocarbon chain, and g is the function of chemical potential given by the differences in α, β positional isomers. In order to give shape to this function, it was concluded that a more precised instruments (column, pump and detector of the HPLC) that gives a perfect reproductive data is required. Namely, for example, if the differences of RRT

between $\begin{vmatrix} c_1 & d_1 \\ c_2 & d_2 \\ c_3 & d_3 \end{vmatrix}$ and $\begin{vmatrix} c_2 & d_2 \\ c_1 & d_1 \\ c_3 & d_3 \end{vmatrix}$ can be measured perfectly, then the relation between $f(c_1, d_1, Q_1)$ and $f(c_2, d_2, Q_2)$ can be formularized by analyzing the multiple data. The $3\text{-}\mu\text{m}$ type column packing is expected for this purpose.

The theoretical relationship between the presented matrix model demonstrated in this study and the traditional ECN theory was also discussed in chapter II. It was proved mathematically that ECN is the degraded form of the presented matrix model.

In chapter III, the computer software for the identification of lecithin molecular species was designated.

The order of priority in the computer program for the identification of lecithin molecular species was as follows:

1. When there is a same molecular species in the data file, the RRT of this molecular species is printed out.

2. When there are molecular species that belong to the $\begin{vmatrix} x & d_1 \\ c_2 & d_2 \end{vmatrix}$ group (or

$\left| \begin{array}{cc} c_1 & d_1 \\ x & d_2 \end{array} \right|$), a regression line is generated and the RRT of the predicted molecular species is printed out.

3. When there are two parallel line groups that slightly differ in the slope due to the arrangement of $-\text{CH}_2-$ and $-\text{CH}=\text{CH}-$ units in the molecule, parallelogram is generated. And the RRT of the unknown vertex of this parallelogram is printed out.

4. When there are molecular species that belong to the $\left| \begin{array}{c} d_1 \\ d_2 \end{array} \right|$ group (when the combination of the acyl carbon number is unknown), the slope of the generalized regression line is introduced. And the RRT of the predicted species is printed out.

Though there is still a limitation for the perfect identification of all the molecular species contained in the samples from natural sources due to the incomplete reproducibility of RRT, this computer software might be convenient in predicting the generally found molecular species.

In chapter IV, from the view point of muscle lecithin molecular species, sardine, mackerel, big-eyed tuna, brown sole, sand flounder, rock fish, Alaska pollack, chum salmon, blue shark, mackerel shark, carp and rainbow trout were examined on HPLC. Among the fish examined, flat fish such as brown sole and sand flounder were extremely characteristic since these fish contained (16:0)(20:5) as the most prominent species unlike the rest of the fish that had (16:0)(22:6) as the most prominent species. Cartilaginous fish such as blue shark and mackerel shark had a very few amount of molecular species that have the combination of highly unsaturated fatty acids such as (20:5)(20:5), (20:5)(22:6) and (22:6)(22:6). This was also observed in fish from fresh water such as carp and rainbow trout. The main differences between the cartilaginous fish and the fresh water fish were in the contents of molecular species composed of 20:5 represented by (16:0)(20:5). These were rich in cartilaginous fish.

Principal component analysis (PCA) was done in order to characterize each fish in relation to all other fish examined. Except sardine dark muscle, chum salmon (feeding migration) and rainbow trout, a reflectable movement in the content of (20:5)(20:5) against seasonal variation was observed in the majority kind of fish examined.

Chum salmon of four different migratory stages were analyzed in the same manner. By introducing PCA again for the interpretation of muscle lecithin molecular species analysis among the migratory stages, interesting movement were observed on the first and second, as well as the first and third principal component plane in accordance with the advance in migration. The plots of male and female moved almost together on these planes. This implies that although there are some differences in molecular species between male and female especially at the stage of spawning migration in the river, these differences are not so large as the differences between the migratory stages. It was clearly seen that at the stage of spawning migration in the river, molecular species of (16:0)(22:6) drastically decreased.

The study of molecular species of fish lipid is at the dawn of a new age. Especially for the analysis of triglyceride molecular species, an effective high performance column that has a thorough theoretical plate to separate individual

molecular species is principally required. And a combination with the flame ionization detector (FID) or with the mass spectrometer is expected to back up a more precised determination. Attempt on the analysis using FID on HPLC has done by Privett *et al.*⁴⁹⁻⁵⁴⁾ And that on the analysis using mass spectrometer combined with HPLC has done by Kuksis *et al.*⁵⁵⁾ Matsushita *et al.*⁵⁶⁾ have used a mass spectrometer on the fractions obtained by HPLC manually. There is also an attempt done on a mass spectrometer without using HPLC for the fractionation⁵⁷⁻⁶³⁾ or by a high field ¹³C nuclear magnetic resonance spectrum (NMR) alone¹⁸⁾. But from the author's point of view, at least the HPLC fractionation might be inevitable prior to the mass spectrometer or NMR analysis. And these should be used only when it is necessary to analyze the overlapped peak on HPLC since the analytical cost using the mass spectrometer or NMR might be wasteful.

In this study, principal consideration for the complex lipid molecular species analysis was on lecithin. But the author is quite sure that the matrix model presented for the lecithin HPLC analysis well fits to the other complex lipid molecular species analysis as well. Nakagawa *et al.*^{64,65)} worked on the phosphatidylethanolamine molecular species of bovine brain and Un Hoi Do *et al.*¹⁷⁾, as well as Smith *et al.*¹³⁾ worked on the ceramides of bovine brain in addition to the studies on lecithin molecular species. In accordance with the data accumulation in this field, the invariability of the matrix model for all kinds of lipid molecular species is sure to be verified.

References

- 1) Takahashi, K., Zama, K. and Matsuoka, T. (1978). Molecular species of fish muscle lipids. I. Molecular species of triglyceride and phosphatidylcholine of sardine and rainbow trout. *Bull. Fac. Fish. Hokkaido Univ.* **29**, 378-385.
- 2) El-Hamdy, A.H. and Perkins, E.G. (1981). High performance reversed-phase chromatography of natural triglyceride mixtures. *J. Am. Oil Chem. Soc.* **58**, 49-53.
- 3) Hatano, H. (1981). "Saishin no Ekitai Kuromatogurafi". *J. Jap. Chem.* **35**, 283-292. (In Japanese).
- 4) Pauls, R.E. (1983). A time normalization study of the separation of olive oil triglycerides. *J. Am. Oil Chem. Soc.* **60**, 819-822.
- 5) Waters Associates Inc. LC seminar, held in Sapporo, Japan, in June 6th, 1980.
- 6) Wada, S., Koizumi, C. and Nonaka, J. (1977). Analysis of triglycerides of soybean oil by high-performance liquid chromatography in combination with gas liquid chromatography. *Yukagaku*. **26**, 95-99.
- 7) Wada, S., Koizumi, C., Takiguchi, A. and Nonaka, J. (1978). *Ibid.* **27**, 579-584.
- 8) Porter, N.A., Wolf, R.A. and Nixon, J.R. (1979). Separation and purification of lecithins by high pressure liquid chromatography. *Lipids*. **14**, 20-24.
- 9) Plattner, R.D., Spencer, G.F. and Kleiman, R. (1977). Triglyceride separation by reverse phase high performance liquid chromatography. *J. Am. Oil Chem. Soc.* **54**, 511-515.
- 10) Plattner, R.D. (1981). High performance liquid chromatography of triglycerides: Controlling selectivity with reverse phase columns. *Ibid.* **58**, 638-642.
- 11) El-Hamdy, A.H. and Perkins, E.G. (1981). High performance reversed phase chromatography of natural triglyceride mixtures: Critical pair separation. *Ibid.* **58**, 867-872.
- 12) Compton, B.J. and Purdy, W.C. (1982). High-performance liquid chromatography and detection of phospholipids and triglycerides. Part 1. Nonpolar stationary phase chromatographic behavior in ultraviolet transparent mobile phase. *Analytica Chim. Acta.* **141**, 405-410.
- 13) Smith, M., Monchamp, P. and Jungalwala, F.B. (1981). Separation of molecular species of

- sphingomyelin and ceramide by argentation and reversed-phase HPLC. *J. Lipid Res.* **22**, 714-719.
- 14) Hsieh, J. Y-K., Welch, D.K. and Turcotte, J.G. (1981). High pressure liquid chromatographic separation of molecular species of phosphatidic acid dimethyl esters derived from phosphatidylcholine. *Lipids*. **16**, 761-763.
 - 15) Porter, N.A., Wolf, R.A. and Weenen, H. (1980). The free radical oxidation of polyunsaturated lecithins. *Ibid.* **15**, 163-167.
 - 16) Crawford, C.G., Plattner, R.D., Sessa, D.J. and Rackis, J.J. (1980). Separation of oxidized and unoxidized molecular species of phosphatidylcholine by high pressure liquid chromatography. *Ibid.* **15**, 91-94.
 - 17) Un Hoi Do and Pei, P.T. (1981). Separation of molecular species of ceramides as benzoyl and *p*-nitrobenzoyl derivatives by high performance liquid chromatography. *Ibid.* **16**, 855-862.
 - 18) Hsieh, J. Y-K., Welch, D.K. and Turcotte, J.G. (1981). General method for the analysis of phosphatidylcholines by high-performance liquid chromatography. *J. Chromat.* **208**, 398-403.
 - 19) Smith, M. and Jungalwala, F.B. (1981). Reversed phase high performance liquid chromatography of phosphatidylcholine: A simple method for determining relative hydrophobic interaction of various molecular species. *J. Lipid Res.* **22**, 697-704.
 - 20) Patton, G.M., Fasulo, J.M. and Robins, S.J. (1982). Separation of phospholipids and individual molecular species of phospholipids by high-performance liquid chromatography. *Ibid.* **23**, 190-196.
 - 21) Ohshima, T., Wada, S. and Koizumi, C. (1983). Estimation of possible fatty acid combinations in phosphatidylcholine and phosphatidylethanolamine of cod. *Bull. Japan. Soc. Sci. Fish.* **49**, 123-130.
 - 22) Ohshima, T. and Koizumi, C. (1983). Accumulation of lysophosphatidylcholine and lysophosphatidylethanolamine in muscle of fresh skipjack. *Ibid.* **49**, 1205-1212. (In Japanese with English abstract).
 - 23) Ohshima, T., Wada, S. and Koizumi, C. (1983). Deterioration of phospholipids of skipjack muscle during ice storage: Mainly concerning to enzymatic hydrolysis of phosphatidylcholine. *Ibid.* **49**, 1213-1219. (In Japanese with English abstract).
 - 24) Ohshima, T., Wada, S. and Koizumi, C. (1983). Enzymatic hydrolysis of phospholipids in cod flesh during cold storage. *Ibid.* **49**, 1397-1404. (In Japanese with English abstract).
 - 25) Ohshima, T., Wada, S. and Koizumi, C. (1984). Enzymatic hydrolysis of phospholipids in cod flesh during storage in ice. *Ibid.* **50**, 107-114. (In Japanese with English abstract).
 - 26) Lands, W.E.M. and Hart, P. (1966). The control of fatty acid composition in glycerolipids. *J. Am. Oil Chem. Soc.* **43**, 290-295.
 - 27) Renkonen, O. (1965). Individual molecular species of different phospholipid classes. Part II. A Method of analysis. *Ibid.* **42**, 298-304.
 - 28) Privett, O.S. and Nutter, L.J. (1966). Determination of the structure of lecithins via the formation of acetylated 1, 2-diglyceride. *Lipids*. **2**, 149-154.
 - 29) Prevot, A.F. and Mordret, F.X. (1976). "Utilisation des colonnes capillaires de verre pour l'analyse des corps gras par chromatographie en phase gazeuse." *Rev. Fse Corps Gras*. **23**, 409-423. (In French).
 - 30) Funahashi, S., Hara, I. and Yamakawa, T. (1970). "Shishitsu 1." 531 p. Kyōritsu-Shuppan, Tokyo.
 - 31) Kosugi, H. and Ueda, N. (1976). "Hito Hishi no Bunseki-tokuni Toriguriserido no Kōzō." *Proc. J.C.B.L.* **18**, 9-12. (In Japanese).
 - 32) Zama, K., Maruyama, T. and Takahashi, K. (1976). Lipids of the Crustacea. I. Lipids of the muscle and the egg of the prawn (*Pandalopsis japonica*). *Bull. Fac. Fish. Hokkaido Univ.* **27**, 181-190. (In Japanese with English abstract).
 - 33) Takahashi, K., Cabling Jr, F. and Zama, K. (1978). Molecular species of fish muscle lecithin. II. Changes in triglyceride and phosphatidylcholine molecular species of sardine after frozen storage. *Ibid.* **29**, 386-391.
 - 34) Kuksis, A. (1972). Progress in the chemistry of fats and other lipids. **12**, 105-111, Pergamon Press, Oxford, New York, Tronto.
 - 35) Wood, R. and Snyder, F. (1969). Tumor lipids: metabolic relationships derived from structural analyses of acyl, alkyl, and alk-1-enyl moieties of neutral glycerides and phosphoglycerides.

- Arch. Biochem. Biophys.* **131**, 478-494.
- 36) Menzel, D.B. and Olcott, H.S. (1964). Positional distribution of fatty acids in fish and other animal lecithins. *Biochim. Biophys. Acta.* **84**, 133-139.
- 37) Wada, S. (1983). User's communications. *Jasco Report.* **18**, 18-20. (In Japanese).
- 38) Perkins, E.G., Hendren, D.J., Pelick, N. and Bauer, J.E. (1982). High performance reversed-phase chromatography of the triglycerides from human plasma lipoproteins. *Lipids.* **17**, 460-463.
- 39) Merritt, C., Vajdi, M., Kayser, S.G., Halliday, J.W. and Bazinet, M.L. (1982). Validation of computational method for triglyceride composition of fats and oils by liquid chromatography and mass spectrometry. *J. Am. Oil Chem. Soc.* **59**, 422-432.
- 40) Dong, M.W. and Dicesare, J.L. (1983). Improved separation of natural oil triglyceride by liquid chromatography using columns packed with 3- μ m particles. *Ibid.* **60**, 788-791.
- 41) Watari, M. and Kishi, M. (1982). *Personal computer library* **3**, 4-1-4-11. Kōgaku Tosho, Tokyo. (In Japanese).
- 42) Martin, A.J.P. (1950). Some theoretical aspects of partition chromatography. *Biochem. Soc. Symposia*, (Cambridge, England). **3**, 4-20.
- 43) Toya, Y., Umezawa, M., Takatori, T. and Hara, S. (1983). "Toriguriserido no HPLC Bunseki." Abstracts of the 22th annual meeting of Japan Oil Chem. Soc. 144 p. Osaka. (In Japanese).
- 44) Ishii, Z. (1980). "Iatorosukyan (Shinkurogurafu)." *Med. Technol.* **8**, 1196-1202. (In Japanese).
- 45) Crane, R.T., Goheen, S.C., Larkin, E.C. and Rao, G.A. (1983). Complexities in lipid quantitation using thin layer chromatography for separation and flame ionization for detection. *Lipids.* **18**, 74-80.
- 46) Kaitaranta, J.K. (1981). TLC-FID assessment of lipid oxidation as applied to fish lipids rich in triglycerides. *J. Am. Oil Chem. Soc.* **58**, 710-713.
- 47) Parrish, C.C. and Ackman, R.G. (1983). The effect of developing solvents on lipid class quantification in chromarod thin layer chromatography/Flame ionization detector. *Lipids.* **18**, 563-565.
- 48) Watari, M. and Kishi, M. (1982). *Personal computer library* **3**, 9-1-9-12, Kōgaku Tosho, Tokyo. (In Japanese).
- 49) Stolyhwo, A. and Privett, O.S. (1973). Studies on the analysis of lipid class by gradient elution adsorption chromatography. *J. Chromatogr. Sci.* **11**, 20-25.
- 50) Erdahl, W.L., Stolyhwo, A. and Privett, O.S. (1973). Analysis of soybean lecithin by thin layer and analytical liquid chromatography. *J. Am. Oil Chem. Soc.* **50**, 513-515.
- 51) Privett, O.S., Dougherty, K.A., Erdahl, W.L. and Stolyhwo, A. (1973). Studies on the lipid composition of developing soybeans. *Ibid.* **50**, 516-520.
- 52) Phillips, F.C., Erdahl, W.L. and Privett, O.S. (1982). Quantitative analysis of lipid classes by liquid chromatography via flame ionization detector. *Lipids.* **17**, 992-997.
- 53) Phillips, F.C. and Privett, O.S. (1981). Analysis of lipid classes and lipofuscin substances by high performance liquid chromatography. *J. Am. Oil Chem. Soc.* **58**, 590-594.
- 54) Phillips, F.C., Erdahl, W.L., Nadenicek, J.D., Nutter, L.J., Schmit, J.A. and Privett, O.S. (1984). Analysis of triglyceride species by high-performance liquid chromatography via flame ionization detector. *Lipids.* **19**, 142-150.
- 55) Kuksis, A., Marai, L. and Myher, J.J. (1984). Strategy of glycerolipid separation and quantitation by complementary analytical techniques. *J. Chromat.* **273**, 43-66.
- 56) Matsushita, S., Tada, Y., Kawamura, N., Ohnishi, E., Maeda, Y. and Ikushige, T. (1980). Rapid analysis of triglyceride of oils and fats by high speed liquid chromatography. "Tōyō Sōda Kenkyū Hōkoku." **24**, 29-33. (In Japanese).
- 57) Fukatsu, M., Watanabe, I. and Tamura, T. (1982). GC-MS analysis of triglyceride I. Total fatty acid composition. *Yukagaku.* **31**, 215-217. (In Japanese with English abstract).
- 58) Fukatsu, M., Tanaka, K. and Tamura, T. (1982). *Ditto*, II. The influence of low ionization voltage on fragment ion intensity. *Ibid.* **31**, 461-463. (In Japanese with English abstract).
- 59) Fukatsu, M. and Tamura, T. (1983). *Ditto*, III. Relationship between the fatty acid distribution and intensity ratios of specific fragment ions. *Ibid.* **32**, 92-95. (In Japanese with English abstract).
- 60) Fukatsu, M. and Tamura, T. (1984). *Ditto*, IV. Correction of fatty acid composition. *Ibid.*

- 33, 144-147. (In Japanese with English abstract).
- 61) Ahlberg, J., Curstedt, T., Einarsson, K. and Sjøvall, J. (1981). Molecular species of biliary phosphatidylcholines in gallstone patients: The influence of treatment with cholic acids and chenodeoxycholic acid. *J. Lipid Res.* **22**, 404-409.
 - 62) Kino, M., Matsumura, T., Gamo, M. and Saito, K. (1982). Studies on molecular species of choline and ethanolamine glycerophospholipids obtained from rat brain myelin and synaptosomes by gas-liquid chromatography mass spectrometry. *Biomed. Mass Spectrom.* **9**, 363-369.
 - 63) Crawford, C.G. and Plattner, R.D. (1983). Ammonia chemical ionization mass spectrometry of intact diacyl phosphatidylcholine. *J. Lipid Res.* **24**, 456-460.
 - 64) Nakagawa, Y. and Horrocks, L.A. (1983). "Kōsoku Ekitai Kuromatogurafī ni yoru Nō Etanōruamin Bunshishu no Bunseki oyobi Taisha e no Ōyō". *Proc. J.C.B.L.* **25**, 356-359. (In Japanese).
 - 65) Nakagawa, Y. and Horrocks, L.A. (1983). Separation of alkenylacyl, alkylacyl, and diacyl analogues and their molecular species by high performance liquid chromatography. *J. Lipid Res.* **24**, 1268-1275.