



HOKKAIDO UNIVERSITY

Title	COMPARATIVE MORPHOLOGY AND PHYLOGENY OF THE SUBORDER HEXAGRAMMOIDEI AND RELATED TAXA (PISCES: SCORPAENIFORMES)
Author(s)	SHINOHARA, Gento
Citation	MEMOIRS OF THE FACULTY OF FISHERIES HOKKAIDO UNIVERSITY, 41(1), 1-97
Issue Date	1994-03
Doc URL	https://hdl.handle.net/2115/21891
Type	departmental bulletin paper
File Information	41(1)_P1-97.pdf



COMPARATIVE MORPHOLOGY AND PHYLOGENY OF THE
SUBORDER HEXAGRAMMOIDEI AND RELATED
TAXA (PISCES : SCORPAENIFORMES)

By

Gento SHINOHARA

*Laboratory of Marine Zoology, Faculty of Fisheries,
Hokkaido University, Hakodate, Hokkaido 041, Japan*

Contents

	Page
I. Introduction	2
II. Acknowledgments	3
III. Materials and methods	3
IV. Systematic methodology	9
V. Comparative osteology	11
1. Circumorbital bones	11
2. Neurocranium	14
3. Jaws	19
4. Suspensorium and opercular bones	23
5. Hyoid arch	26
6. Branchial arches	30
7. Pectoral girdle	33
8. Pelvic girdle	37
9. Axial skeleton and median fin supports	38
10. Caudal skeleton	42
VI. Comparative myology	45
1. Cheek muscle	45
2. Cephalic muscles between neurocranium and suspensorium- opercular bones	47
3. Ventral muscles of head	48
4. Branchial muscles	49
5. Pectoral fin muscles	51
6. Pelvic fin muscles	53
7. Muscles associated with median fins	55
8. Caudal fin muscles	57
9. Body muscles	57
VII. Comparative cranial nervous system	59
1. Trigeminal nerves (V)	59
2. Facial nerves (VII)	61
VIII. External morphology	63

The present work was submitted as a partial fulfillment of the requirements for Doctor's degree in Fisheries Science at Hokkaido University in 1993.

IX.	Phylogenetic position of genera belonging to suborder "Hexagrammoidei" ..	65
	1. Relationships of scorpaeniform genera, including "hexagrammoids" ..	65
	2. Phylogenetic position of "hexagrammoid" genera ..	70
	3. Comparison with previous works ..	70
X.	Relationships of <i>Hexagrammos</i> species ..	70
	1. Character description and polarity in <i>Hexagrammos</i> species ..	72
	2. Interrelationships of <i>Hexagrammos</i> species ..	76
	3. Comparison with other works ..	77
XI.	General consideration ..	78
	1. Classification ..	78
	2. Zoogeography ..	80
	3. Phylogenetic evidence from other characters ..	83
XII.	Summary ..	86
XIII.	References ..	87
XIV.	Appendix ..	91

I. Introduction

The greenlings and related fishes, containing 12 species in five genera, are endemic to the coastal waters of the North Pacific Ocean. Most species live near or on the bottom, sometimes in seaweed, but some are active swimmers which move throughout the water column. Some of them are commercially important food species.

Since Regan (1913), the greenlings and others have been treated as a natural group (e.g., Berg, 1940; Rutenberg, 1962; Quast, 1965). Nelson (1984) included the group in the suborder Hexagrammoidei. However, the definition of this suborder is unclear and differs between workers (Lauder and Liem, 1983; Washington et al., 1984a). In addition, the relationships of the suborder "Hexagrammoidei" (*sensu* Nelson, 1984) are equally unclear. The suborder has been considered to be closely related to the anoplomatids by many authors (Jordan and Evermann, 1898; Regan, 1913; Berg, 1940; Lindberg, 1971; Nelson, 1976), who combined the two groups in the superfamily Hexagrammoidea. On the other hand, Quast (1965) and Gosline (1971) considered the "Hexagrammoidei" to be closely related to the cottids and related taxa.

Several proposals have been made regarding the classification within the "Hexagrammoidei". Although Regan (1913) and Berg (1940) included all of the "hexagrammoids" in the family Hexagrammidae, Jordan and Evermann (1898) had earlier recognized four families: the Hexagrammidae, Ophiodontidae, Oxylebiidae and Zaniolepididae. Schultz and DeLacy (1935-1936) recognized two families: the Hexagrammidae and Ophiodontidae. More recently, Quast (1965) proposed two families: the Hexagrammidae and Zaniolepididae.

The ongoing uncertainties in classification have clearly resulted from the lack of a sound phylogenetic basis for the suborder "Hexagrammoidei". Attention to this is clearly necessary.

The goals of this study are: (1) to describe the morphological characters of "hexagrammoids" and related taxa in detail; (2) to evaluate the potential mono-

phyly of the suborder "Hexagrammoidei"; and (3) to estimate their phylogeny and propose a cladistic classification on the basis of relationships.

II. Acknowledgments

I express my sincere thanks to Prof. Kunio Amaoka, Hokkaido University, for his guidance during this study and his critical reading of the manuscript. My special thanks go to Prof. Takashi Minoda and Assoc. Prof. Kazuhiro Nakaya, Hokkaido University, for their critical reading of the manuscript, and also to Dr. Stuart G. Poss, Senior Ichthyologist and Curator, Gulf Coast Research Laboratory Museum, for his advice and comments on the manuscript; Dr. Mamoru Yabe, Hokkaido University, for his valuable advice on fish phylogeny and cottoid morphology; and Dr. Graham S. Hardy, Ikeda City, Osaka, for his reading of the manuscript and comments.

I am deeply indebted to the following for their kind assistance, gifts and loan of materials, and for useful information: Drs. Alex E. Peden and Grant W. Hughes, British Columbia Provincial Museum; Drs. William N. Eschmeyer, Tomio Iwamoto and David Catania, California Academy of Sciences; Dr. Joseph S. Nelson, University of Alberta; Dr. Gregor M. Cailliet, Moss Landing Marine Laboratories; Drs. Osamu Okamura and Yoshihiko Machida, Kochi University; Dr. Theodore W. Pietsch, University of Washington; Dr. Ann C. Matarese, Alaska Fisheries Science Center; Dr. Tetsuji Nakabo, Kyoto University. I also express my thanks to Dr. Kaoru Kido, Ohma Town Office, Aomori; Dr. Tsutomu Kanayama, Sôgô Kagaku Incorporated, Osaka; Dr. Shigeru Shirai, Seikai National Fisheries Research Institute; Dr. Kiyonori Nishida, Osaka Aquarium Ring of Fire; Dr. Kunio Sasaki, Kochi University; Mr. Toru Miki, Himeji City Aquarium; Dr. Minoru Ishida, Nansei National Fisheries Research Institute; Mr. Kazuaki Naitoh, Hokkaido Fish Hatchery; Mr. Keiji Maeda, Hokkaido Fisheries Experimental Station; Mr. Masanobu Kai, Chita County Office, Aichi; Mr. Hisashi Imamura, Iai Girl's High School, Hokkaido; Mr. Hiromitsu Endo, Hokkaido University; and Mr. Tomoyuki Komai, Natural History Museum and Institute, Chiba, for their valuable advice and discussion. Finally, I am sincerely thankful to Messrs. Tomoki Shimokawa, Fumihito Mutoh, Kohichi Hoshino, Eiji Mihara, Keizoh Yoshimura, Tomoaki S. Gotoh, Christian O. Nyako, Naotaka Yoshimura, Daisuke A. Tsutsui and Hisayoshi Wakimoto, and Misses Miharu Nagamachi, Yukiko Gohda and Mika Okado for their supports and encouragement.

III. Materials and Methods

Materials examined in this study are listed below (abbreviations are given in Leviton et al., 1985).

Osteological and myological examinations were made on specimens stained in Alizarin Red-S; and Nikon SMZ-10 and Wild M-8 dissecting microscopes with a camera lucida were utilized in the preparation of drawings. Observations of the nervous system were made by dissection. Terminology generally follows Yabe (1985) for osteology, Winterbottom (1974) for myology, and Ray (1950) (partly

Freihofer, 1963 : e.g., RLA) for nervous system. Generic names follow Nelson (1984).

Materials.

Hexagrammoidei

Hexagrammidae

Hexagrammos octogrammus : 5 specimens, HUMZ 69065, 69948, 116279, 116280, 111729, 130.2-209.8 mm SL

Hexagrammos agrammus : 3 specimens, HUMZ 52895, 90804, 109982, 152.9-233.2 mm SL

Hexagrammos otakii : 4 specimens, HUMZ 48348, 69061, 65315, 101127, 196.7-220.5 mm SL

Hexagrammos stelleri : 4 specimens, HUMZ 75853, 80893, 84878, 86814, 175.0-233.3 mm SL

Hexagrammos decagrammus : 2 specimens, HUMZ 89407, 89408, 228.0-228.1 mm SL

Hexagrammos lagocephalus : 2 specimens, HUMZ 87843, 104878, 155.0-224.0 mm SL

Pleurogrammus azonus : 4 specimens, HUMZ 68476, 87648, 116270, 116275, 215.0-257.5 mm SL

Pleurogrammus monoptygius : 2 specimens, HUMZ 67483, 83991, 215.5-235.1 mm SL

Ophiodon elongatus : 3 specimens, HUMZ 7499, 7520, 46706, 375.0-466.3 mm SL

Zanioleptoidei

Zaniolepididae

Zaniolepis frenata : 1 specimen, HUMZ 111916, 149.0 mm SL

Zaniolepis latipinnis : 3 specimens, HUMZ 105077, 105286, 113067, 79.1-147.6 mm SL

Oxylebius pictus : 3 specimens, BCPM 974-485, 976-1303, HUMZ 113063, 105.1-178.4 mm SL

Anoplopomatoidei

Anoplopomatidae

Anoplopoma fimbria : 4 specimens, HUMZ 76489, 76775, 77017, 102810, 245.7-457.5 mm SL

Erilepis zonifer : 3 specimens, HUMZ 87882, 88050, 94021, 146.0-240.0 mm SL

Scorpaenoidei

Scorpaenidae

Apistus carinatus : 1 specimen, uncatalogued, 102.0 mm SL

Sebastes joyneri : 1 specimen, HUMZ 114344, 161.3 mm SL

Scorpaena izensis : 1 specimen, HUMZ 110754, 117.8 mm SL

Sebastes marmoratus : 1 specimen, HUMZ 69895, 124.0 mm SL

Sebastes tertius : 1 specimen, HUMZ 90233, 120.6 mm SL

Scorpaenodes kellogii : 1 specimen, HUMZ 111161, 73.4 mm SL

Setarches longimanus : 1 specimen, HUMZ 75392, 99.1 mm SL

Setarches fidjensis : 1 specimen, HUMZ 114391, 96.4 mm SL

Sebastobus macrochir : 1 specimen, HUMZ 87433, 126.6 mm SL

Scorpaenopsis diabolus : 1 specimen, uncatalogued, 121.4 mm SL

Pontinus macrocephalus : 1 specimen, HUMZ 74880, 130.5 mm SL

Dendrochirus zebra : 1 specimen, HUMZ 48699, 122.6 mm SL

Paracentropogon rubripinnis : 1 specimen, HUMZ 109269, 64.0 mm SL

Hozukius emblemarius : 1 specimen, HUMZ 35382, 175.0 mm SL

Helicolenus hilgendorfi : 1 specimen, HUMZ 79402, 127.0 mm SL

Synanceiidae

Inimicus japonicus : 1 specimen, HUMZ 52000, 146.6 mm SL

Minous monodactylus : 1 specimen, HUMZ 101863, 96.5 mm SL

Aploactinidae

Erisphex potti : 1 specimen, HUMZ 64275, 74.0 mm SL

Triglidae

Chelidonichthys spinosus : 1 specimen, HUMZ 65245, 193.5 mm SL

Peristediidae

Peristedion orientale : 1 specimen, HUMZ 106624, 151.8 mm SL

Platycephaloidei

Platycephalidae

Bembras japonica : 1 specimen, uncatalogued, 141.0 mm SL*Rogadius asper* : 1 specimen, uncatalogued, 161.6 mm SL*Suggrundus meerdervoorti* : 1 specimen, HUMZ 45288, 151.3 mm SL

Hoplichthyidae

Hoplichthys langsdorfi : 1 specimen, HUMZ 74809, 154.5 mm SL

Cottoidei

Cottidae

Blepsias cirrhus : 1 specimen, HUMZ 63525, 134.0 mm SL*Enophrys diceraus* : 1 specimen, uncatalogued, 122.4 mm SL*Hemilepidotus jordani* : 1 specimen, HUMZ 83088, 209.3 mm SL*Myoxocephalus polyacanthocephalus* : 1 specimen, HUMZ 68477, 225.0 mm SL*Triglops jordani* : 1 specimen, uncatalogued, 124.8 mm SL

Agonidae

Ocella iburia : 1 specimen, HUMZ 71463, 204.0 mm SL

Psychrolutidae

Dasycottus setiger : 1 specimen, HUMZ 83510, 157.5 mm SL*Malacocottus zonurus* : 1 specimen, HUMZ 83016, 142.5 mm SL

Cyclopteridae

Eumicrotremus birulai : 1 specimen, HUMZ 67949, 101.0 mm SL*Careproctus macrodiscus* : 2 specimens, HUMZ 55504, 78887, 175.0-220.0 mm SL*Liparis agassizii* : 1 specimen, HUMZ 80745, 150.0 mm SL

Berycoidei (Beryciformes)

Monocentridae

Monocentrus japonica : 2 specimens, HUMZ 33613, 49798, 120.0-136.0 mm SL

Diretmidae

Diretmus argenteus : 1 specimen, HUMZ 40224, ca. 55 mm SL

(previously dissected specimen)

Anoplogasteridae

Anoplogaster cornuta : 1 specimen, HUMZ 40410, 72.2 mm SL

Berycidae

Beryx splendens : 1 specimen, HUMZ 79840, 121.9 mm SL

Holocentridae

Ostichthys japonicus : 1 specimen, HUMZ 49795, 200.6 mm SL

(previously dissected specimen)

Trachichthyidae

Hoplostethus japonicus : 1 specimen, HUMZ 51824, 102.5 mm SL

Percoidae (Perciformes)

Kuhliidae

Kuhlia mugil : 1 specimen, HUMZ 48505, 89.4 mm SL

Serranidae

Epinephelus moara : 1 specimen, HUMZ 110189, 145.5 mm SL*Plectranthias japonicus* : 1 specimen, HUMZ 39002, 100.0 mm SL

Teraponidae

Terapon jarbua : 1 specimen, HUMZ 79350, 91.9 mm SL

Pempheidae

Pemppheris xanthoptera : 1 specimen, HUMZ 41462, 114.8 mm SL

Percichthyidae

Acropoma japonicum : 1 specimen, HUMZ 79966, 121.8 mm SL*Doederleinia berycoides* : 1 specimen, HUMZ 79421, 129.6 mm SL*Lateolabrax japonicus* : 1 specimen, HUMZ 42257, 213.0 mm SL

- Malakichthys wakiyae* : 1 specimen, HUMZ 79412, 137.2 mm SL
Nippon spinosus : 2 specimens, uncatalogued, HUMZ 47416, 130.0-171.0 mm SL
Stereolepis gigas : 1 specimen, HUMZ 78521, 138.3 mm SL
Synagrops japonicus : 2 specimens, HUMZ 79446, 79966, 121.8-131.7 mm SL
- Percidae
Perca flavescens : 1 specimen, HUMZ 17389, 106.2 mm SL
- Cirrhitidae
Cirrhitichthys aureus : 1 specimen, uncatalogued, 75.0 mm SL
Paracirrhites forsteri : 1 specimen, HUMZ 44348, 90.0 mm SL
- Mullidae
Upeneus bensasi : 1 specimen, HUMZ 110428, 107.4 mm SL
- Haemulidae
Haplogenyx macronotus : 1 specimen, HUMZ 108350, 128.3 mm SL

Anatomical abbreviations.

The following abbreviations are used in the figures.

Bone and Cartilage

acp : ascending process	act : actinost
alp : alveolar process	ang : anguloarticular
arp : articular process	bb : basibranchial
bh : basihyal	bo : basioccipital
br : branchiostegal ray	bs : basisphenoid
cb : ceratobranchial	ch : ceratohyal
cle : cleithrum	com : coronomeckelian
cor : coracoid	den : dentary
der : dermosphenotic	dhh : dorsal hypohyal
dp : distal pterygiophore	dpc : dorsal posteleithrum
ecp : ectopterygoid	eb : epibranchial
eh : epihyal	enp : entopterygoid
eo : exoccipital	ep : epiotic
epr : epipleural rib	eth : ethmoid
eu : epural	fro : frontal
hb : hypobranchial	hh : hypohyal
hs : haemal spine	hyo : hyomandibular
hyp : hypural	iac : interarcual cartilage
ic : intercalar	ih : interhyal
io : infraorbital	iop : interopercle
lac : lachrymal	let : lateral ethmoid
max : maxillary	mec : Meckelian cartilage
mep : metapterygoid	ns : neural spine
op : opercle	p : pterygiophore
pa : parietal	pal : palatine
pb : pharyngobranchial	pd : predorsal
phy : parhypural	pmp : postmaxillary process
pop : preopercle	pp : proximal pterygiophore
ppp : postpelvic process	pr : pleural rib
prm : premaxillary	pro : prootic

ps : parasphenoid	pt : posttemporal
pto : pterotic	pts : pterosphenoid
pu : preural centrum	pv : prevomer
qua : quadrate	rc : rostral cartilage
ret : retroarticular	sbk : subpelvic keel
sbp : subpelvic process	sca : scapula
scl : supracleithrum	so : supraoccipital
sop : subopercle	spk : suprapelvic keel
spo : sphenotic	st : supratemporal
sym : symplectic	un : uroneural
us : urostyle	vhh : ventral hypohyal
vpc : ventral postcleithrum	

Muscle

A1-3 & Aw : adductor mandibulae sections 1-3 and w
aap : adductor arcus palatini
abp : abductor profundus
abpp : abductor profundus pelvici
abs : abductor superficialis
absp : abductor superficialis pelvici
adp : adductor profundus
adpp : adductor profundus pelvici
ads : adductor superficialis
absp : adductor superficialis pelvici
ard : arrector dorsalis
ardp : arrector dorsalis pelvici
arv : arrector ventralis
arvp : arrector ventralis pelvici
co : coracoradialis
dea : depressores anales
ded : depressores dorsales
do : dilatator operculi
epax : epaxialis
era : erectores anales
erd : erectores dorsales
exp : extensor proprius
fd : flexor dorsalis
fds : flexor dorsalis superior
fv : flexor ventralis
fve : flexor ventralis externus
fvi : flexor ventralis inferior
hab1-2 : hyohyoidei abductores sections 1-2
had : hyohyoidei adductores
hpax : hypaxialis
hl : hypochordal longitudinalis
ina : inclinatores anales
ind : inclinatores dorsales

ifcp : infracarinalis posterior
 im : intermandibularis
 int : interradians
 lap : levator operculi
 lee : levator externus
 lei : levator internus
 lep : levator posterior
 lo : levator operculi
 lpe : levator pectoralis
 obd : obliquus dorsalis
 obi : obliquus inferioris
 obp : obliquus posterior
 obs : obliquus superioris
 obv : obliquus ventralis
 pce : pharyngoclavicularis externus
 pci : pharyngoclavicularis internus
 ph : protractor hyoidei
 pp : protractor pectoralis
 rc : rectus communis
 rd : retractor dorsalis
 rv : rectus ventralis
 sbm : swimbladder muscle
 so : sphincter oesophagi
 spca : supracarinalis anterior
 spcp : supracarinalis posterior
 sth : sternohyoideus
 tda : transversus dorsalis anterior
 tdp : transversus dorsalis posterior
 tva : transversus ventralis anterior
 tvp : transversus ventralis posterior

Ligament and Tendon

bl : Baudelot's ligament
 lp : ligamentum primordium
 l-ri : retroarticulo-interopercular ligament
 l-em : ethmo-maxillary ligament
 l-pp : palato-premaxillary ligament
 l-mp : maxillo-premaxillary ligament
 tA2-3 : tendons of adductor mandibulae sections 2-3

Nerve

hVII : ramus hyoideus
 mnV : ramus mandibularis trigeminus
 mnV-e : ramulus mandibularis externus trigeminus
 mnV-i : ramulus mandibularis internus trigeminus
 mnV-c : ramulus mandibularis cutaneous trigeminus
 mnVII : ramus mandibularis facialis
 mnVII-e : ramulus mandibularis externus facialis

mnVII-i	: ramulus mandibularis internus facialis
mxV	: ramus maxillaris trigeminus
mxV-i	: ramulus maxillaris inferioris trigeminus
mxV-s	: ramulus maxillaris superioris trigeminus
ophVII	: ramus ophthalmicus superficialis facialis
ophV	: ramus ophthalmicus superficialis trigeminus
oVII	: ramus oticus
opVII	: ramus opercularis facialis
pVII	: ramus palatinus facialis
RLA	: ramus lateralis accessorius
RLA-OP	: orbito-pectoral branch of RLA
RLA-PD	: parieto-dorsal branch of RLA to dorsal fin
RLA-PP	: pectoral branch of RLA arising from RLA-PD

IV. Systematic methodology

In this study, the cladistic methodology formulated by Hennig (1966) is adopted for estimating the phylogenetic relationships of the "Hexagrammoidei" and related taxa. The monophyly of the "hexagrammoids" in the order Scorpaeniformes is evaluated. Although the monophyly of the Scorpaeniformes, which must be defined by some synapomorphies before an analysis can begin, has been questioned (Quast, 1965; Greenwood et al., 1966; Eschmeyer, 1969), it is considered as a monophyletic group in this study, on the basis of its definition by the combination of the following characters: (1) suborbital stay, (2) parietal supporting a sensory canal and (3) presence of a swimbladder muscle. The presence of a suborbital stay has been accepted as a diagnostic character for the order by many authors over many years (e.g., Regan, 1913; Matsubara, 1955). The parietal supporting a sensory canal and presence of a swimbladder muscle, not previously established as diagnostic characters, are thought to be apomorphic because in the superorder Acanthopterygii the former character is found only in some percoids, *Perca* and *Nippon* (pers. obs.), and some zoarcoids (Makushok, 1958; Anderson, 1982; Yatsu, 1986), and the latter only in some percoids (Hazlett and Winn, 1962; Vari, 1978; Sasaki, 1989). Although a parietal structure, supporting a sensory canal, is absent in the Cyclopteridae (Ueno, 1973; Kido, 1988), this condition can be considered to have been secondarily lost because of the advance of the epaxial muscle in this region. Since the order Scorpaeniformes can, therefore, be considered as a monophyletic group, it thus provides a basis for a phylogenetic consideration of the "Hexagrammoidei".

The two following steps were adopted for estimating the phylogeny of the "Hexagrammoidei": (1) reconstruction of relationships between "hexagrammoid" and other scorpaeniform genera, and (2) inference of interrelationships among *Hexagrammos* species.

(1) Reconstruction of relationships between "hexagrammoid" and other scorpaeniform genera

Morphological characters such as osteological and myological features, nerve characteristics and external features were surveyed in the "Hexagrammoidei" and other scorpaeniforms, with those showing generic variation being selected and

prepared for analysis.

Outgroup comparison (e.g., Crisci and Stuessy, 1980 ; Watrous and Wheeler, 1981 ; Wiley, 1981) was adopted for the determination of polarity. However, the closest relatives of the Scorpaeniformes have been not elucidated to date (Greenwood et al., 1966 ; Lauder and Liem, 1983). Owing to the presence of spines in the dorsal, anal and pelvic fins, the Scorpaeniformes is included in the superorder Acanthopterygii of Patterson (1964) and Greenwood et al. (1966). Because some members of the former have retained many generalized acanthopterygian features, the precursor of the order is believed to be near the ancestor of Acanthopterygii (Gill, 1889 ; Greenwood et al., 1966). Since it is suspected that the Scorpaeniformes was derived from a basal acanthopterygian, character polarities are determined by comparison with those of basal acanthopterygians as an outgroup. In this study, character conditions most frequently and constantly found in the berycoids and percoids, which are regarded as primitive acanthopterygians (e.g., Lauder and Liem, 1983), are hypothesized as representing the basal acanthopterygian conditions.

(2) Inference of interrelationships among *Hexagrammos* species

Morphological and meristic characters were examined in the genus *Hexagrammos*. For the selection of meristic characters, the range gap-coding method, which is newly established here, was adopted (see below). Characters varying within

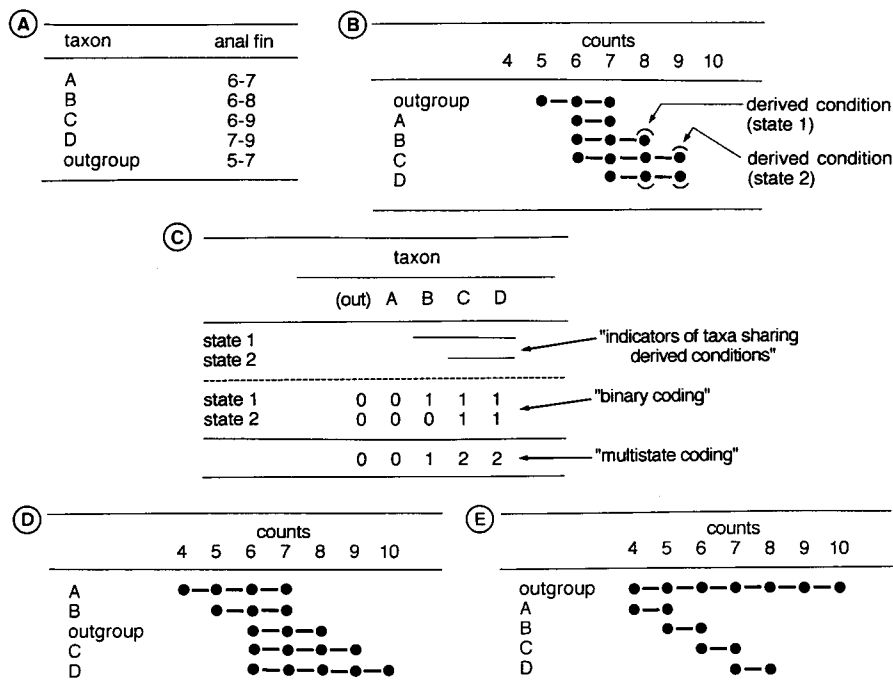

Fig. 1. Example for explanation of range gap-coding method. A, ranges of anal fin ray counts among taxa A-D and outgroup ; B, comparison of ranges in A ; C, coding procedure ; D and E, cases differing from above.

species were omitted. Character polarity in a defined monophyletic group was determined by outgroup comparison (Maddison et al., 1984).

Range Gap-Coding Method

In order to use overlapping meristic counts as characters, several coding methods such as generalized gap-coding and subset gap-coding, have been established (e.g., Archie, 1985; Goldman, 1988). However, means and standard deviations are necessary in order to utilize such methods. The range gap-coding method proposed here requires only the range of meristic counts, which is useful when the mean and/or standard deviation are unknown. The method is explained below, using examples of anal fin counts of imaginary taxa A-D and their outgroup (Fig. 1A). Taxa A-D are arranged according to the similarity of their counts, taxon A, which has the number closest to the outgroup is arranged near the outgroup, being placed near the latter. Taxon D, which differs the most, is located farthest from the outgroup (Fig. 1B). Counts overlapping those of the outgroup are regarded as the primitive state. Therefore, three taxa (B-D) share a derived condition, having eight (more than seven) anal fin rays (state 1). Moreover, two taxa (C & D) have a further derived condition, having nine (more than eight) anal fin rays (state 2). These results can be expressed in a table (Fig. 1C), taxa with state 1 being coded as "1" (derived) and the others as "0" (primitive), according to binary character coding. State 2 is also coded as "1" for derived and "0" for primitive conditions. Subsequently, multistate character coding can be made by addition of the two binary codes. When the meristic range of the outgroup is located within those of the objective taxa (Fig. 1D), two separate character assessments are made, one related to the increase in numbers and the other to the decrease. When the meristic range of the outgroup includes all of the counts in the objective taxa, polarity can not be determined by outgroup comparison (Fig. 1E). Consequently, the method is inadequate in this case.

The cladogram was constructed on the basis of Fitch parsimony (Wiley et al., 1991). The minimum tree was calculated by using the computer program, PAUP (Phylogenetic Analysis Using Parsimony) version 3.0s (Swofford, 1991) with a heuristic method for estimating interrelationships of scorpaeniform genera, plus an exhaustive search for those of *Hexagrammos* species.

V. Comparative osteology

1. Circumorbital bones (Figs. 2-4)

Description. The circumorbital bones comprise a lachrymal and (usually) five infraorbitals (four in *Zaniolepis*), and are associated with part of the lateral line system (= infraorbital canal).

The lachrymal is a large triangular bone, dorsally bearing an articulating facet for the lateral ethmoid (Fig. 3C). An inner projection for articulation with the palatine (Fig. 3B, C) provides a firm attachment with the latter (= lachryopalatine articulation). The ventral margin is smooth, covering the anterior part of the maxillary.

The first infraorbital, a rectangular bone, firmly connected with the lachrymal and second infraorbital, lacks a suborbital shelf. It is plate-like, bearing primary

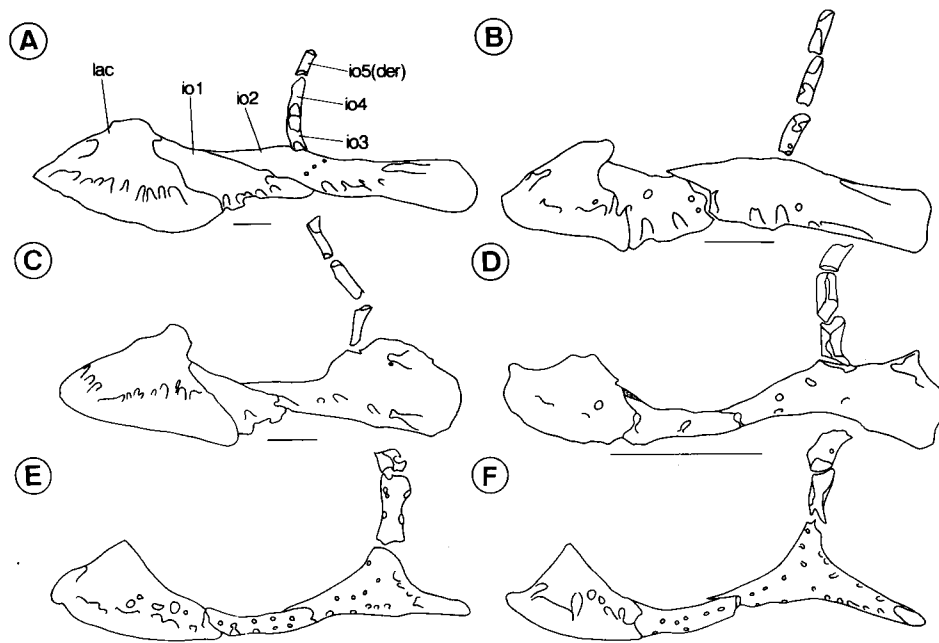

Fig. 2. Lateral aspect of circumorbital bones. A, *Ophiodon elongatus*; B, *Hexagrammos decagrammus*; C, *Pleurogrammus azonus*; D, *Oxylebius pictus*; E, *Zanivolepis frenata*; F, *Z. latipinnis*. Bars=5 mm.

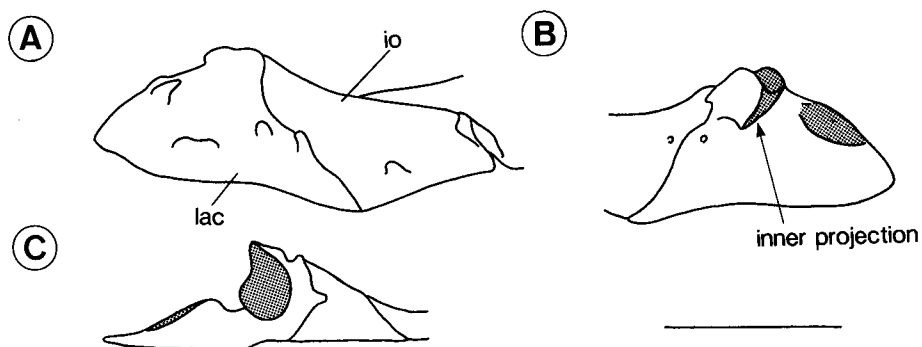

Fig. 3. Anterior circumorbital bones of *Hexagrammos agrammus*. A, lateral view; B, medial view; C, dorsal view. Bar=5 mm.

tubules in *Hexagrammos*, *Pleurogrammus* and *Ophiodon* (Fig. 4), but is tube-like in other genera.

The second infraorbital is large and elongate, with some adductor mandibulae muscle fibers inserted onto its medial face. A suborbital shelf is absent. Its posterior attachment to the preopercle forms a suborbital stay, the posterior margin

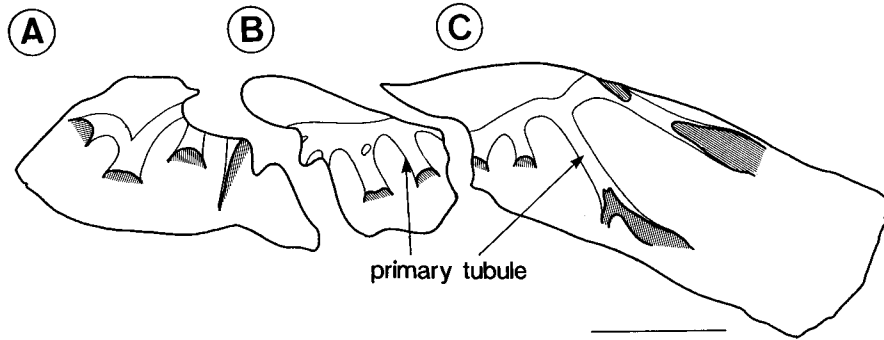

Fig. 4. Lateral aspect of circumorbital bones in *Hexagrammos lagocephalus*. A, lachrymal; B, first infraorbital; C, second infraorbital. Bar=5 mm.

of which is truncated. Two or more well-developed primary tubules are present on the second infraorbital in *Hexagrammos*, *Pleurogrammus* and *Ophiodon*.

The remaining infraorbitals are tiny and tube-like. The last infraorbital (=dermosphenotic) is firmly attached to the sphenotic in *Oxylebius* and *Zaniolepis*.

Character argumentation. Seven circumorbital bone characters were recognized and polarized (Characters 1-7). The basal acanthopterygian conditions are shown in the Appendix.

I. Apomorphic characters found in "Hexagrammoidei"

Character 1. Presence of primary tubules on first infraorbital

Among the "Hexagrammoidei" this condition was found only in *Hexagrammos*, *Pleurogrammus* and *Ophiodon*. The common basal acanthopterygian condition is the absence of primary tubules. Therefore, their presence represents a derived condition, which was not observed in the other Scorpaeniformes.

Character 2. Dermosphenotic loosely attached to sphenotic

This condition was found in *Hexagrammos*, *Pleurogrammus* and *Ophiodon*. In basal acanthopterygians, the last infraorbital (=dermosphenotic) is firmly attached or fused to the sphenotic. Therefore, a loose attachment is apomorphic in the Scorpaeniformes. Although Quast (1965) suggested this apomorphic condition to be present in *Oxylebius*, such was not confirmed by this study. The apomorphic condition was also found in all cottoids examined.

Character 3. Absence of suborbital shelf

The suborbital shelf was absent in every "hexagrammoid", but found in some scorpaenids: viz. *Scorpaenodes*, *Sebastes*, *Sebastiscus*, *Hozukius*, *Helicolenus* and *Paracentropogon*. The general basal acanthopterygian condition is presence of a suborbital shelf. Its occurrence in the Scorpaenidae is thought to be an evidence of their basal organization, such as vertebral number=10+14 and the bass-like body, and is considered primitive in that family.

Character 4. Presence of lachryopalatine articulation

This condition was found in all "Hexagrammoidei", but is generally absent in basal acanthopterygians. Therefore, the presence of a lachryopalatine articulation is considered apomorphic in the Scorpaeniformes. Of the other Scorpaeniformes

examined, all cottoids possessed the articulation, confirming Yabe's (1985) observation.

II. Apomorphic characters absent in "Hexagrammoidei", but present in other Scorpaeniformes

Character 5. Presence of lachrymal spines on ventral margin

One platycephaloid, *Bembras* and many of the scorpaenoids examined here possessed lachrymal spines, whereas basal acanthopterygians generally have a lachrymal with a smooth ventral margin. The presence of spines is considered apomorphic, the condition already having been reported in the scorpaenoids and platycephaloids by, for example, Matsubara (1943a) and Matsubara and Ochiai (1955).

Character 6. Second infraorbital attached to lateral ethmoid

A "transformed" second infraorbital bone, being attached to the lateral ethmoid as described in *Pterygotrigla* (Triglidae) by Regan (1913 : Fig. 1), was observed only in *Chelidonichthys* (Triglidae) and *Peristedion* (Peristediidae). The condition is considered apomorphic owing to its absence in basal acanthopterygians. Quast (1965) used the character to separate his Hexagrammidae from the Triglidae (including Peristediidae of this study).

Character 7. Lachrymal with anteriorly projecting spine

An anteriorly projecting lachrymal spine was observed in *Chelidonichthys* and *Peristedion*. The condition is considered apomorphic owing to its absence in basal acanthopterygians.

III. Other characters

Decrease of number of infraorbitals

The total number of infraorbitals in *Zaniolepis* is four. This condition may be more derived than that of other "Hexagrammoidei" (number=5) because the basal acanthopterygian number was usually five or more (Smith and Bailey, 1962 ; pers. obs.). Reduction of the infraorbital number in *Zaniolepis* appears to have resulted from a fusion of the third and fourth elements. Although in the other scorpaeniforms, a reduction in infraorbital number has occurred in several taxa (Matsubara, 1943a ; Matsubara and Ochiai, 1955 ; Yabe, 1985 ; Kanayama, 1991 ; pers. obs.), the identity of the fused and/or lost elements can not be determined. Because homology between other taxa and *Zaniolepis* is questionable, the character was not used in the analysis.

2. Neurocranium (Figs. 5-8)

Description. The neurocranium, including the nasal, comprises seventeen bones, of which eleven are paired and six unpaired. Paired bones include the nasal, lateral ethmoid, frontal, parietal, pterosphenoid, sphenotic, prootic, pterotic, epiotic, intercalar and exoccipital. Unpaired bones include the prevomer, ethmoid, supraoccipital, basioccipital, basisphenoid and parasphenoid.

The nasal is a flat bone, connected with the frontal and lateral ethmoid posteriorly, and bearing a supraorbital sensory canal continuing from the frontal (Fig. 5). A spine, directed posterodorsally, is present on the posterior region in *Oxylebius*, *Zaniolepis* and one species of *Hexagrammos* (= *H. decagrammus*).

The prevomer is toothed, occupying the anteroventral portion of the cranium,

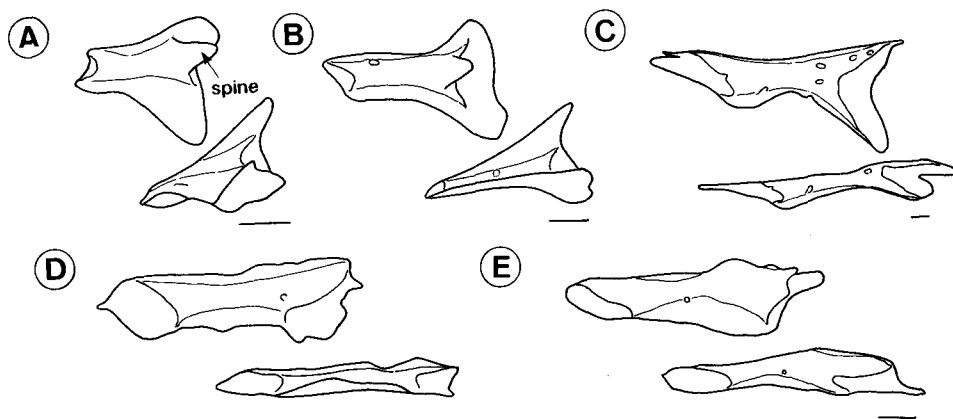

Fig. 5. Dorsal (above) and lateral (below) aspects of nasal. A, *Oxylebius pictus*; B, *Zaniolepis frenata*; C, *Ophiodon elongatus*; D, *Pleurogrammus azonus*; E, *Hexagrammos otakii*. Bars = 1 mm.

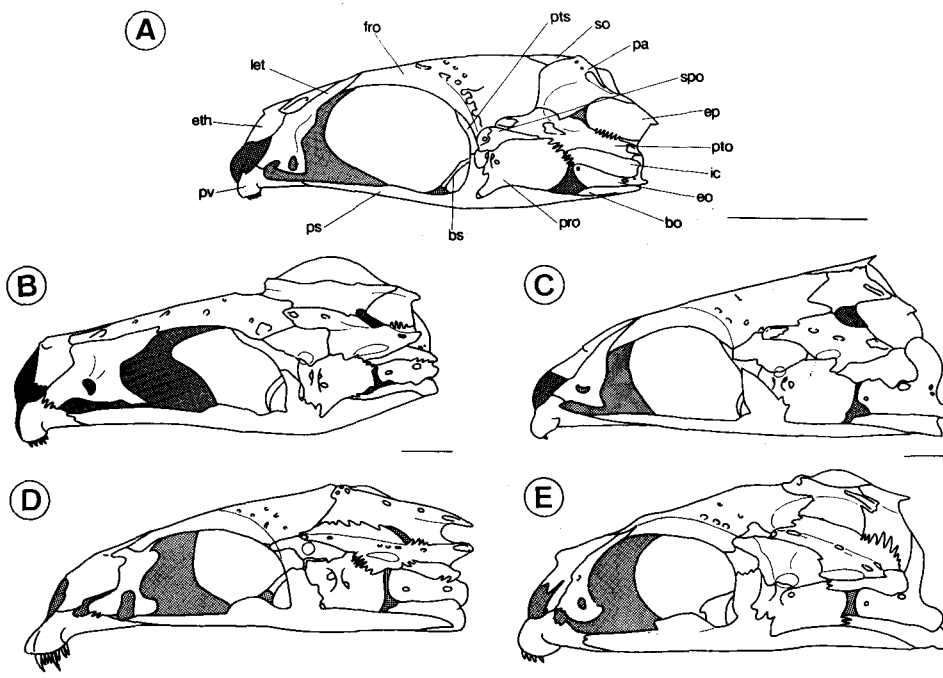

Fig. 6. Lateral aspect of neurocranium. A, *Zaniolepis latipinnis*; B, *Pleurogrammus azonus*; C, *Oxylebius pictus*; D, *Ophiodon elongatus*; E, *Hexagrammos octogrammus*. Bars = 5 mm.

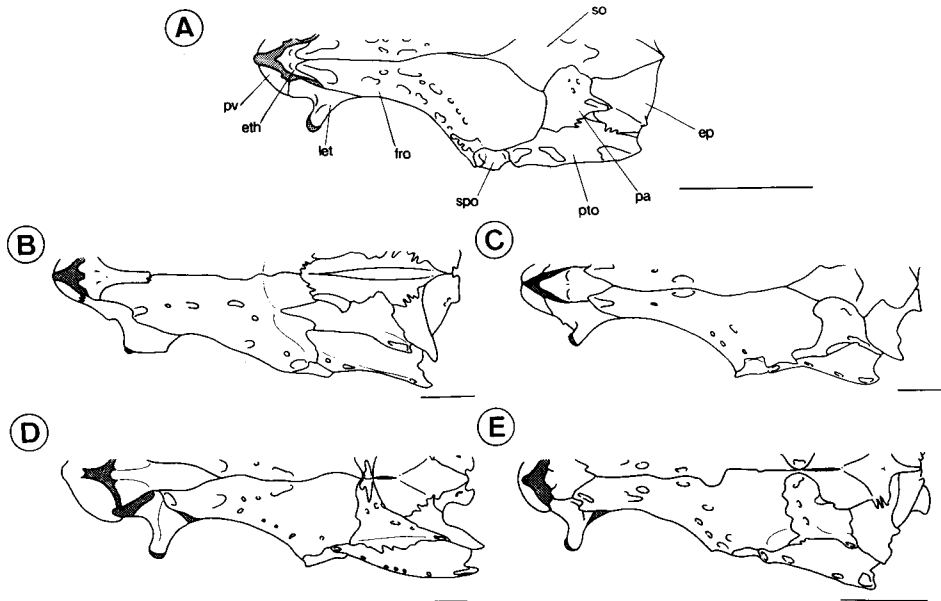

Fig. 7. Dorsal aspect of neurocranium. A, *Zaniolepis latipinnis*; B, *Pleurogrammus azonus*; C, *Oxylebius pictus*; D, *Ophiodon elongatus*; E, *Hexagrammos octogrammus*. Bars = 5 mm.

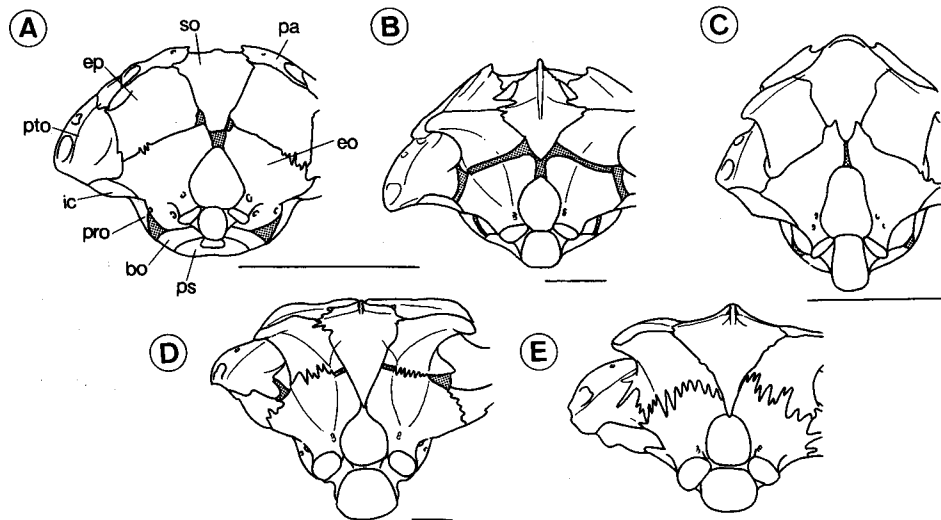

Fig. 8. Posterior aspect of neurocranium. A, *Zaniolepis latipinnis*; B, *Pleurogrammus azonus*; C, *Oxylebius pictus*; D, *Ophiodon elongatus*; E, *Hexagrammos stelleri*. Bars = 5 mm.

with a posterior shaft lying beneath the anterior portion of the parasphenoid. It is sutured dorsally to the ethmoid and laterally to the lateral ethmoid.

The ethmoid forms the anterodorsal border of the cranium. It is overlapped by the frontal. Two projections for the attachment of the ethmo-premaxillary ligament are present on the dorsal region.

The lateral ethmoid is connected with the frontal dorsally, the ethmoid anteriorly, the prevomer ventrally and the parasphenoid posteriorly. Its anteromedial wall bears the olfactory tract foramen. Two articular heads are present, the anterior head receiving the dorsal process of the lachrymal and the posterior head the palatine. Preocular spines are absent.

The frontal is the largest bone forming the anterior half of the dorsal skull roof, being attached to the supraoccipital, parietal and pterotic posteriorly, the ethmoid and lateral ethmoid anteriorly and the sphenotic and pterosphenoid posteroventrally. The posterolateral surface is smooth. A cartilaginous region is absent on the ventral face.

The parietal, lying on the posterodorsal region of the skull, is sutured to the epiotic posteriorly, the supraoccipital medially, the frontal anteriorly and the pterotic laterally. It contains a sensory canal but lacks spines on the dorsal surface. The posterior region is not covering the dorsal arm of the posttemporal.

The sphenotic forms the posterodorsal corner of the orbit, being attached to the frontal anteriorly, the pterotic posteriorly, the pterosphenoid anteroventrally and the prootic ventrally. It forms the socket for the anterodorsal condyle of the hyomandibular.

The pterosphenoid forms the posterodorsal wall of the orbit, being connected with the frontal anterodorsally, the prootic and basisphenoid ventrally and the sphenotic posteriorly. It is also attached to the parasphenoid in the orbit.

The basisphenoid typically bridges the posteroventral margin of the orbit (Fig. 6), being attached to the pterosphenoid and prootic dorsally, and to the parasphenoid ventrally.

The prootic forms the posteroventral wall of the orbit and the anteroventral wall of the auditory bulla. It is attached to the pterosphenoid and parasphenoid anteriorly, the basioccipital, exoccipital and intercalar posteriorly, the pterotic and sphenotic dorsally and the parasphenoid ventrally. The trigemino-facial chamber, located in the anterodorsal area, contains three foramina for cranial nerves III, V and VII. Typically, the three foramina are similarly sized. A small carotid foramen occurs on the prootic-parasphenoid suture.

The pterotic forms the dorsolateral part of the cranium. It is connected with the frontal and sphenotic anteriorly and the parietal and epiotic medially, and also forms the posttemporal fossa. This bone bears a canal laterally for the cephalic lateral line system, and an elongated socket anterolaterally for the facet of the hyomandibular.

The epiotic lies on the posterior region of the cranium. It is sutured to the parietal anteriorly, the supraoccipital medially, the pterotic ventrally and the exoccipital posteriorly.

The intercalar occupies the posteroventral part of the cranium. It typically meets the prootic anteriorly, the pterotic dorsally and the exoccipital ventrally.

The posterior border of the intercalar forms a facet for articulation with the ventral limb of the posttemporal.

The supraoccipital forms the posterior roof of the skull. It typically makes contact with the frontal anteriorly, the parietal and epiotic laterally, and the exoccipital ventrally. A supraoccipital crest is absent in *Oxylebius* and *Zaniolepis*, but exists as a relatively thin and rounded crest in *Hexagrammos*, *Pleurogrammus* and *Ophiodon* (Figs. 6-8).

The exoccipital forms the posterior wall of the cranium, meeting the supraoccipital dorsally, the pterotic and prootic anteriorly, the intercalar and epiotic dorsolaterally and the basioccipital ventrally. It forms the foramen magnum posteriorly. In addition, the exoccipital bears a condyle for articulation with the first vertebra. Two nerves, IX and X pass through foramina on its lateral surface.

The basioccipital occupies the posteroventral part of the cranium, making contact with the exoccipital dorsally, the prootic anteriorly, and the parasphenoid ventrally, and forming a condyle for articulation with the first vertebra. Typically, Baudelot's ligament is attached to its lateral surface.

The parasphenoid forms the ventral part of neurocranium, having mid-lateral wings, which are attached to the pterosphenoid and prootic (Fig. 6). It is connected with the prevomer anteriorly and with the basioccipital posteriorly.

Character argumentation. Seven neurocranium characters were recognized and polarized (Characters 8-14).

I. Apomorphic characters found in "Hexagrammoidei"

Character 8. Parasphenoid attached to pterosphenoid

According to Quast (1965), this character separates the hexagrammid-cottid group from the scorpaenid group. This condition was found in all "Hexagrammoidei". Since these bones are separated from each other by the intervention of the prootic in basal acanthopterygians, the attached condition is considered apomorphic. The apomorphic state was observed in all cottoids and anoplomatoids examined (these bones are connected by connective tissue in *Erilepis*).

Character 9. Presence of a relatively thin, rounded supraoccipital crest

This crest condition is characterized by the lack of a well-developed posterior part above the exoccipital, and was found only in *Hexagrammos*, *Pleurogrammus* and *Ophiodon* among the Scorpaeniformes. Since basal acanthopterygians do not possess such a supraoccipital crest, the presence of a relatively thin, rounded crest is considered to be a derived condition. The crest size varied in the above three genera, suggesting its possible relationship with the advance of epaxialis on the neurocranium.

II. Apomorphic characters absent in "Hexagrammoidei", but present in other Scorpaeniformes

Character 10. Presence of preocular spine

A preocular spine on the dorsoposterior portion of the lateral ethmoid has been noted in some scorpaeniforms (e.g., Matsubara, 1943a; Matsubara and Ochiai, 1955; Eschmeyer, 1969). This condition was found here in all platycephaloids and many scorpaenoids examined. Since basal acanthopterygians do not have such a spine, its presence is considered apomorphic.

Character 11. Presence of spines on postorbital region of skull

According to Eschmeyer (1969), spines, such as the supraorbital, postorbital, tympanic and coronal spines, occur on the postorbital region of the skull in the Scorpaenidae. The presence of such spines was confirmed in all scorpaenids, except *Paracentropogon*, and the platycephaloids, *Bembras* and *Suggrundus*. Their presence is considered apomorphic, owing to the absence of such spines in basal acanthopterygians.

Character 12. Presence of parietal-nuchal spines

Parietal and nuchal spines on the posterodorsal region of the neurocranium (see Eschmeyer, 1969), were confirmed in all scorpaenids examined, except *Apistus* and *Paracentropogon*, as well as in all synanceiids and platycephaloids. Since basal acanthopterygians lack such spines, their presence is regarded as derived.

Character 13. Anterodorsal arm of posttemporal covered by parietal

This condition was observed in all scorpaenids examined, except *Setarches* and *Paracentropogon*, as well as in the synanceiids. Since the posttemporal anterodorsal arm in basal acanthopterygians is not covered by the parietal, the above condition is considered derived.

Character 14. Presence of narrow cartilaginous band on ventral face of frontal

According to Kido (1988), a narrow cartilaginous band on the ventral face of the frontal is characteristic of his Liparididae. This condition was found in the Liparinae examined, is thought to be apomorphic, owing to its absence in basal acanthopterygians.

III. Other characters

Nasal spine

A well-developed nasal spine was observed in *Zaniolepis*, cottids and some scorpaenids. Since the character was variable in *Hexagrammos*, it could not be used in the analysis.

3. Jaws (Figs. 9-13)

Description. All "hexagrammoids" have the premaxillary and maxillary in the upper jaw, and the dentary, anguloarticular, retroarticular and coronomeckelian in the lower jaw. A supramaxillary is absent. Two cartilaginous elements (rostral cartilage in the upper jaw and the Meckelian cartilage in the lower) support the jaws.

Upper jaw elements. The premaxillary is a toothed, L-shaped bone, with four developed processes: the ascending process, articular process, alveolar process and postmaxillary process (Fig. 9). The ascending process is attached to the rostral cartilage on its posterior face (Fig. 10A). The articular process is located closely to the ascending process, with a deep notch usually present between the two (absent in *Oxylebius*). The alveolar process bears teeth on the ventral margin along most of its length. The postmaxillary process is the least developed. A strong palato-premaxillary ligament connects the ascending process with the palatine (Fig. 10A), preventing any anterior protrusion of the former. In addition, the left and right elements are firmly attached to each other by the interpremaxillary ligament. Dentition varies among the genera (Fig. 11). Each tooth is conical in *Zaniolepis*, *Oxylebius* and *Pleurogrammus*. Some significantly large, conical teeth, were found in *Hexagrammos* (Fig. 11C), the smaller, inner teeth also being conical, as in the

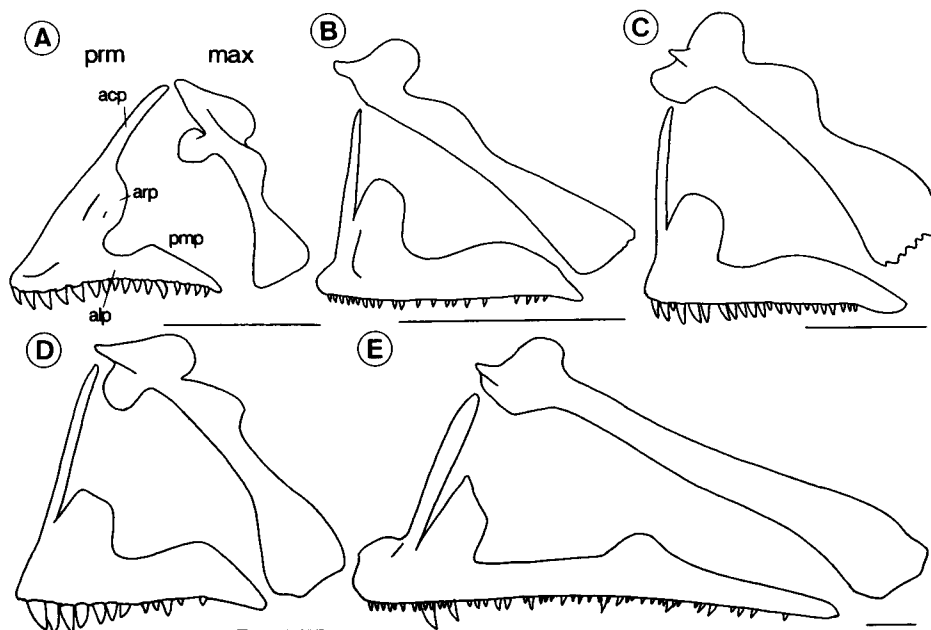

Fig. 9. Lateral aspect of upper jaw. A, *Oxylebius pictus*; B, *Zaniolepis frenata*; C, *Pleurogrammus azonus*; D, *Hexagrammos decagrammus*; E, *Ophiodon elongatus*. Bars = 5 mm.

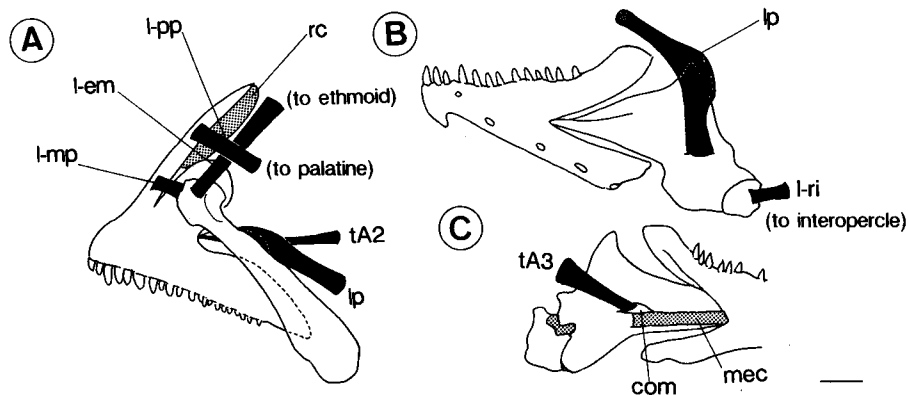

Fig. 10. Buccal ligaments of *Hexagrammos decagrammus*. A, upper jaw (lateral view); B, lower jaw (lateral view); C, lower jaw (medial view). Bar = 3 mm.

above mentioned genera. A few canine teeth occurred with conical teeth in *Ophiodon* (Fig. 11E), the former being located on the anteromedial area of the upper jaw.

The maxillary is characterized by distinct head (maxillary head) and shaft. Two condyles are occurred on the head, the anterior condyle articulating with the articular process of the premaxillary and the posterior one with the anterior process

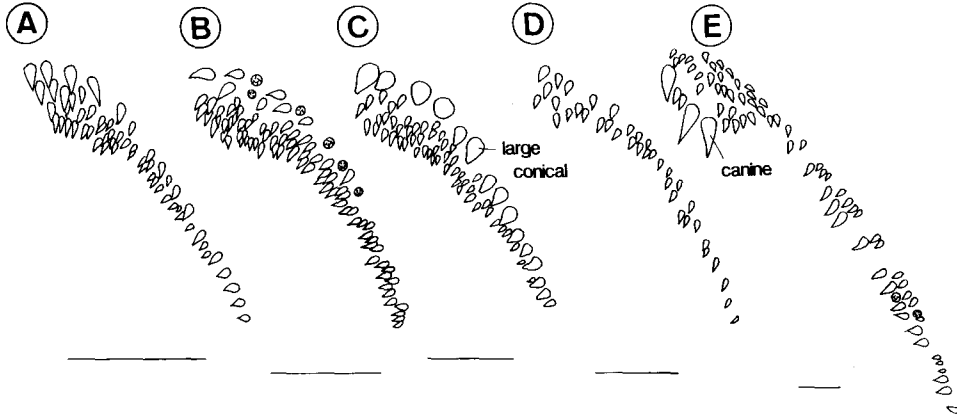

Fig. 11. Dentition of upper jaw (ventral view of left premaxillary). A, *Oxylebius pictus*; B, *Zaniolepis frenata*; C, *Hexagrammos otakii*; D, *Pleurogrammus monoptyerygius*; E, *Ophiodon elongatus*. Bars=3 mm.

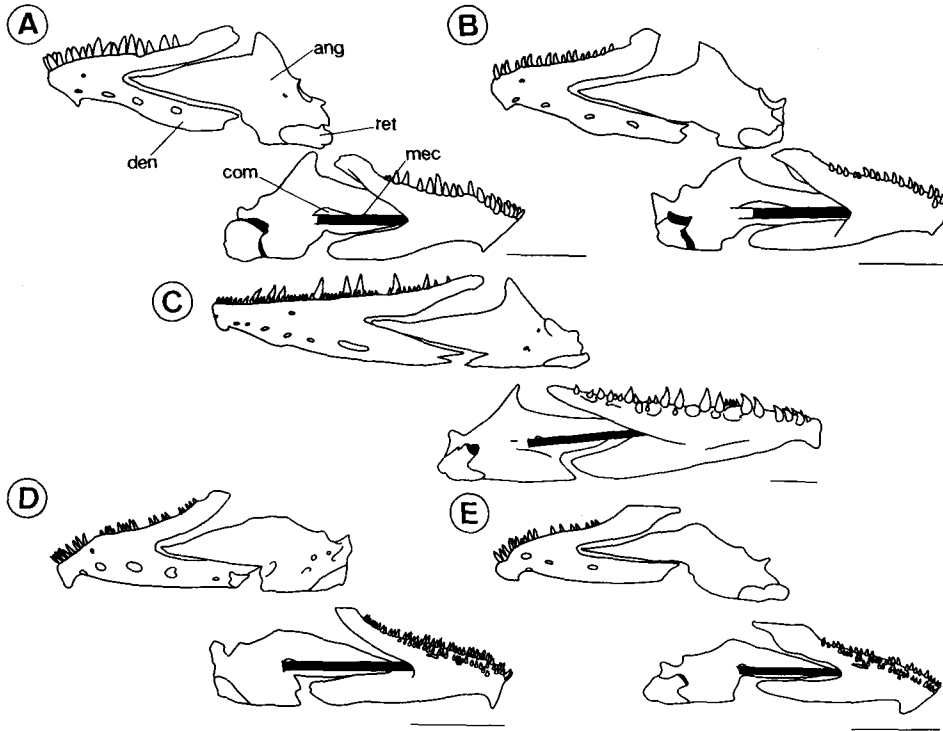

Fig. 12. Lateral (above) and medial (below) aspects of lower jaw. A, *Hexagrammos decagrammus*; B, *Pleurogrammus azonus*; C, *Ophiodon elongatus*; D, *Zaniolepis frenata*; E, *Oxylebius pictus*. Bars=5 mm.

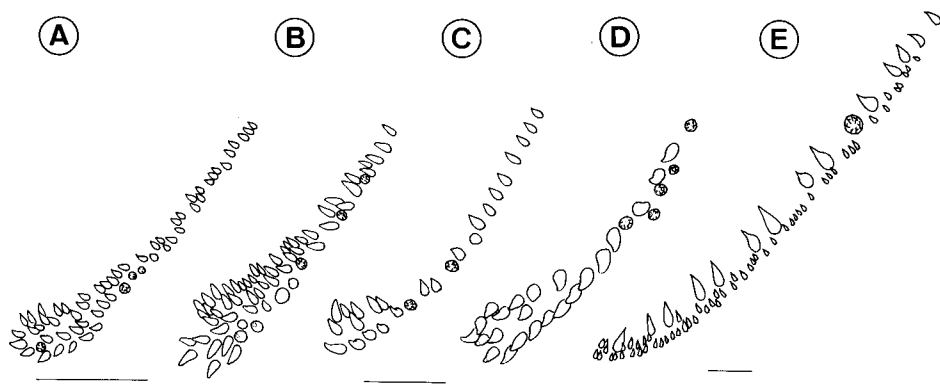

Fig. 13. Dentition of lower jaw (dorsal view of left dentary). A, *Zaniolepis latipinnis*; B, *Oxylebius pictus*; C, *Pleurogrammus azonus*; D, *Hexagrammos lagocephalus*; E, *Ophiodon elongatus*. Bars=3 mm.

of the palatine. In addition, the maxillary head is connected to the premaxillary anteriorly by the maxillo-premaxillary ligament, and to the ethmoid dorsally by the ethmo-maxillary ligament (Fig. 10A). The shaft is long, serving as the attachment site for the ligamentum primordium.

Lower jaw elements. The dentary is toothed, bearing a hyomandibular sensory canal along the entire length of its ventral surface. As in the upper jaw, dentition varies, with canines on the inner row and small conical teeth on the outer rows in *Ophiodon*, and only conical teeth in the other genera (Fig. 13). A symphyseal knob is present at the anteriormost region. A small exit for the trigeminal nerve (=ramulus mandibularis externus trigeminus) occurs on the dorsolateral surface. The right and left elements are firmly attached to each other at the anteriormost point. Medially, the dentary is attached to the rod-like Meckelian cartilage, which runs between the former and the anguloarticular.

The anguloarticular is lozonge-shaped, its anterior projection fitting into the notch of the dentary. It bears a prominent ascending process on the posterodorsal region in *Hexagrammos*, *Pleurogrammus* and *Ophiodon*, but lacks such in *Oxylebius* and *Zaniolepis* (Fig. 12). It also serves posteriorly as an articular condyle for the quadrate. A hyomandibular sensory canal, which continues to the dentary, runs through the posterior part of the anguloarticular, which also has the ligamentum primordium originating from its lateral side (Fig. 10B). A tiny coronomeckelian fits into the groove between the anguloarticular and the Meckelian cartilage.

The retroarticular is a small, trapezoid bone, forming the posteroventral corner of the lower jaw. It is sutured anterodorsally with the anguloarticular, and is connected with the interopercle by the retroarticulo-interopercular ligament (Fig. 10B).

The coronomeckelian is a tiny bone, located on the medial side of the anguloarticular near the posterior end of the Meckelian cartilage. It supplies the attachment site for the A3 section of the adductor mandibulae (Fig. 10C).

Character argumentation. Five jaw characters were recognized and polarized (Characters 15-19).

I. Apomorphic characters found in "Hexagrammoidei"

Character 15. Reduction of ascending process of anguloarticular

This condition was found in *Zaniolepis* and *Oxylebius*. It is considered apomorphic because an ascending process of the anguloarticular is developed in basal acanthopterygians. In the other Scorpaeniformes, the same apomorphic condition was observed only in *Anoplopoma*.

Character 16. Hexagrammos-type dentition in upper jaw

The *Hexagrammos*-type dentition, with large, conical teeth present in the outer row and small conical teeth in the inner rows (see Fig. 11C), has been found only in *Hexagrammos*, among the Scorpaeniformes (Matsubara and Ochiai, 1955; Yabe, 1985; Kido, 1988; Kanayama, 1991; pers. obs.). Although dentition varies in basal acanthopterygians, the above condition is regarded as apomorphic because of its rarity in the latter.

Character 17. Presence of canines in both jaws

This condition was observed only in *Ophiodon*. It is regarded as apomorphic because of the lack of canines in most basal acanthopterygians.

Character 18. Absence of notch between ascending and articular processes in premaxillary

This condition was observed in *Oxylebius*. Since a notch is present in basal acanthopterygians, its absence is considered apomorphic. The absence of a notch has not been reported in the other scorpaeniforms (Yabe, 1985; Kido, 1988; Kanayama, 1991; pers. obs.).

II. Apomorphic characters absent in "Hexagrammoidei" but present in other Scorpaeniformes

Character 19. Separation of ascending process from remaining part in premaxillary

This condition was observed in *Rogadius*, *Suggrundus* and *Hoplichthys*. Since the ascending process is continuous with the remaining part of the premaxillary in basal acanthopterygians, the above condition is considered apomorphic.

III. Other characters

None.

4. Suspensorium and opercular bones (Figs. 14-16)

Description. The suspensorium comprises the hyomandibular, metapterygoid, quadrate, symplectic, entopterygoid, ectopterygoid and palatine. The opercular bones include four elements: the preopercle, opercle, interopercle and subopercle.

Suspensorium. The hyomandibular is a large bone with a long shaft. It bears three articulating facets on the dorsal edge, two for articulation with the cranium and the other with the opercle. The hyomandibular is connected with the metapterygoid anteriorly and with the preopercle posteriorly. One large entrance of the truncus hyomandibularis nerve is present on the medial face (Fig. 15).

The metapterygoid is a rectangular bone, located posteriorly to the orbit. The anterior margin has a notch, which is prominent in *Ophiodon* (Fig. 14F). Two foramina exist posteriorly. A projection, which receives the levator arcus palatini, is present on its medial face in *Hexagrammos* (Fig. 15B). Anteriorly, the metapterygoid is attached to the entopterygoid. Anterodorsally, it is continuous with the quadrate via a narrow cartilaginous band.

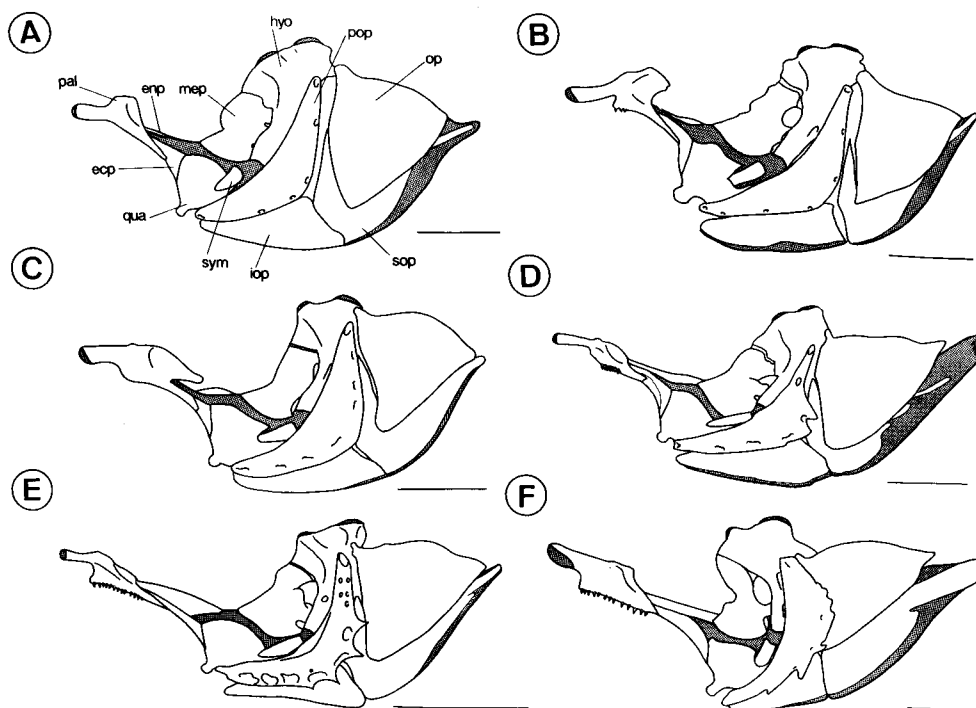

Fig. 14. Lateral aspect of suspensorium and opercular bones. A, *Hexagrammos agrammus*; B, *Hexagrammos decagrammus*; C, *Pleurogrammus azonus*; D, *Oxylebius pictus*; E, *Zaniolepis latipinnis*; F, *Ophiodon elongatus*. Bars=5 mm.

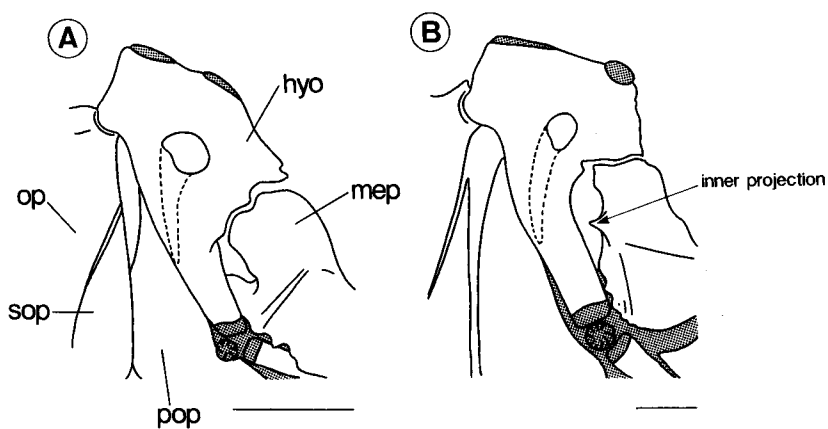

Fig. 15. Medial aspect of suspensorium. A, *Oxylebius pictus*; B, *Hexagrammos stelleri*. Bars=3 mm.

The quadrate is a triangular bone, bearing a large facet on its anteroventral corner for articulation with the anguloarticular. It is sutured to the ectopterygoid anterodorsally, and is clearly separated from the metapterygoid and hyomandibular by a cartilaginous band. A well-developed notch is present for receiving the ventral part of the symplectic. Posteriorly, it is loosely attached to the preopercle.

The symplectic is a rod-like bone. On the medial side, its dorsal head bears a cartilage and forms an articular socket for the interhyal.

The entopterygoid is a small bone, forming the ventral area of the orbit. It is sutured to the palatine anteriorly, and to the ectopterygoid ventromedially. Also, it is continuous posteriorly with the metapterygoid.

The ectopterygoid is a small, trapezoid bone, forming the dorsal portion of the oral cavity. It is surrounded by the palatine, entopterygoid and metapterygoid.

The palatine is a heavy bone with a shaft anteriorly. Two facets on the dorsal surface articulate with the lateral ethmoid. The anterior portion is firmly attached to the anteromedial face of the lachrymal, forming the lachryopalatine articulation (see character argumentation of circumorbital bones). Teeth are absent from the ventral face in *Pleurogrammus* and some members of *Hexagrammos*.

Opercular bones. The preopercle is a semicircular bone, attached to the hyomandibular, quadrate, subopercle and interopercle. It contains an operculo-mandibular canal, with several posterior branches. The canal region is completely covered by the adductor mandibulae in *Hexagrammos*, *Pleurogrammus* and *Ophiodon* (Fig. 16B). The preopercle margin bears blunt spines in *Ophiodon* and *Oxylebius*, and small spines in *Zaniolepis*, but is smooth in *Hexagrammos* and *Pleurogrammus*.

The triangular opercle is the largest opercular bone. On the anterodorsal corner, it bears an articular head for the hyomandibular. It is sutured to the preopercle anteriorly and the subopercle ventrally. A narrow, cartilaginous band is present near its ventral margin.

The subopercle is an L-shaped bone with the vertical arm fitting the anteroventral margin of the opercle. Its dorsoposterior arm slightly overlaps the opercle. Anteriorly, the subopercle is attached to the interopercle.

The triangular interopercle is connected to the retroarticular by the retroarticulo-interopercular ligament. Medially, it bears an articular socket which receives the posterolateral end of the epihyal.

Character argumentation. Two characters of the suspensorium and opercular bones were recognized and polarized (Characters 20, 21).

I. Apomorphic characters found in "Hexagrammoidei"

Character 20. Presence of inner projection on metapterygoid

This condition was found only in *Hexagrammos* (Fig. 15B). Since basal acanthopterygians lack such an inner projection, its presence is considered apomorphic.

Character 21. Operculo-mandibular canal region of preopercle covered by adductor mandibulae

This condition was found only in *Hexagrammos*, *Pleurogrammus* and *Ophiodon* (Fig. 16B). Because this region is not covered by the muscle in basal acanthopterygians, the above condition is considered apomorphic.

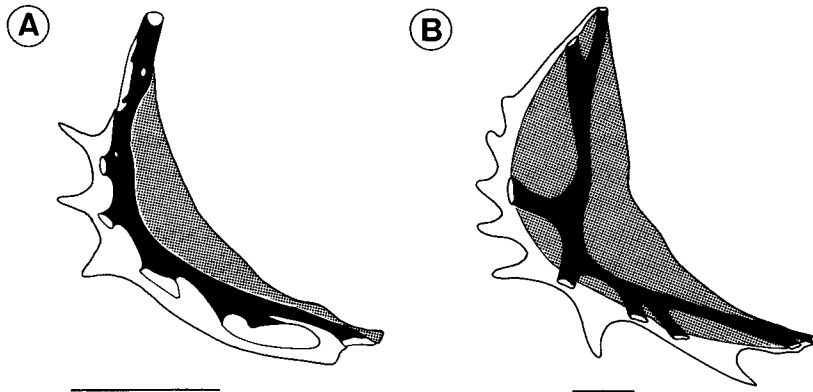

Fig. 16. Lateral aspect of preopercle (right side). A, *Zaniolepis frenata*; B, *Ophiodon elongatus*. Dots, area covered by adductor mandibulae. Bars = 5 mm.

II. Apomorphic characters absent in "Hexagrammoidei", but present in other Scorpaeniformes

None.

III. Other characters

Metapterygoid lamina

A metapterygoid lamina was found in *Oxylebius* and *Zaniolepis* among the "Hexagrammoidei". The same condition was present in all of the scorpaenoids examined, except *Paracentropogon*, *Apistus* and *Inimicus*, and in the platycephaloid, *Rogadius*. In the basal acanthopterygian condition, berycoids having one to many spines. Hence the character was not used in the analysis because its polarity could not be determined.

Number of opercular spines

One opercular spine was observed in all "Hexagrammoidei", as well as in the Anoplopomatoidei and Cottoidei. On the other hand, in the other Scorpaeniformes examined, the opercle bore two spines in the Scorpaenoidei (except *Dendrochirus* with one) and three spines in the Platycephaloidei. Although the character is valuable for separating these groups, its polarity cannot be determined from the basal acanthopterygian condition, berycoids having one to many spines. Therefore, the character was not used in the analysis.

Number and condition of preopercular spines

A variation in the number and condition of the preopercular spines was observed in the Scorpaeniformes, including the "Hexagrammoidei". In the percoids and berycoids examined, the number varied in the former and the condition was complex in both. Therefore, because the polarity of the character could not be determined, it was not used in the analysis.

5. Hyoid arch (Figs. 17-18).

Description. The hyoid arch comprises the dorsal and ventral hypohyals, ceratohyal, epihyal, interhyal, basihyal (described in the branchial arches),

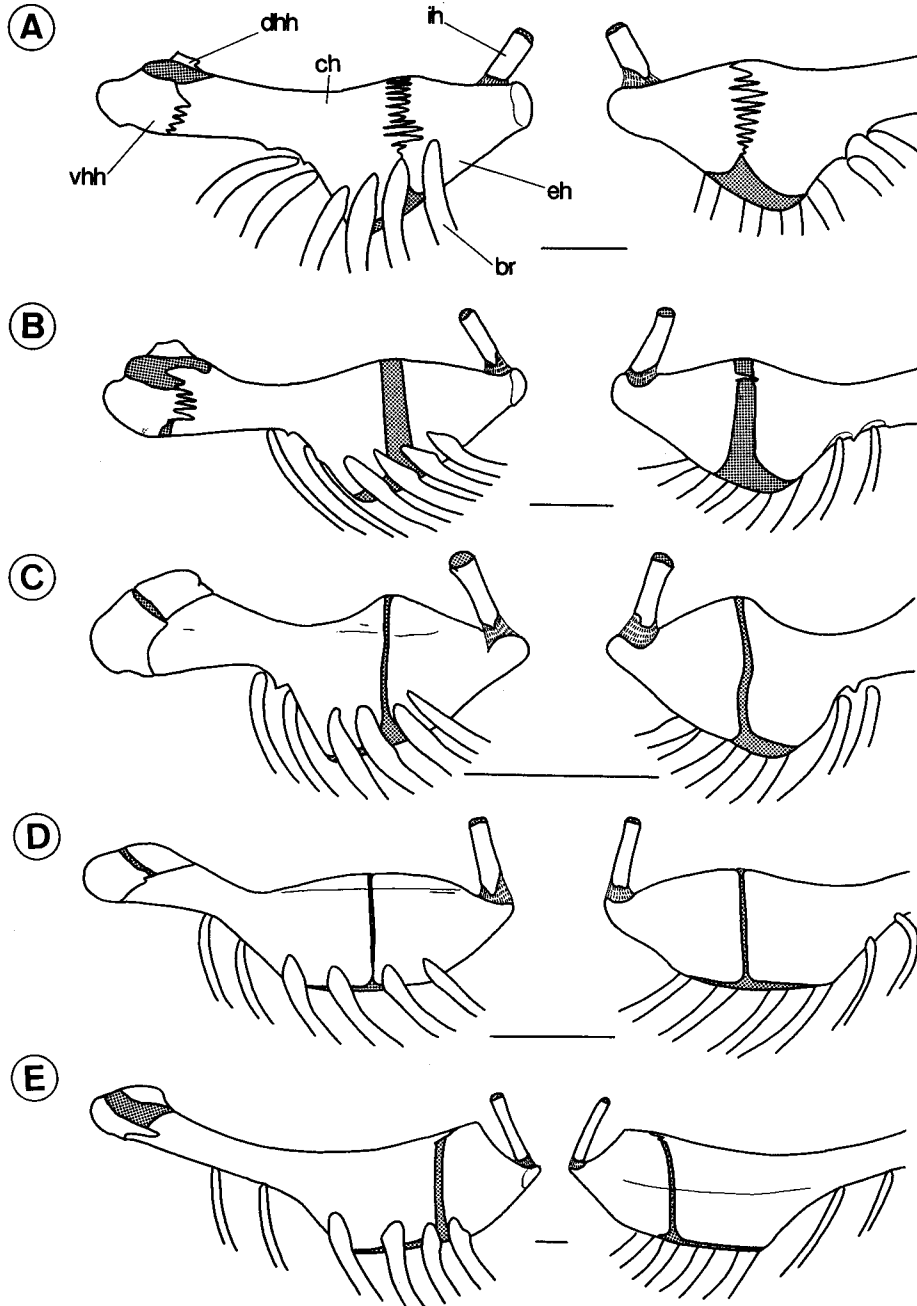

Fig. 17. Lateral (left) and medial (right) aspects of hyoid arch. A, *Hexagrammos decagrammus*; B, *Pleurogrammus azonus*; C, *Oxylebius pictus*; D, *Zaniolepis frenata*; E, *Ophiodon elongatus*. A, B and E: bars=5 mm; C and D: 3 mm.

branchiostegal rays and urohyal. All of the basal elements of the Acanthopterygii are present in the "Hexagrammoidei".

The hypohyals are small bones, comprising two elements, dorsal and ventral, located at the anteriormost region of the hyoid arch. The dorsal hypohyal, forming the anteroventral area of the oral cavity, bears a knob-like projection, which is connected to the anteriormost basibranchial and basihyal by strong connective tissue. The ventral hypohyal is connected to the urohyal by a strong ligament. Both hypohyals interdigitate posteriorly with the ceratohyal.

The ceratohyal is a large, flattened bone, having shallow anterior and deep posterior parts. Sandwiched by the hypohyals and epihyal, its ventral margin suspends the heads of the anterior branchiostegal rays. The beryciform foramen and groove for the hyoidean artery are absent.

The triangular epihyal posteriorly bears a well-developed articular head for the facet on the medial face of the interopercle. It also articulates with the interhyal near the posterodorsal margin and supports the posterior branchiostegal rays.

The interhyal is a tiny, rod-like bone, linking the hyoid arch to the suspensorium. Dorsally, it fits into the cartilaginous area between the hyomandibular and symplectic, being supported by connective tissue. Ventrally, it is attached to the posterior corner of the epihyal, this connection also being supported by strong connective tissue.

Six, long, curved branchiostegal rays are present, the roughly four anterior ones being attached to the ceratohyal and the remainder to the epihyal.

The urohyal (unpaired) is a flattened, rectangular bone (Fig. 18), with a small dorsal projection (=dorsal attachment of Kusaka, 1974). It is connected to the lower hypohyal by a strong ligament.

Character argumentation. Three hyoid arch characters were recognized and polarized (Characters 22-24).

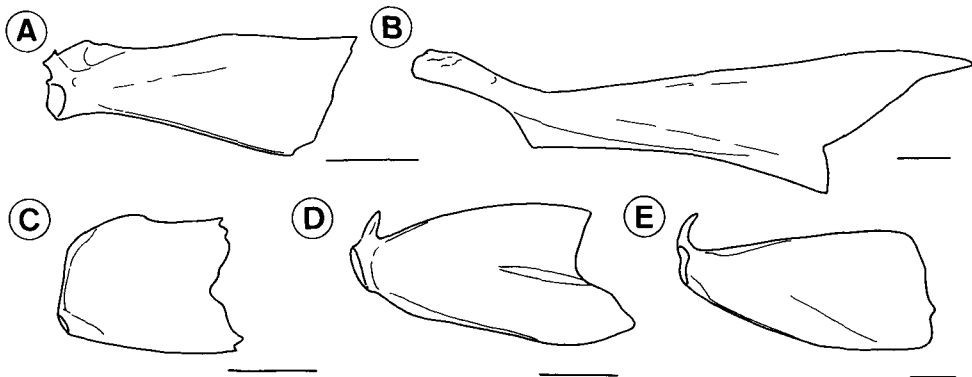

Fig. 18. Lateral aspect of urohyal. A, *Zaniolepis frenata*; B, *Ophiodon elongatus*; C, *Oxylebius pictus*; D, *Hexagrammos otakii*; E, *Pleurogrammus monoptyerygius*. Bars = 3 mm.

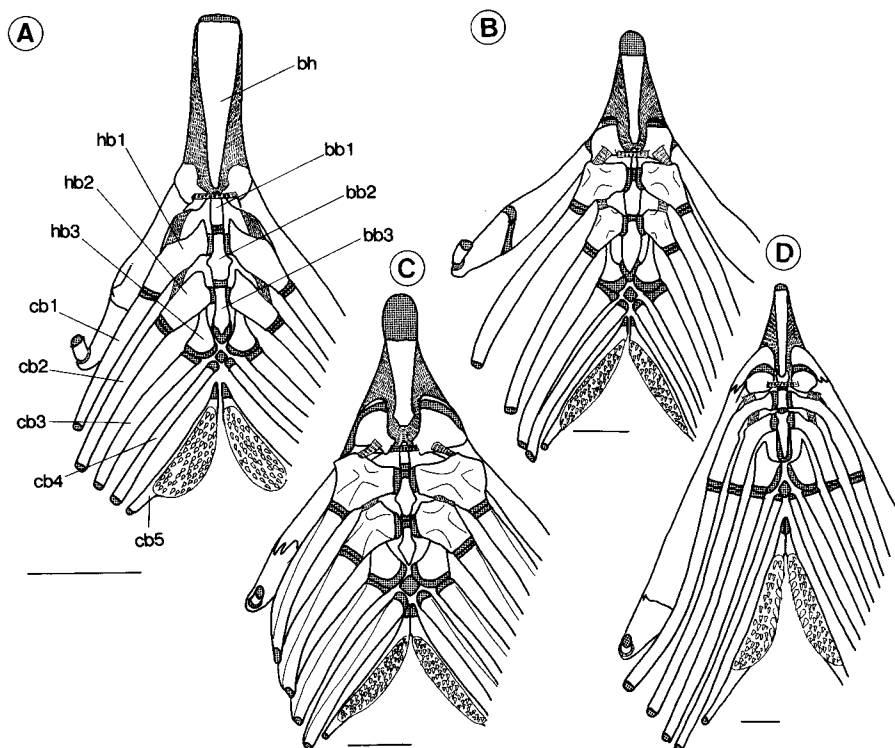

Fig. 19. Dorsal aspect of lower branchial arches. A, *Oxylebius pictus*; B, *Pleurogrammus azonus*; C, *Hexagrammos otakii*; D, *Ophiodon elongatus*. Bars = 5 mm.

I. Apomorphic characters found in "Hexagrammoidei"

Character 22. Six branchiostegal rays

All "hexagrammoids" have six branchiostegal rays. Since basal acanthopterygians have at least seven branchiostegal rays, the reduction to six is considered apomorphic. From the topological view point, the loss of the anteriormost ray(s) in species having seven (eight or more) is considered the cause of the apomorphic condition. Therefore, every example of six branchiostegals in the "hexagrammoid" genera is thought to be homologous. In the other scorpaeniforms, *Paracentropogon*, all anoplomatoids and all cottoids, except the psychrolutids, share the same apomorphy with the "Hexagrammoidei".

Character 23. Absence of beryciform foramen

All "hexagrammoids" lack the beryciform foramen. Since it is present in basal acanthopterygians, its loss is considered apomorphic. The same apomorphic condition was observed in all scorpaenoids, platycephaloids and anoplomatoids examined with one cottoid (*Blepsias*).

II. Apomorphic characters absent in "Hexagrammoidei", but present in other Scorpaeniformes

Character 24. Absence of basihyal

The basihyal was found to be absent in three genera of the scorpaenoids (*Paracentropogon*, *Chelidonichthys* and *Peristedion*) and all cottoids examined. Since basal acanthopterygians possess a basihyal, the loss of such is considered apomorphic.

III. Other characters

None.

6. Branchial arches (Figs. 19-22).

Description. The branchial arches consist of the basibranchial, hypobranchial, ceratobranchial, epibranchial and pharyngobranchial. The basihyal is also described in this section because it is one of the elements comprising the floor of the oral cavity.

Lower branchial arch elements. The basibranchials are three small, well ossified, stick-like bones, arranged on the midline of the oral floor. The first, being the smallest, is located below the small ligament between the left and right dorsal hypohyals (Figs. 19, 20). The second is sandwiched by the first hypobranchials, and the third by the second hypobranchials.

The hypobranchials are three paired bones, becoming progressively smaller posteriorly, located between the basibranchial and ceratobranchial. The first is connected to the dorsal hypohyal by a ligament. The other ligament is present between the first and second hypobranchials. The shape of the first is rod-like in

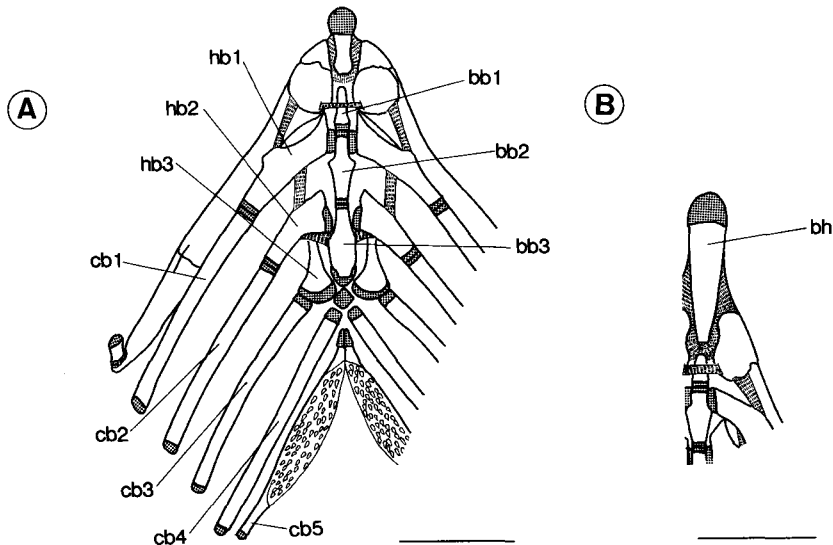

Fig. 20. Dorsal aspect of lower branchial arches in two species of *Zaniolepis*. A, *Z. frenata*; B, *Z. latipinnis* (anterior part). Bars=5 mm.

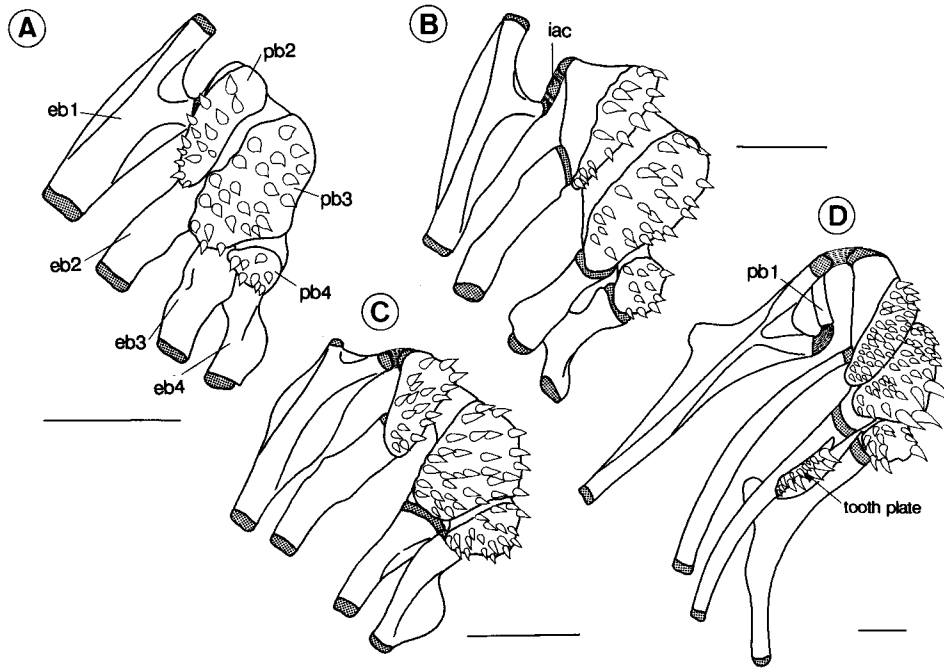

Fig. 21. Ventral aspect of upper branchial arches. A, *Hexagrammos stelleri*; B, *Pleurogrammus azonus*; C, *Oxylebius pictus*; D, *Ophiodon elongatus*. Bars=5 mm.

Ophiodon and *Zaniolepis* or nearly so (partly expanded) in *Oxylebius*. However, it is polygonal and plate-like in *Hexagrammos* and *Pleurogrammus*. A similar, but not so obvious trend was observed in the second hypobranchial. The third hypobranchial forms a longitudinal plate, with an anterior projection extending below the second.

There are five paired ceratobranchials. The first three are situated between the hypobranchials and epibranchials, and the fifth, bearing a tooth plate on its dorsal surface, between the fourth ceratobranchials.

The basihyal is a rod-like or slightly triangular bone, bearing a cartilage on the tip. It is usually long horizontally, but extremely small in *Zaniolepis frenata* (Fig. 20A).

Upper branchial arch elements. The epibranchials are four paired, stick-like bones, forming the dorsolateral wall of the pharynx, and articulating with the ceratobranchials distally and the pharyngobranchials proximally. The first epibranchial bears an uncinat process, which is connected to the anteromedial corner of the second pharyngobranchial by a ligament. An interarcual cartilage is present in the ligament in *Pleurogrammus* and *Zaniolepis*, but its presence or otherwise was not certain in the other genera (Figs. 21, 22). The second to fourth epibranchials are sandwiched by the second to fourth ceratobranchials and pharyngobranchials, respectively. A tooth plate is borne on the third epibranchial in *Ophiodon* (Fig. 21D). The last epibranchial bears a dorsal flange.

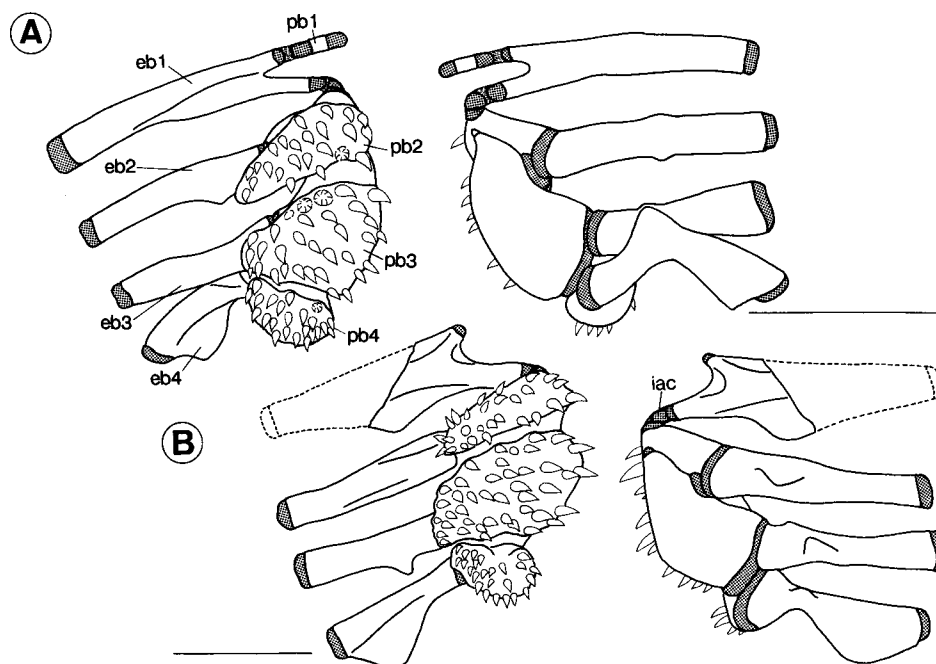

Fig. 22. Ventral (left) and dorsal (right) aspects of upper branchial arches in two species of *Zaniolepis*. A, *Z. frenata*; B, *Z. latipinnis*. Bars=5 mm.

Three (second to fourth) pharyngobranchials, each with a tooth plate, are usual, the first (=suspensory), which lacks teeth, being present in *Ophiodon* and one species of *Zaniolepis* (*Z. frenata*). Both the third pharyngobranchial and its tooth plate are the largest among the respective elements.

Character argumentation. Three branchial arch characters were recognized and polarized (Characters 25-27).

I. Apomorphic characters found in "Hexagrammoidei"

Character 25. Hypobranchials polygonal and plate-like

The hypobranchials are polygonal and plate-like in *Hexagrammos* and *Pleurogrammus*, but rod-like in the other genera. Since basal acanthopterygians have rod-like hypobranchials, the condition found in *Hexagrammos* and *Pleurogrammus* is regarded as apomorphic. Within the Scorpaeniformes this character state is unique to the above two genera.

Character 26. Absence of tooth plate on third epibranchial

The presence of a tooth plate on the third epibranchial in *Ophiodon* is considered plesiomorphic since basal acanthopterygians are similarly characterized. Although the remaining "hexagrammoid" genera (*Hexagrammos*, *Pleurogrammus*, *Oxylebius* and *Zaniolepis*) possess the derived condition (absence of the tooth plate), the condition was also found in *Paracentropogon*, *Minous*, *Inimicus*, *Erispex*, *Peristedion*, and all anoplomatoids and cottoids examined.

II. Apomorphic characters absent in "Hexagrammoidei" but present in other Scorpaeniformes

Character 27. Presence of cartilaginous second and third basibranchials

Cartilaginous basibranchials were found in *Liparis*, *Careproctus* and *Eumicrotremus*. Kido (1988) considered the condition to be a synapomorphy of the Cyclopteridae. Since basal acanthopterygians have ossified basibranchials, the cartilaginous condition in the scorpaeniforms is considered apomorphic.

III. Other characters

Absence of suspensory pharyngeal

The absence of a suspensory pharyngeal is considered to be apomorphic in the Scorpaeniformes because of its usual occurrence in the acanthopterygians (Rosen, 1973). However, because of the intrageneric variation found in *Zaniolepis* (Fig. 22), the character was not used in the analysis.

7. Pectoral girdle (Figs. 23-28)

Description. The pectoral girdle is made up of the supratermporal, posttemporal, supracleithrum, cleithrum, postcleithrum, scapula, coracoid and actinosts.

The tube-like supratermporal is located over the posttemporal fossa, and carries a cephalic sensory canal, which is continuous with the canal of the sphenotic, parietal and posttemporal. One supratermporal was found only in *Hexagrammos* and *Pleurogrammus*, but two in all the other genera (Fig. 23).

The posttemporal is a forked bone, bearing dorsal and ventral limbs anteriorly. The dorsal limb is firmly attached to the epiotic, and the ventral to the intercalar. A canal structure is present for the lateral line system.

The supracleithrum is a leaf-like bone, which connects the posttemporal to the cleithrum. The medial face is linked to the Baudelot's ligament.

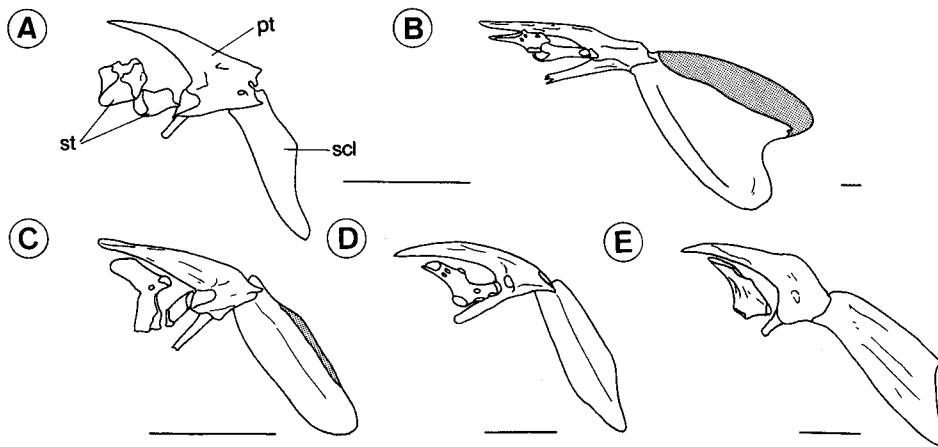

Fig. 23. Lateral aspect of upper part of pectoral girdle. A, *Zaniolepis latipinnis*; B, *Ophiodon elongatus*; C, *Oxylebius pictus*; D, *Pleurogrammus azonus*; E, *Hexagrammos stelleri*. A: bar=3 mm; B-E: 5 mm.

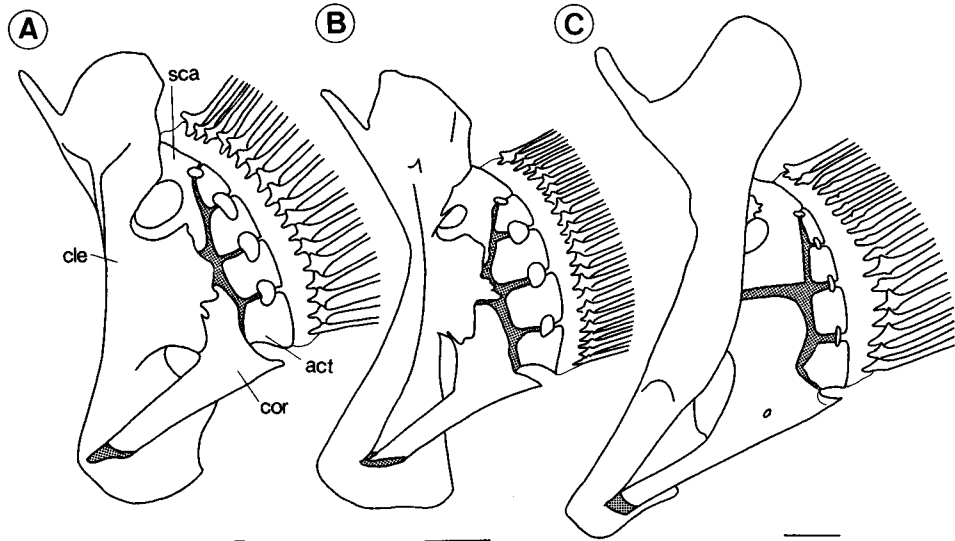

Fig. 24. Lateral aspect of lower part of pectoral girdle. A, *Hexagrammos otakii*; B, *Pleurogrammus azonus*; C, *Ophiodon elongatus*. Bars=3 mm.

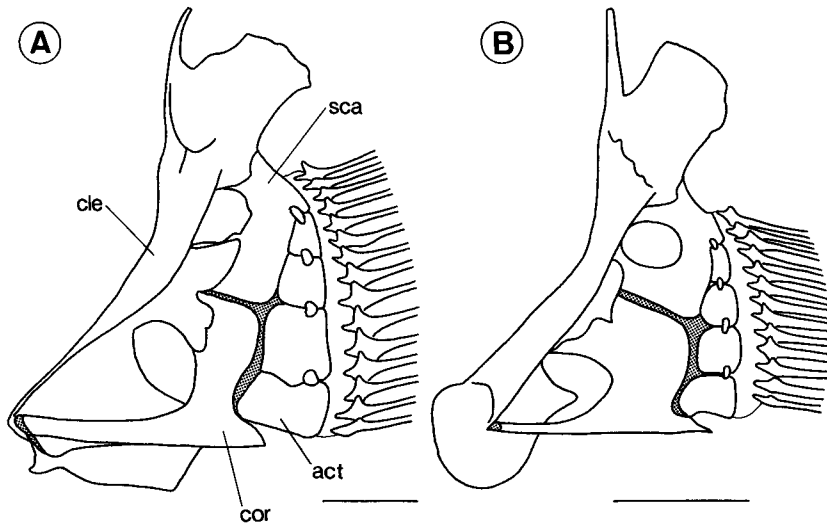

Fig. 25. Lateral aspect of lower part of pectoral girdle. A, *Oxylebius pictus*; B, *Zaniolepis latipinnis*. Bars=3 mm.

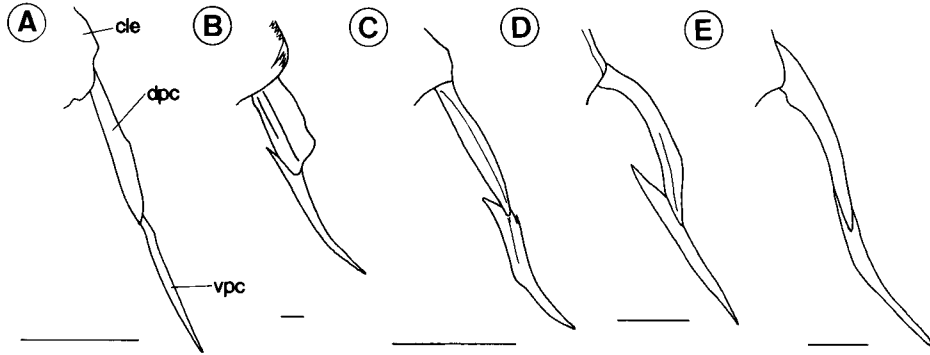

Fig. 26. Lateral aspect of postcleithra. A, *Zaniolepis latipinnis*; B, *Ophiodon elongatus*; C, *Oxylebius pictus*; D, *Pleurogrammus azonus*; E, *Hexagrammos stelleri*. A: bar=3 mm; B-E: 5 mm.

The cleithrum is the largest bone in the pectoral girdle, having a shield-like structure anteriorly. The dorsal limb bears a deep depression for receipt of the supracleithrum. No accessory spines were seen on the posterodorsal region (Fig. 28A). The ventral limb bears a flange, forming a pocket which receives the lateral pectoral muscles. It also has a shallow groove on the anterior region of the flange.

The roughly rectangular scapula is sutured anterodorsally to the cleithrum and perforated by a scapular foramen. The dorsoposterior region bears a narrow cartilaginous band to which the upper pectoral-fin rays are attached.

Four, anvil-shaped actinosts were found, supporting all but the uppermost pectoral-fin rays. The two upper actinosts are attached to the scapula, and the remaining two to the coracoid.

The coracoid bears a ventral arm, which is attached to the cleithrum. The arm is slim in *Ophiodon*, *Oxylebius* and *Zaniolepis*, but robust and firmly attached to the cleithrum in *Hexagrammos* and *Pleurogrammus* (Fig. 27).

The postcleithra are long, thin bones, comprising dorsal and ventral elements

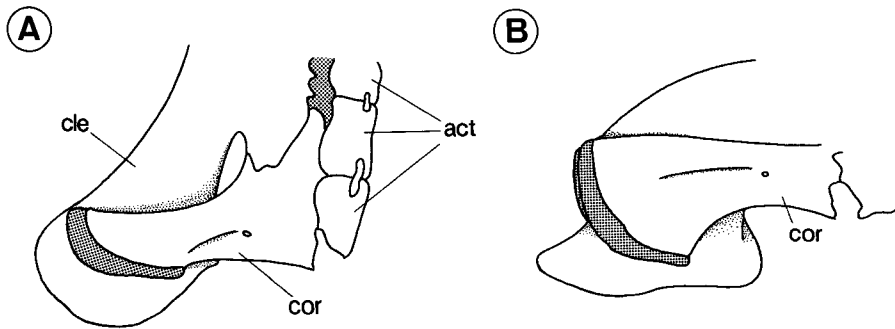

Fig. 27. Coracoid-cleithrum articulation in *Hexagrammos stelleri*. A, lateral view; B, ventral view. Bar=5 mm.

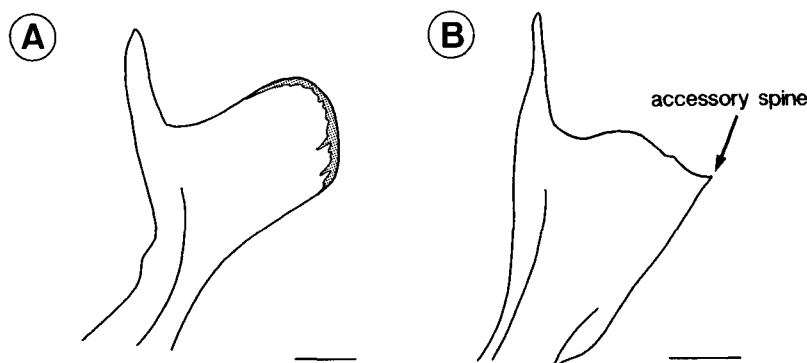

Fig. 28. Lateral aspect of upper part of cleithrum. A, *Ophiodon elongatus*; B, *Hozukius emblemarius* (Scorpaenidae). Bars=5 mm.

(Fig. 26). The dorsal element is crescentic and the other rod-like.

Character argumentation. Four pectoral girdle characters were recognized and polarized (Characters 28-31).

I. Apomorphic characters found in "Hexagrammoidei"

Character 28. Coracoid arm robust and broadly attached to cleithrum

This condition was unique to *Hexagrammos* and *Pleurogrammus* in the materials examined (Fig. 27). Since the coracoid arm is slim and loosely attached to the cleithrum in basal acanthopterygians, the above condition is considered apomorphic.

II. Apomorphic characters absent in "Hexagrammoidei", but present in other Scorpaeniformes

Character 29. First actinost fused to scapula

This condition was observed in all scorpaenids examined, except *Setarches*, *Pontinus*, *Scorpaenodes*, *Dendrochirus* and *Sebastolobus*, as well as in the synanceiids and aploactinids. It is considered apomorphic because the first actinost is not fused to the scapula in basal acanthopterygians.

Character 30. All actinosts sandwiched by scapula and coracoid

This situation was observed in the cyclopterids, *Liparis*, *Careproctus* and *Eumicrotremus*. It is considered apomorphic because the actinost series in basal acanthopterygians is situated posterior to the scapula and coracoid, not sandwiched by them.

Character 31. Presence of accessory spine on head of cleithrum

An accessory spine on the cleithrum was found in all scorpaenoids, except *Dendrochirus* and *Sebastolobus*, and all platycephaloids examined (Fig. 28B). The condition is regarded as apomorphic because basal acanthopterygians lack such a spine.

III. Other characters

Number of supratemporals

The number of supratemporal bones varies in the Scorpaeniformes (Matsubara, 1943a; Yabe, 1985; Kanayama, 1991; pers. obs.), as well as among basal acanthopterygians [berycoids (1) and percoids (usually 2)] (Tominaga, 1968; Fraser, 1972; Zehren, 1979; Johnson, 1980; Sasaki, 1989). Therefore, it could not be used

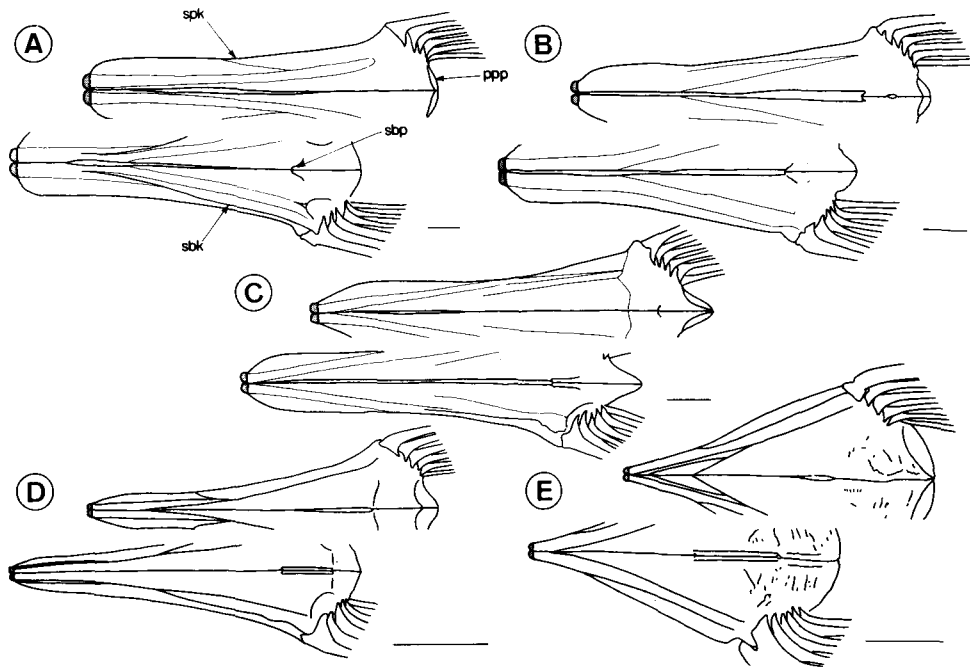

Fig. 29. Dorsal (above) and ventral (below) aspects of pelvic girdle. A, *Pleurogrammus azonus*; B, *Hexagrammos stelleri*; C, *Ophiodon elongatus*; D, *Oxylebius pictus*; E, *Zaniolepis frenata*. Bars=5 mm.

in the analysis.

8. Pelvic girdle (Fig. 29)

Description. The pelvic girdle consists of the triangular pelvis. The posterior regions of the left and right elements are firmly attached to each other along the medial face. A suprapelvic keel is present dorsally, and a subpelvic keel ventrally. Anteriorly, the pelvis is firmly attached to the ventromedial region of cleithrum. It articulates with a spine and five soft-rays posteriorly. A subpelvic process is present on the ventral surface, and a postpelvic process posteriorly, the latter bearing a shallow groove dorsally for receiving the body muscle.

Character argumentation. Two pelvic girdle characters were recognized and polarized (Characters 32, 33).

I. Apomorphic characters found in "Hexagrammoidei"

None.

II. Apomorphic characters absent in "Hexagrammoidei", but present in other Scorpaeniformes

Character 32. Presence of sucking disc

This condition, found in *Liparis*, *Careproctus* and *Eumicrotremus*, is absent in basal acanthopterygians, and is therefore considered apomorphic.

Character 33. Decrease in number of soft rays in pelvic fin

The number of pelvic soft rays was found to be four or less in *Erisphex*, *Paracentropogon*, and all cottoids, except the cyclopterids. Since basal acanthopterygians have five or more soft rays, a reduction from five is considered apomorphic.

III. Other characters

None.

9. Axial skeleton and median fin supports (Figs. 30-33)

Description. The axial skeleton includes the vertebrae, and pleural and epi-pleural ribs. The median fin supports consist of the predorsal, and proximal and distal pterygiophores.

Axial skeleton. The vertebrae comprise abdominal and caudal elements. Except for the two anteriormost vertebrae, vertebral attachment to the pleural ribs is direct or via a parapophysis. Neural arches are present, each bearing a dorsal spine. The first neural spine is shorter than the succeeding ones in *Hexagrammos*, *Pleurogrammus* and *Ophiodon*. A parapophysis is present laterally on each abdominal vertebra. The caudal vertebrae possess a haemal arch and spine, some caudal vertebrae also bearing epipleurals (Fig. 31).

Each pleural rib is slender and rod-like, being attached to the posterior face of a parapophysis (Fig. 30). They are usually present on the third to last abdominal vertebrae.

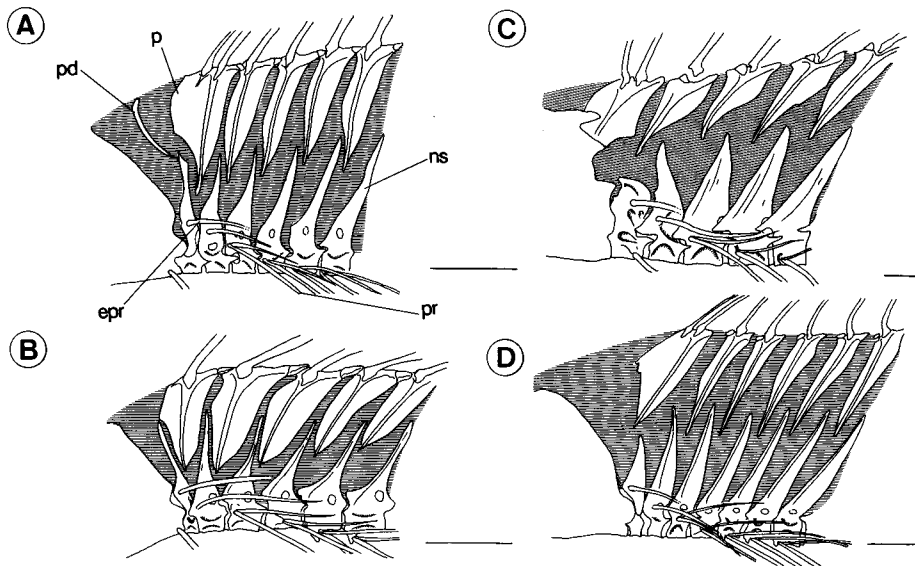

Fig. 30. Lateral aspect of abdominal vertebrae and associated bones. A, *Oxylebius pictus*; B, *Zaniolepis latipinnis*; C, *Ophiodon elongatus*; D, *Hexagrammos octogrammus*. Bars = 5 mm.

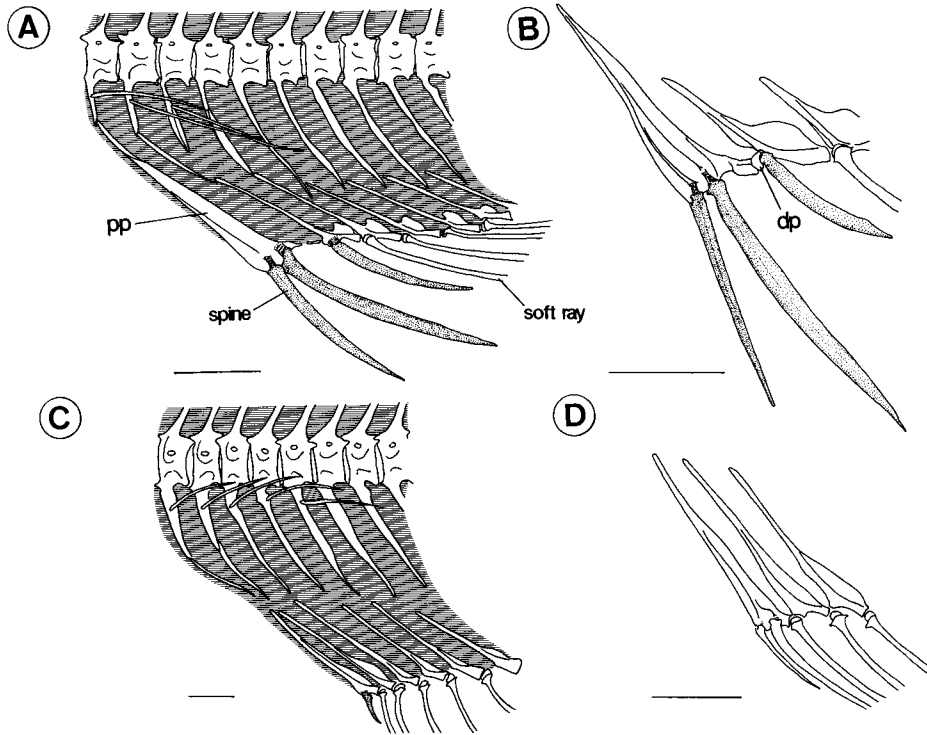

Fig. 31. Lateral aspect of anterior anal pterygiophores and associated bones. A, *Oxylebius pictus*; B, *Zaniolepis frenata*; C, *Hexagrammos decagrammus*; D, *Pleurogrammus monoptyerygius*. Bars = 5 mm.

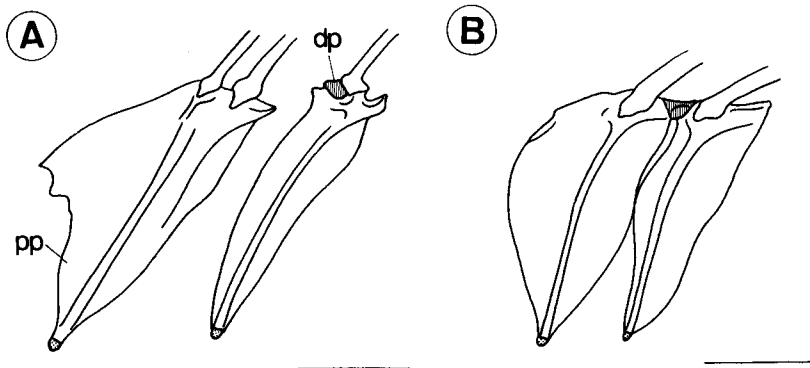

Fig. 32. Lateral aspect of first and second dorsal pterygiophores. A, *Hexagrammos octogrammus*; B, *Zaniolepis frenata*. Bars = 3 mm.

The epipleural ribs are also slender and rod-like, the first two being fastened to the lateral face of their respective neural arches, and the others articulating with the parapophyses or near the base of the pleural ribs.

Median fin supports. The predorsal is a rod-like, non-spine supporting between the cranium and first neural spine. It is present only in *Oxylebius*.

The proximal pterygiophores are large, leaf-like bones, directly supporting the fin rays. They are inserted singly into the dorsal fin interneural spaces (Fig. 30). The first dorsal fin proximal pterygiophore is located between the first and second neural spines (=second interneural space) in *Oxylebius* and *Zaniolepis*, and in the first interneural space in *Ophiodon*. It lies above the first and second neural spines in *Hexagrammos* and *Pleurogrammus*. In addition, the spines on the first pterygiophore number one in *Zaniolepis*, but two in the other genera.

The anal fin proximal pterygiophores are located in the interhaemal spaces (Fig. 31), the first lying in front of the first haemal spine. It is robust in those genera possessing three anal spines (*Oxylebius* and *Zaniolepis*) (Fig. 31A, B). Although most of the other species have only soft rays, *Hexagrammos decagrammus* bears one weak spine on the first anal pterygiophore (Fig. 31C). The distal pterygiophores are tiny bones, each lying near the posterodorsal portion of their respective proximal pterygiophores. They are firmly attached to the proximal pterygiophores in *Oxylebius* and *Zaniolepis*, but are separated in the other genera (Fig. 32). In addition, stays, present behind the posteriormost dorsal and anal pterygiophores in *Oxylebius* and *Zaniolepis*, were absent in the other genera (Fig. 33).

Character argumentation. Seven axial skeleton and median fin support characters were recognized and polarized (Characters 34-40).

I. Apomorphic characters found in "Hexagrammoidei"

Character 34. Absence of predorsal

The presence of a predorsal in *Oxylebius* is regarded as plesiomorphic because

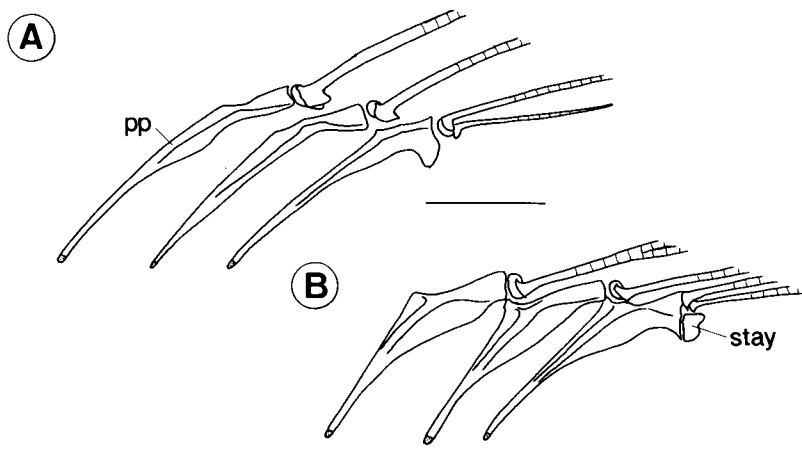

Fig. 33. Lateral aspect of posterior dorsal pterygiophores. A, *Hexagrammos decagrammus*; B, *Oxylebius pictus*. Bars=5 mm.

basal acanthopterygians also possess predorsals. The same primitive condition was observed in the scorpaenoids (*Setarches*, *Pontinus*, *Sebastes*, *Sebastiscus Hozukius*, *Helicolenus*, *Sebastolobus* and *Apistus*) and one platycephaloid (*Bembras*).

Character 35. Spinous dorsal fin proximal and distal pterygiophores separated

This condition, found in *Hexagrammos*, *Pleurogrammus* and *Ophiodon*, is thought to be apomorphic because the proximal and distal pterygiophores of basal acanthopterygians are considered to be attached. The same, derived condition occurs in the cottoids (Yabe, 1985; Kido, 1988; pers. obs.).

Character 36. Dorsal pterygiophores arranged singly in each interneural space

All "hexagrammoids" are characterized by a single dorsal pterygiophore in each interneural space. This condition is thought to be apomorphic because basal acanthopterygians have two pterygiophores in a single interneural space under the spinous dorsal fin at least. The derived condition is also present in one anoplopomatoid (*Anoplopoma*) and all cottoids examined here, confirming the observations of Yabe (1985), Kido (1988) and Kanayama (1991).

Character 37. Absence of anal spines with robust pterygiophores

The well-developed anal spines and robust pterygiophores in *Oxylebius* and *Zaniolepis* are regarded as plesiomorphic, owing to the same condition being present in basal acanthopterygians. Although the number of spines varies in the Scorpaeniformes (see Washington et al., 1984a), the presence of both spines and robust pterygiophores is considered as primitive in the analysis. The derived condition was found in all triglids, platycephaloids, anoplopomatoids and cottoids examined.

Character 38. Absence of stay in dorsal and anal fin supports

This condition was found in *Hexagrammos*, *Pleurogrammus* and *Ophiodon*. Since basal acanthopterygians have the stay in both the dorsal and anal fin supports, its absence is regarded as apomorphic. The stay was also absent in some scorpaenoids (*Minous*, *Inimicus* and *Erispex*), one platycephaloid (*Hoplichthys*), one anoplopomatoid (*Anoplopoma*) and all cottoids examined.

II. Apomorphic characters absent in "Hexagrammoidei", but present in other Scorpaeniformes

Character 39. Plate-like first neural spine

The first neural spine is larger than the second, and plate-like in lateral view, in the platycephaloids (*Rogadius*, *Suggrundus* and *Hoplichthys*). The condition is considered apomorphic because of its absence in basal acanthopterygians.

Character 40. First two neural spines bent forward

This condition was observed in some scorpaenoids as *Paracentropogon*, *Apistus*, *Inimicus*, *Minous* and *Erispex*. It is considered apomorphic since the first two neural spines of basal acanthopterygians are directed dorsally. The condition may be related to the anterior shift of the first and second dorsal pterygiophores because they occupy the region above the two anteriormost neural spines.

III. Other characters

Pattern of dorsal spinous pterygiophore

The predorsal formula (Ahlstrom et al., 1976) varies in the Scorpaeniformes examined here (Table 1). It is believed that the pattern 0//2+1/1/1/ may be the most primitive in the Scorpaeniformes because it is most similar that of berycoids and percoids (Johnson, 1984; pers. obs.). Although some patterns (e.g., 0//2+1/1/

Table 1. Relationships between anterior dorsal pterygiophores and neural spines found in examined scorpaeniforms (formula follows Ahlstrom and Moser., 1976). P, spine-less pterygiophore.

PATTERN	TAXON
0/2/1/1/	<i>Oxylebius</i>
/2/1/1/*	<i>Hexagrammos, Pleurogrammus</i>
2/1/1/1/	<i>Ophiodon</i>
/1/1/1/1/	<i>Zaniolepis</i>
0//2+1/1/1/	<i>Setarches, Pontinus, Sebastes, Sebastiscus, Hozukius, Scorpaena, Helicolenus, Scorpaenopsis, Sebastolobus, Bembras</i>
//2+1/1/1/	<i>Neosebastes, Scorpaenodes, Dendrochirus</i>
2+1//1/1/	<i>Apistus, Inimicus, Paracentropogon</i>
2+1+1//1/1/	<i>Erisphex</i>
1+1//1/1/	<i>Inimicus</i>
//1/1+1/	<i>Chelidonicthys, Peristedion, Rogadius, Suggrundus, Hoplichthys</i>
///1/1+1/	<i>Erileps</i>
////2/1/	<i>Anoplopoma</i>
/////1/	<i>Occella</i>
/2/1/1/	<i>Enophrys, Myoxocephalus, Triglops, Hemilepidotus, Malacocottus, Dasycottus</i>
2/1/1/1/	<i>Blepsias</i>
//1/	<i>Liparis</i>
//P/P/1/	<i>Careproctus</i>
//1/1/	<i>Eumicrotremus</i>

* First pterygiophore is located above first and second neural spines.

1/and //2+1/1/1/) can be apparently easily related to one another, the overall relationships are thought to be complex. Therefore, this character could not be used in the analysis.

10. Caudal skeleton (Figs. 34, 35)

Description. The caudal skeleton is composed of the second and third preural centra, urostyle, hypurals, parhypural, epurals and uroneural.

The second preural centrum is located in front of the urostyle, bearing a short neural spine dorsally and an autogenous haemal spine ventrally. The third preural centrum lies in front of the second, bearing a long neural spine dorsally and an autogenous haemal spine ventrally.

The urostyle is free from the hypural in *Oxylebius*, *Ophiodon*, *Hexagrammos* and *Pleurogrammus*, but fused to the latter in *Zaniolepis*.

The hypural is a plate-like bone, comprising two or three plate-like elements, lying posterior to the urostyle. It is divided into the upper and lower lobes, bearing the upper and lower principal caudal rays, respectively. Although both small and

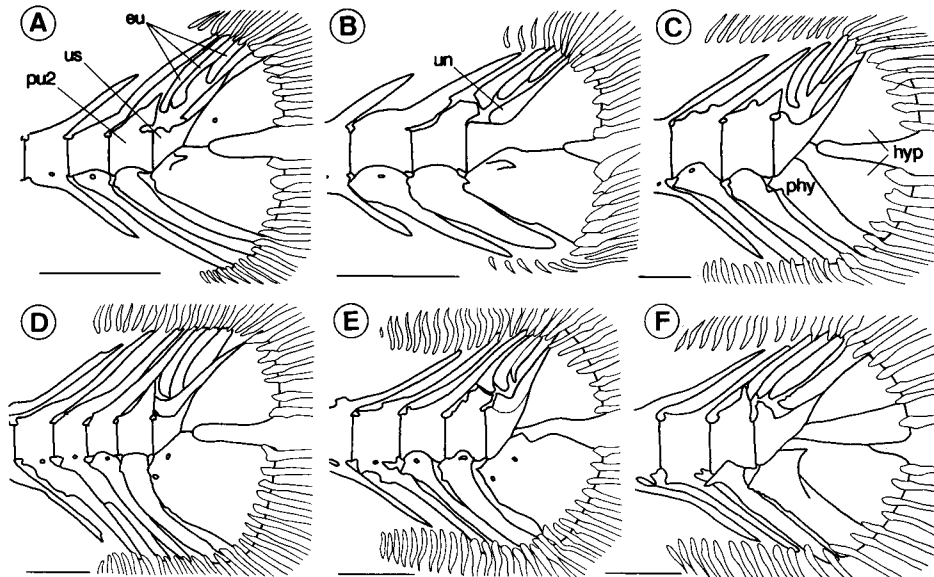

Fig. 34. Lateral aspect of caudal skeleton. A, *Oxylebius pictus*; B, *Zaniolepis frenata*; C, *Ophiodon elongatus*; D, *Hexagrammos decagrammus*; E, *Pleurogrammus azonus*; F, *Anoplopoma fimbria* (Anoplopomatidae). Bars = 5 mm.

large plates are present in the upper lobe of *Oxylebius*, a single large plate is present in the other genera. The upper lobe of the hypural is fused to the urostyle in *Zaniolepis*. The lower lobe comprises a single plate and is free from the urostyle in all genera.

The parhypural is a plate-like bone, lying below the urostyle. It is fused to the lower lobe of the hypurals in *Oxylebius*, *Zaniolepis*, *Hexagrammos* and *Pleurogrammus*. A narrowly based hypurapophysis is present on this bone in *Oxylebius* and *Zaniolepis*.

The epurals are three, rod-like bones, located above the urostyle, the anterior-most being the largest.

The uroneural is a rod-like bone, lying below the epurals and is attached to the urostyle ventrally.

Character argumentation. Two caudal skeleton characters were recognized and polarized (Characters 41, 42).

I. Apomorphic characters found in "Hexagrammoidei"

Character 41. Absence of hypurapophysis

This condition was found in *Hexagrammos*, *Pleurogrammus* and *Ophiodon*. Since basal acanthopterygians have a hypurapophysis, its absence is considered apomorphic. This condition was also found in the aploactinid, *Erisphex*, and all cottoids examined.

II. Apomorphic characters absent in "Hexagrammoidei", but present in other Scorpaeniformes

Character 42. Robust hypurapophysis

The hypurapophysis is robust, having a broad base in the anoplopomatids (Fig. 34F). It is thought to be apomorphic because basal acanthopterygians do not have such condition.

III. Other characters

Fusion of caudal elements (urostyle, hypural, parhypural and haemal spine)

In the Scorpaeniformes, including the "Hexagrammoidei", the condition of the hypural-parhypural complex and related elements varies. It is thought that basal acanthopterygians had five or more hypurals, one parhypural and two autogenous haemal spines on the second and third preural centra, all being free from adjacent bones (Gosline, 1968; Lauder and Liem, 1983; Johnson, 1984). Therefore, the same or similar condition should be primitive in the Scorpaeniformes. Judging from the degree of fusion, the most advanced condition occurs in the peristediid, *Peristedion*, and some cottoids, in which all elements are fused to their neighbors

Table 2. Caudal skeleton patterns. PU, preural centrum; p, parhypural; 1-5, first to fifth hypurals; a, autogenous; f, fused. Formula: + indicates fused; underline indicates fused to urostyle.

PATTERN	FORMULA	haemal spine		TAXON
		PU2	PU3	
A	p. 1. 2. 3. 4. 5	a	a	<i>Setarches</i>
B	p. 1+2. 3. 4. 5	a	a	<i>Bembras</i> *
C	p. 1+2. 3+4. 5	a	a	<i>Sebastiscus, Hozukius, Scorpaena, Scorpaenopsis, Sebastolobus, Scorpaenodes, Dendrochirus, Pontinus, Sebastes, Helicolenus, Neosebastes, Apistus, Suggrundus</i>
D	p+1+2. 3+4. 5	a	a	<i>Rogadius, Oxylebius</i>
E	p. 1+2. 3+4+5	a	a	<i>Ophiodon</i>
F	p. 1+2. 3. 4+5	a	f	<i>Erilepis, Anoplopoma</i>
G	p+1+2. 3+4+5	a	a	<i>Paracentropogon, Hexagrammos, Pleurogrammus</i>
H	p+1+2. 3+4+5	a	f	<i>Liparis</i>
I	p+1+2. <u>3+4</u> . 5	a	a	<i>Inimicus, Chelidonichthys</i>
J	p+1+2. <u>3+4</u> . 5	a	f	<i>Minous, Erisphex</i>
K	p+1+2. <u>3+4+5</u>	a	a	<i>Zaniolepis</i>
L	p+1+2. <u>3+4+5</u>	a	f	<i>Eumicrotremus</i>
M	p+1+2. <u>3+4+5</u>	f	f	<i>Careproctus, Blepsias, Hoplichthys</i>
N	<u>p+1+2+3+4+5</u>	f	f	<i>Enophrys, Myoxocephalus, Triglops, Hemilepidotus, Malacocottus, Dasycottus, Ocella, Peristedion</i>

* Five free hypurals were reported in Fujita (1990).

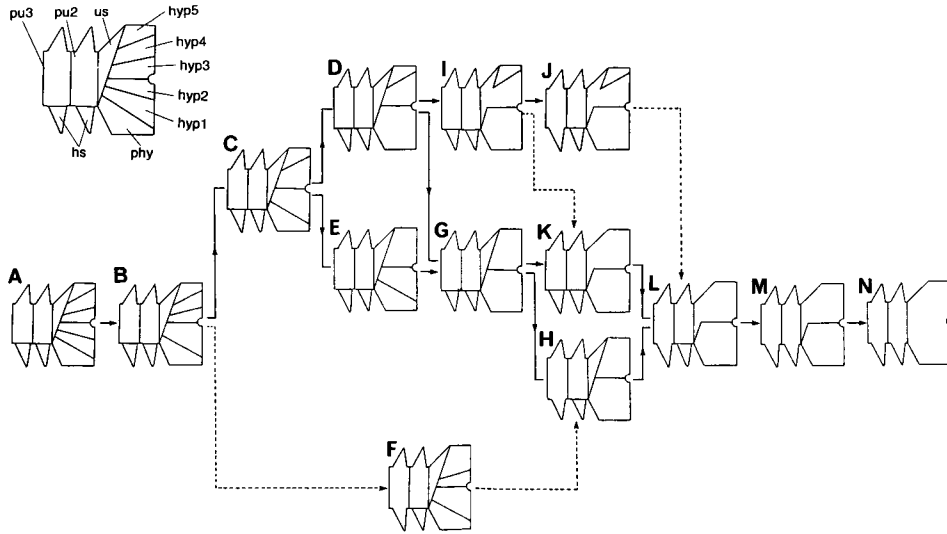

Fig. 35. Relationships of fusing patterns in caudal skeleton.

(Table 2). On the other hand, the most primitive caudal skeleton occurs in a scorpaenid, *Setarches*, which has five hypurals, one parhypural and two autogenous haemal spines. Since there are many intermediate conditions, the relationships of their caudal skeletons, determined using a single polarity (fusion being apomorphic) is clearly complex (Fig. 35). If character reversals have not occurred, it is considered that there are at least seven alternative courses from patterns B to L, suggesting that the advanced conditions (patterns L-N) could have evolved following different paths. Because the homology is therefore questionable, the degree of fusion of caudal elements is not used in the analysis. A character phylogeny was estimated after constructing the interrelationships of the Scorpaeniformes.

VI. Comparative myology

1. Cheek muscle (Figs. 36-38)

Description. The cheek muscle comprises the adductor mandibulae.

The adductor mandibulae is a large muscle, occupying the cheek region. It splits into four sections A1, A2, A3 and Aw, all lacking subsections such as A1 β . The A1 and A2 sections, not being well-separated posteriorly from each other, are located lateral to A3, having originated from the lateral surfaces of the posterior region of the hyomandibular and quadrate, and from the lateral face of the symplectic. They are attached to the medial face of the suborbital stay and the anterior part of the preopercle. The A1 section is inserted anteriorly onto the ligamentum primordium and is connected with the ventral region of the maxillary head via a tendon (Fig. 37). It is well developed anteriorly in *Ophiodon* (Fig. 36A). On the other hand, the A2 section is mainly inserted onto the lateral face of the

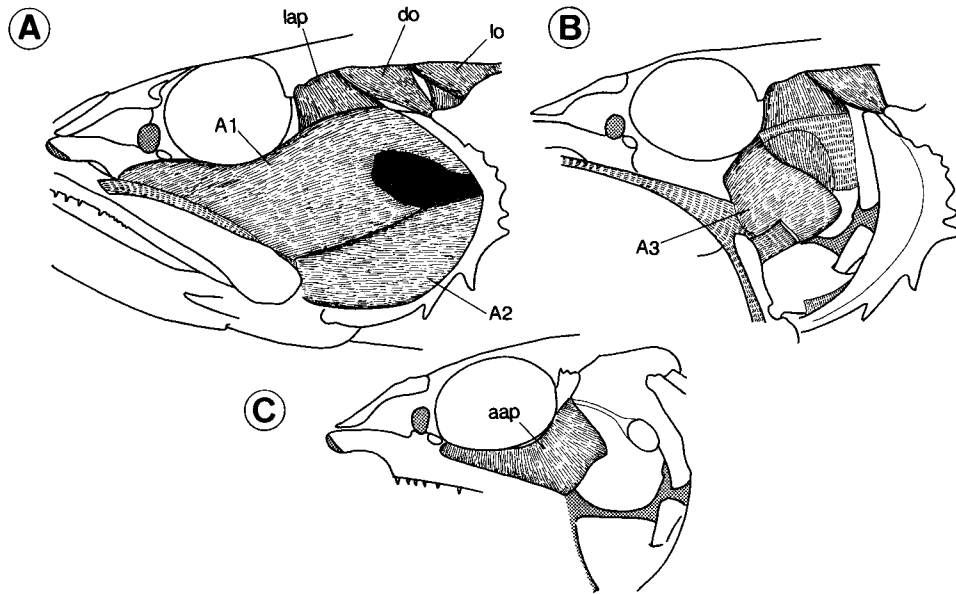

Fig. 36. Lateral aspect of cheek and other cephalic muscles in *Ophiodon elongatus*. A, superficial view; B, lateral view after removing A1 and A2; C, lateral view after removing A3 and lap.

anguloarticular. It clearly branches into two parts anteriorly in *Hexagrammos*, the dorsal part being attached to the ligamentum primordium and the other to the anguloarticular (Fig. 38B). The A3 section is located on the lateral surfaces of the hyomandibular, metapterygoid and quadrate. The Aw section is located on the medial face of the lower jaw (Fig. 37). It is joined posteriorly to the medial face of the quadrate by strong connective tissue.

Character argumentation. Two cheek muscle characters were recognized and polarized (Characters 43, 44).

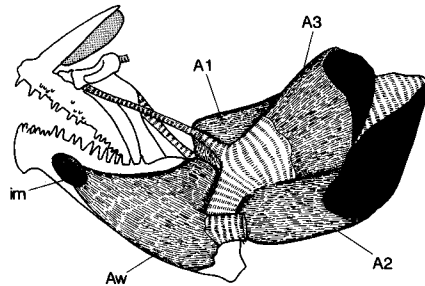

Fig. 37. Medial aspect of cheek muscle and both jaws in *Hexagrammos stelleri*. Bar = 10 mm.

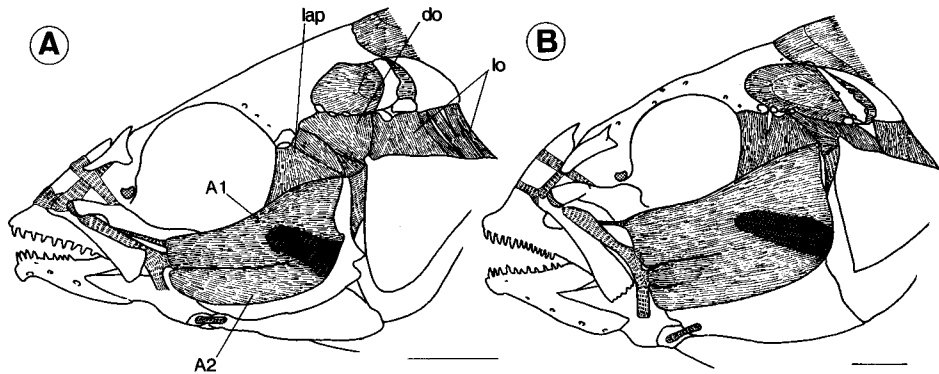

Fig. 38. Lateral aspect of cheek and other cephalic muscles. A, *Oxylebius pictus*; B, *Hexagrammos decagrammus*. Bars=5 mm.

I. Apomorphic characters found in "Hexagrammoidei"

Character 43. A2 section branched anteriorly

This condition was found only in *Hexagrammos* among the Scorpaeniformes examined here (Fig. 38B; hexagrammid type of Yabe, 1985). Since basal acanthopterygians do not have a branched A2 section, the condition is regarded as apomorphic.

II. Apomorphic characters absent in "Hexagrammoidei", but present in other Scorpaeniformes

Character 44. A1 section divided into inner and outer subsections

This condition was observed in the cyclopterids (*Liparis*, *Careproctus* and *Eumicrotremus*), having already been reported for that family (Yabe, 1985; Mandrytza, 1990). It is considered apomorphic because basal acanthopterygians lack subsections of the A1 section.

III. Other characters

None.

2. Cephalic muscles between neurocranium and suspensorium-opercular bones (Figs. 36, 38)

Description. Cephalic muscles in this region comprise the adductor arcus palatini, levator arcus palatini, dilatator operculi and levator operculi.

The adductor arcus palatini occupies the space between the ventral region of the cranium and the dorsal margin of the suspensorium (Fig. 36C), connecting the entopterygoid and metapterygoid with the parasphenoid.

The levator arcus palatini is a lozenge-shaped muscle, lying posterior to the orbit and interconnecting the cranium and suspensorium. It originates from the sphenotic and is inserted onto the metapterygoid. Some fibers of this muscle are attached to the medial face of the suspensorium through a metapterygoid foramen.

The dilatator operculi originates from the ventrolateral area of the sphenotic and is inserted onto the head of the opercle.

The levator operculi is a thin muscle, interconnecting the neurocranium and opercle. It originates from the sphenotic and ventral margin of the posttemporal, and is inserted into the groove on the medial side of the opercle.

Character argumentation.

No characters in this section.

3. Ventral muscles of head (Figs. 39, 40)

Description. The ventral muscles of the head comprise the intermandibularis, protractor hyoidei, hyohyoidei abductores and hyohyoidei adductores. A hyohyoideus inferioris is absent.

The intermandibularis is a single muscle, lying between the left and right dentaries.

The protractor hyoidei is a robust muscle, originating from the anteromedial part of the dentary, either directly or via connective tissue, and being inserted onto the lateral face of the ceratohyal near the base of the third branchiostegal ray.

The hyohyoidei abductores are split into two sections, section 1 originating from the anteroventral region of the ceratohyal and being inserted onto the proximal portion of each branchiostegal ray, and section 2 interconnecting the medial and distal portions of the first branchiostegal ray. The left and right elements meet in the ventral midline. Anteriorly, section 2 is connected with the ventral hypohyal via connective tissue.

The hyohyoidei adductores are sheet-like muscles, connecting the branchiostegal rays to the subopercle.

Character-argumentation. Although the "Hexagrammoidei" dose not have a hyohyoideus inferioris, this muscle is present in some scorpaeniforms (Yabe, 1985),

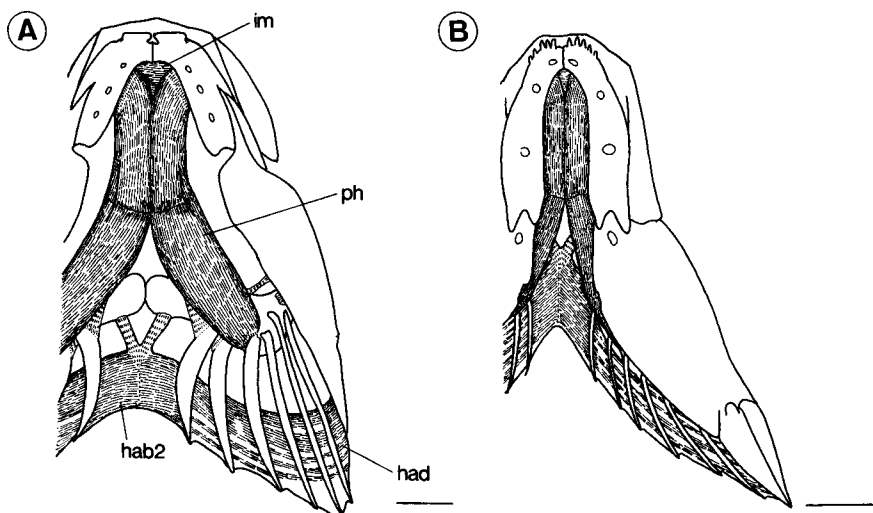

Fig. 39. Ventral aspect of ventral muscles of head. A, *Hexagrammos octogrammus*; B, *Zaniolepis frenata*. Bars = 5 mm.

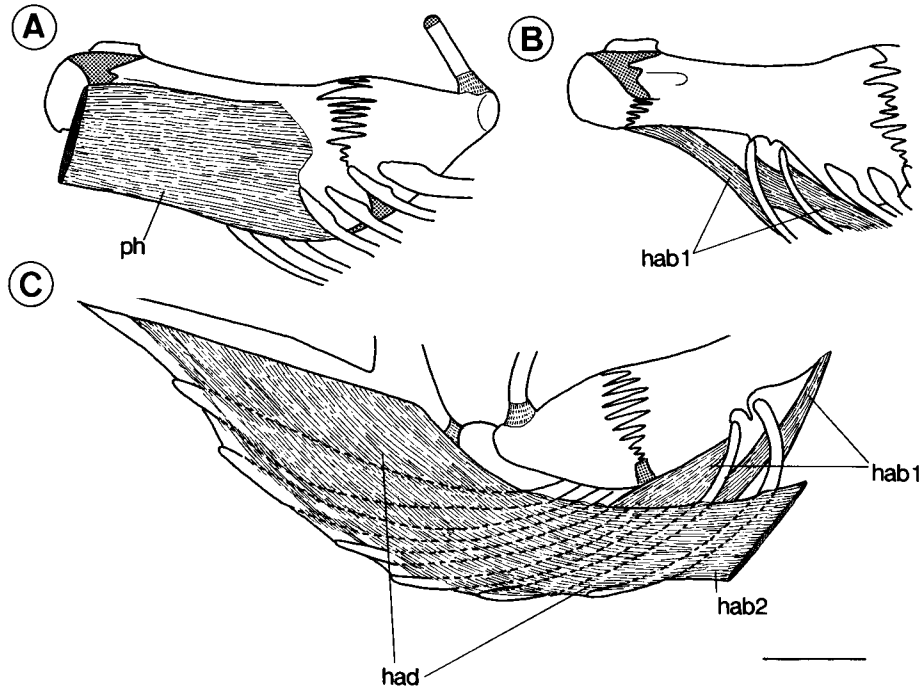

Fig. 40. Lateral (A and B) and medial (C) aspects of ventral muscles of head in *Hexagrammos stelleri*. A and B, hyoid regions; C, hyoid-opercular region. Bar = 5 mm.

being found here in the scorpaenoids (*Minous* and *Peristedion*), platycephaloids, anoplopomatoids and cyclopterids. According to Yabe (1985), *Minous* and *Peristedion* are classified as type D-1, the platycephaloids as type B, the anoplopomatoids as type C and the cyclopterids as type D-2. Since the berycoids and percoids examined here did not have the muscle, its presence may be apomorphic. However, the relationships and homology among the above types are uncertain because of the large morphological gaps between the muscle types. Because the ancestral condition could not be determined, the hyohyoides inferioris character could not be used in the analysis.

4. Branchial muscles (Fig. 41)

Description. The branchial muscles include the levator externus, levator internus, levator posterior, transversus dorsalis, obliquus dorsalis, retractor dorsalis, rectus communis, pharyngoclavicularis, rectus ventralis, obliquus ventralis, transversus ventralis, sphincter oesophagi and obliquus posterior. The muscles associated with the upper branchial arches are the levator externus, levator internus, levator posterior, transversus dorsalis and obliquus dorsalis.

The levator externus consists of four elements, connecting the ventral face of the cranium with the epibranchials. They originate just below the cranial groove for

the hyomandibular articulation, the first to fourth elements being inserted onto the first to fourth epibranchials, respectively.

The levator internus consists of two elements, separated by the transversus dorsalis anterior. Their origin is near that of the levator externus. The anterior element is inserted onto the anterior region of the second pharyngobranchial and the posterior one onto the lateral region of the third pharyngobranchial.

The levator posterior originates from the ventral side of the intercalar and exoccipital, and is inserted onto the fourth epibranchial, just lateral to the fourth levator externus.

The transversus dorsalis anterior and posterior interconnect the right and left elements of the second to last epibranchials.

The obliquus dorsalis is located between the third pharyngobranchial and the third to fourth epibranchials. Anteriorly, it lies below the transversus dorsalis anterior and transversus dorsalis posterior.

The retractor dorsalis originates from the posterior region of the third and fourth pharyngobranchials, and is inserted onto the ventrolateral face of the anterior abdominal vertebrae.

The muscles serving the lower branchial arches comprise the rectus communis, pharyngoclavicularis, rectus ventralis, obliquus ventralis and transversus ventralis.

The rectus communis originates from the lateral surface of the urohyal and is inserted onto the fifth ceratobranchial.

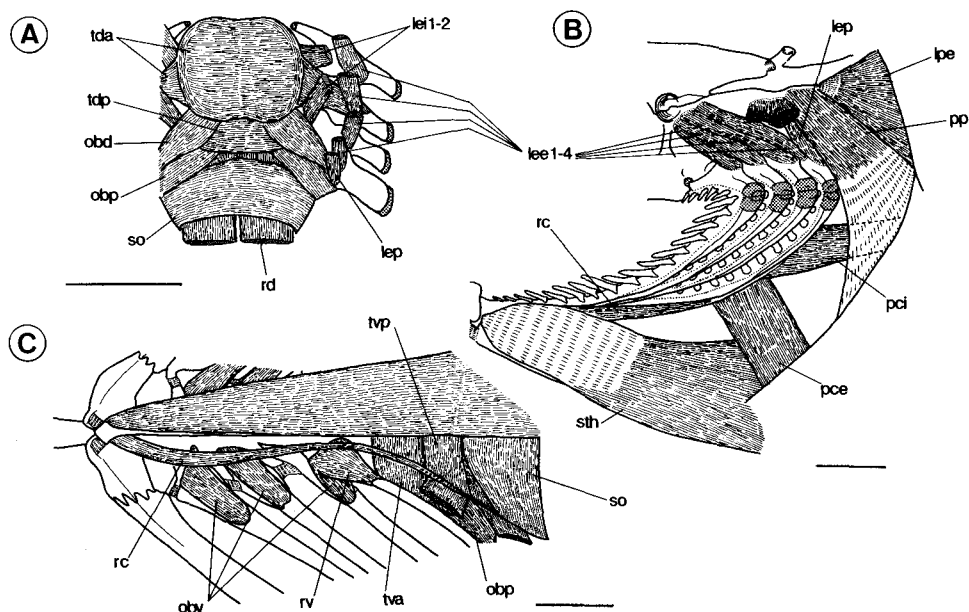

Fig. 41. Branchial muscles of *Pleurogrammus azonus*. A, dorsal view of muscles serving upper branchial arches; B, lateral view; C, ventral view of muscles serving lower branchial arches. Bars=5 mm.

The pharyngoclavicularis connects the fifth ceratobranchial with the cleithrum. It consists of two sheet-like muscles, the pharyngoclavicularis externus and internus. The posterior part of internus passes medially to the protractor pectoralis.

The rectus ventralis is a single muscle, lying between the anterior regions of the third hypobranchial and the fourth ceratobranchial.

The obliquus ventralis comprises three muscles, interconnecting the first to third hypobranchials with the first to third ceratobranchials, respectively.

The transversus ventralis comprises anterior and posterior elements, the former interconnecting the fourth ceratobranchials and the latter the fifth ceratobranchials.

The remaining muscles, including the sphincter oesophagi and obliquus posterior are associated with the upper and lower parts of gill arches.

The sphincter oesophagi encircles the oesophagus, arising ventrally from the dorsal rim of the fifth ceratobranchial and dorsally from the posterior margin of the fourth epibranchial.

The obliquus posterior links the ceratobranchial to the fourth epibranchial.

Character argumentation. One branchial muscle character was recognized and polarized (Character 45).

I. Apomorphic characters found in "Hexagrammoidei"

None.

II. Apomorphic characters absent in "Hexagrammoidei", but present in other Scorpaeniformes

Character 45. Absence of third levator externus

This condition was observed in some of the scorpaenoids (*Neosebastes*, *Scorpaenodes*, *Inimicus* and *Erisphex*) and all of the cottoids examined. Since basal acanthopterygians have a third levator externus, its absence is considered a derived condition.

III. Other characters

None.

5. Pectoral fin muscles (Figs. 41-43)

Description. Muscles serving the pectoral girdle comprise the abductor superficialis, abductor profundus, arrector ventralis, adductor superficialis, adductor profundus, arrector dorsalis, coracoradialis, levator pectoralis, protractor pectoralis and sternohyoideus.

The abductor superficialis is a superficial division of the pectoral muscles. It originates from the lateral flange of the cleithrum and is inserted onto all fin ray bases except the uppermost. The fiber is reduced to thin, transparent tissue before reaching the fin rays.

The abductor profundus is a medial division of the lateral muscles, lying between the abductor superficialis and pectoral girdle. It primarily originates from the coracoid and is inserted onto all fin ray bases except the uppermost.

The arrector ventralis is located just above the abductor profundus. It arises from the cleithrum and is attached to the base of the uppermost ray. The muscle is well developed in *Zaniolepis* and *Oxylebius*, but reduced in the other genera (Fig. 43).

The adductor superficialis is a dorsomedial division of the pectoral muscles. It

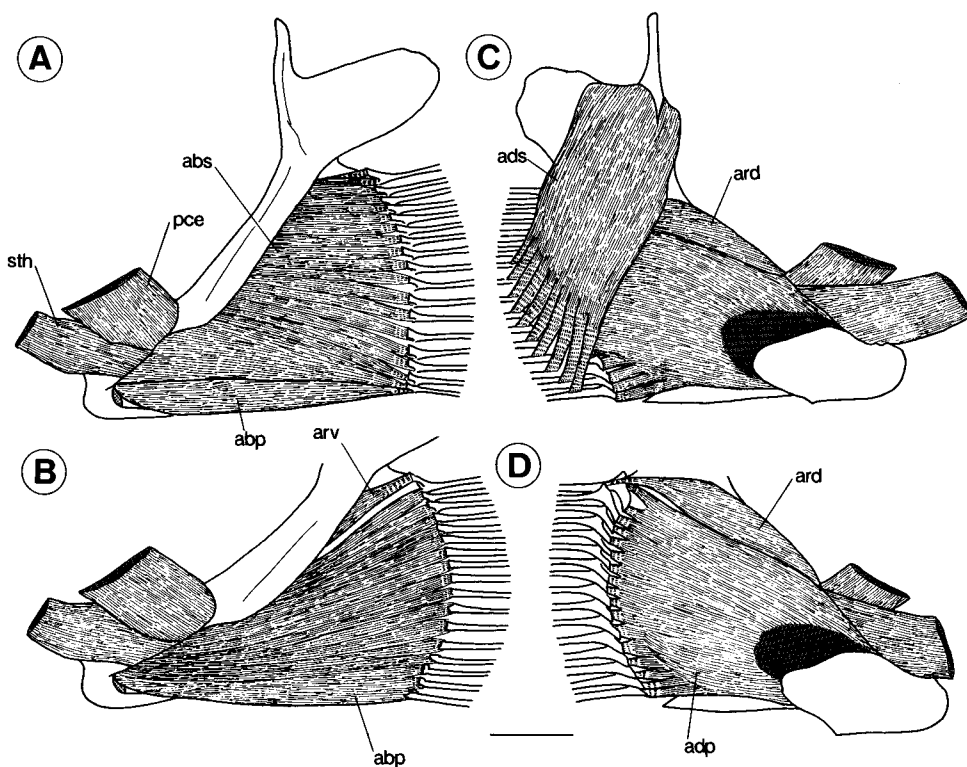

Fig. 42. Lateral (A and B) and medial (C and D) aspects of pectoral muscles in *Ophiodon elongatus*. A and C, superficial views; B, after removing abs; D, after removing ads. Bar = 10 mm.

arises from the dorsomedial face of the cleithrum and is attached to all fin ray bases, except the uppermost.

The adductor profundus, originating from the coracoid and scapula and being inserted onto all fin ray bases, broadly occupies the medial side of pectoral girdle.

The arrector dorsalis is located just above the adductor profundus, arising from the cleithrum and being attached to the second fin ray base.

The coracoradialis is a poorly developed muscle, lying between the fourth actinost and the posterior process of the coracoid.

The levator pectoralis originates from the posteroventral region of the cranium, including the pterotic, intercalar and exoccipital, and is inserted onto the supra-cleithrum.

The protractor pectoralis connects the cranium and cleithrum, having originated from the pterotic and being inserted onto the cleithrum. Posteroventrally, it is transformed into thin transparent tissue (Fig. 41B).

The sternohyoideus is a robust muscle occupying the throat. It originates from the lateral face of the urohyal and is inserted onto the cleithrum. Some fibers of

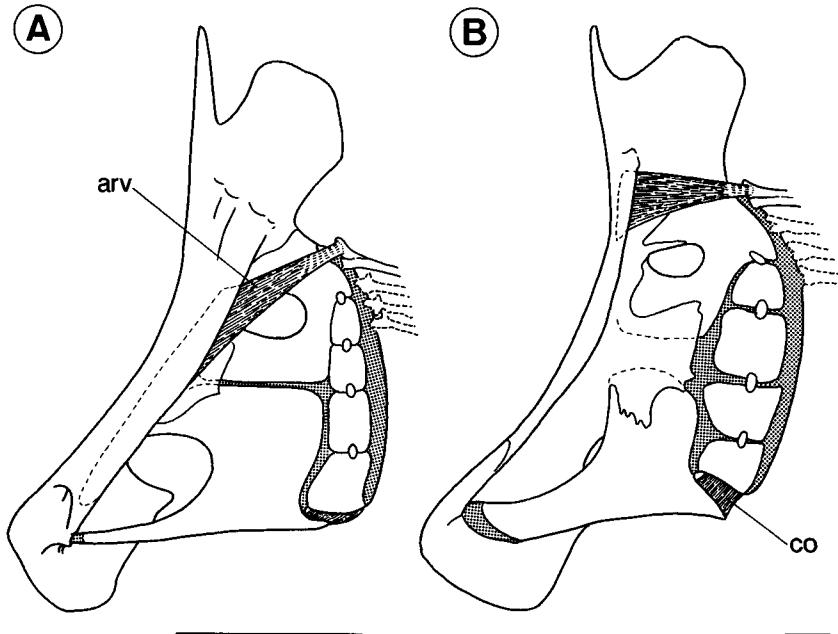

Fig. 43. Lateral aspect of arrector ventralis and coracoradialis. A, *Zaniolepis latipinnis*; B, *Pleurogrammus azonus*. Bars = 3 mm.

this muscle are fused with the body muscles (Fig. 41B).

Character argumentation. One pectoral muscle character was recognized and polarized (Character 46).

I. Apomorphic characters found in "Hexagrammoidei"

Character 46. Reduced arrector ventralis

This condition was found in *Hexagrammos*, *Pleurogrammus* and *Ophiodon*, and was also present in some scorpaenoids (*Neosebastes*, *Erisphex* and *Peristedion*) and all of the cottoids examined. It is considered apomorphic because basal acanthopterygians have a well developed arrector ventralis.

II. Apomorphic characters absent in "Hexagrammoidei", but present in other Scorpaeniformes

None.

III. Other characters

None.

6. Pelvic fin muscles (Fig. 44)

Description. The muscles of the pelvic fin comprise the adductor superficialis pelvius, adductor profundus pelvius, arrector dorsalis pelvius, extensor proprius, abductor superficialis pelvius, abductor profundus pelvius and arrector ventralis pelvius.

The adductor superficialis pelvius is a dorsal division of the pelvic muscles (Fig. 44A, C), lying on the adductor profundus pelvius. It is connected to the

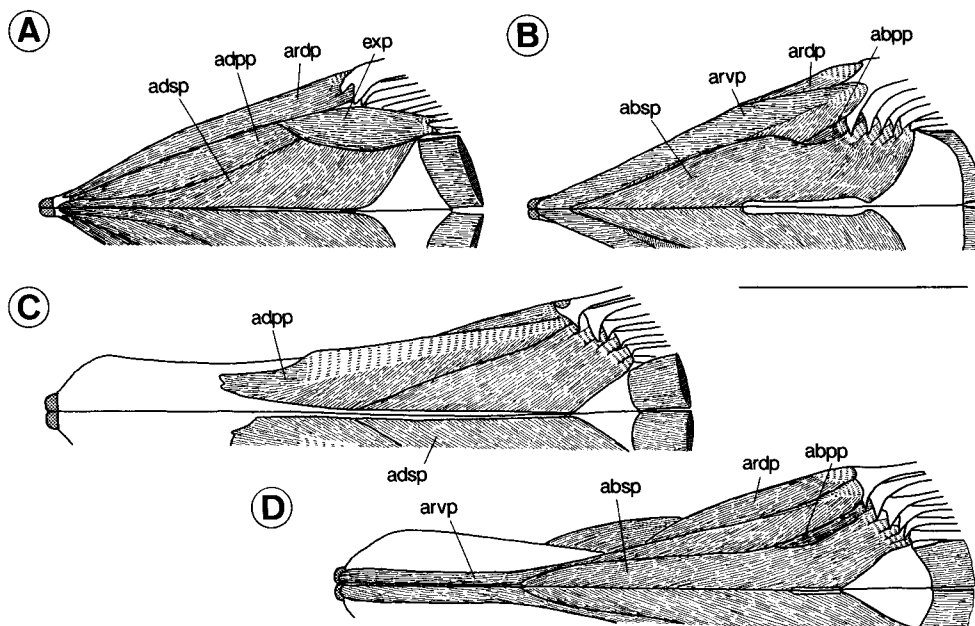

Fig. 44. Dorsal (A and C) and ventral (B and D) aspects of pelvic muscles. A and B, *Zaniolepis latipinnis*; C and D, *Pleurogrammus azonus*. Bars=5 mm.

spine and all soft ray bases.

The adductor profundus pelvici originates from the dorsal face of the pelvic girdle and is inserted onto the spine and all soft ray bases.

The arrector dorsalis pelvici arises from the lateral surface of the pelvic girdle and is inserted onto the spine and all soft ray bases.

The extensor proprius is present in *Zaniolepis*, *Oxylebius* and *Ophiodon*, lying on the adductor superficialis pelvici and adductor profundus pelvici (Fig. 44A). It originates from a thin fascia covering the dorsal muscle division and is inserted onto the dorsal surface of the soft ray bases.

The abductor superficialis pelvici is a ventral division of the pelvic muscles (Fig. 44B, D). It originates from the inner surface of the pelvic girdle and is inserted onto all soft ray bases. The muscle is also attached posteriorly to the subpelvic process.

The abductor profundus pelvici lies medial to the abductor superficialis pelvici. It originates from the medial region of the pelvic girdle and is inserted onto all soft ray bases.

The arrector ventralis pelvici arises from the ventrolateral region of the pelvic girdle, and is inserted onto the ventrolateral face of the pelvic spine base (Fig. 44B, D).

Character argumentation. One pelvic fin muscle character was recognized and polarized (Character 47).

I. Apomorphic characters found in "Hexagrammoidei"

Character 47. Absence of extensor proprius

This condition was found in *Hexagrammos* and *Pleurogrammus*, and regarded as derived owing to its presence in basal acanthopterygians. The muscle was absent in the aploactinid, *Erisphex*, and all cottoids examined.

II. Apomorphic characters absent in "Hexagrammoidei", but present in other Scorpaeniformes

None.

III. Other characters

None.

7. Muscles associated with median fins (Fig. 45)

Three muscle categories (erector, depressor and inclinor) occur in both the dorsal and anal fins, being attached to the fin ray bases by aponeuroses. The carinal muscles connect the dorsal and anal fin supports to the other skeletal parts.

Muscles of dorsal fin. The dorsal fin muscles include the erectores dorsales, depressores dorsales and inclinatores dorsales.

The erectores dorsales originate from the lateral faces of the proximal dorsal pterygiophores and are inserted anteromedially onto the bases of the dorsal fin rays.

The depressores dorsales arise from the posterolateral faces of the proximal dorsal pterygiophores and are attached to the lateral region of the dorsal fin ray bases.

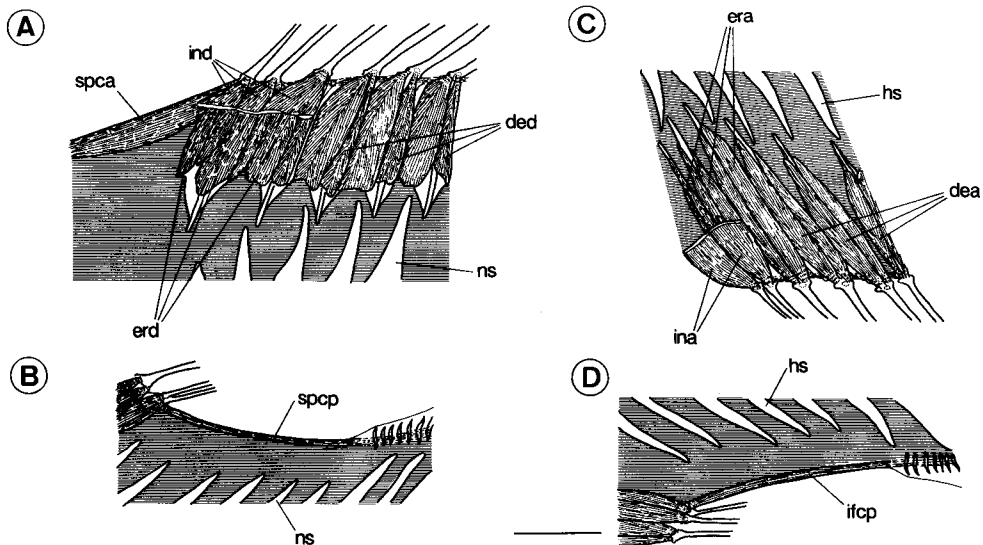

Fig. 45. Lateral aspect of median fin muscles in *Hexagrammos octogrammus*. A, dorsal fin (anterior part); B, dorsal fin (posterior part); C, anal fin (anterior part); D, anal fin (posterior part). Bar = 5 mm.

The inclinatores dorsales are superficial elements lying on the epaxialis, having originated from the fascia between the skin and epaxialis.

Muscles of anal fin. The anal fin muscles comprise the erectores anales, depressores anales and inclinatores anales.

The origin of erectores anales is located on the anterolateral faces of the anal fin proximal pterygiophores.

The depressores anales originate from the posterolateral region of the anal fin proximal pterygiophores and are inserted onto the lateral regions of the anal fin ray bases.

The inclinatores anales are superficial elements, each muscle arising from the fascia between the skin and hypaxialis. They are inserted onto the lateral regions of the anal fin ray bases.

Carinal muscles. The carinal muscles, paired muscles lying on the dorsal and ventral midlines include five elements: the supracarinalis anterior, supracarinalis posterior, infracarinalis posterior, infracarinalis anterior and infracarinalis medius. Some fibers of the infracarinalis anterior and posterior are fused to the body muscles, but those of the other muscles are independent (Fig. 45A, B and D).

The supracarinalis anterior lies between the anterior parts of the left and right epaxial muscles, connecting the anteriormost dorsal fin proximal pterygiophore with the supraoccipital.

The supracarinalis posterior is a cord-like muscle, interconnecting the last dorsal pterygiophore with the procurrent caudal fin rays (Fig. 45B).

The infracarinalis posterior is a cord-like muscle, lying between the last anal pterygiophore and the procurrent caudal fin rays (Fig. 45D).

Character argumentation.

No characters in this section.

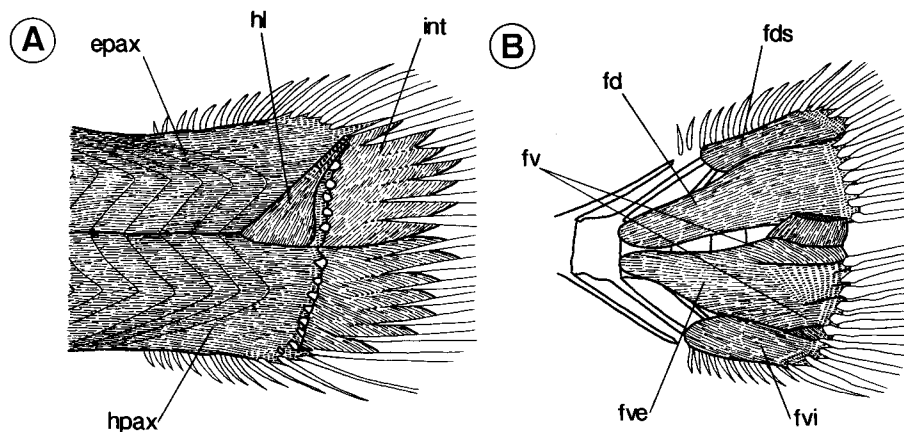

Fig. 46. Lateral aspect of caudal fin muscles in *Ophiodon elongatus*. A, superficial view; B, after removing epax and hpax. Bar=10 mm.

8. Caudal fin muscles (Fig. 46)

Description. The muscles associated with the caudal skeleton are the interradialis, hypochordal longitudinalis, flexor dorsalis superior, flexor dorsalis, flexor ventralis, flexor ventralis externus and flexor ventralis inferior. Although two body muscles (=epaxialis and hypaxialis) support the caudal-fin rays, they are described in the next section. An adductor dorsalis is absent.

The interradialis is located between the principal caudal fin rays (Fig. 46A). It splits into dorsal and ventral sections, lying in the dorsal and ventral lobes of caudal fin, respectively.

The hypochordal longitudinalis is a small, triangular muscle (Fig. 46A), originating from the upper region of the lower hypural and transforming into the transparent connective tissue distally, before being inserted onto some upper dorsal lobe fin rays.

The flexor dorsalis originates from the dorsal half of preural centrum 2 and its neural spine, and is inserted onto the bases of the principal dorsal lobe fin rays (Fig. 46B).

The flexor dorsalis superior originates from the distal portions of both the epurals and neural spines. Some posterior fibers are inserted onto the bases of the uppermost principal ray and posterior procurrent rays of the dorsal lobe.

The flexor ventralis originates from the second preural centrum and its haemal spine, and is inserted onto the bases of the principal and posterior procurrent ventral lobe rays (Fig. 46B).

The flexor ventralis inferior is located ventrally to the flexor ventralis, being inserted onto the bases of a few procurrent ventral lobe rays.

The flexor ventralis externus arises from the lateral surfaces of the third to fifth preural centra, the anterior part being slightly fused to the flexor ventralis. The former is inserted onto the bases of three or four upper principal rays on the lower lobe by transparent connective tissue.

Character argumentation. One caudal fin muscle character was recognized and polarized (Character 48).

I. Apomorphic characters found in "Hexagrammoidei"

None.

II. Apomorphic characters absent in "Hexagrammoidei", but present in other Scorpaeniformes

Character 48. Presence of adductor dorsalis

An adductor dorsalis has been reported in some scorpaeniforms (Rybachuk, 1976; Yabe, 1985). It was present in all of the scorpaenids examined and in one platycephalid (*Bembras*). It is considered apomorphic because of its absence in basal acanthopterygians.

III. Other characters

None.

9. Body muscles (Fig. 47)

Description. The body muscles comprise many myomeres which are separated from their neighbors by myocommata. They are divided into two major divisions: the epaxialis and hypaxialis.

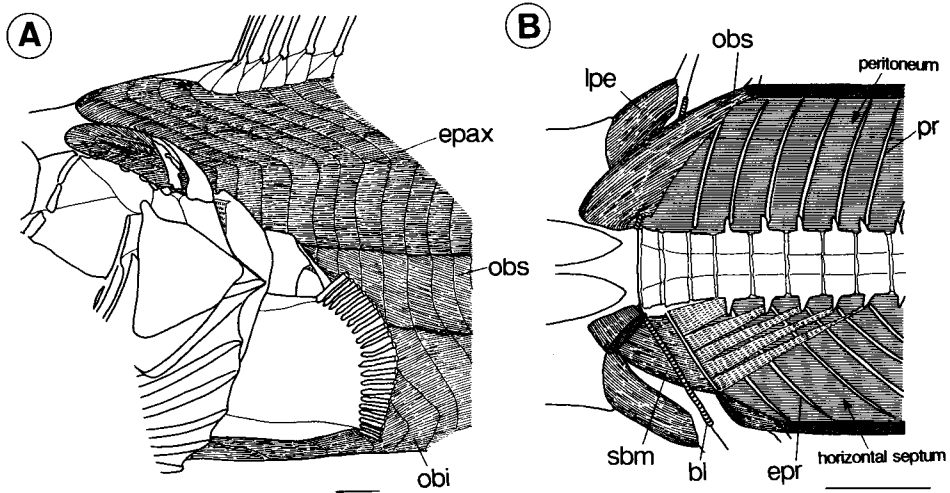

Fig. 47. Lateral (A) and ventral (B) aspects of body muscles in two species of *Hexagrammos*. A, *H. otaki*; B, *H. octogrammus* (after removing obi). Bars=5 mm.

Although each "hexagrammoid" lacks a swimbladder, as do some other scorpaeniforms, they retain muscles which were probably associated with a swimbladder (Yabe, 1985). These are described below as the "swimbladder" muscle.

Main body muscle. The epaxialis is the large, dorsal component of the body muscles (Fig. 47A), attached to the posterodorsal surface of the neurocranium anteriorly and to the bases of the caudal fin upper lobe rays posteriorly. The fibers are connected to the posterodorsal regions of the supracleithrum and cleithrum, and medially to the vertebral centra and neural arches and spines between the neurocranium and caudal skeleton.

The hypaxialis is the ventral component of the body muscles, which is separated from the epaxialis by the horizontal septum. It comprises two subdivisions: the obliquus superioris and obliquus inferioris (Fig. 47A). The obliquus superioris, lying just below the horizontal septum, arises from the posterolateral region of the neurocranium and is attached to the cleithrum and postcleithrum. The obliquus posterior originates from the posterior face of the cleithrum and coracoid, and is anteriorly fused to the sternohyoideus. It lies ventrally to the obliquus superior, to which it is fused posteriorly.

"Swimbladder" muscle (sensu Yabe, 1985). The "swimbladder" muscle is located between the epaxialis and obliquus superioris, having originated from the intercalar and nearby area on the neurocranium (Fig. 47B). It is connected to the anterolateral parts of the parapophyses by thin aponeuroses, following its intermediate attachment to the second epipleural. Some fibers are attached to the pectoral girdle in *Zaniolepis*.

Character argumentation. Swimbladder muscle of the scorpaeniforms has been surveyed by many investigators (e.g., Matsubara, 1943a; Yabe, 1985). According to Hallacher (1974), *Zaniolepis* is distinguishable from *Hexagrammos* in having a

cranioclavical muscle, which is also found in the Cottoidei. However, the different condition of *Zaniolepis* from the cottoids was reported by Yabe (1985: Fig. 49B) and supported by present observation. Although Yabe (1985) noted that some fibers of this muscle were attached to the cleithrum in the zaniolepidids and anoplopomatids, a similar condition has been found in some scorpaenids (Hallacher, 1974; pers. obs.). This character was not used in the analysis because varying degrees of cleithral attachment occur within the genus *Sebastes* (Hallacher, 1974).

VII. Comparative cranial nervous system

Although ten nerves (I-X) occur in the cranium, only the trigemino-facial nerves (V and VII), which have complex distributions on the head (Freihofer, 1963), are described and discussed in this section. They arise from the trigemino-facialis complex located near the trigeminal and facial foramina of the prootic.

1. Trigeminal nerves (V) (Figs. 48, 49)

Description. The trigeminal nerves comprise both cutaneous and vicermotor fibers, and have the following four main rami: the ramus ophthalmicus superficialis trigeminus, ramus maxillaris trigeminus, ramus mandibularis trigeminus and ramus

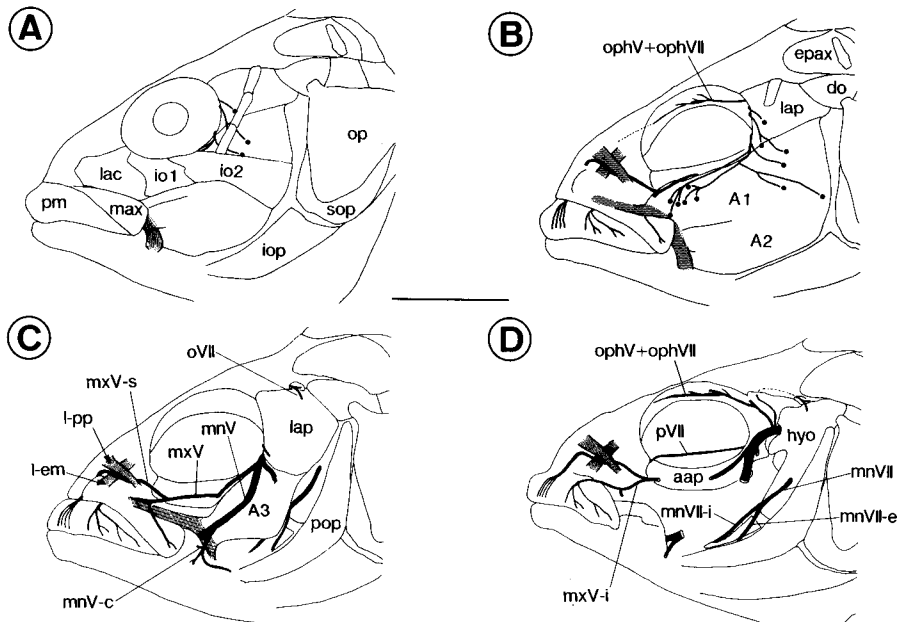

Fig. 48. Lateral aspect of head in *Hexagrammos agrammus*. A, after removing skin; B, after removing eye ball, lachrymal and first to fourth infraorbital bones; C, after removing A1-2; D, after removing A3 and lap. Solid circle, branch of ramus buccalis facialis. Bar = 10 mm.

opercularis trigeminus.

The ramus ophthalmicus superficialis trigeminus passes anteriorly along the ventral surface of the frontal (Fig. 48B, D). Comprising only cutaneous fibers, it is accompanied by the ramus ophthalmicus superficialis, coursing forward dorsally to the eye in the rear of the orbital cavity.

The ramus maxillaris trigeminus initially belongs to the truncus infraorbitalis. After entering the orbital cavity for some distance, the branch runs parallel to the ramus mandibularis trigeminus, before passing anteriorly along the dorsal surface of the adductor arcus palatini (Fig. 48C). In the anteroventral region of the orbital cavity, it splits into dorsal and ventral ramuli: the ramulus maxillaris superioris trigeminus and ramulus maxillaris inferioris trigeminus (Fig. 48C, D). The ramulus maxillaris superioris trigeminus continues anterodorsally lateral to the palatine and passes between the palato-premaxillary and ethmo-maxillary ligaments on its way to the lateral face of the ascending process of the premaxillary in *Hexagrammos*, *Pleurogrammus*, *Ophiodon* and *Zaniolepis* (Fig. 48C). However, it passes laterally to both ligaments in *Oxylebius*. This ramulus eventually innervates the anterior portion of the upper jaw lip. On the other hand, the ramulus maxillaris inferioris trigeminus passes anteroventrally toward the upper jaw, splitting into upper and lower branches. The upper branch passes under the maxillary and ultimately innervates the posterior region of the premaxillary. The lower branch ends on the posterolateral region of the maxillary.

The ramus mandibularis trigeminus is thick, running downward between adductor mandibulae sections 1 and 2 (Fig. 48C). A short, initial branch innervates the adductor mandibulae posteroventrally, with the main nerve coursing anteroventrally lateral to the adductor mandibulae A1 section and continuing to the lower

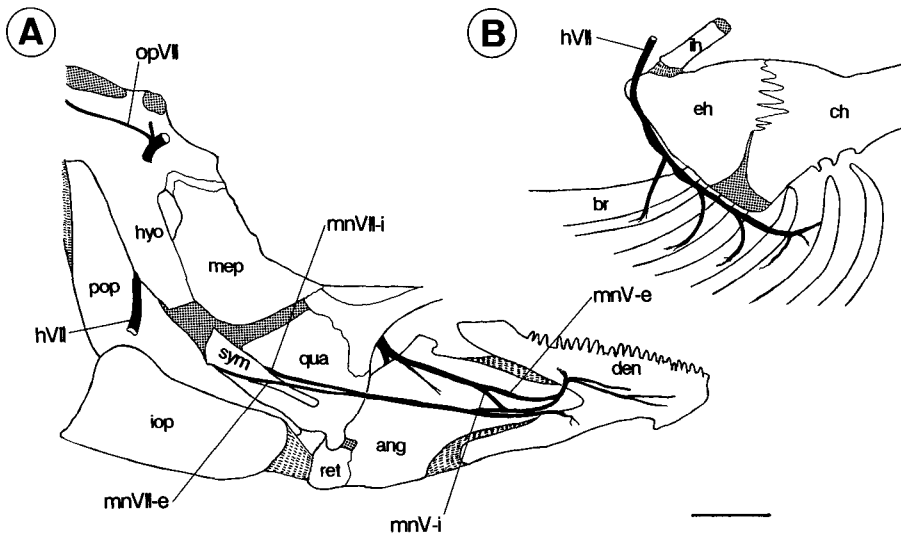

Fig. 49. Medial aspect of suspensorium and lower jaw (A) and hyoid arch (B) in *Hexagrammos agrammus*. All muscles removed. Bar=5 mm.

jaw. Before reaching the anguloarticular, it gives rise to the ramulus mandibularis cutaneus trigeminus, which innervates the anguloarticular near the origin of the ligamentum primordium and the skin of the anteroventral area of the cheek (Fig. 48D). The main part of ramus mandibularis trigeminus enters the medial side of the lower jaw, crossing the ascending process of the anguloarticular. Some fibers innervate the adductor mandibulae Aw section. In the middle region of lower jaw, the ramus splits into two ramuli: the ramulus mandibularis externus trigeminus and ramulus mandibularis internus trigeminus (Fig. 49A). The former primarily passes anteriorly through the gap between the dentary and anguloarticular, to finally innervate the skin of the lower jaw. The latter quickly joins with two facial nerves, such as the ramulus mandibularis externus facialis and ramulus mandibularis internus facialis, to innervate the intermandibularis, protractor hyoidei and skin covering the lower jaw.

The ramus opercularis trigeminus is thin, being located medially to the hyomandibular. It splits into two ramuli, innervating the levator arcus palatini and dilatator operculi, respectively.

Character argumentation. A single variation, being the relationship of ramulus maxillaris superioris trigeminus with the palato-premaxillary and ethmo-maxillary ligaments, was observed. The relationship varied in the berycoids and percoids examined, and the common condition of basal acanthopterygians could not be determined. Therefore, the character was not used in the analysis.

2. Facial nerves (VII) (Figs. 48-50)

Description. The facial nerves comprise the communis (connecting with taste buds), acousticolateralis (lateral line organs) and visceromotor (muscles of jaws) components, and sometimes possess cutaneous fibers. The nerves comprise eight rami: the ramus ophthalmicus superficialis facialis, ramus oticus, ramus buccalis facialis, ramus mandibularis facialis, ramus hyoideus, ramus opercularis facialis, ramus palatinus and ramus lateralis accessorius facialis (=RLA). The ramus buccalis accessorius facialis is absent (reduced?) in the "Hexagrammoidei".

The ramus ophthalmicus superficialis facialis courses anteriorly along the ventral surface of the sphenotic and frontal, accompanying the ramus ophthalmicus superficialis trigeminus (Fig. 48B). It gives off some small branches to the supraorbital canal on the frontal, and finally ends at the medial face of the nasal.

The ramus oticus passes dorsolaterally over the surface of the orbital cavity, to enter the sensory canal of the sphenotic. Thereafter, it runs posteriorly, giving rise to a branch innervating the dermosphenotic (Fig. 48C).

The ramus buccalis facialis is divided into several branches, which are distributed over the surface of the cheek muscles (Fig. 48A, B). They innervate mainly the infraorbital canal organs and partly the cheek skin.

The ramus hyoideus is separated from the ramus mandibularis facialis in the hyomandibular and passes down to the hyoid arch (Fig. 49). Primarily, this ramus courses downward to the interhyal, before running anteroventrally along the ventral margin of the epihyal (Fig. 49B). This nerve lies medially to the third to last branchiostegal rays, giving off many branches innervating the hyohyoidei abductor-*es*. It also runs through the gap between the second and third branchiostegal rays,

and ultimately innervates the surface of the protractor hyoidei.

The ramus mandibularis facialis passes over the posterior region of the suspensorium and runs anteroventrally near the symplectic. It splits into two ramuli: the ramulus mandibularis internus facialis and ramulus mandibularis externus facialis (Fig. 48D). The former is located above the symplectic, passing lateral to the medial face of the suspensorium. It also approaches the ramulus mandibularis externus facialis, both ramuli thereafter continuing to the anterior region of the lower jaw, where they meet the ramulus mandibularis internus trigeminus on the medial side of the anguloarticular (Fig. 49A). The ramulus mandibularis externus facialis passes ventrally to the symplectic, being accompanied anteriorly by the ramulus mandibularis internus facialis (Fig. 49A). Both ramuli ultimately innervate the intermandibularis and protractor hyoidei.

The ramus opercularis facialis arises from the truncus hyomandibularis (=ramus hyoideus plus ramus mandibularis facialis) before the latter enters the hyomandibular (Fig. 49A). It courses posteriorly, innervating the levator operculi and adductor operculi.

The ramus palatinus facialis exits from the anterior foramen of the myodome, to run forward to the lateral ethmoid (Fig. 48D) and pass through the gap between the latter and adductor arcus palatini, before splitting into several branches innervating the anteroventral region of the palatine.

The ramus lateralis accessorius facialis (RLA) originates from the geniculate

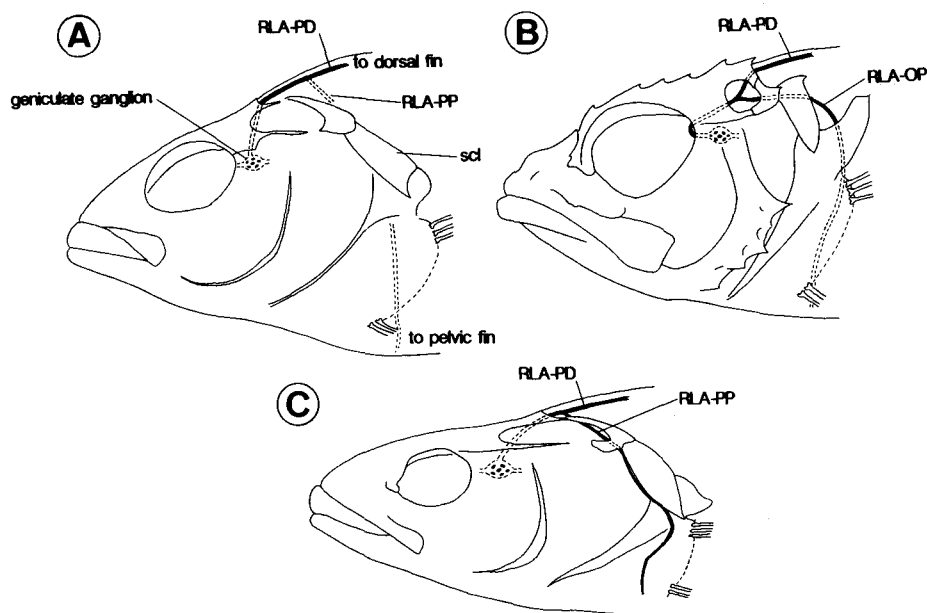

Fig. 50. Ramus lateralis accessorius (RLA) patterns. A, *Hexagrammos agrammus* (Hexagrammidae); B, *Sebastolobus macrochir* (Scorpaenidae); C, *Anoplopoma fimbria* (Anoplopomatidae).

ganglion. It courses dorsally along the inner wall of the cranium, and exits to the orbital cavity through the parietal (Fig. 50A). This ramus continues to run posteriorly, being divided into the parieto-dorsal (RLA-PD) and parieto-pectoral (RLA-PP) branches. The former runs posteriorly under the skin and dorsal fin base, to form a longitudinal plexus which crosses the dorsal rami of the spinal nerves. The latter passes down to the occipito-spinal ganglion existing between the cranium and first vertebra, and runs along Baudelot's ligament laterally to the pectoral fin base through the scapular foramen. It finally innervates the pelvic fin rays.

Character argumentation. Three facial nerve characters were recognized and polarized (Characters 49-51).

I. Apomorphic characters found in "Hexagrammoidei"

Character 49. Presence of RLA pattern 12

RLA pattern 12 of Freihofer (1963) is characterized by two conditions: (1) RLA has a single cranial exit through the parietal, and (2) the parietal-pectoral branch (RLA-PP) passes into the occipito-spinal ganglion before reaching the pectoral fin. This pattern was found in all "Hexagrammoidei". Since the pattern is not present in basal acanthopterygians, it is considered apomorphic. The same condition is also found in the cottoids (Freihofer, 1963; pers. obs.).

II. Apomorphic characters absent in "Hexagrammoidei", but present in other Scorpaeniformes

Character 50. Presence of RLA pattern 11

This RLA pattern is characterized by the following conditions: (1) RLA exits from the cranium through the trigeminal foramen of the prootic and enters the sphenotic, (2) it again exits from the cranium, to quickly split into two branches (RLA-OP and RLA-PD) at the posterior part of the pterotic, and (3) the RLA-OP (orbito-pectoral branch) passes posteroventrally medial to the posttemporal, supra-cleithrum and cleithrum (Fig. 50B). This pattern was found in all scorpaenids examined, except *Apistus*, and an aploactinid, *Erisphex*. RLA was absent in *Apistus* and the remaining scorpaeniforms examined, except the anoplomatids. Since it is not found in basal acanthopterygians, it is considered a derived condition.

Character 51. Presence of RLA pattern 7(?)

This pattern was present in all anoplomatoids (*Anoploma* and *Eriolepis*), and is characterized by having RLA-PP lying anterior or lateral to the pectoral girdle (Fig. 50C). Since basal acanthopterygians never show the same pattern, pattern 7(?) is considered apomorphic.

III. Other characters

None.

VIII. External morphology

The lateral line and fins, which have been used in taxonomic studies (e.g., Matsubara, 1955; Rutenberg, 1962; Quast, 1965) are described and discussed in this section.

Description. Lateral line: one lateral line is present on the side of the body in *Oxylebius*, *Zaniolepis*, *Ophiodon* and *Hexagrammos agrammus*. *Pleurogrammus* and the remaining species of *Hexagrammos* possess five lateral lines on each side of the

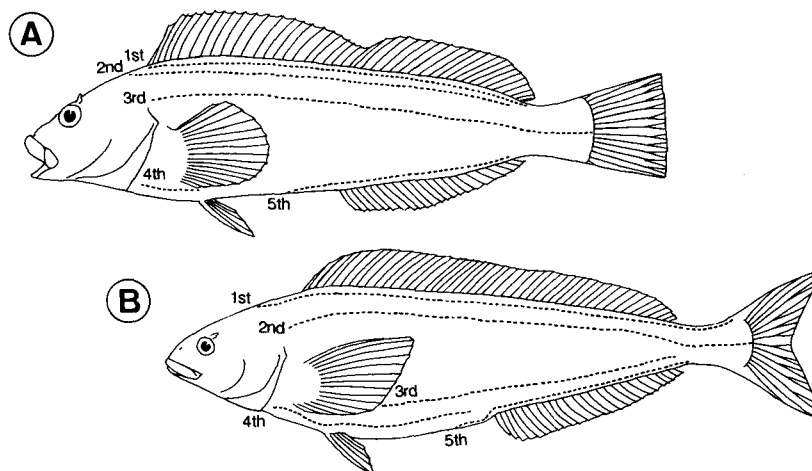

Fig. 51. Two patterns of lateral line multiplication. A, *Hexagrammos*-type; B, *Pleurogrammus*-type.

body. *Pleurogrammus* shows a basically different arrangement of multiple lateral lines from that of *Hexagrammos* (excluding *H. agrammus*). A single, additional line is present above and three below the mediolateral line, which is thought to be a primary lateral line (Fig. 51B). Most *Hexagrammos* species possess two lines above and below the mediolateral line (Fig. 51A)

Fin: the dorsal fin is long and divided into two parts by a notch in *Oxylebius*, *Zaniolepis*, *Ophiodon* and *Hexagrammos*. *Pleurogrammus* has an entire dorsal fin (Fig. 51B). Four long spines (second the longest) are connected by a deeply incised fin membrane in *Zaniolepis* (see Rutenberg, 1962). The anal fin base is long. Three spines are present in *Oxylebius* and *Zaniolepis*. The caudal fin is forked in *Pleurogrammus* but round in *Oxylebius*, three species of *Hexagrammos* (*H. lagocephalus*, *H. octogrammus* and *H. agrammus*) and *Zaniolepis frenata*. It is truncate or slightly emarginate in the remaining species of *Hexagrammos* and *Zaniolepis latipinnis*.

Character argumentation. Two external morphological characters were recognized and polarized (Characters 52, 53).

Character 52. *Pleurogrammus*-type multiplication of lateral line

Lateral lines number five in *Pleurogrammus*, such multiplication being considered apomorphic because of its non-occurrence in basal acanthopterygians. Its homology with *Hexagrammos* is ambiguous because of the differing patterns. According to Rutenberg (1962), the *Pleurogrammus* condition may suit its pelagic habitat, such being rare in the scorpaeniformes. Therefore, it is judged to be a different derived condition from that of *Hexagrammos*.

Character 53. *Elongation of first four dorsal fin spines*

This condition is apparently unique to *Zaniolepis* among the Scorpaeniformes (Matsubara, 1943b; Matsubara and Ochiai, 1955; Watanabe, 1958; Eschmeyer,

1965, 1969; Ueno, 1970; Eschmeyer and Rama-Rao, 1973; Eschmeyer et al., 1973, 1979; Kido, 1988; Kanayama, 1991). Since basal acanthopterygians do not have such elongated dorsal fin spines, it is regarded as a derived condition.

Other characters

Hexagrammos-type multiplication of lateral line

The *Hexagrammos*-type multiplication of the lateral line may be apomorphic because the same condition is unknown in basal acanthopterygians such as berycoids and percoids (e.g., Lindberg, 1971; Nelson, 1984). However, the character could not be used in the analysis because of its variation within *Hexagrammos* (see Chapter X).

IX. Phylogenetic position of genera belonging to suborder "Hexagrammoidei"

1. Relationships of scorpaeniform genera, including "hexagrammoids"

The apomorphic characters are listed in Table 3 and their distributions shown in Table 4. The interrelationships of 41 scorpaeniform genera were reconstructed on the basis of 53 advance characters. Although the cladistic analysis resulted in 220 most parsimonious trees (consistency index=0.479), the conflicting parts of these trees were mainly concentrated around the relationships within the scorpaenoid and platycephaloid genera. In this study, a strict consensus tree (Sokal and Rohlf, 1981) was used for determination of the latter relationships. The consensus cladogram has fourteen stems, as A1-A14, near the root, with the genera of "Hexagrammoidei" being positioned in a monophyletic group (A14), which includes the anoplopomatoids and cottoids (Fig. 52). This monophyletic group involves substems B1 and B2, branches C1 and C2, and subbranches D1 and D2 (Fig. 53). The character numbers labelled "r", indicate reversals.

Monophyly of Scorpaeniformes

A definition of the order Scorpaeniformes has already been established, according to three characters: presence of a suborbital stay, parietal supporting a sensory canal and presence of a swimbladder muscle (see Chapter IV). Following the present analysis, three further characters were newly added to the above definition: (Character 3) absence of a suborbital shelf, (23) absence of beryciform foramen, and (31) presence of accessory spine on head of cleithrum. Reversals from these conditions are important as derived characters in the cladogram.

Interrelationships of stem A14 including "Hexagrammoidei"

Stem A14 is composed of *Erilepis*, *Anoplopoma*, *Zaniolepis*, *Oxylebius*, *Ophiodon*, *Pleurogrammus*, *Hexagrammos* and all cottoids, and is defined by seven characters (Fig. 53A): (8) parasphenoid attached with pterosphenoid, (22) six branchiostegal rays, (26) absence of tooth plate on third epibranchial, (31r) absence of accessory spine on head of cleithrum, (34) absence of predorsal, (36) dorsal pterygiophores arranged singly in each interneural space, and (37) absence of anal spines with robust pterygiophores.

Substem B1 includes two anoplopomatoids, *Erilepis* and *Anoplopoma*. It is supported by two synapomorphies: (42) robust hypurapophysis, and (51) presence of RLA pattern 7(?).

Table 3. List of apomorphic characters.

-
1. Presence of primary tubules on first infraorbital
 2. Dermosphenotic loosely attached to sphenotic
 3. Absence of suborbital shelf
 4. Presence of lachryopalatine articulation
 5. Presence of lachrymal spines on ventral margin
 6. Second infraorbital attached to lateral ethmoid
 7. Lachrymal with anteriorly projecting spine
 8. Parasphenoid attached to pterosphenoid
 9. Presence of a relatively thin, rounded supraoccipital crest
 10. Presence of preocular spine
 11. Presence of spines on postorbital region of skull
 12. Presence of parietal-nuchal spines
 13. Anterodorsal arm of posttemporal covered by parietal
 14. Presence of narrow cartilaginous band on ventral face of frontal
 15. Reduction of ascending process of anguloarticular
 16. *Hexagrammos*-type dentition in upper jaw
 17. Presence of canines in both jaws
 18. Absence of notch between ascending and articular processes in premaxillary
 19. Separation of ascending process from remaining part in premaxillary
 20. Presence of inner projection on metapterygoid
 21. Operculo-mandibular canal region of preopercle covered by adductor mandibulae
 22. Six branchiostegal rays
 23. Absence of beryciform foramen
 24. Absence of basihyal
 25. Hypobranchials polygonal and plate-like
 26. Absence of tooth plate on third epibranchial
 27. Presence of cartilaginous second and third basibranchials
 28. Coracoid arm robust and broadly attached to cleithrum
 29. First actinost fused to scapula
 30. All actinosts sandwiched by scapula and coracoid
 31. Presence of accessory spine on head of cleithrum
 32. Presence of sacking disc
 33. Decrease in number of soft rays in pelvic fin
 34. Absence of predorsal
 35. Spinous dorsal fin proximal and distal pterygiophores separated
 36. Dorsal pterygiophores arranged singly in each interneural space
 37. Absence of anal spines with robust pterygiophores
 38. Absence of stay in dorsal and anal fin supports
 39. Plate-like first neural spine
 40. First two neural spines bent forward
 41. Absence of hypurapophysis
 42. Robust hypurapophysis
 43. A2 section branched anteriorly
 44. A1 section divided into inner and outer subsections.
 45. Absence of third levator externus
 46. Reduced arrector ventralis
 47. Absence of extensor proprius
 48. Presence of adductor dorsalis
 49. Presence of RLA pattern 12
 50. Presence of RLA pattern 11
 51. Presence of RLA pattern 7 (?)
 52. *Pleurogrammus*-type multiplication of lateral line
 53. Elongation of first four dorsal fin spines
-

Table 4. Character matrix for examined scorpaeniform genera. 0, primitive state; 1, derived state.

	Character No.										
	1-5	6-10	11-15	16-20	21-25	26-30	31-35	36-40	41-45	46-50	51-
outgroup	00000	00000	00000	00000	00000	00000	00000	00000	00000	00000	000
<i>Setarches</i>	00101	00001	11000	00000	00100	00000	10000	00000	00000	00101	000
<i>Neosebastes</i>	00101	00001	11100	00000	00100	00010	10010	00000	00001	10101	000
<i>Pontinus</i>	00101	00001	11100	00000	00100	00000	10000	00000	00000	00101	000
<i>Scorpaenodes</i>	00001	00001	11100	00000	00100	00000	10010	00000	00001	00101	000
<i>Sebastes</i>	00001	00001	11100	00000	00100	00010	10000	00000	00000	00101	000
<i>Dendrochirus</i>	00100	00001	11100	00000	00100	00000	00010	00000	00000	00101	000
<i>Sebastiscus</i>	00001	00001	11100	00000	00100	00010	10000	00000	00000	00101	000
<i>Hozukius</i>	00001	00001	11100	00000	00100	00010	10000	00000	00000	00101	000
<i>Helicolenus</i>	00000	00001	11100	00000	00100	00010	10000	00000	00000	00101	000
<i>Scorpaena</i>	00101	00001	11100	00000	00100	00010	10010	00000	00000	00101	000
<i>Sebastolobus</i>	00101	00001	11100	00000	00100	00000	00000	00000	00000	00101	000
<i>Scorpaenopsis</i>	00101	00001	11100	00000	00100	00010	10010	00000	00000	00101	000
<i>Paracentropogon</i>	00001	00000	00000	00000	01110	10010	10110	00001	00000	00101	000
<i>Apistus</i>	00101	00001	10100	00000	00100	00010	10000	00001	00000	00100	000
<i>Minous</i>	00101	00000	01100	00000	00100	10010	10010	00101	00000	00000	000
<i>Inimicus</i>	00101	00000	01100	00000	00100	10010	10010	00101	00001	00000	000
<i>Erisphez</i>	00101	00000	00000	00000	00100	10010	10110	00101	10001	11001	000
<i>Chelidonichthys</i>	00100	11001	00000	00000	00110	00000	10010	01000	00000	00000	000
<i>Peristedion</i>	00100	11000	00000	00000	00110	10000	10010	01000	00000	10000	000
<i>Bembras</i>	00101	00001	11000	00000	00100	00000	10000	01000	00000	00100	000
<i>Rogadius</i>	00100	00001	01000	00010	00100	00000	10010	01010	00000	00000	000
<i>Suggrundus</i>	00100	00001	11000	00010	00100	00000	10010	01010	00000	00000	000
<i>Hoplichthys</i>	00100	00001	01000	00010	00100	00000	10010	01110	00000	00000	000
<i>Erilepis</i>	00100	00100	00000	00000	01100	10000	00010	01000	01000	00000	100
<i>Anoplopoma</i>	00100	00100	00001	00000	01100	10000	00010	11100	01000	00000	100
<i>Oxylebius</i>	00110	00100	00001	00100	01100	10000	00000	10000	00000	00010	000
<i>Zaniolepis</i>	00110	00100	00001	00000	01100	10000	00010	10000	00000	00010	001
<i>Hexagrammos</i>	11110	00110	00000	10001	11101	10100	00011	11100	10100	11010	000
<i>Pleurogrammus</i>	11110	00110	00000	00000	11101	10100	00011	11100	10000	11010	010
<i>Ophiodon</i>	11110	00110	00000	01000	11100	00000	00011	11100	10000	10010	000
<i>Enophrys</i>	01110	00100	00000	00000	01010	10000	00111	11100	10001	11010	000
<i>Myoxocephalus</i>	01110	00100	00000	00000	01010	10000	00111	11100	10001	11010	000
<i>Triglops</i>	01110	00100	00000	00000	01010	10000	00111	11100	10001	11010	000
<i>Hemilepidotus</i>	01110	00100	00000	00000	01010	10000	00111	11100	10001	11010	000
<i>Blepsias</i>	01110	00100	00000	00000	01110	10000	00111	11100	10001	11010	000
<i>Malacocottus</i>	01110	00100	00000	00000	00010	10000	00111	11100	10001	11010	000
<i>Dasycottus</i>	01110	00100	00000	00000	00010	10000	00111	11100	10001	11010	000
<i>Occella</i>	01110	00100	00000	00000	01010	10000	00111	11100	10001	11010	000
<i>Liparis</i>	01110	00100	00010	00000	01010	11001	01011	11100	10011	11010	000
<i>Careproctus</i>	01110	00100	00010	00000	01010	11001	01011	11100	10011	11010	000
<i>Eumicrotremus</i>	01110	00100	00000	00000	01010	11001	01011	11100	10011	11010	000

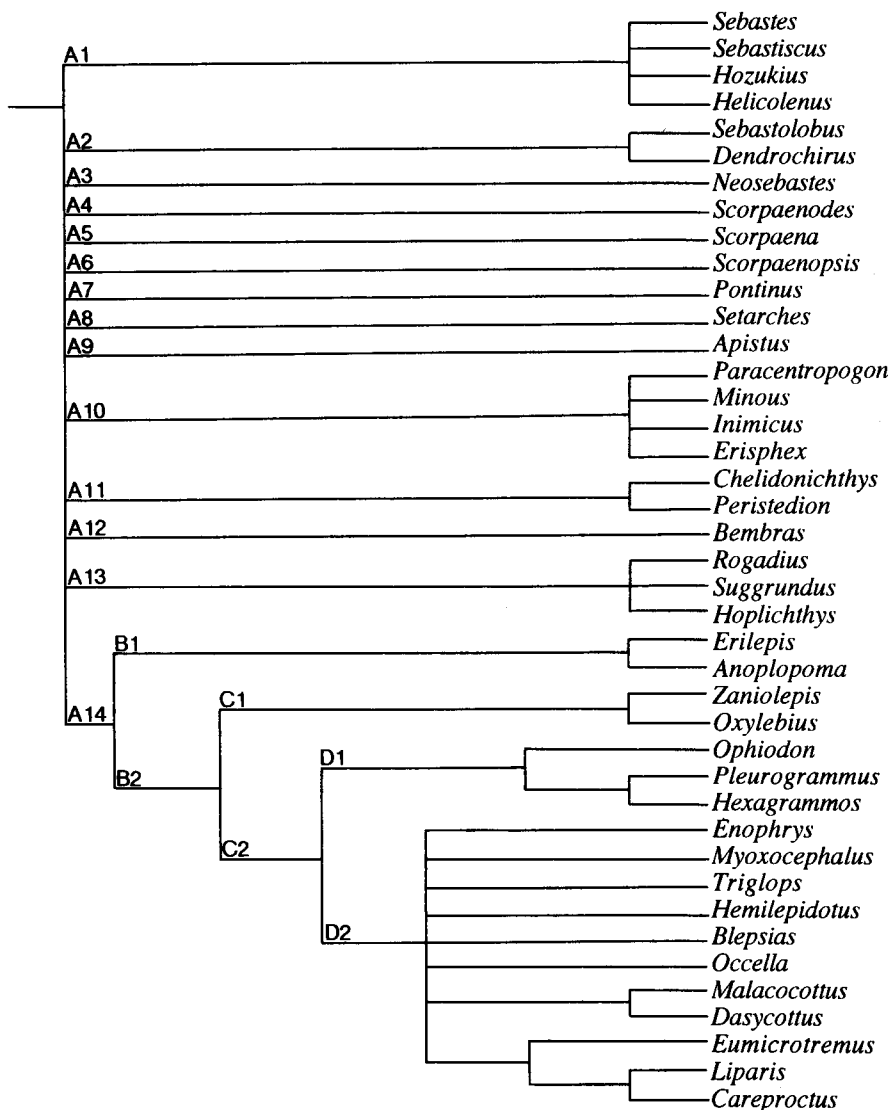

Fig. 52. Consensus cladogram of 41 scorpaeniform genera.

Substem B2 includes *Zaniolepis*, *Oxylebius*, *Ophiodon*, *Pleurogrammus*, *Hexagrammos* and all cottoids. It is supported by two characters: (4) presence of lachryopalatine articulation, and (49) presence of RLA pattern 12.

Branch C1 includes *Zaniolepis* and *Oxylebius*, and is supported by two synapomorphies (Fig. 53B): (15) reduction of ascending process of anguloarticular, and (37r) presence of anal spines with robust pterygiophores. *Zaniolepis* has one apomorphy (autapomorphy): (53) elongation of first four dorsal fin spines.

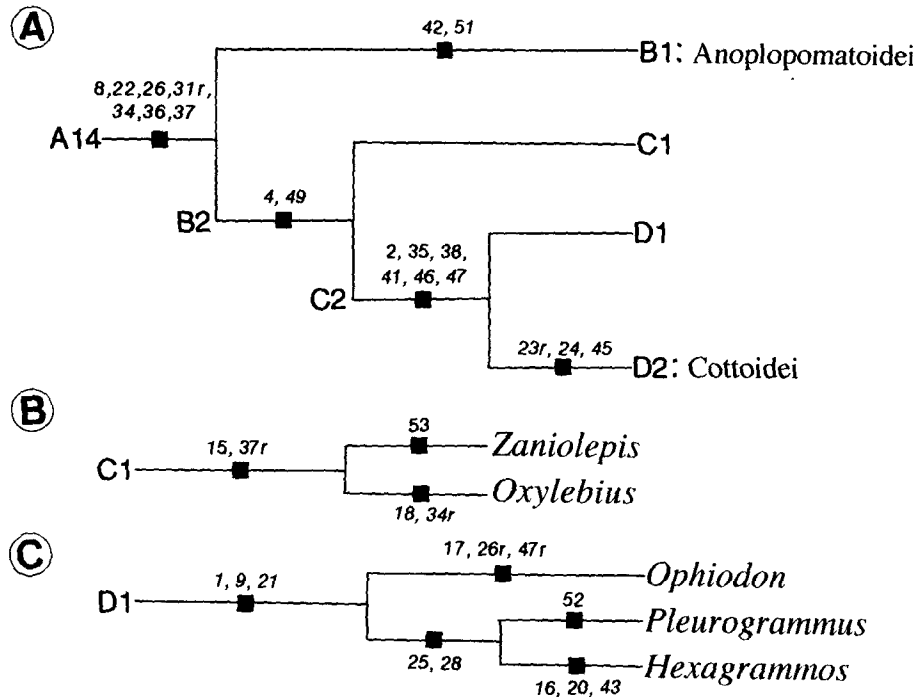

Fig. 53. Branching patterns and character distributions in a monophyletic group, including "Hexagrammoidei". A, stem A14; B, branch C1; C, subbranch D1. Character numbers correspond to those of Table 3.

Oxylebius has two apomorphies: (18) absence of notch between ascending and anterior processes in premaxillary, and (34r) presence of predorsal.

Branch C2 comprises *Ophiodon*, *Pleurogrammus*, *Hexagrammos* and the cottoids, and is defined by six synapomorphies: (2) dermosphenotic loosely attached to sphenotic, (35) spinous dorsal fin proximal and distal pterygiophores separated, (38) absence of stay in dorsal and anal fin supports, (41) absence of hypurapophysis, (46) reduced arrector ventralis, and (47) absence of extensor proprius.

Subbranch D1 comprises *Ophiodon*, *Pleurogrammus* and *Hexagrammos*, and is defined by three synapomorphies (Fig. 53C): (1) presence of primary tubules on first infraorbital bone, (9) presence of a relatively thin, rounded supraoccipital crest, and (21) operculo-mandibular canal region of preopercle covered by adductor mandibulae. *Ophiodon* has three apomorphies: (17) presence of canines in both jaws, (26r) presence of tooth plate on third epibranchial, and (47r) presence of extensor proprius. *Pleurogrammus* and *Hexagrammos* share two characters: (25) hypobranchials polygonal and plate-like, and (28) coracoid arm robust and broadly attached to the cleithrum, with *Pleurogrammus* having a further synapomorphy: (52) *Pleurogrammus*-type multiplication of lateral line. *Hexagrammos* has three synapomorphies: (16) *Hexagrammos*-type dentition in upper jaw, (20) presence of inner projection on metapterygoid, and (43) A2 section branched anteriorly.

Subbranch D2 includes all cottoids (Fig. 53A). It is supported by three synapomorphies: (23r) presence of beryciform foramen, (24) absence of basihyal, and (45) absence of third levator externus.

2. Phylogenetic position of "hexagrammoid" genera

The "Hexagrammoidei" (*sensu* Nelson, 1984) has resulted in being separated into two clades, one containing *Zaniolepis* and *Oxylebius* in branch C1, and the other including *Ophiodon*, *Pleurogrammus* and *Hexagrammos* in subbranch D1 (Fig. 53). Since the relationships of these groups are paraphyletic (*sensu* Wiley et al., 1991), the suborder "Hexagrammoidei" is considered to be an artificial taxon. The two above groups are included in a large, monophyletic group (from stem 14), which includes two suborders, Anoplopomatoidei and Cottoidei (*sensu* Nelson, 1984). *Zaniolepis* and *Oxylebius* are located between the anoplopomatoids and a monophyletic group including the other "hexagrammoids" and all cottoids. *Ophiodon*, *Pleurogrammus* and *Hexagrammos* are represented by the cladogram as being most closely related to the suborder Cottoidei.

3. Comparison with previous works

The "hexagrammoid" relationships with the other scorpaeniforms and their "supposed" monophyly have been commented on by Gill (1889), Regan (1913), Berg (1940), Matsubara (1943a) and Quast (1965), resulting in two hypotheses regarding taxa closely related to the "Hexagrammoidei". Matsubara (1943a) believed that the "hexagrammoids" were located nearby the anoplopomatoids phylogenetically, on the basis of some morphological characters. However, a close relationship of the "hexagrammoids" with the cottoids was presented by Quast (1965), who proposed that the Scorpaeniformes evolved along three basic lineages, on the basis of osteological characters: the cottid-hexagrammid (including the cyclopterids, agonids and psychrolutids), anoplopomatid, and scorpaenid (including the platycephalids). This study supports of the latter hypothesis because the "hexagrammoids" form a monophyletic group with the Cottoidei.

The paraphyly of the "Hexagrammoidei" suggested by the cladogram in this study is a notably different hypothesis from all previous ones. Historically, the "hexagrammoids" have been treated as a natural group by many authors, including Regan (1913), Berg (1940), Matsubara (1955), Rutenberg (1962), Quast (1965), Gosline (1971) and Nelson (1976, 1984). Although Regan (1913) and Quast (1965) used the several osteological and external characters for defining the group, such had not been well evaluated with those of the other scorpaeniforms. Since they included some primitive characters, such as the presence of the basisphenoid, in the diagnosis of the "hexagrammoids", the definition of the latter has been ambiguous until now. Since the present cladistic analysis splits the "hexagrammoids" into two monophyletic groups, one being closely related to the cottoids, the "hexagrammoids" should be no longer treated as taxon and all past hypotheses should be rejected.

X. Relationships of *Hexagrammos* species

Hexagrammos is generally believed to contain six species, *H. agrammus*, *H.*

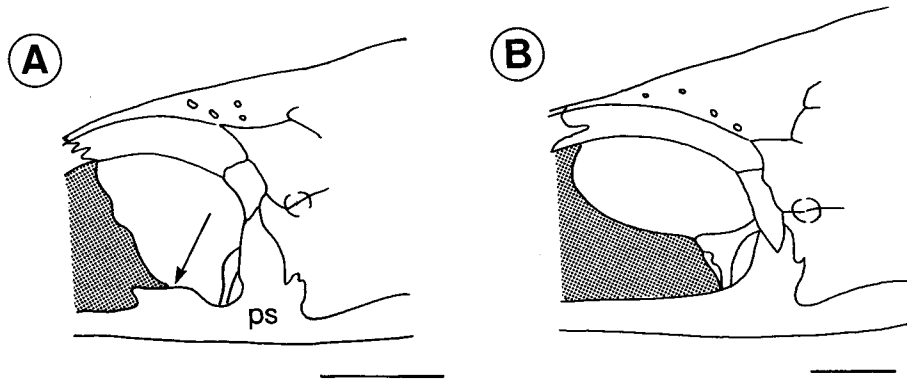

Fig. 54. Lateral aspect of posterior region of orbit. A, *Hexagrammos lagocephalus*; B, *H. decagrammus*. Bars=5 mm.

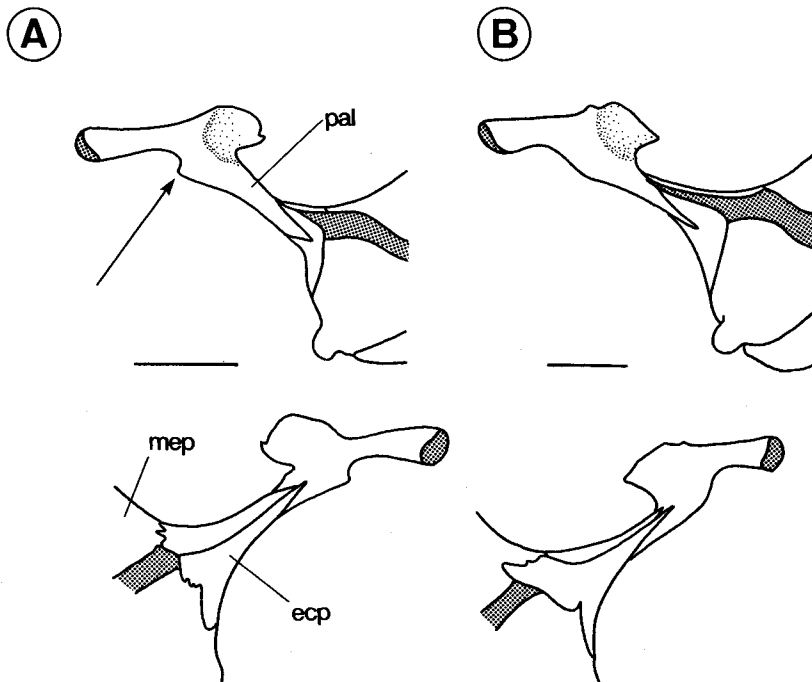

Fig. 55. Lateral (above) and medial (below) aspects of anterior part of suspensorium. A, *Hexagrammos stelleri*; B, *H. otakii*. Bars=5 mm.

otakii, *H. octogrammus*, *H. lagocephalus*, *H. decagrammus* and *H. stelleri* (Nelson, 1984; Washington et al., 1984a). In this section their relationships are examined on the basis of their osteology, myology, squamation, external characters and meristic counts.

1. Character description and polarity in *Hexagrammos* species

Hexagrammos is related primarily to *Pleurogrammus* and secondarily to *Ophiodon*, the three genera forming a monophyletic group. The plesiomorphic character state in *Hexagrammos* is determined by the presence of the state in both outgroups. A third outgroup, Cottoidei, is not used owing to the difficulty in comprehension of all species conditions (ca. 600 species, Nelson, 1984).

1. Osteological characters.

(#1) Absence of knob-like structure on dorsal margin of parasphenoid

A knob-like projection, present on the anterodorsal margin of the parasphenoid in *H. octogrammus* and *H. lagocephalus* (Fig. 54A), is also present in *Pleurogrammus azonus* and *Ophiodon elongatus* (absent in *P. monoptyerigiis*). Its absence is regarded as a derived condition.

(#2) Smooth ventral profile of palatine

This condition, found in *H. agrammus*, *H. otakii*, *H. octogrammus* and *H. lagocephalus* (Fig. 55B), is considered to be apomorphic because all of the species in both outgroups possess a projecting portion on the ventral margin of the palatine.

(#3) Ectopterygoid attached to metapterygoid on medial side of suspensorium

This condition is present in all *Hexagrammos* species, except *H. stelleri* (Fig. 55). Since these bones are separated from each other medially in both outgroups, their

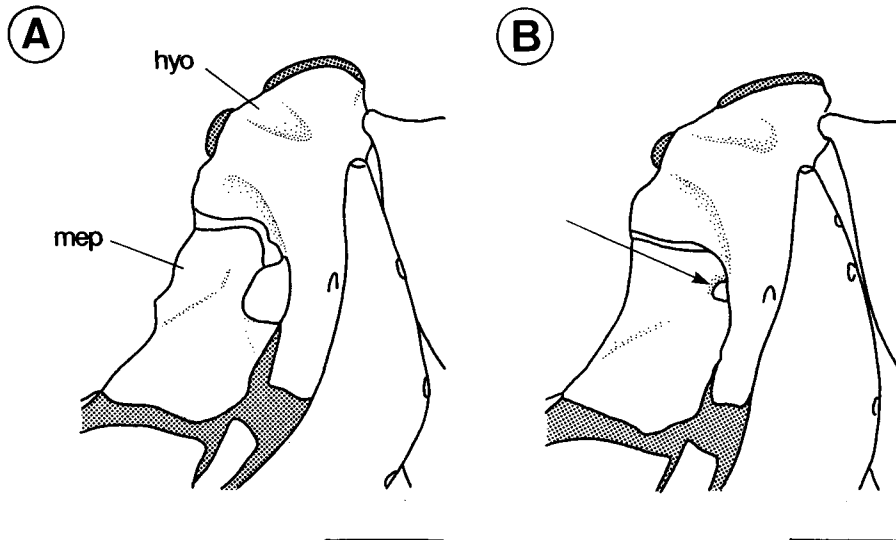

Fig. 56. Lateral aspect of metapterygoid and hyomandibular region. A, *Hexagrammos decagrammus*; B, *H. otakii*. Bars=5 mm.

attachment is regarded as apomorphic.

(#4) *Reduction of metapterygoid foramen*

This condition is present in *H. agrammus* and *H. otakii* (Fig. 56B). Since both outgroups have a large foramen on the metapterygoid margin, its reduction is regarded as apomorphic.

(#5) *Presence of lateral keel on urohyal*

This condition was observed in *H. agrammus*, *H. otakii*, *H. octogrammus* and *H. lagocephalus* (Fig. 57B), whereas all species of *Pleurogrammus* and *Ophiodon* lacked such a keel. Presence of the keel is therefore regarded as apomorphic.

(#6) *Interdigitation between ceratohyal and epihyal*

The ceratohyal and epihyal interdigitate on their lateral aspects in *H. agrammus*, *H. otakii*, *H. decagrammus* and *H. stelleri* (Fig. 58B). Since the lateral connection of these bones is by cartilage in *Pleurogrammus* and *Ophiodon*, such an interdigitation is regarded as apomorphic.

2. Myological characters.

None.

3. Squamation.

(#7) *Basal part of membrane of posterior dorsal fin covered with scales*

The basal region of the soft-rayed section of the dorsal fin is covered with scales

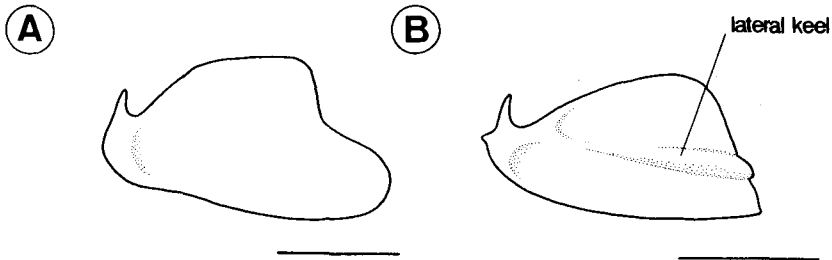

Fig. 57. Lateral aspect of urohyal. A, *Hexagrammos decagrammus*; B, *H. agrammus*. Bars = 5 mm.

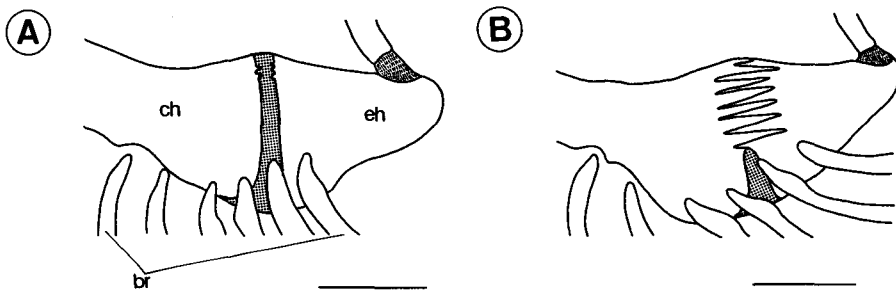

Fig. 58. Lateral aspect of hyoid arch. A, *Hexagrammos lagocephalus*; B, *H. stelleri*. Bars = 5 mm.

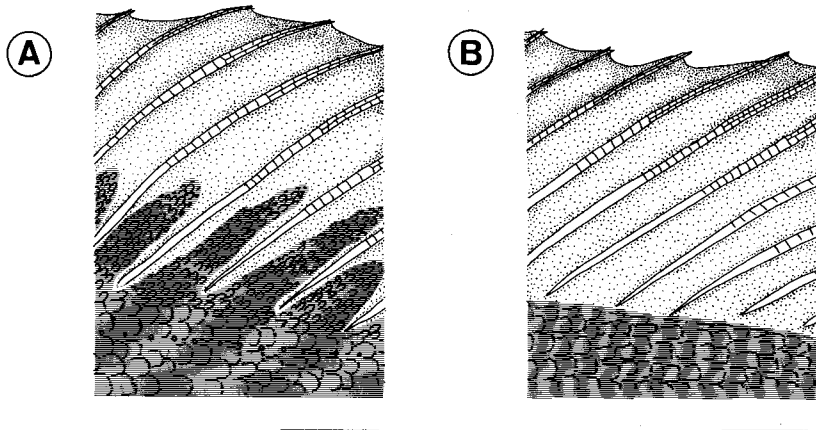

Fig. 59. Lateral aspect of posterior part of dorsal fin. A, *Hexagrammos lagocephalus*; B, *H. stelleri*. Bars=5 mm.

in *H. agrammus*, *H. otakii*, *H. octogrammus*, *H. lagocephalus* and *H. decagrammus* (Fig. 59A). This is regarded as a derived condition because all species of both outgroups lack scales in this region.

4. External characters.

(#8) *Presence of small flap on posterior region of head*

A small flap on the posterior region of the head in *H. agrammus*, *H. otakii* and *H. decagrammus* (Fig. 60B), is absent in all species of both outgroups. Presence of the flap is regarded as apomorphic.

(#9) *Hexagrammos-type multiplication of lateral line*

The *Hexagrammos*-type multiplication of the lateral line (see Chapter VIII) was found all *Hexagrammos* species, except *H. agrammus*, being different from the arrangement in *Pleurogrammus*. *Ophiodon* possesses one lateral line. Therefore, the *Hexagrammos*-type lateral line is regarded as apomorphic.

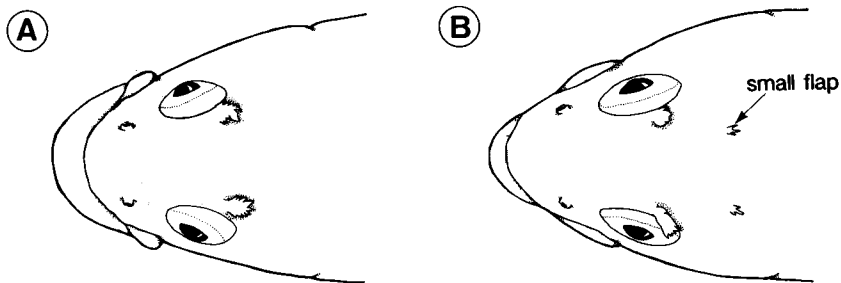

Fig. 60. Dorsal aspect of head region. A, *Hexagrammos octogrammus*; B, *H. decagrammus*.

Table 5. Meristic counts of *Hexagrammos*, *Pleurogrammus* and *Ophiodon*. Data compiled from Rutenberg (1962), Kendall and Vinter (1984), and Masuda et al. (1984).

	Dorsal fin		Anal fin rays	Pectoral fin rays	Vertebrae
	spines	rays			
<i>Hexagrammos agrammus</i>	17-19	19-23	18-21	16-18	46-50
<i>H. otakii</i>	19-21	21-23	21-23	17-19	50-52
<i>H. octogrammus</i>	17-20	22-25	23-26	17-19	51-53
<i>H. lagocephalus</i>	20-23	20-25	20-24	18-22	53-57
<i>H. decagrammus</i>	21-23	22-26	23-26	18-22	55-56
<i>H. stelleri</i>	20-25	18-23	22-25	18-20	52-55
<i>Pleurogrammus azonus</i>	21-23	28-29	27-32	22-25	60-62
<i>P. monopterygius</i>	21-24	24-30	23-28	23-28	59-61
<i>Ophiodon elongatus</i>	24-28	19-24	21-27	16-18	55-57

5. Meristic characters.

Counts of *Hexagrammos*, *Pleurogrammus* and *Ophiodon* species are shown in Table 5. Meristic characters were transformed into several character states by the range gap-coding method (see Chapter IV). The number of lateral line scales could not be used because of a lack of information for *H. decagrammus*. The plesiomorphic condition could not be determined for dorsal, pectoral and vertebral numbers, which were therefore omitted from the analysis.

(#10) Decreased number of anal fin rays

Judging from the range of all species of *Pleurogrammus* and *Ophiodon*, the plesiomorphic anal fin ray number is twenty seven. The lower number in *Hexagrammos* is therefore regarded as derived. There apomorphic conditions (states 1, 2

Table 6. Coding of anal fin ray numbers in *Hexagrammos*. Taxon A, *H. agrammus*; C, *H. octogrammus*; D, *H. decagrammus*; L, *H. lagocephalus*; S, *H. stelleri*; T, *H. otakii*; out, outgroup.

	taxon						
	(out)	D	C	S	T	L	A
state 1							
state 2							
state 3							
state 1	0	0	0	1	1	1	1
state 2	0	0	0	0	1	1	1
state 3	0	0	0	0	0	1	1
Coding	0	0	0	1	2	3	3

and 3) were found in this genus (Table 6). The primary apomorphic condition, less than 23, is present in *H. stelleri*, *H. otakii*, *H. lagocephalus* and *H. agrammus*. The secondary apomorphic condition (state 2: number less than 22) defines a group including *H. otakii*, *H. lagocephalus* and *H. agrammus*. The most advanced one (state 3: less than 21) is present in *H. lagocephalus* and *H. agrammus*.

2. Interrelationships of *Hexagrammos* species

Data matrix is shown in Table 7. A cladistic analysis based on the above 10 characters resulted in one most parsimonious tree (consistency index=0.706) (Fig.

Table 7. Character matrix for *Hexagrammos* species. 0, primitive state; 1-3, derived states.

	Character No.									
	1	2	3	4	5	6	7	8	9	10
outgroup	0	0	0	0	0	0	0	0	0	0
<i>H. agrammus</i>	1	1	1	1	1	1	1	1	0	3
<i>H. otakii</i>	1	1	1	1	1	1	1	1	1	2
<i>H. octogrammus</i>	0	1	1	0	1	0	1	0	1	0
<i>H. lagocephalus</i>	0	1	1	0	1	0	1	0	1	3
<i>H. decagrammus</i>	1	0	1	0	0	1	1	1	1	0
<i>H. stelleri</i>	1	0	0	0	0	1	0	0	1	1

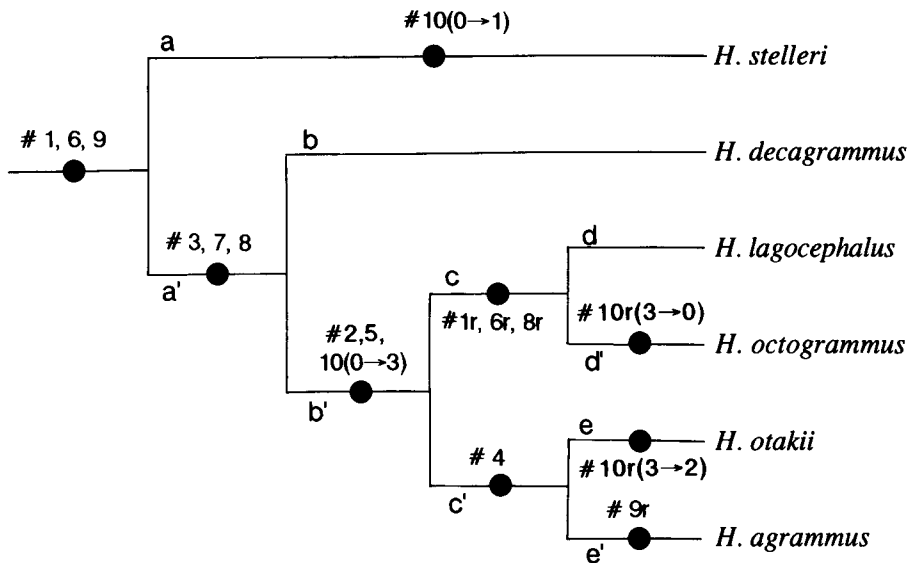

Fig. 61. Interrelationships of *Hexagrammos* species. Character numbers correspond to those of text.

61). The "r" indicates the reversal of a character state.

Monophyly of genus Hexagrammos

Hexagrammos has been defined in Chapter IX by three derived characters : (16), (20) and (43). Three further characters were newly added to the above definition, on the evidence of the monophyly of the genus : (#1) absence of knob-like structure on dorsal margin of parasphenoid, (#6) interdigitation between ceratohyal and epihyal, and (#9) *Hexagrammos*-type multiplication of lateral line.

Branch a contains only *Hexagrammos stelleri*, with one apomorphy : (#10) decreased number of anal fin rays (states : 0 to 1).

Branch a' includes the remaining species, *Hexagrammos decagrammus*, *H. lagocephalus*, *H. octogrammus*, *H. otakii* and *H. agrammus*, and is supported by three characters : (#3) ectopterygoid attached to metapterygoid on medial side of suspensorium, (#7) basal part of membrane of posterior dorsal fin covered with scales, and (#8) presence of small flap on posterior region of head.

Branch b contains *Hexagrammos decagrammus*, having no further apomorphies. This species forms a sister group or is ancestral to the remaining species of *Hexagrammos*.

Branch b' includes *Hexagrammos lagocephalus*, *H. octogrammus*, *H. otakii* and *H. agrammus*. Their monophyly is supported by three characters : (#2) smooth ventral profile of palatine, (#5) presence of lateral keel on urohyal, and (#10) decreased number of anal fin rays (states : 0 to 3).

Branch c including *Hexagrammos lagocephalus* and *H. octogrammus*, is defined by three synapomorphies : (#1r) presence of knob-like structure on dorsal margin of parasphenoid, (#6r) absence of interdigitation between ceratohyal and epihyal, and (#8r) absence of small flap on posterior region of head.

Branch c' contains *Hexagrammos otakii* and *H. agrammus*, their monophyly being defined by a single character : (#4) reduction of metapterygoid foramen.

Branch d, *Hexagrammos lagocephalus*, has no further characters. This species is a sister species or ancestral to *H. octogrammus*.

Branch d', *Hexagrammos octogrammus*, has one further character : (#10r) increased number of anal fin rays (states : 3 to 0).

Branch e, *Hexagrammos otakii*, is defined by one character : (#10r) increased number of anal fin rays (states : 3 to 2).

Branch e', *Hexagrammos agrammus*, has one further character : (#9r) absence of *Hexagrammos*-type multiplication of lateral line.

3. Comparison with other works

Two major considerations exist regarding the systematic position of *Hexagrammos agrammus*. Separation of the species from other members of *Hexagrammos*, by referring it to a separate, monotypic genus (*Agrammus*) on the basis of its single lateral line, was supported by Günther (1860), Jordan and Starks (1902), Matsubara (1955) and Rutenberg (1962). However, Quast (1964, 1965) and most recent authors (e.g., Nelson, 1984) considered the species to be very similar to other species of *Hexagrammos* in both meristic and morphometric characters, supporting its retention in *Hexagrammos*. This study supports the latter opinion because the single lateral line is thought to have been secondarily acquired by *H. agrammus*, according to the

cladogram proposed.

Excluding *H. agrammus* from *Hexagrammos*, Rutenberg (1962) established subgenus *Lebius* for *H. decagrammus* and *H. lagocephalus*, which were characterized by having palatine teeth, a long fourth lateral line and higher numbers of some meristic characters. Other species were included in subgenus *Hexagrammos*. However, this opinion is not supported by the present cladogram because Rutenberg's *Lebius* is not monophyletic.

XI. General Consideration

1. Classification

The suborder "Hexagrammoidei" (*sensu* Nelson, 1984) is considered to be an invalid higher taxon because it is not a monophyletic group in the cladistic sense. Therefore, a new classification is essential for the group on the basis of its phylogenetic relationships.

Two groups in the "Hexagrammoidei" are located between the Anoplopomatoidei and Cottoidei (both *sensu* Nelson, 1984) (Fig. 62), the two branches being able to be ranked at the same or higher level as the two above taxa, according to the sequencing convention (Nelson, 1974 ; Wiley, 1981). It is proposed here that the two monophyletic groups in the "Hexagrammoidei" be considered as two different suborders, Zaniolepidoidae being created for *Zaniolepis* and *Oxylebius*, and Hexagrammoidei being restricted to the remaining genera. Consequently, the family names Zaniolepididae and Hexagrammidae are applicable to the respective groups.

The new classification and systematic position of the scorpaeniform "hexagram-

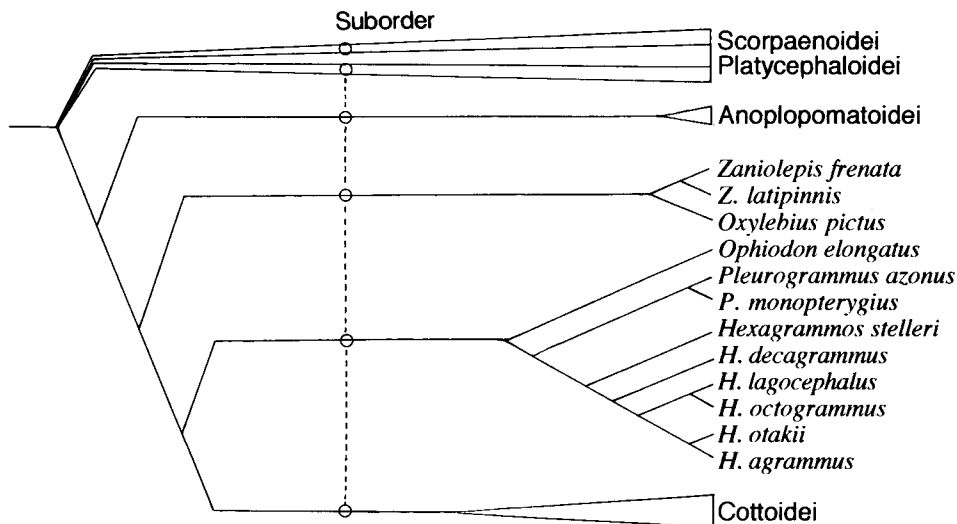

Fig. 62. Phylogenetic relationships within Scorpaeniformes and ranking of two monophyletic groups found in "hexagrammoids".

moid" fishes are summarized below.

Order Scorpaeniformes

Suborder Scorpaenoidei (*sens.* Nelson, 1984)

Suborder Platycephaloidei (*sens.* Nelson, 1984)

Suborder Anoplopomatoidei (*sens.* Nelson, 1984)

Suborder Zaniolepidoidae (*nov.*)

Family Zaniolepididae (*sens. lat.*)

Genus *Zaniolepis*

Zaniolepis latipinnis Girard, 1857

Z. frenata Eigenmann, 1889

Genus *Oxylebius*

Oxylebius pictus Gill, 1862

Suborder Hexagrammoidei (*sens. str.*)

Family Hexagrammidae (*sens. str.*)

Genus *Ophiodon*

Ophiodon elongatus Girard, 1855

Genus *Pleurogrammus*

Pleurogrammus monopterygius (Pallas, 1810)

P. azonus Jordan et Metz, 1913

Genus *Hexagrammos*

Hexagrammos stelleri Tilesius, 1810

H. decagrammus (Pallas, 1810)

H. lagocephalus (Pallas, 1810)

H. octogrammus (Pallas, 1810)

H. otakii Jordan et Starks, 1896

H. agrammus (Temminck et Schlegel, 1843)

Suborder Cottoidei (*sens.* Nelson, 1984)

Family Zaniolepididae, restricted to the two species of *Zaniolepis*, has been used by several authors (Jordan, 1923; Quast, 1965; Eschmeyer et al., 1983; Nelson, 1984). The present classification differs from them inasmuch as the family now includes a second genus, *Oxylebius*. The family is defined by two osteological characters: the reduction of ascending process of the anguloarticular and the presence of anal fin spines and robust pterygiophores.

In previous taxonomic studies, the family Hexagrammidae has been considered to include five genera, *Hexagrammos*, *Pleurogrammus*, *Ophiodon*, *Oxylebius* and *Zaniolepis* (Berg, 1940; Clemens and Wilby, 1949; Rutenberg, 1962; Washington et al., 1984a) or the former four genera (Quast, 1965; Nelson, 1984). Restricted here to only three genera, *Hexagrammos*, *Pleurogrammus* and *Ophiodon*, the family is defined by three diagnostic characters: the presence of primary tubules on the first infraorbital, the presence of a relatively thin, rounded supraoccipital crest and the operculo-mandibular canal region of the preopercle covered by the adductor mandibulae.

2. Zoogeography

(1) Distribution of suborders Hexagrammoidei and Zanioleptoidei

The two suborders, Hexagrammoidei and Zanioleptoidei, are endemic to the North Pacific Ocean, being primarily distributed in the littoral zone (Nelson, 1984). The distribution of each species in the two suborders is given below.

Ophiodon elongatus is found from the Gulf of Alaska to Baja California (Günther, 1860; Jordan and Gilbert, 1882; Jordan and Evermann, 1898; Evermann and Goldsborough, 1907; Clemens and Wilby, 1949; Follett, 1952; Rutenberg, 1962; Quast, 1964; Taylor, 1967; Fitch and Lavenberg, 1971; Quast and Hall, 1972; Miller and Lea, 1972; Hart, 1973; Nelson, 1976, 1984; Eschmeyer et al., 1983; Allen and Smith, 1988).

Pleurogrammus azonus is distributed in the Yellow Sea, Sea of Japan, southern part of the Sea of Okhotsk, and off the Kuril Islands and Pacific coast of Hokkaido (Jordan and Metz, 1913; Matsubara, 1955; Rutenberg, 1962; Ueno, 1965; Yusa, 1967; Allen and Smith, 1988; Amaoka et al., 1989). *P. monopterygius* is found in the southern part of the Sea of Okhotsk, off the East coast of Kamchatka and in the Bering Sea (Jordan and Gilbert, 1882; Evermann and Goldsborough, 1907; Schmidt, 1950; Matsubara, 1955; Rutenberg, 1962; Ueno, 1965; Miller and Lea, 1972).

Hexagrammos stelleri occurs off the Pacific coast of Hokkaido, in the northern part of the Sea of Japan, Sea of Okhotsk, Bering Sea, Chukchi Sea, Gulf of Alaska and off British Columbia (Jordan and Evermann, 1898; Soldatov and Lindberg, 1930; Clemens and Wilby, 1949; Schmidt, 1950; Rutenberg, 1962; Quast, 1964; Ueno, 1965; Taylor, 1967; Miller and Lea, 1972; Quast and Hall, 1972; Hart, 1973; Eschmeyer et al., 1983; Lindberg and Krasnyukova, 1987; Allen and Smith, 1988). *H. decagrammus* is known from the Aleutian Islands to northern California (Günther, 1860; Jordan and Gilbert, 1882; Jordan and Evermann, 1898; Clemens and Wilby, 1949; Follett, 1952; Rutenberg, 1962; Quast, 1964; Fitch and Lavenberg, 1971; Miller and Lea, 1972; Hart, 1973; Eschmeyer et al., 1983). *H. lagocephalus* is found off the Pacific coast of Hokkaido and the Kuril Islands, in the southern part of the Sea of Okhotsk, Bering Sea, Gulf of Alaska and off British Columbia to Point Conception, California (Jordan and Evermann, 1898; Soldatov and Lindberg, 1930; Clemens and Wilby, 1949; Schmidt, 1950; Rutenberg, 1962; Quast, 1964; Ueno, 1965; Miller and Lea, 1972; Quast and Hall, 1972; Hart, 1973; Eschmeyer et al., 1983; Lindberg and Krasnyukova, 1987; Amaoka et al., 1989). *H. octogrammus* occurs in the northern part of the Sea of Japan, off the Pacific coast of Hokkaido and the Kuril Islands, and in the Sea of Okhotsk, Bering Sea and Gulf of Alaska (Jordan and Evermann, 1898; Jordan and Starks, 1902; Soldatov and Lindberg, 1930; Schmidt, 1950; Rutenberg, 1962; Quast, 1964; Ueno, 1965; Quast and Hall, 1972; Hart, 1973; Eschmeyer et al., 1983; Lindberg and Krasnyukova, 1987; Amaoka et al., 1989). *H. otakii* is found off the Pacific coast of Japan (southern part of Hokkaido, Honshu, Shikoku, Kyushu) and in the southern part of the Sea of Japan and Yellow Sea (Jordan and Starks, 1902; Jordan and Metz, 1913; Soldatov and Lindberg, 1930; Matsubara, 1955; Rutenberg, 1962; Quast, 1964; Ueno, 1965; Kanamoto, 1976; Lindberg and Krasnyukova, 1987; Amaoka et al., 1989). *H. agrammus* is found off the southern Hokkaido, the Pacific coast of

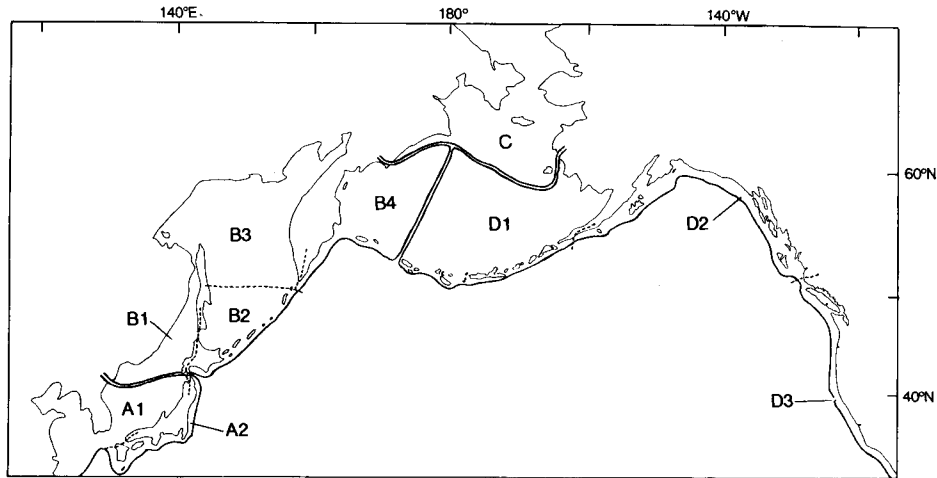

Fig. 63. Zoogeographical regions (A-D) and subregions (1-4), as defined by distributional patterns of Hexagrammoidei and Zaniolepidoidei. A, warm temperate-Japan region; B, western boreal region; C, Arctic region; D, eastern boreal region.

Honshu (Japan) and in the southern part of the Sea of Japan and Yellow Sea (Günther, 1860; Jordan and Starks, 1902; Matsubara, 1955; Rutenberg, 1962; Quast, 1964; Ueno, 1965; Kanamoto, 1976; Nelson, 1976; Lindberg and Krasnykova, 1987; Amaoka et al., 1989).

Oxylebius pictus is distributed from British Columbia to California (Rutenberg, 1962; Hart, 1973; Nelson, 1976, 1984).

Zaniolepis latipinnis is found from Vancouver Island to California (Rutenberg, 1962; Clemens and Wilby, 1949; Johnson, 1970; Hart, 1973; Eschmeyer et al., 1983). *Z. frenata* is distributed from Oregon to southern California (Rutenberg, 1962; Eschmeyer et al., 1983).

(2) Distributional patterns

The distributional pattern of each species has been defined according to zoogeographical regions of several recent investigators (Briggs, 1974; Bond, 1979; Allen and Smith, 1988). Accordingly, the distributions of the hexagrammoids and zaniolepidoids can be given as: the warm temperate-Japan, western boreal, Arctic and eastern boreal regions. These regions can be subdivided into the following subregions, based on the distributional differences of each species (Fig. 63).

The warm temperate-Japan region (region A) comprises: A1 (southern part of Sea of Japan and Yellow Sea), including *Hexagrammos otakii*, *H. agrammus* and *Pleurogrammus azonus*; and A2 (Pacific coast of Honshu, Shikoku and Kyushu), including *H. otakii* and *H. agrammus*.

The western boreal region (region B) comprises: B1 (northern part of Sea of Japan), including *H. stelleri*, *H. octogrammus* and *P. azonus*; B2 (southern part of Sea of Okhotsk, Kuril Islands and Pacific coast of Hokkaido), including *H. lagocephalus*, *H. stelleri*, *H. octogrammus*, *P. azonus* and *P. monopterygius*; B3 (northern part of Sea of Okhotsk), including *H. stelleri* and *H. octogrammus*; and B4 (south-

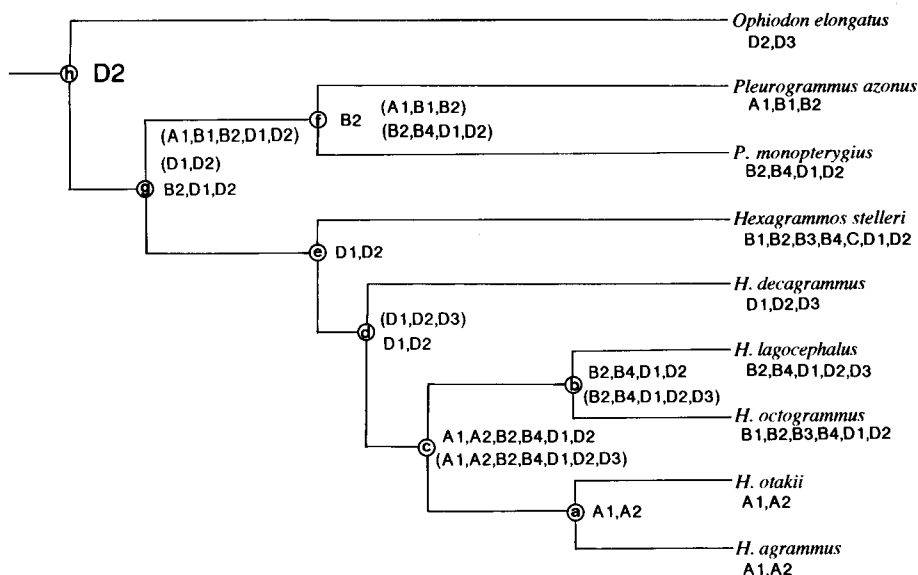

Fig. 64. Relationships between branching pattern and distribution of each species in Hexagrammoidei. Cases including ancestral species are shown in parentheses.

western part of Bering Sea and adjacent waters), including *H. lagocephalus*, *H. octogrammus*, *H. stelleri* and *P. monoptygius*.

The Arctic region (region C) includes a single species, *Hexagrammos stelleri*.

The eastern boreal region (region D) comprises : D1 (southeastern part of Bering Sea), including *H. lagocephalus*, *H. decagrammus*, *H. stelleri*, *H. octogrammus* and *P. monoptygius* ; D2 (Gulf of Alaska), including *H. lagocephalus*, *H. decagrammus*, *H. stelleri*, *H. octogrammus*, *P. monoptygius* and *Ophiodon elongatus* ; and D3 (Pacific coast from British Columbia to California), including *H. lagocephalus*, *H. decagrammus*, *O. elongatus*, *Oxylebius pictus*, *Zaniolepis latipinnis* and *Z. frenata*.

(3) Origin of the suborders (Fig. 64)

The center of origin of each suborder is proposed following the zoogeographic method of Sawada (1982). Under the premise that neither species is an ancestor of the other, the branching pattern of the cladogram suggests that the common ancestor of *H. otakii* and *H. agrammus* (node a in Fig. 64) existed in subregions A1 and A2 ; similarly, that of *H. octogrammus* and *H. lagocephalus* (node b) in subregions B2, B4, D1 and D2. The distribution of the ancestor of the four above-mentioned species (node c) is deduced to have been in subregions A1, A2, B2, B4, D1 and D2. The ancestor of all *Hexagrammos* species, except *H. stelleri*, (node d) is thought to have existed in subregions D1 and D2, and the common ancestor of the entire genus (node e) in subregions D1 and D2. Two species of *Pleurogrammus* (*P. azonus* and *P. monoptygius*) have a common ancestor (node f) thought to have existed in subregion B2, with the common ancestor of *Hexagrammos* and *Pleurogrammus* (node g), being estimated as having existed in subregions B2, D1 and D2. Since the

monotypic genus, *Ophiodon*, occupies subregions D2 and D3, the common ancestor of the three genera, *Hexagrammos*, *Pleurogrammus* and *Ophiodon*, (node h) is deduced to have existed in subregion D2.

Should some of the extant species be in fact ancestral to the others, the following estimations of their origin can be made. If *H. lagocephalus* is ancestral to *H. octogrammus*, the distribution of the ancestors (node b) and (node c) should have been in subregions B2, B4, D1, D2 and D3 (= distribution of *H. lagocephalus*), and A1, A2, B2, B4, D1, D2 and D3, respectively. If *H. decagrammus* is the common ancestor of the other species, except *H. stelleri* (node d), it is thought to have occurred in subregions D1, D2 and D3. In the above cases, however, the distribution of the common ancestor of all *Hexagrammos* species (node e) is thought to have been in subregions D1 and D2. In the case of a *Pleurogrammus* species being ancestral to the other, the ancestor (node f) is thought to have existed in subregions A1, B1 and B2, or B2, B4, D1 and D2. Although the distribution of the immediate ancestor (node f) would have been influenced by that of a preceding form (node g), the common ancestor of all three genera (node h) is believed to have existed in subregion D2.

Consequently, the origin of the suborder Hexagrammoidei is believed to have occurred in the Gulf of Alaska and adjacent areas.

On the other hand, the zaniolepidoids are distributed in subregion D3, although there are small differences occur between the species. The suborder is thought to have originated off the North American coast from British Columbia to California.

(4) Dispersal of suborder Hexagrammoidei

From the supposed origin of the suborder in or near the Gulf of Alaska (D2), it is thought that *Ophiodon elongatus* moved southward along the Pacific coast of North America, while *Pleurogrammus* moved westward. Three dispersal patterns are believed applicable to *Hexagrammos*. The first, the southward dispersal to subregion D3, is supported by the present distribution of *H. decagrammus*. The second and third are northward and westward dispersals, respectively, supported by the present distribution of *H. stelleri*.

The distribution of *Pleurogrammus azonus* is restricted to the western North Pacific, slightly overlapping that of *P. monopterygius*. In addition, the distributions of *Hexagrammos agrammus* and *H. otakii* are restricted to the southwestern region of the North Pacific, being discrete from those of *H. octogrammus* and *H. lagocephalus*. These distributional patterns suggest that evolutionary events such as parapatric or allopatric speciation occurred in *Pleurogrammus* and *Hexagrammos*. If allopatric speciation (vicariance) in fact took place, it may have occurred during the several glacial periods from the late Tertiary to the Quaternary, owing to the isolation of some areas of the western boreal region at this time (Briggs, 1974).

3. Phylogenetic evidence from other characters

(1) Fusion of caudal elements

The character phylogeny of caudal skeleton fusions was estimated according to the interrelationships of a monophyletic group comprising the anoplomatoids, zaniolepidoids, hexagrammoids and cottoids. As mentioned previously, all caudal elements, such as the first to fifth hypurals, parhypural and haemal spines of the two

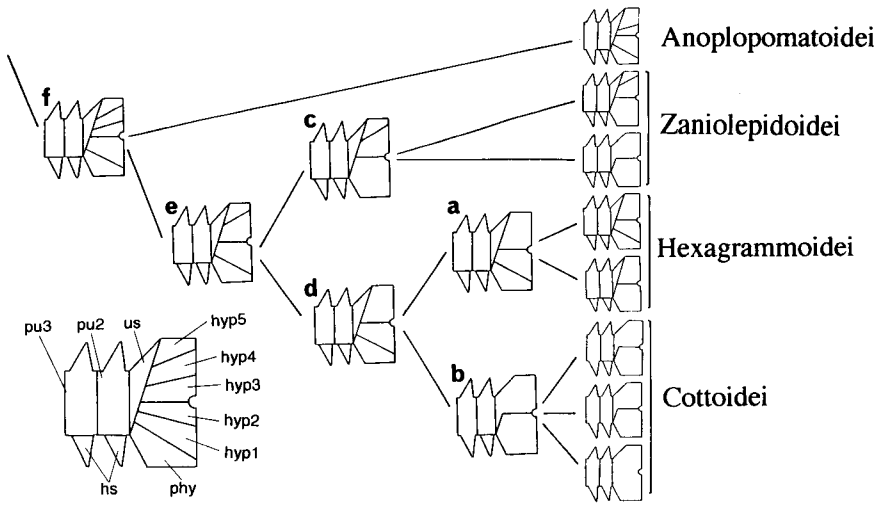
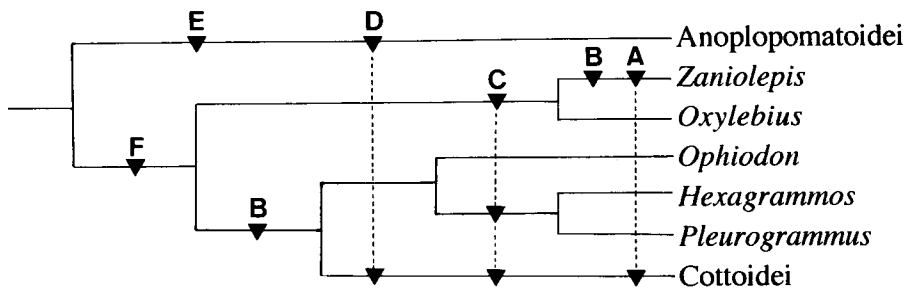

Fig. 65. Character phylogeny of caudal skeleton. a-f, putative ancestral conditions.

preural centra, are thought to be separate from each other in the ancestor of the Scorpaeniformes. For example, the common ancestral condition of the hexagrammoids is considered to have been the same as that of *Ophiodon* (condition a in Fig. 65). In the same way, the ancestral conditions of each taxon can be inferred simply (conditions b-f in Fig. 65). The ancestor of the four suborders is believed to have had the same condition as that of the scorpaeniform ancestor except for having the



- A: Urostyle (us) fused to hypural complex (hyp3+hyp4+hyp5)
- B: Hypural complex (hyp3+hyp4) fused to 5th hypural (hyp5)
- C: Parhypural (phy) fused to hypural complex (hyp1+hyp2)
- D: Third preural centrum (pu3) fused to haemal spine (hs)
- E: Fourth hypural (hyp4) fused to 5th hypural (hyp5)
- F: Third hypural (hyp3) fused to 4th hypural (hyp4)

Fig. 66. Distributions of apomorphic characters (A-F) in monophyletic group comprising Anoplopomatoidei, Zanioleptoidei, Hexagrammoidei and Cottoidei.

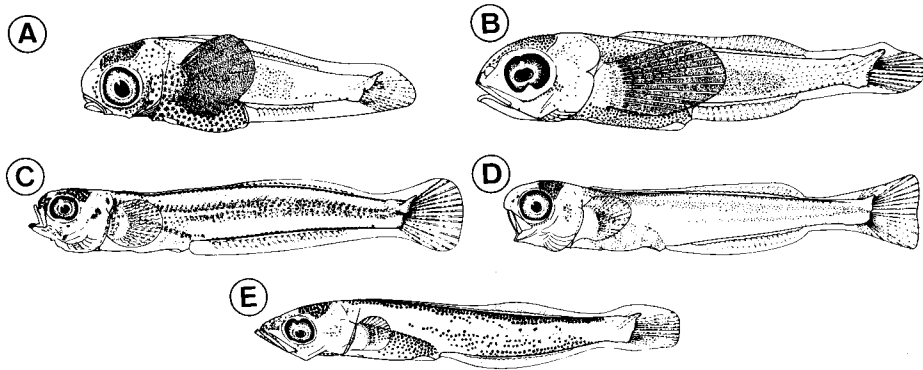

Fig. 67. Larvae of Zanioleptoidei (A, B) and Hexagrammoidei (C-E) (taken from Kendall and Vinter, 1984). A, *Oxylebius pictus*; B, *Zaniolepis* sp.; C, *Hexagrammos octogrammus*; D, *Pleurogrammus monoptyerygius*; E, *Ophiodon elongatus*.

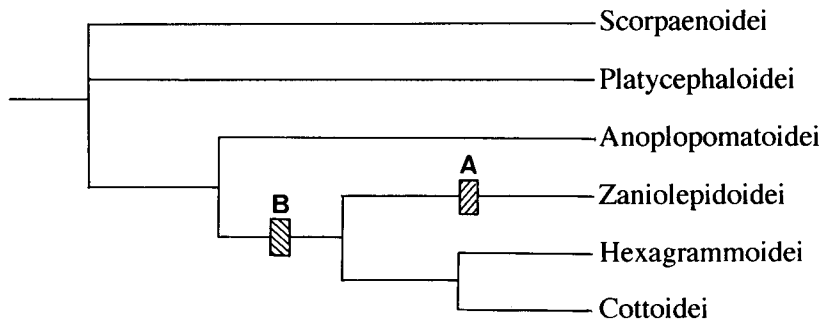

Fig. 68. Distributions of two putative synapomorphies of larvae (A) and eggs (B).

first hypural fused to the second. Accordingly, six derived characters can be traced (Fig. 66A-F). For example, the monophyly of three suborders, Zanioleptoidei, Hexagrammoidei and Cottoidei, is further supported by a synapomorphy, the third hypural being fused to the fourth (Character F in Fig. 66). In addition, the Zanioleptoidei is further defined by one synapomorphy, as is the monophyly of Hexagrammoidei and Cottoidei (Fig. 66).

(2) Larval and egg characters

According to Kendall and Vinter (1984), both *Oxylebius* and *Zaniolepis* have large, pigmented pectoral fin during their larval stage (Fig. 67A, B). Since this character is rare in the scorpaeniform and percoid larvae (Johnson, 1984; Washington et al., 1984b; Matarese et al., 1989), it is suspected to be a synapomorphy of the suborder Zanioleptoidei (Character A in Fig. 68).

Three suborders, Zanioleptoidei, Hexagrammoidei and Cottoidei, excepting the comephorids, are known to spawn adhesive, demersal eggs (Washington et al., 1984b). On the other hand, the suborders Scorpaenoidei, Platycephaloidei and

Anoplopomatoidei spawn pelagic eggs, although some members of the scorpaenid, *Sebastes* are viviparous (Washington et al., 1984b; Matarese et al., 1989). Since most berycoids and percoids are thought to spawn pelagic eggs (Breder and Rosen, 1966; Johnson, 1984), the spawning of demersal eggs may be a synapomorphy of the Zaniolepidoidae, Hexagrammoidei and Cottoidei (Character B in Fig. 68).

XII. Summary

The present study was made in order to clarify the phylogeny of the hexagrammoids and related taxa, and to establish a natural classification system based on phylogenetic considerations. For the analysis of phylogenetic relationships, the cladistic approach was adopted. Initially, morphological characters, including osteological, myological and nervous system features of all hexagrammoid and 36 other scorpaeniform genera were investigated. The polarity of each character was determined by comparison with basal acanthopterygians, fifty-three characters being selected and used for estimating relationships. Secondly, morphological variations of all of the species belonging to *Hexagrammos* were examined, 10 characters being used for inference of their relationships. The polarity of each character was determined by outgroup comparison. The dispersal route of each hexagrammoid species was proposed on the basis of present distributions. The synapomorphic value of some further characters was examined by reference to the reconstructed phylogeny.

The conclusions of the study are summarized below.

1. Hexagrammoids, as defined and treated by previous workers, are paraphyletic, being included in two different phylogenetic groups, the first comprising *Zaniolepis* and *Oxylebius*, and the second *Hexagrammos*, *Pleurogrammus* and *Ophiodon*. The first group is a sister group of the second plus the cottoidei. *Hexagrammos*, *Pleurogrammus* and *Ophiodon* form a sister group of the cottoidei. *Hexagrammos* is closer phylogenetically to *Pleurogrammus* than *Ophiodon*.

2. A new classification was proposed on the basis of phylogenetic relationships. A new suborder, Zaniolepidoidae, was established for two genera, *Zaniolepis* and *Oxylebius*, in the family Zaniolepididae. Three genera, *Hexagrammos*, *Pleurogrammus* and *Ophiodon*, were combined under the suborder Hexagrammoidei and family Hexagrammidae.

3. Within *Hexagrammos*, *H. stelleri* diverged first, followed by *H. decagrammus*. *H. octogrammus* is a sister group of *H. lagocephalus*, and *H. agrammus* of *H. otakii*.

4. The center of origin of the Hexagrammoidei is considered to be the Gulf of Alaska. The Zaniolepidoidae is considered to have originated from the waters off British Columbia to California.

5. Some caudal fin osteological characters were elucidated in support of the present phylogeny. The monophyly of the Zaniolepidoidae is further supported by a larval character. The spawning of demersal eggs is judged as a putative synapomorphy of three suborders, Zaniolepidoidae, Hexagrammoidei and Cottoidei.

XIII. References

- Ahlstrom, E.C. and Moser, H.G. (1976). Eggs and larvae of fishes and their role in systematic investigations and in fisheries. *Rev. Trav. Inst. Peches. Marit.* **40**, 379-398.
- Allen, M.J. and Smith, G.B. (1988). Atlas and zoogeography of common fishes in the Bering Sea and northeastern Pacific. *NOAA Tech. Rep. NMFS* **66**, 1-151.
- Amaoka, K., Nakaya, K. and Yabe, M. (1989). Fishes of Usujiri and adjacent waters in southern Hokkaido, Japan. *Bull. Fac. Fish. Hokkaido Univ.* **40**, 245-277.
- Anderson, M.E. (1982). Revision of the fish genera *Gymnelus reinhardt* and *Gymnelopsis soldatov* (Zoaridae), with two new species and comparative osteology of *Gymnelus viridis*. *Natn. Mus. Can. Publ. Zool.* (17), i-iv + 1-76.
- Archie, J.N. (1985). Methods for coding variable morphological features for numerical taxonomic analysis. *Syst. Zool.* **43**, 326-345.
- Berg, L.S. (1940). Classification of fishes, both recent and fossil. *Trudy Zool. Inst. Leningrad* **5**, 87-517.
- Bond, C.E. (1979). *Biology of Fishes*. vii+514 p. Saunder Coll. Publ., Philadelphia.
- Breder, C.N., Jr. and Rosen, D.E. (1966). *Modes of Reproduction in Fishes*. xv+941 p. Amer. Mus. Natl. Hist., New York.
- Briggs, J.C. (1974). *Marine Zoogeography*. xi+461 p. McGraw-Hill, New York.
- Clemens, W.A. and Wilby, C.V. (1949). Fishes of the Pacific coast of Canada. *Bull. Fish. Res. Bd. Can.* **68**, 1-368.
- Crisci, J.V. and Stuessy, T.F. (1980). Determining primitive character state for phylogenetic reconstruction. *Syst. Bot.* **5**, 112-135.
- Elshold-Oldenhave, M.J.W. and Osse, J.W.M. (1976). Functional morphology of the feeding system in the ruff-*Gymnocephalus cernua* (L. 1758)-(Teleostei, Percidae). *J. Morph.* **150**, 399-422.
- Eschmeyer, W.N. (1965). Western Atlantic scorpionfishes of the genus *Scorpaena*, including four new species. *Bull. Mar. Sci.* **15**, 84-164.
- Eschmeyer, W.N. (1969). A systematic review of the scorpionfishes of the Atlantic Ocean (Pisces : Scorpaenidae). *Occas. Pap. Calif. Acad. Sci.* **79**, 1-143.
- Eschmeyer, W.N., Hallacher, L.E. and Rama-Rao, K.V. (1979). The scorpionfish genus *Minous* (Scorpaenidae, Minoinae) including a new species from the Indian Ocean. *Proc. Calif. Acad. Sci.* **41**, 453-473.
- Eschmeyer, W.N., Herald, E.S. and Hammann, H. (1983). *A Field Guide to Pacific Coast Fishes of North America*. xii+336 p. Houghton Mifflin Company, Boston.
- Eschmeyer, W.N., Hirosaki, Y. and Abe, T. (1973). Two new species of the scorpionfish genus *Rhinopias*, with comments on related genera and species. *Proc. Calif. Acad. Sci.* **39**, 285-310.
- Eschmeyer, W.N. and Rama-Rao, K.V. (1973). Two new stonefishes (Pisces, Scorpaenidae) from the Indo-West Pacific, with a synopsis of the subfamily Synanceiidae. *Proc. Calif. Acad. Sci.* **39**, 337-382.
- Evermann, B.W. and Goldsborough, E.L. (1907). The fishes of Alaska. *Bull. U.S. Bur. Fish.* **26**, i-viii+221-360, pls. 14-42.
- Fitch, J.E. and Lavenberg, R.J. (1971). *Marine Food and Game Fishes of California*. 179 p. Univ. Calif. Press, Berkeley.
- Follett, W.I. (1952). Annotated list of fishes obtained by the California Academy of Sciences during six cruises of the U.S.S. Mulberry conducted by the United States Navy off central California in 1949 and 1950. *Proc. Calif. Acad. Sci.* **27**, 399-432.
- Fraser, T.H. (1968). Comparative osteology of the Atlantic snooks (Pisces, *Centropomus*). *Copeia* **1968**, 433-460.
- Fraser, T.H. (1972). Comparative osteology of the shallow water cardinal fishes [Perciformes : Apogonidae] with reference to the systematics and evolution of the family. *Ichthyol. Bull. Rhodes Univ.* (34), 1-105, pls. 1-44.
- Freihofer, W.C. (1963). Patterns of the ramus lateralis accessorius and their systematic significance in teleostean fishes. *Stanford Ichthyol. Bull.* **8**, 80-189.
- Freihofer, W.C. (1978). Cranial nerves of a percoid fish, *Polycentrus schomburgkii* (family Nan-didae), a contribution to the morphology and classification of the order Perciformes. *Occas.*

- Pap. Calif. Acad. Sci.* (128), i-iii+1-78.
- Fujita, K. (1990). *The Caudal Skeleton of Teleostean Fishes*. xiii+897 p. Tokai Univ. Press, Tokyo. (In Japanese with English summary).
- Gill, T. (1889). On the classification of the mail-cheeked fishes. *Proc. U.S. Natn. Mus.* 11, 567-592.
- Goldman, N. (1988). Methods for discrete coding of morphological characters for numerical analysis. *Cladistics* 4, 59-71.
- Gosline, W.A. (1968). The suborder of perciform fishes. *Proc. U.S. Natn. Mus.* 124, 1-78.
- Gosline, W.A. (1971). *Functional Morphology and Classification of Teleostean Fishes*. ix+208 p. Univ. Press Hawaii, Honolulu.
- Greenwood, P.H., Rosen, D.E., Weitzman, S.H. and Myers, G.S. (1966). Phyletic studies of teleostean fishes, with a provisional classification of living forms. *Bull. Amer. Mus. Natl. Hist.* 131, 339-456.
- Gregory, W.K. (1933). Fish skulls: study of the evolution of natural mechanisms. *Trans. Amer. Phil. Soc.* (new series) 23, 75-481.
- Günther, A. (1860). *Catalogue of the Fishes in the British Museum. II.* xxi+548 p. Taylor & Francis, London.
- Hallacher, L.E. (1974). The comparative morphology of the extrinsic gasbladder musculature in the scorpionfish genus *Sebastes* (Pisces: Scorpaenidae). *Proc. Calif. Acad. Sci.* 15, 59-84.
- Hart, J.L. (1973). Pacific fishes of Canada. *Bull. Fish. Res. Bd. Can.* 180, 1-740.
- Hazlett, B. and Winn, H.E. (1962). Sound producing mechanism of the nassau grouper, *Epinephelus striatus*. *Copeia* 1962, 447-449.
- Hennig, W. (1966). *Phylogenetic Systematics*. 263 p. Univ. Illinois Press, Urbana.
- Hotta, H. (1961). *Comparative Study of the Axial Skeleton of Japanese Teleostei*. 153 p., 70 pls. Nippon Gyogaku Shinkokai, Tokyo. (In Japanese with English abstract).
- Johnson, C.R. (1970). Biology of *Zaniolepis latipinnis* (Zaniolepididae) in relation to vertical distribution. *Copeia* 1970, 769-771.
- Johnson, G.D. (1980). The limits and relationships of the Lutjanidae and associated families. *Bull. Scripps Inst. Oceanogr. Univ. Calif.* 24, 1-114.
- Johnson, G.D. (1983). *Nippon spinosus*: a primitive epinepheline serranid, with comments on the monophyly and interrelationships of the Serranidae. *Copeia* 1983, 777-787.
- Johnson, G.D. (1984). Percoidae: development and relationships. p. 464-498. In Moser, H.G., Richards, W.J., Cohen, D.M., Fahay, M.P., Kendall, A.W., Jr. and Richardson, S.L. (eds.), *Ontogeny and Systematics of Fishes* ix+760 p. A.S.I.H. Spec. Publ. (1), Lawrence.
- Johnson, G.D. (1986). Scombrid phylogeny: an alternative hypothesis. *Bull. Mar. Sci.* 39, 1-41.
- Johnson, G.D. and Fritzsche, R.A. (1989). *Graus nigra*, an omnivorous girellid, with a comparative osteology and comments on relationships of the Girellidae (Pisces: Perciformes). *Proc. Acad. Natl. Sci. Philadelphia* 141, 1-27.
- Johnson, G.D. and Rosenblatt, R.H. (1988). Mechanism of light organ occlusion in flashlight fishes, family Anomalopidae (Teleostei: Beryciformes), and the evolution of the group. *Zool. J. Linn. Soc.* 94, 65-96.
- Jordan, D.S. (1923). A classification of fishes including families and genera as far as known. *Stanford Univ. Publ. Univ. Ser. Biol. Sci.* 3, i-x+7-243.
- Jordan, D.S. and Evermann, B.W. (1898). The fishes of North and Middle America, Part 2. *Bull. U.S. Natn. Mus.* (47), 1241-2183.
- Jordan, D.S. and Gilbert, C.H. (1882). *Synopsis of the Fishes of North America*. 642 p. Wash. Government Print. Office, Washington.
- Jordan, D.S. and Metz, C.W. (1913). A catalog of the fishes known from the waters of Korea. *Mem. Carnegie Mus.* 6, 1-65, pls. 1-10.
- Jordan, D.S. and Starks, E.C. (1902). A review of fishes of Japan belonging to the family Hexagrammidae. *Proc. U.S. Natn. Mus.* 26, 1003-1013.
- Kanamoto, Z. (1976). On the ecology of the hexagrammid fish: I. habitats and behaviors of *Agrammus agrammus* (Temminck et Schlegel) and *Hexagrammos otakii* (Jordan et Starks). *Japan. J. Ecol.* 26, 1-12. (In Japanese with English abstract).
- Kanayama, T. (1991). Taxonomy and phylogeny of the family Agonidae (Pisces: Scorpaeniformes). *Mem. Fac. Fish. Hokkaido Univ.* 38, 1-199.
- Katayama, M. (1956). On the external and internal characters of *Lates calcarifer* (Bloch), with its

- systematic position. *Bull. Fac. Edu. Yamaguchi Univ.* **6**, 133-140.
- Katayama, M. (1959). Study on the serranid fishes of Japan (I). *Ibid.* **8**, 103-180.
- Katayama, M. (1960). *Ditto* (II). *Ibid.* **9**, 63-98.
- Keene, M.J. and Tighe, K.A. (1984). Beryciformes: development and relationships. p. 383-392. In Moser, H.G., Richards, W.J., Cohen, D.M., Fahay, M.P., Kendall, A.W., Jr. and Richardson, S.L. (eds.), *Ontogeny and Systematics of Fishes* ix+760 p. A.S.I.H. Spec. Publ. (1), Lawrence.
- Kendall, A.W., Jr. and Vinter, B. (1984). Development of hexagrammids (Pisces: Scorpaeniformes) in the Pacific Ocean. *NOAA Tech. Rep. NMFS* **2**, i-iii+1-44.
- Kido, K. (1988). Phylogeny of the family Liparididae, with the taxonomy of the species found around Japan. *Mem. Fac. Fish. Hokkaido Univ.* **35**, 125-256.
- Kusaka, T. (1974). *The Urohyal of Fishes*. xiv+320 p. Univ. Tokyo Press, Tokyo.
- Lauder, G.V. (1983). Functional and morphological bases of trophic specialization in sunfishes (Teleostei, Centrarchidae). *J. Morph.* **178**, 1-21.
- Lauder, G.V. and Liem, K.L. (1983). The evolution and interrelationships of the actinopterygian fishes. *Bull. Mus. Comp. Zool.* **150**, 95-197.
- Leviton, A.E., Gibbs, R.H., Jr., Heal, E. and Dawson, C.E. (1985). Standards in herpetology and ichthyology: part I. standard symbolic codes for institutional resource collections in herpetology and ichthyology. *Copeia* **1985**, 802-832.
- Liem, K.F. (1970). Comparative functional anatomy of the Nandidae (Pisces: Teleostei). *Fieldiana Zool.* **56**, 1-166.
- Lindberg, G.U. (1971). *Fishes of the World: a key to families and a checklist*. (Translated from the Russian by Hardin, H., 1974), v+545 p. John Wiley & Sons, New York.
- Lindberg, G.U. and Krasnyukova, Z.V. (1987). *Fishes of the Sea of Japan and the Adjacent Areas of the Sea of Okhotsk and the Yellow Sea, Part 5: Scorpaeniformes*. 524 p. Nauka SSSR, Leningrad. (In Russian).
- Maddison, W.P., Donoghue, M.J. and Maddison, D.R. (1984). Outgroup analysis and parsimony. *Syst. Zool.* **33**, 83-103.
- Makushok, V.M. (1958). The morphology and classification of the northern blennioid fishes (Stichaeoidea, Blennioidei, Pisces). *Trudy Zool. Inst. Oceanol. Akad. Sci. USSR* **43**, 225-269. (In Russian).
- Mandrytza, S.A. (1990). The construction of the musculus adductor mandibulae of the scorpaeniform fishes. *USSR Acad. Sci. Proc. Zool. Inst. Leningrad* **222**, 75-93. (In Russian with English summary).
- Masuda, H., Amaoka, K., Araga, C., Uyeno, T. and Yoshino, T. (1984). *The Fishes of the Japanese Archipelago*. English text. xx+473 p. Tokai Univ. Press, Tokyo.
- Matarese, A.C., Kendall, A.W., Jr., Blood, D.M. and Vinter, B.M. (1989). Laboratory guide to early life history stages of North Pacific fishes. *NOAA Tech. Rep. NMFS* **80**, i-iv+1-652.
- Matsubara, K. (1943a). Studies on the scorpaenoid fishes of Japan: anatomy, phylogeny and taxonomy (I). *Trans. Shigenkagaku Kenkyusho* (1), 1-170.
- Matsubara, K. (1943b). *Ditto* (II). *Ibid.* (2), 171-486, pls. 1-4.
- Matsubara, K. (1955). *Fish Morphology and Hierarchy*. xii+1605 p., 135 pls. Ishizaki Shoten, Tokyo. (In Japanese).
- Matsubara, K. and Ochiai, A. (1955). A revision of the Japanese fishes of the family Platycephalidae (the flatheads). *Mem. Coll. Agr. Kyoto Univ.* (68), 1-109, pls. 1-3.
- McAllister, D.E. (1968). Evolution of branchiostegals and associated opercular, gular, and hyoid bones and classification of teleostome fishes, living and fossil. *Natn. Mus. Can. Bull.* (211), i-xiv+1-239, pls. 1-21.
- Miller, D.J. and Lea, R.N. (1972). Guide to the coastal marine fishes of California. *Calif. Dep. Fish & Game, Fish. Bull.* (157), 1-249.
- Monod, T. (1968). Le complexe urophore des poissons téléostéens. *Mem. Inst. Fondam. Afr. Noire* (81), i-vi+1-705. (In French).
- Nelson, G. (1974). Classification as an expression of phylogenetic relationships. *Syst. Zool.* **22**, 344-359.
- Nelson, J.S. (1976). *Fishes of the World*. xiii+373 p. John Wiley & Sons, New York.
- Nelson, J.S. (1984). *Ditto*. 2nd Ed. xv+475 p. John Wiley & Sons, New York.

- Nursall, J.R. (1963). The caudal musculature of *Haplopagrus guntheri* Gill (Perciformes: Lutjanidae). *Can. J. Zool.* **41**, 865-880.
- Okada, Y. and Suzuki, K. (1954). The osteological study of the genus *Malakichthys*. *Rep. Fac. Fish. Pref. Univ. Mie* **1**, 229-238.
- Osse, J.W.M. (1969). Functional morphology of the head of the perch (*Perca fluviatilis* L.): an electromyographic study. *Neth. J. Zool.* **19**, 289-392.
- Patterson, C. (1964). A review of Mesozoic acanthopterygian fishes, with special reference to those of the English Chalk. *Phil. Trans. Roy. Soc. ser. 2*, **247**, 213-482, pls. 2-5.
- Quast, J.C. (1964). Meristic variation in the hexagrammid fishes. *Fish. Bull.* **63**, 589-609.
- Quast, J.C. (1965). Osteological characteristics and affinities of the hexagrammid fishes with a synopsis. *Proc. Calif. Acad. Sci.* **31**, 563-600.
- Quast, J.C. and Hall, E.L. (1972). List of fishes of Alaska and adjacent waters with a guide to some their literature. *NOAA Tech. Rep. NMFS. SSRF Circ.* (685), i-iv+1-47.
- Ray, D.L. (1950). The peripheral nervous system of *Lampanyctus leucopsarus*. *J. Morph.* **87**, 61-178.
- Regan, C.T. (1913). The osteology and classification of the teleostean fishes of the order Scleroparei. *Ann. Mag. Natl. Hist.* **8**, 169-184.
- Rosen, D.E. (1973). Interrelationships of higher euteleostean fishes. p. 397-513. In Greenwood, P.H., Miles, R.S. and Patterson, C. (eds.), *Interrelationships of Fishes* xvi+536 p. *Zool. J. Linn. Soc.* **53**, (Suppl. 1). Acad. Press, London.
- Rutenberg, E.P. (1962). Survey of the fishes of family Hexagrammidae. p. 1-103. In Rass, T.S. (ed.), *Greenlings: taxonomy, biology, interoceanic transplantation* (Translated from the Russian by Raveth, M., 1970), iv+208 p. *Isr. Program Sci. Transl.*, Jerusalem.
- Rybachuk, V.K. (1976). Features of structure of the skeleton and caudal fin muscles in *Sebastes nebulosus* and *Sebastes jordani* (Scorpaenidae). *J. Ichthyol.* **19**, 92-101.
- Sasaki, K. (1989). Phylogeny of the family Sciaenidae, with notes on its zoogeography (Teleostei, Perciformes). *Mem. Fac. Fish. Hokkaido Univ.* **36**, 1-137.
- Sawada, Y. (1982). Phylogeny and zoogeography of the superfamily Cobitoidea (Cyprinoidei, Cypriniformes). *Mem. Fac. Fish. Hokkaido Univ.* **28**, 65-223.
- Schmidt, P.Y. (1950). *Fishes of the Sea of Okhotsk*. (Translated from the Russian by Ronen, O., 1965), 370 p., 20 pls. *Isr. Program Sci. Transl.*, Jerusalem.
- Schultz, L.P. and DeLacy, A.C. (1935-1936). Fishes of the American Northwest: a catalogue of the fishes of Washington and Oregon, with distributional record and a bibliography. *Mid-Pac. Mag.* **1935**, 365-380; **1936**, 63-78, 127-142, 211-226, 275-290.
- Smith, C.L. and Bailey, R.M. (1962). The subocular shelf of fishes. *J. Morph.* **110**, 1-17.
- Smith-Vanitz, W.F. and Johnson, G.D. (1990). Two new species of Acanthoclininae (Pisces: Plesiopidae) with a synopsis and phylogeny of the subfamily. *Proc. Acad. Natl. Sci. Philadelphia* **142**, 211-260.
- Sokal, R.R. and Rohlf, F.J. (1981). Taxonomic congruence in the Leptopodomorpha reexamined. *Syst. Zool.* **30**, 309-325.
- Soldatov, V.K. and Lindberg, G.J. (1930). A review of the fishes of the sea of the Far East. *Bull. Pac. Sci. Fish. Inst.* **5**, 1-576. (In Russian with English summary).
- Springer, V.G. and Freihof, W.C. (1978). Study of the monotypic fish family Pholidichthyidae (Perciformes). *Smithsonian Contrib. Zool.* **216**, 1-43.
- Starks, E.C. (1903). The osteology of some berycoid fishes. *Proc. U.S. Natn. Mus.* **27**, 601-619.
- Swofford, D.L. (1991). *PAUP: phylogenetic analysis using parsimony*. Version 3.0s. Illinois Natl. Hist. Survey, Champaign.
- Taylor, F.H.C. (1967). Midwater trawl catches from Queen Charlotte Islands. *Fish. Res. Bd. Can. Tech. Rep.* (11), 1-44.
- Tominaga, Y. (1968). Internal morphology, mutual relationships and systematic positions of the fishes belonging to the family Pempheridae. *Japan. J. Ichthyol.* **15**, 43-95.
- Ueno, T. (1965). Fishes of the adjacent waters of Hokkaido: 3. hexagrammid fishes. *Hoksuishigeppo Rep. Hokkaido Fish. St.* **22**, 108-116. (In Japanese).
- Ueno, T. (1970). *Fauna Japonica: Cyclopteridae (Pisces)*. 233 p., 13 pls. Acad. Press Japan, Tokyo.
- Vandewalle, P., Havard, M., Claes, G. and de Vree, F. (1992). Mouvements des mâchoires pharyn-

- giennes pendant la prise de nourriture chez le *Serranus scriba* (Linne, 1758) (Pisces, Serranidae). *Can. J. Zool.* **70**, 145-160. (In French with English abstract).
- Vari, R.P. (1978). The terapon perches (Percoidae, Teraponidae): a cladistic analysis and taxonomic revision. *Bull. Amer. Mus. Nat. Hist.* **159**, 175-340.
- Wainwright, P.C. (1989). Functional morphology of the pharyngeal jaw apparatus in perciform fishes: an experimental analysis of the Haemulidae. *J. Morph.* **200**, 231-245.
- Washington, B.B., Eschmeyer, W.N. and Howe, K.M. (1984a). Scorpaeniformes: relationships. p. 438-447. In Moser, H.G., Richards, W.J., Cohen, D.M., Fahay, M.P., Kendall, A.W., Jr. and Richardson, S.L. (eds.), *Ontogeny and Systematics of Fishes* ix+760 p. A.S.I.H. Spec. Publ. (1), Lawrence.
- Washington, B.B., Moser, H.G., Laroche, W.A. and Richards, W.J. (1984b). Scorpaeniformes: development. p. 405-428. *Ibid.*
- Watanabe, M. (1958). *Studies on the Sculpin of Japan and its Adjacent Waters*. 461 p., 124 pls. Kadokawa Shoten, Tokyo. (In Japanese).
- Watrous, L.E. and Wheeler, Q.D. (1981). The out-group comparison method of character analysis. *Syst. Zool.* **30**, 1-11.
- Wiley, E.O. (1981). *Phylogenetics: the theory and practice of phylogenetic systematics*. xv+439 p. John Wiley & Sons, New York.
- Wiley, E.O., Siegel-Causey, D., Brooks, D.R. and Funk, V.A. (1991). *The Compleat Cladist: a primer of phylogenetic procedures*. x+158 p. Univ. Kansas Mus. Natl. Hist. Spec. Publ. (19), Lawrence.
- Winterbottom, R. (1974). A descriptive synonymy of the striated muscles of the Teleostei. *Proc. Acad. Natl. Sci. Philadelphia* **125**, 225-317.
- Woods, L.P. and Sonoda, P.M. (1973). Order Berycomorphi (Beryciformes). p. 263-396. In Cohen, D.M., Atz, J.W., Gibbs, R.H., Berry, F.H., Lachner, E.A., Böhlke, J.E. and Mead, G.W. (eds.), *Fishes of the Western North Atlantic* xix+698 p. Mem. Sears Found. Mar. Res. Yale Univ. (1) (part 6), New Haven.
- Yabe, M. (1985). Comparative osteology and myology of the superfamily Cottoidea (Pisces: Scorpaeniformes), and its phylogenetic classification. *Mem. Fac. Fish. Hokkaido Univ.* **32**, 1-130.
- Yatsu, A. (1986). Phylogeny and zoogeography of the subfamilies Xiphisterinae and Cebidichthyinae (Blennioidei, Stichaeidae). p. 663-678. In Uyeno, T., Arai, R., Taniuchi, T. and Matsuura, K. (eds.), *Indo-Pacific Fish Biology: proceeding of the second international conference on Indo-Pacific fishes* xii+985 p. Ichthyol. Soc. Japan, Tokyo.
- Yusa, T. (1967). Embryonic development and larvae of the atka mackerel, *Pleurogrammus azonus* Jordan et Metz. *Sci. Rep. Tohoku Univ.* Ser. IV (Biol.) **33**, 301-318.
- Zehren, S.J. (1979). *The Comparative Osteology and Phylogeny of the Beryciformes (Pisces: Teleostei)*. ii+389 p. Evol. Monogr. Univ. Chicago, Chicago.

XIV. Appendix

Character conditions (A, B) of the Berycoidei and Percoidae, which are found in the Scorpaeniformes, including the "Hexagrammoidei", are shown in Table 8.

Character 1 [Primary tubules on first infraorbital: A, absent; B, present]

All berycoids and percoids examined here had condition A, the same condition having been widely found in other berycoids and percoids (Katayama, 1956, 1959; Fraser, 1968, 1972; Tominaga, 1968; Zehren, 1979; Sasaki, 1989). Basal acanthopterygians may have lacked primary tubules on the first infraorbital bone.

Character 2 [Attachment of dermosphenotic to sphenotic: A, firm; B, loose]

All berycoids and percoids examined here had condition A. Although the character has been given little attention in other berycoids and percoids, condition A has also been found in the Sciaenidae (Sasaki, 1989). The dermosphenotic may have been firmly attached to the sphenotic in basal acanthopterygians.

Character 3 [Suborbital shelf: A, present; B, absent]

All berycoids and percoids examined here had condition A. According to Zehren (1979), the beryciforms usually possess a suborbital shelf. The same condition has been reported from many other percoids (Katayama, 1956, 1959; Fraser, 1968, 1972; Tominaga, 1968; Sasaki, 1989). Therefore, the suborbital shelf was probably present in basal acanthopterygians.

Character 4 [Lachryopalatine articulation: A, absent; B, present]

Condition A is commonly found in berycoids and percoids (Katayama, 1956, 1959; Fraser, 1968, 1972; Tominaga, 1968; Zehren, 1979; Sasaki, 1989; pers. obs.). Lachryopalatine articulation was probably absent in basal acanthopterygians.

Character 5 [Ventral spines on lachrymal: A, absent; B, present]

All berycoids and percoids examined here had condition A, the same condition having been widely found in other berycoids and percoids (e.g., Katayama, 1956; Zehren, 1979). The lachrymal may have been without spines on the ventral margin in basal acanthopterygians.

Character 6 [Second infraorbital and lateral ethmoid: A, separated; B, attached]

Condition A has been widely found in berycoids and percoids (Katayama, 1956, 1959; Fraser, 1968, 1972; Tominaga, 1968; Zehren, 1979; Sasaki, 1989; pers. obs.). The second infraorbital was probably separated from the lateral ethmoid in basal acanthopterygians.

Character 7 [Anterior spine on lachrymal: A, absent; B, present]

Condition A is generally found in berycoids and percoids (Katayama, 1956, 1959; Fraser, 1968, 1972; Tominaga, 1968; Zehren, 1979; Sasaki, 1989; pers. obs.). The lachrymal probably lacked an anteriorly projecting spine in basal acanthopterygians.

Character 8 [Parasphenoid and pterosphenoid: A, separated; B, attached]

All berycoids and percoids examined here had condition A, which has been widely found in berycoids and percoids (Starks, 1903; Katayama, 1956, 1959; Fraser, 1968, 1972; Tominaga, 1968; Zehren, 1979; Sasaki, 1989). The parasphenoid was probably separated from the pterosphenoid in basal acanthopterygians.

Character 9 [Relatively thin, rounded supraoccipital crest: A, absent; B, present]

A rounded supraoccipital crest is characterized by its lack of the posterior part, which usually exists above the exoccipital. Berycoids and percoids examined here generally had a supraoccipital crest which was not rounded, this condition having been widely found in berycoids and percoids (Gregory, 1933; Katayama, 1959; Fraser, 1968, 1972; Tominaga, 1968; Vari, 1978; Zehren, 1979). Basal acanthopterygians probably did not have such a supraoccipital crest.

Character 10 [Preocular spine: A, absent; B, present]

A preocular spine, located on the lateral ethmoid, was found in the scorpaenids. Since condition A is widely present in berycoids and percoids (Starks, 1903; Gregory, 1933; Katayama, 1959; Zehren, 1979; pers. obs.), basal acanthopterygians probably did not have the preocular spine.

Character 11 [Head spines on postorbital region: A, absent; B, present]

All berycoids and percoids examined here had condition A. Since the condition is generally found in other berycoids and percoids (e.g., Gregory, 1933), such spines were probably absent in basal acanthopterygians.

Character 12 [Parietal and nuchal spines: A, absent; B, present]

The parietal and nuchal spines are located on the posterodorsal face of the cranium of scorpaenids (Eschmeyer, 1969). All berycoids and percoids examined here had condition A. Since this condition is widely present in other berycoids and percoids (e.g., Gregory, 1933), the spines were probably absent in basal acanthopterygians.

Character 13 [Anterodorsal arm of posttemporal: A, not covered by parietal; B, covered]

Condition A is widely found in berycoids and percoids (Katayama, 1959; Fraser, 1972; Vari, 1978; Zehren, 1979; pers. obs.). It is thought that the anterior region of dorsal arm of posttemporal was not covered by the parietal in basal acanthopterygians.

Character 14 [Narrow cartilaginous band on ventral face of frontal: A, absent; B, present]

The condition of the ventral face of the frontal has not been reported in berycoids and

percoids. A narrow cartilaginous band, which is found in certain scorpaeniforms (Kido, 1988), was probably absent in basal acanthopterygians because all berycoids and percoids examined here had condition A.

Character 15 [Ascending process of anguloarticular: A, developed; B, reduced]

Condition A is generally found in berycoids and percoids (Okada and Suzuki, 1956; Tominaga, 1968; Johnson and Fritzsche, 1989; Sasaki, 1989; Smith-Vanitz and Johnson, 1990; pers. obs.). The anguloarticular ascending process may have been developed in basal acanthopterygians.

Character 16 [*Hexagrammos*-type dentition of upper jaw: A, absent; B, present]

Hexagrammos-type dentition can be simply summarized as comprising large, conical teeth among typical, smaller conicals. Although dentitions vary among berycoids and percoids, a *Hexagrammos*-type dentition is not common (e.g., Tominaga, 1968; Zehren, 1979; Sasaki, 1989; pers. obs.). Dentition of this type may have been absent in basal acanthopterygians.

Character 17 [Canines in both jaws: A, absent; B, present]

All berycoids and percoids examined here had condition A. In addition, canines are thought to be found randomly in percoids (e.g., Sasaki, 1989). Therefore, basal acanthopterygians may not have had canines in both jaws.

Character 18 [Notch between ascending and articular processes in premaxillary: A, present; B, absent]

All berycoids and percoids examined here had condition A, the same condition being present in other berycoids and percoids (e.g., Zehren, 1979; Sasaki, 1989). Basal acanthopterygians are thought to have had a notch between the ascending and articular processes of premaxillary.

Character 19 [Ascending process and remaining part of premaxillary: A, not separated; B, separated]

All berycoids and percoids examined here had condition A. Since this condition is widely found in other berycoids and percoids (e.g., Fraser, 1968; Johnson and Rosenblatt, 1988), basal acanthopterygians probably had the ascending process not separated from the remaining part in the premaxillary.

Character 20 [Inner projection on medial face of metapterygoid: A, absent; B, present]

The condition of the medial side of the metapterygoid is unknown in many berycoids and percoids. Since all berycoids and percoids examined here had condition A, basal acanthopterygians may have lacked an inner projection on the metapterygoid.

Character 21 [Operculo-mandibular canal region of preopercle: A, not covered by adductor mandibulae; B, covered]

Condition A is found in berycoids and percoids (Osse, 1969; Elshold-Oldenhave and Osse, 1976; Zehren, 1979; Sasaki, 1989, pers. obs.). The operculo-mandibular canal region of the preopercle was probably not covered by the adductor mandibulae in basal acanthopterygians.

Character 22. [Number of branchiostegal rays: A, seven or more; B, six]

There are generally six to eight branchiostegal rays in berycoids and percoids (McAllister, 1968; Keene and Tighe, 1984; Johnson, 1984; pers. obs.). Since seven branchiostegals are thought to be common among them, basal acanthopterygians probably had seven branchiostegal rays at least.

Character 23 [Beryciform foramen: A, present; B, absent]

Since condition A is generally found in berycoids and percoids (Fraser, 1968; Tominaga, 1968; Zehren, 1979; pers. obs.), basal acanthopterygians probably had a beryciform foramen on the ceratohyal.

Character 24 [Basihyal: A, present; B, absent]

All berycoids and percoids examined here had a basihyal, the bone generally being found in other berycoids and percoids (Zehren, 1979; Johnson, 1984). It was probably present in basal acanthopterygians.

Character 25. [Shape of hypobranchial: A, rod; B, polygonal plate]

Condition A is dominant in berycoids and percoids (Fraser, 1968; Tominaga, 1968; Liem, 1970; Zehren, 1979; Johnson, 1980; Sasaki, 1989; pers. obs.), and was probably characteristic of basal acanthopterygians.

Character 26 [Tooth plate on third epibranchial: A, present; B, absent]

Since condition A is dominant in berycoids and percoids (Tominaga, 1968; Fraser, 1972; Rosen, 1973; Johnson, 1980; pers. obs.), basal acanthopterygians probably had a tooth plate on the third epibranchial.

Character 27 [Second and third basibranchials: A, ossified; B, cartilaginous]

All berycoids and percoids examined here had condition A, the condition being present in many other berycoids and percoids (e.g., Fraser, 1968; Zehren, 1979; Johnson, 1980; Sasaki, 1989). The second and third basibranchials were probably ossified in basal acanthopterygians.

Character 28 [Coracoid arm: A, slim and loosely attached with cleithrum; B, robust and firmly attached to cleithrum]

Since condition A is dominant in berycoids and percoids (Katayama, 1959; Tominaga, 1968; Zehren, 1979; Sasaki, 1989; pers. obs.), the coracoid arm of basal acanthopterygians is thought to have been slim and loosely attached to the cleithrum.

Character 29 [First actinost: A, free from scapula; B, fused to scapula]

All berycoids and percoids examined here had condition A, the condition having been widely found in other berycoids and percoids (e.g., Liem, 1970; Springer and Freihofer, 1978; Sasaki, 1989). The first actinost is thought to have been free from the scapula in basal acanthopterygians.

Character 30 [Position of all actinosts: A, posterior to scapula and coracoid; B, between them]

All berycoids and percoids examined here had condition A, the condition having been widely found in other berycoids and percoids (e.g., Katayama, 1959; Fraser, 1968; Zehren, 1979; Sasaki, 1989). All actinosts were probably located posterior to the scapula and coracoid in basal acanthopterygians.

Character 31 [Accessory spine on head of cleithrum: A, absent; B, present]

Condition A is present in berycoids and percoids (Fraser, 1968; Tominaga, 1968; Zehren, 1979; Sasaki, 1989; pers. obs.). It was probably characteristic of basal acanthopterygians.

Character 32 [Pelvic fin: A, not disc; B, disc]

A pelvic fin, modified into a sucking disc, is thought not to have been present in basal acanthopterygians because such is unknown in berycoids and percoids (e.g., Matsubara, 1955; Nelson, 1984; pers. obs.).

Characters 33 [Number of soft rays in pelvic fin: A, five or more; B, four or less]

There were five or more pelvic fin soft rays in berycoids and percoids examined here, the same condition being dominant in other berycoids and percoids (e.g., Zehren, 1979; Johnson, 1984; Nelson, 1984). There were probably five or more soft rays in the pelvic fin of basal acanthopterygians.

Character 34 [Predorsal: A, present; B, absent]

Since the predorsal is widely found in berycoids and percoids (e.g., Starks, 1903; Katayama, 1959; Zehren, 1979; Johnson, 1984; pers. obs.), such was probably present in basal acanthopterygians.

Character 35 [Distal and proximal pterygiophores: A, attached; B, separated]

The distal pterygiophore may have been attached to the proximal one in basal acanthopterygians because condition A is found in berycoids and percoids (Johnson, 1983, 1986; Sasaki, 1989; pers. obs.).

Character 36 [Arrangement of dorsal pterygiophores relative to interneural spaces: A, not single (double or more in some dorsal spinous part); B, single]

Condition A is dominant in berycoids and percoids (Katayama, 1959; Johnson, 1984; pers. obs.), and was probably characteristic of basal acanthopterygians.

Table 8. Character conditions in Berycoidei and Percoidei. A and B correspond to character conditions used in Appendix. Hyphen indicates no data.

SUBORDER FAMILY	GENUS	Character No.										
		1-5	6-10	11-15	16-20	21-25	26-30	31-35	36-40	41-45	46-50	51-
BERYCOIDEI :												
MONOCENTRIDAE	<i>Monocentrus</i>	AAAAA	AAAAA	AAAAA	AAAAA	AAABA	AAAAA	AAAAA	ABAAA	AAAAA	A-AAA	AAA
DIRETMIDAE	<i>Diretmus</i>	AAAAA	AAAAA	AAAAA	AAAAA	AAABA	BAAAA	AAAAA	ABAAA	B-AB	AAA-	-AA
ANOPLOGASTERIDAE	<i>Anoplogaster</i>	AAAAA	AAAAA	AAAAA	AAAAA	AAABA	BAAAA	AAABA	ABBAA	AAABA	AAA-	-AA
BERYCIDAE	<i>Beryx</i>	AAAAA	AAAAA	AAAAA	AAAAA	AAAAA	AAAAA	AAAAA	AAAAA	AAAAA	AAAAA	AAA
HOLOCENTRIDAE	<i>Ostichthys</i>	AAAAA	AAAAA	AAAAA	AAAAA	AAAAA	AAAAA	AAAA-	AAAAA	AAA-	- - - - -	-AA
TRACHICHTHYIDAE	<i>Hoplostethus</i>	AAAAA	AAAAA	AAAAA	AAAAA	AAABA	AAAAA	AAAAA	AAAAA	AAAAA	AAAAA	AAA
PERCOIDEI :												
PERCICHTHYIDAE												
	<i>Acropoma</i>	AAAAA	AAAAA	AAAAA	AAAAA	AABAA	AAAAA	AAAAA	AAAAA	AAAAA	ABAAA	AAA
	<i>Doederleinia</i>	AAAAA	AAAAA	AAAAA	AAAAA	AAABA	AAAAA	AAAAA	AAAAA	AAAAA	AAAAA	AAA
	<i>Malakichthys</i>	AAAAA	AAAAA	ABAAA	AAAAA	AAAAA	AAAAA	AAAAA	AAAAA	AAAAA	AAAAA	AAA
	<i>Nippon</i>	AAAAA	AAAAA	AAAAA	AAAAA	AAAAA	AAAAA	AAAAA	AAAAA	AAAAA	AABAA	AAA
	<i>Synagrops</i>	AAAAA	AAAAA	AAAAA	AAAAA	AAAAA	AAAAA	AAAAA	AAAAA	AAAAA	AAAAA	AAA
	<i>Stereolepis</i>	AAAAA	AAAAA	AAAAA	AAAAA	AAAAA	AAAAA	AAAAA	AAAAA	AAAAA	AAAAA	AAA
	<i>Lateolabrax</i>	AAAAA	AAAAA	AAAAA	AAAAA	AAAAA	AAAAA	AAAAA	AAAAA	AAAAA	AAAAA	AAA
SERRANIDAE	<i>Epinephelus</i>	AAAAA	AAAAA	AABAA	AAAAA	AAAAA	AAAAA	AAAAA	AAAAA	AAAAA	AABAA	AAA
	<i>Plectranthias</i>	AAAAA	AAAAA	AAAAA	AAAAA	AAAAA	AAAAA	AAAAA	AAAAA	AAAAA	AABAA	AAA
PERCIDAE	<i>Perca</i>	AAAAA	AAAAA	AAAAA	AAAAA	AABAA	AAAAA	AAAAA	BAAAA	AAAAA	AAAAA	AAA
TERAPONIDAE	<i>Terapon</i>	AAAAA	AAAAA	AAAAA	AAAAA	ABAAA	BAAAA	AAAAA	AAAAA	AAAAA	AABAA	AAA
KUHLIIDAE	<i>Kuhlia</i>	AAAAA	AAAAA	AAAAA	AAAAA	ABAAA	BAAAA	AAAAA	AAAAA	AAAAA	AABAA	AAA
MULLIDAE	<i>Upeneus</i>	AAAAA	AAAAA	AAAAA	AAAAA	AAAAA	AAAAA	AAAAA	AAAAA	AAAAA	AAAAA	AAA
PEMPHERIDAE	<i>Pempheris</i>	AAAAA	AAAAA	AAAAA	AAAAA	AAAAA	AAAAA	AAAAA	AAAAA	AAAAA	AABAA	AAA
CIRRHITIDAE	<i>Paracirrhites</i>	AAAAA	AAAAA	AAAAA	ABAAA	ABBAA	AAAAA	AAAAA	AAAAA	AAAAA	AABAA	AAA
	<i>Cirrhichthys</i>	AAAAA	AAAAA	AAAAA	BAAAA	ABBAB	AAAAA	AAAAA	AAAAA	AAAAA	AABAA	AAA
HAEMULIDAE	<i>Haplogenyis</i>	AAAAA	AAAAA	AAAAA	AAAAA	ABBAA	BAAAA	AAAAA	AAAAA	AAAAA	AABAA	AAA

Character 37 [Anal spines with robust pterygiophores : A, present ; B, absent]

Since condition A is dominant in berycoids and percoids (e.g., Zehren, 1979 ; Johnson, 1984 ; pers. obs.), basal acanthopterygians probably had anal spines with robust pterygiophores.

Character 38 [Stay of dorsal and anal fins : A, present ; B, absent]

The stay is present behind the last dorsal and anal pterygiophores in berycoids and percoids (Zehren, 1979 ; Johnson, 1984 ; pers. obs.). Therefore, basal acanthopterygians may have had such in each dorsal and anal fin pterygiophore.

Character 39 [First neural spine : A, not plate-like ; B, plate-like]

Since condition A is widely found in berycoids and percoids (e.g., Hotta, 1961 ; Sasaki, 1989 ; pers. obs.), it was probably also found in basal acanthopterygians.

Character 40 [Direction of first two neural spines : A, dorsally ; B, anteriorly]

Because condition A is dominant in berycoids and percoids (e.g., Hotta, 1961 ; pers. obs.), the first two neural spines may have been directed dorsally in basal acanthopterygians.

Character 41 [Hypurapophysis : A, present ; B, absent]

Dominantly, berycoids and percoids examined here had a hypurapophysis on the parhypural. Basal acanthopterygians may also have had a hypurapophysis because such is generally present in other berycoids and percoids (e.g., Monod, 1968 ; Fujita, 1990).

Character 42 [Base of hypurapophysis : A, narrow ; B, broad]

Condition A is widely found in berycoids and percoids (e.g., Fujita, 1990 ; pers. obs.). The base of hypurapophysis, therefore, may have been narrow in basal acanthopterygians.

Character 43 [A2 section of adductor mandibulae : A, not branched anteriorly ; B, branched]

Condition A is generally present in berycoids and percoids (Liem, 1970 ; Elshold-Oldenhave and Osse, 1976 ; Johnson, 1980 ; Sasaki, 1989 ; pers. obs.). Therefore, basal acanthopterygians may have had the adductor mandibulae A2 section, being unbranched.

Character 44 [A1 section of adductor mandibulae : A, not separated into inner and outer subsections ; B, separated]

Since condition A is dominant in berycoids and percoids (Liem, 1970 ; Elshold-Oldenhave and Osse, 1976 ; Johnson, 1980 ; Sasaki, 1989 ; pers. obs.), the A1 section may not have been separated into inner and outer subsections in basal acanthopterygians.

Character 45 [Third levator externus : A, present ; B, absent]

Condition A is found in berycoids and percoids (Liem, 1970 ; Lauder, 1983 ; Sasaki, 1989 ; Wainwright, 1989 ; Vandewalle et al., 1992 ; pers. obs.). According to Winterbottom (1974), the third levator externus is absent among specialized acanthopterygians. Therefore, the muscle was probably present in basal acanthopterygians.

Character 46 [Arrector ventralis in pectoral fin : A, developed ; B, reduced]

All berycoids and percoids examined here had condition A, which has also been found in the Nandidae (Liem, 1970) and Sciaenidae (Sasaki, 1989). The arrector ventralis may have been developed in basal acanthopterygians.

Character 47 [Extensor proprius in pelvic fin : A, present ; B, absent]

All berycoids and percoids examined here had condition A. Although the distribution of this muscle is not well known (Winterbottom, 1974), it has been found in other percoids such as the Nandidae (Liem, 1970) and Sciaenidae (Sasaki, 1989). The extensor proprius may have been present in basal acanthopterygians.

Character 48 [Adductor dorsalis in caudal fin : A, absent ; B, present]

All berycoids and about half of percoids examined here had condition A, the muscle only being found in certain percoids (Nursall, 1963 ; Winterbottom, 1974). The adductor dorsalis may have been absent in basal acanthopterygians.

Character 49 [RLA pattern 12 : A, absent ; B, present]

The RLA patterns (*sensu* Freihof, 1963) varied in berycoids and percoids examined here. Because pattern 12 is absent in berycoids and percoids (Freihof, 1963, 1978 ; Springer and

Freihofer, 1976; Johnson and Fritzsche, 1989; pers. obs.), it was probably also absent in basal acanthopterygians.

Character 50 [RLA pattern 11 : A, absent ; B, present]

Since this pattern is absent in berycoids and percoids (Freihofer, 1963, 1978; Johnson and Fritzsche, 1989; pers. obs.), it was probably also absent in basal acanthopterygians.

Character 51 [RLA pattern 7 (?) : A, absent ; B, present]

All berycoids and percoids examined here lacked pattern 7(?), which is slightly similar to that of gadids (Freihofer, 1963). In addition, the pattern has not been reported in other berycoids and percoids (e.g., Freihofer, 1963, 1978). RLA pattern 7 (?) was probably absent in basal acanthopterygians.

Character 52 [*Pleurogrammus*-type lateral lines : A, absent ; B, present]

The *Pleurogrammus*-type multiplication of lateral line can be simply summarized as five lines in which the second one is located on the mediolateral region of the body (Ruttenberg, 1962). Since such multiplication is generally absent in berycoids and percoids (Matsubara, 1955; Katayama, 1960; Lindberg, 1971; Woods and Sonoda, 1973; Nelson, 1984; pers. obs.), basal acanthopterygians probably lacked *Pleurogrammus*-type lateral lines.

Character 53 [First four dorsal spines : A, not elongated ; B, elongated]

All berycoids and percoids examined here had condition A, the condition being dominant in berycoids and percoids (e.g., Lindberg, 1971; Woods and Sonoda, 1973; Nelson, 1984). The first four dorsal spines were probably not elongated in basal acanthopterygians.