



# HOKKAIDO UNIVERSITY

Title	Effect of Wood Matrix Moisture Content on the Degradation Rate and Microbial Composition in the Household Garbage Automatic Decomposer-Extinguisher (GADE) Machine
Author(s)	HORISAWA, Sakae; MORISHITA, Takayoshi; SAKUMA, Yoh et al.
Citation	Eurasian Journal of Forest Research, 6(2), 137-142
Issue Date	2003-09
Doc URL	<a href="https://hdl.handle.net/2115/22169">https://hdl.handle.net/2115/22169</a>
Type	departmental bulletin paper
File Information	6(2)_P137-142.pdf



## Effect of Wood Matrix Moisture Content on the Degradation Rate and Microbial Composition in the Household Garbage Automatic Decomposer-Extinguisher (GADE) Machine

HORISAWA Sakae<sup>1,2\*</sup>, MORISHITA Takayoshi<sup>3</sup>, SAKUMA Yoh<sup>4</sup>, DOI Shuichi<sup>1</sup>  
and TERAZAWA Minoru<sup>3</sup>

<sup>1</sup> Institute of Wood Technology, Akita Prefectural University, Noshiro, Akita 016-0876, Japan

<sup>2</sup> Present address: Department of Environmental Systems Engineering, Faculty of Engineering, Kochi University of Technology, Kami-gun, Kochi 782-8502

<sup>3</sup> Graduate School of Agriculture, Hokkaido University, Sapporo 060-8589, Japan

<sup>4</sup> Biological Resources Division, Japan International Research Center for Agricultural Sciences, Tsukuba 305-8686, Japan

### Abstract

To determine the optimum wood matrix moisture content for the GADE machine, model waste degradation experiments were conducted. The controlled wood matrix moisture content was adjusted to 30%, 40%, 50%, and 60%, respectively. Rate of weight loss, temperature of the matrix, and ATP content in each matrix were evaluated for 15 days. The weight loss rates were similar at moisture content levels of 40%-60%, even though high temperatures and ATP levels were observed at moisture content levels of 40% and 50%. The matrix microbial communities were analyzed by PCR-denaturing gradient gel electrophoresis (DGGE) using a nucleotide sequence of bacterial 16S rDNA. The microbial community structures were stable from the 5th to the 15th day in each moisture content container and were also similar among the moisture content levels except for 30% level. The degradation rates were appeared to differ under different environmental conditions (moisture content and temperature) even when the microbial communities were similar. Our results indicate that the optimum moisture content is 40%-50% in the household GADE machine.

*Key words:* GADE machine, wood matrix, moisture content, biodegradation, DGGE

### Introduction

The generation of waste continues to increase while the waste disposal of landfills and incinerators becomes increasingly limited. Alternative processes that lessen the burden on the environment and are cost and energy efficient and are needed material-recycling systems are expected to be helpful. Therefore, a garbage automatic decomposer-extinguisher (GADE) system was developed for recycling organic waste by using sawdust as a wood matrix to support microorganisms (Terazawa *et al.* 1992, Terazawa *et al.* 1999, Kawamoto and Nochi 1998, Matsuzaki 1997, Maeda *et al.* 2000). Microorganisms in the GADE machine aerobically degrade food wastes. However, unacceptably low degradation rates or odor production has often been problematic because the optimum operation conditions for the GADE machine have not been established. In addition, suspicious additive materials and inoculants at waste degradation have been flooded. However, we predicted that environmental conditions, rather than additives or inoculants are the criteria important for efficient degradation. Thus, we determined the optimum environmental temperature and wood matrix moisture content conditions using small-scale equipment to be 20°C-40°C and 30%-60% wet weight, respectively (Horisawa *et al.* 2000, Horisawa *et al.*

2001a). However, optimum conditions should be determined for each GADE scale, for example household or commercial size.

Under the different environmental conditions, the dynamics of the microbial species were also investigated in order to examine the relationship between degradation rate and microbial community. Using aseptic wood matrix and sterilized waste, microbial communities were established from microorganisms in the environmental air specific to the particular environmental conditions (Horisawa *et al.* 2000, Horisawa *et al.* 2001a, Horisawa *et al.* 2001b). Time and labor intensive cultivation methods were employed in these studies. Recently, molecular methods have been used for analysis of microbial community structure. Molecular methods are fast and easy, and detect microorganisms that cannot be cultured. Particularly, denaturant gradient gel electrophoresis (DGGE) analysis is useful for analyzing microbial community structures (Muyzer *et al.* 1993).

In this study, we determined the optimum moisture content for the household-GADE machine and analyzed the microbial community structures in the moisture contents using DGGE analysis.

## Materials and methods

### Biodegradation experiment using the GADE machine

The household GADE machine (Mitsui home, Tokyo) with a 50-liter volume and degradation capacity of 1 kg (wet weight) per day (Fig. 1). A mixture of sawdust from white fir (*Abies sachalinensis* (Fr. Schm) Masters) and spruce (*Picea jezoensis* (Sieb. et Zucc) Carriée) was sieved to diameters of less than 1.7 mm. Forty-liter sawdust samples were adjusted to the moisture contents (MC) of 30%, 40%, 50%, and 60% on a wet weight basis, respectively, and put in each machine. The MCs of wood matrix samples were kept at a constant level by adding water. Commercial rabbit feed was used as the experimental waste because the protein, fat, fiber, and ash conditions are similar to the concentration of those components in actual food waste (Horisawa *et al.* 2000). Two hundred-g experimental waste samples were grinded by a mill and applied. The MCs of the waste samples were also adjusted to 30%, 40%, 50%, and 60% on a wet weight basis, respectively. The wood matrices were stirred automatically by the machine blades for 6 min every 30 min and also stirred for 3 min after was opened and shut. The wood matrices were sampled every 24 h and the sample MCs were measured with an infrared MC meter. Weight loss of the experimental waste samples was determined by the method reported previously (Horisawa *et al.* 2000). The temperature in the containers was measured continuously by a thermocouple. Each experiment was conducted at room temperature (about 20°C) for 15 days.

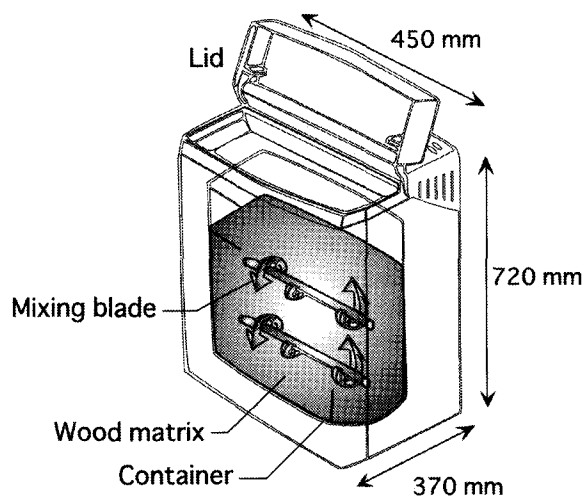

Fig. 1. The household GADE machine with a capacity of 1.0 kg per day using 4 kg of sawdust.

### Measurement of ATP content

One-g of sample was added to 10 ml of TCA extraction buffer (0.25 M  $K_2HPO_4$ , 0.5M trichloroacetic acid) and homogenized. The homogenized buffer samples were centrifuged at 2000 x g for 20 min. After

centrifugation, the supernatants collected were diluted 100-fold. The ATP content of the samples was analyzed by an ATP analyzer AF-100 (TOA, Tokyo, JPN). ATP concentrations were converted to the dry weight basis of the wood matrix samples.

### DNA extraction

Wood matrix samples were collected from the GADE machine at the day 5, 7, 10, 12, and 15. Microorganism DNA was extracted from the collected matrices by the benzyl chloride method (Zhu *et al.* 1993). Two-g (fresh weight) wood matrix samples were collected in tubes. To each tube, 20 ml TE buffer (10 mM Tris-HCl, 1 mM EDTA, pH 8.0), 12 ml benzyl chloride, 2 ml mercaptoethanol, and 4 ml 10% SDS were added. The tubes were incubated at 50°C for 30 min with reversing at 5 min intervals to keep the two phases thoroughly mixed. The tubes were centrifuged at 3000 x g and 4°C for 30 min and supernatant was collected. DNA was extracted from the supernatants with phenol and chloroform-isoamylalcohol (25:24:1). DNA was precipitated with isopropanol and sodium acetate, gathered by centrifugation, and the DNA pellets were rinsed with 70% ethanol and dried. DNA was dissolved in 5 ml TE containing RNase. DNA was first purified on a column (Qiagen Inc., CA, USA) and then further purified by an extraction with 10% PVP and phenol-chloroform-isoamylalcohol to remove phenols (Young *et al.* 1993).

### DNA amplification and DGGE analysis

The partial ribosomal DNA was amplified with the bacterial primer 341F with a GC clamp (5'-CgC CCg CCg CgC CCC gCg CCC gTC CCg CCg CCC CCg CCC-CCT ACg ggA ggC AgC Ag-3') and the universal primer 907R (5'-CCg TCA ATT CMT TTg AgT TT-3') (Casamayor *et al.* 2000). The PCR mixture was prepared from the Expand™ High Fidelity PCR System (Roche-Diagnostics, Basel, Switzerland) according to the manufacturer's instructions, and contained 10 ng of template DNA, each primer at a concentration of 0.5 pM, each dNTP at a concentration of 200 nM, 1.5U/100µl of DNA polymerase, and Expand™ reaction buffer with 1.5 mM  $MgCl_2$ . PCR was performed with a GeneAmp 2400 thermal cycler (Applied Biosystems, CA, US). A touch-down PCR program was used to minimize nonspecific amplification (Don *et al.* 1991) with the following parameters: an initial denaturation of 5 min at 94°C, 20 cycles of 1 min at 94°C, 1 min at 65°C (the temperature was decreased by 0.5°C every cycle until the touchdown temperature of 56°C was reached), 1 min at 72°C, 15 additional cycles with annealing temperature of 55°C and a final extension of 7 min at 72°C. All PCR products were stored at 4°C until used. Aliquots of PCR products were evaluated after separation on a 0.8% agarose gel.

DGGE was performed with a DGGE system (Nihon Eido, Tokyo, JPN). PCR samples were applied directly onto 6% (wt/vol) polyacrylamide gels in 1 x TAE (40 mM Tris-acetate [pH 8.0] and 1.0 mM disodium EDTA). The denaturing gradients contained 25 to 50%

denaturant (100% denaturant corresponded to 7 M urea and 40% [vol/vol] formamide). Electrophoresis was performed for 5 h at 180 V. The temperature was set at 60°C. After electrophoresis, the gels were stained with ethidium bromide.

### Sequencing

The DGGE bands were excised from the gels, re-amplified by PCR, and electrophoresed again in DGGE gels to confirm mobility of the bands. The new PCR products were cloned. A Bigdye terminator cycle sequencing Ready Reaction kit (Applied Biosystems, CA, US) was used to sequence the reamplified fragments. The sequenced reactions were performed with an Applied Biosystems Prism 3100 genetic analyzer. A BLAST search identified the first sequences retrieved. All nucleotide sequences were aligned using the CLUSTAL X program (Thompson *et al.* 1997). A neighbour-joining (NJ) tree was drawn from the output of CLUSTAL X with njplot.

### Results

#### Rate of weight loss, temperature of matrix, and ATP content

Dry weights were plotted sequentially and then the rates of weight loss (R-w) were determined from the slopes of the changes in weight. The average R-ws

were 7.33, 10.18, 11.38, and 10.10 (g/day) at the MCs of 30%, 40%, 50%, and 60%, respectively (Fig. 2). The R-ws were nearly the same in all containers except for the container with 30% MC. At the MC of 30%, R-w decreased significantly at the  $P=0.05$  level as determined by ANOVA and LSD tests. The temperatures of matrices in the containers (TOM) changed with time during the experiment and were higher during the initial stage and lower during the later stage except for the container with 30% MC (Fig. 3). At 30% MC, the TOM remained at an almost constant level of 24-26°C. At 40% and 50% MC, the TOM reached around 30°C during the initial stage and then decreased after the middle stage. At 60% MC, the TOM was highest level on the second day when the TOM measurements started and declined gradually. ATP contents in the matrices are shown in Fig. 4. ATP content is thought to indicate the level of biological activity of the microbial community. The ATP content increased faster in the matrices with higher MC levels during the initial stage. At the MC of 30%, the ATP content increased slowly and peaked during the 11th day. At the MCs of 40% and 50%, the ATP content peaked during the 5th day and then declined. The ATP content was highest in the container with the MC level of 60%, but the R-w did not reached at high level.

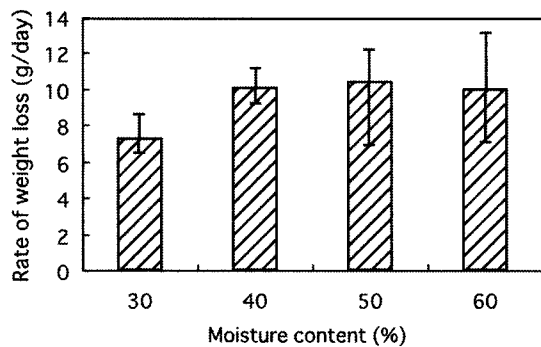

Fig. 2. Rate of weight loss of model waste. Bars show maximum and minimum values in the three timed trials.

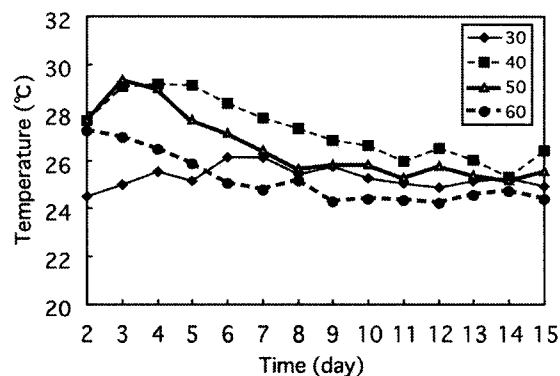

Fig. 3. Temperatures of GADE machine containers. Plots show average level per day.

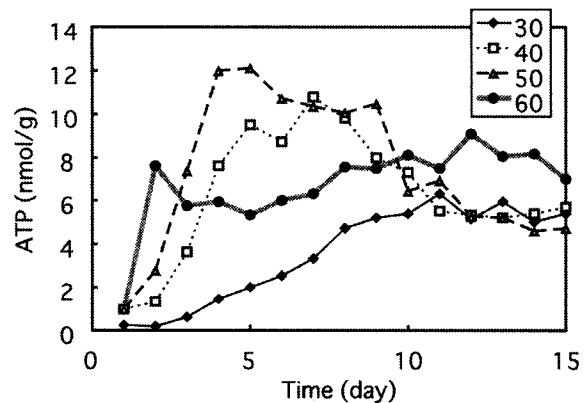

Fig. 4. ATP content on a dry weight basis in the wood matrices.

#### Profiling structure of microbial community by DGGE analysis

The DNA fragments amplified from various kinds of microbes were separated by DGGE according to the nucleotide sequences. The microbial community was visualized as bands, with each band presenting a single species. Because the specific bacterial primers were employed in this study, we were able to characterize the bacterial communities. Fig. 5 shows the microbial community structures sequentially on the 5th, 7th, 10th, 12th, and 15th day at each MC level. The band patterns in the lanes indicate the community structure during that time. Band patterns were similar at each MC, indicating that stable microbial communities were formed from the 5th to the 15th day. The containers with MCs of 40%, 50%, and 60% had very similar

microbial communities, while the container with 30% MC had a pattern different from the others. These microbial community results agree with the R-w data.

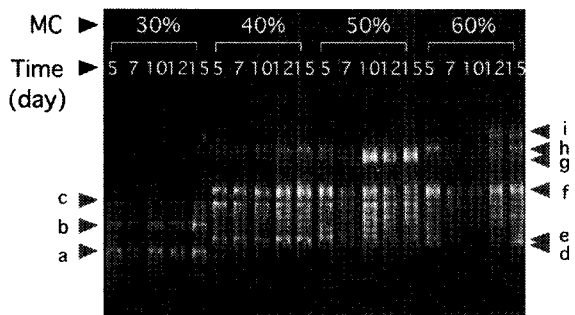

Fig. 5. DGGE analysis of PCR-amplified 16S rDNA fragments obtained with primers 341GC-907 and bacterial genomic DNA from the wood matrices in the GADE machines. Letters a, b, c, d, e, f, g, h, and i are names of major bands.

### Phylogenetic affiliations of predominant community microbes

The main bands in the DGGE gel (Fig. 5) were excised, re-amplified, and sequenced. Results of the BLAST search are shown in the NJ tree in Fig. 6 and the identities of each band are shown in Table 1. Band c, the common band in all samples, was identified as *Sphingomonas sp.*

### Discussion

The R-ws in the household GADE machine were similar in containers MCs of 40%-60% and lower in the container with the 30% MC level. The optimum MC in the small-scale degradation machine previously reported was wider than this range of 30%-60% and was significantly lower at the MC of 20% (Horisawa *et al.* 2000). The R-w at the MC of 20% probably resulted from conditions that were too dry for most bacteria. In this study, the R-w was clearly reduced at the MC of 30%, as was the ATP concentration. This reduced R-w was caused by environmental conditions, including temperature in the container of the GADE machine. The temperature difference between the outer and center of the container was minimal in the small-scale machine but not in the household machine. The matrix

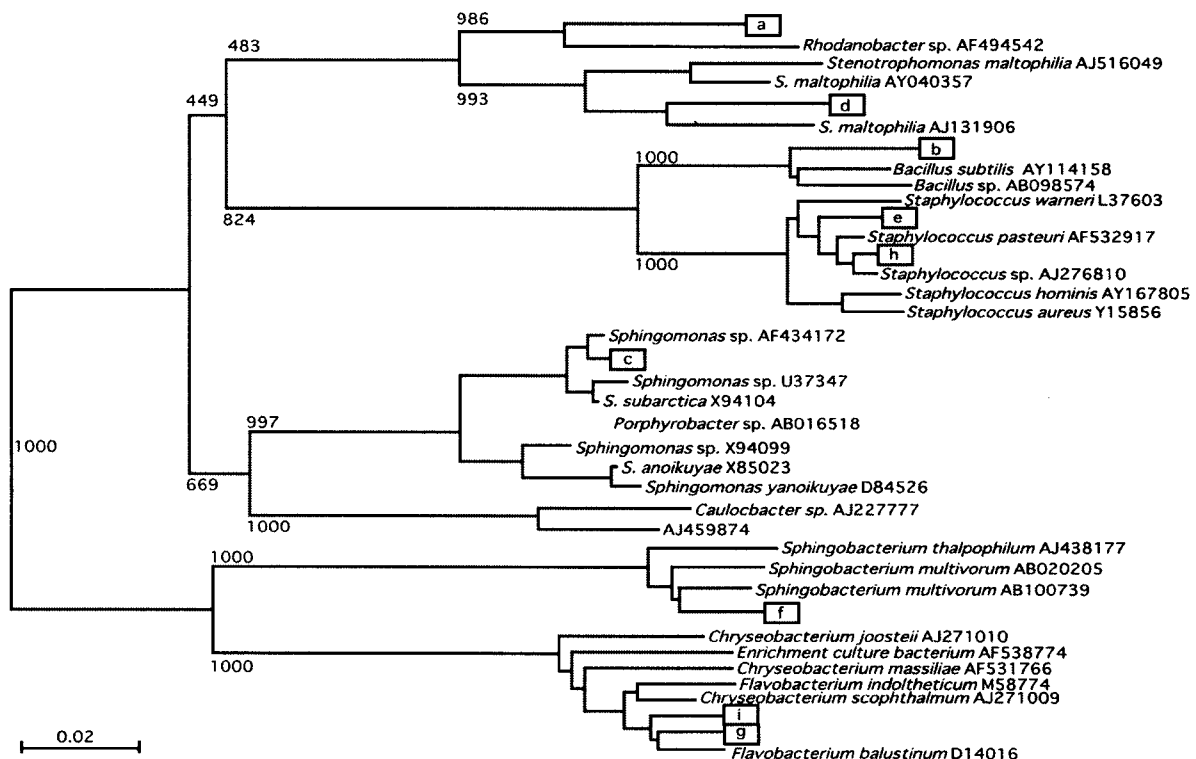

Fig. 6. A neighbor-joining (NJ) tree obtained from inferred sequences of isolated fragments and those related species. The sequences of 16S rDNA were aligned by using the multisequence alignment program CLUSTAL X. Letters in squares (a-i) show the isolated fragments. Code numbers following the species name are accession numbers in the DDBJ database.

Table 1. The closest relatives of the 16S rDNA sequences.

Excised band	Related sequence	Similarity (%)
a	<i>Rhodanobacter lindanoclasticus</i>	97
b	<i>Bacillus subtilis</i>	99
c	<i>Sphingomonas</i> sp.	99
d	<i>Stenotrophomonas maltophilia</i>	97
e	<i>Staphylococcus warneri</i>	99
f	<i>Sphingobacterium multivorum</i>	99
g	<i>Porphyrobacter tepidarius</i>	97
h	<i>Staphylococcus warneri</i>	99
i	<i>Chryseobacterium scophthalmum</i>	97

temperature differences probably caused the different R-ws observed in the container with 30% of MC and the containers with 40%-50% MC. Therefore, we propose that the optimum MC for the household GADE machine is 40%-50%.

The microbial community structures were very similar from the 5th to the 15th day at each MC. The microbial community appeared to form during the early stages and remained stable even as the TOM and ATP concentration changed. The same microbial community structures were presented in container with MC levels of 40%-60%. The R-w data was consistent with this while the TOM and ATP content was not, suggesting that degradation performance might vary due to environmental conditions even when microbial communities are similar. Regulation of environmental conditions appears to be the most important variable that should be controlled in order to obtain high performance of the GADE machine.

#### Acknowledgements

Parts of this work were supported by a research grant from TOSTEM Foundation for Construction Materials Industry Promotion. We thank Life Science Research Support Center, Akita Prefectural University for the DNA sequence analysis. We express our appreciation to Ms. Yukiko Hatakeyama, Ms. Yumiko Miura, and Ms. Ayako Sato of the Institute of Wood Technology, Akita Prefectural University for their technical assistance.

#### References

- Casamayor, E.O., Schäfer, H., Bañeras, L., Pedrós-Alió, C., and Muyzer, G. (2000) Identification of and Spatio-Temporal Differences between Microbial Assemblages from Two Neighboring Sulfurous Lakes: Comparison by Microscopy and Denaturing Gradient Gel Electrophoresis. *Appl. Environ. Microbiol.* 66(2): 499-508.
- Don, R.H., Cox, P.T., Wainwright, B.J., Baker, K., and Mattic, J.S. (1991) 'Touch down' PCR to circumvent spurious priming during gene amplification. *Nucleic Acids Res.* 19: 4008.
- Horisawa, S., Sakuma, Y., Tamai, Y., Doi, S., and Terazawa, M. (2001a) Effect of Environmental Temperature on a Small Scale Bio-degradation System for Organic Solid Waste. *J. Wood Sci.* 47: 154-158.
- Horisawa, S., Sakuma, Y., Tamai, Y., Doi, S., and Terazawa, M. (2001b) Succession of the Community of Dominant Growth-Bacteria in an Aerobic Biodegradation Machine for Garbage Which Uses a Wood matrix. *Eurasian J. For. Res.* 3: 11-22.
- Horisawa, S., Sunagawa, M., Tamai, Y., Matsuoka, Y., Miura, T., and Terazawa M. (1999) Biodegradation of Non-lignocellulosic Substances II: The Physical Properties and Deterioration of Sawdust as an Artificial Soil, *Journal of Wood Science*, 45(6), 492-497.
- Horisawa, S., Tamai, Y., Sakuma, Y., Doi, S. and Terazawa M. (2000) Effect of Moisture Content of Matrix on a Small Scale Bio-degradation System for Organic Solid Waste. *J. Wood Sci.* 46: 317-321.
- Kawamoto, K. and Nochi, K. (1998) The characterization and estimation of performance of the small scale bio-degradation machine. *Proceedings of the 8th Annual Conference of the Japan Society of Waste Management Experts*, pp.283-286 (in Japanese).
- Maeda, T., Matsuda J., Nakashima, H., Yoshida, K., and Suzuki J. (2000) Composting of food refuse from a student restaurant in Hokkaido University. *J. Material Cycles and Waste Management* 2: 143-149.
- Matsuzaki T. (1997) Comparison of composting system for food waste. Date, N., Omori, H, Matsui, S., Matsuzaki, T., Matsushita, Y., Mori, T., Watanabe, Y. (eds.) *Encyclopedia of recycle of organic waste*. Nobunkyo, Tokyo, pp. 308-315 (in Japanese).
- Muyser, G., De Waal, E. C., and Uitterlinden A. G. (1993) Profiling of complex microbial populations by denaturing gradient gel electrophoresis analysis of polymerase chain reaction-amplified genes coding for 16S rRNA. *Appl. Environ. Microbiol.* 59: 695-700.
- Terazawa, M., Horisawa, S., Tamai, Y. and Yamashita, K. (1999) Biodegradation of Non-lignocellulosic Substances I: A System for the Complete Decomposition of Garbage using Sawdust and Aerobic Soil Bacteria. *J Wood Sci.* 45: 354-358.
- Terazawa, M., Tamai, Y., Sunagawa, M., Horisawa, S.,

- and Miura, T. (1992) A novel system for garbage complete decomposition using sawdust and aerobic soil bacteria. Proceedings of the 7th European Conference on Biomass, Energy and Environment, Agriculture and Industry, Florence, Italy, p.589-594.
- Thompson, J.D., Gibson, T.J., Plewniak, F., Jeanmougin, F., and Higgins, D.G. (1997) CLUSTAL X Windows interface: flexible analysis tools. *Nucleic Acids Res.* 25: 4876-4882.
- Young, C.C., Burghoff, R.L., Keim, L.G., Minak-Bernero, V., Lute, J.R., and Hinton, S.M. (1993) Polyvinylpyrrolidone-Agarose gel Electrophoresis Purification of Polymerase Chain Reaction-Amplifiable DNA from Soil Appl. *Environ. Microbiol.* 59(6): 1972-1974.
- Zhu, H., Qu, F., and Zhu, L. H. (1993) Isolation of genomic DNAs from plants, fungi and bacteria using benzyl chloride. *Nucleic Acids Research* 21(22): 5479-5580.