



HOKKAIDO UNIVERSITY

Title	STUDIES ON THE MUSCLE MEAT OF PARALITHODES CAMTSCHATICA (TILESIIUS)-(II)
Author(s)	Tanikawa, Eiichi; Nagasawa, Yoshio; Akiba, Minoru
Citation	北海道大學水産學部研究彙報, 10(3), 257-276
Issue Date	1959-11
Doc URL	https://hdl.handle.net/2115/23081
Type	departmental bulletin paper
File Information	10(3)_P257-276.pdf



STUDIES ON THE MUSCLE MEAT OF *PARALITHODES* *CAMTSCHATICA* (TILESIIUS)-(II)

Eiichi TANIKAWA, Yoshio NAGASAWA and Minoru AKIBA

Faculty of Fisheries, Hokkaido University

X. SHRINKAGE OF CRAB MEAT BY HEATING

Since the invention of so called "low temperature boiling method"^{3a,3b,3c} has been perfected in order to make canned boneless crab meat or to prevent the bluing of canned crab meat, the authors have been obliged to ascertain the physical or chemical properties of crab meat.

Studies in this series have previously been published to clarify the solubility, swelling and heat coagulation of crab meat (*Paralithodes camtschatica*); here is presented a study on the heat-shrinkage of the meat during the boiling process ("high temperature boiling method" or "low temperature boiling method").

1. Difference of heat-shrinkage by the parts of crab meat

(1) Experimental material

Leg meat of fresh raw crab (of which V. B. -N was 7.23 mg%) was cut at the joints. Then the crust was carefully removed with a knife without injuring the skin of the meat. The meat was divided into four parts: "first leg meat" (round meat), "joint meat" (so called scallion-type meat), "second leg meat" (so called pepper-type meat) and "claw meat" (not so called "scissor" meat). (Ref. Fig. 24).

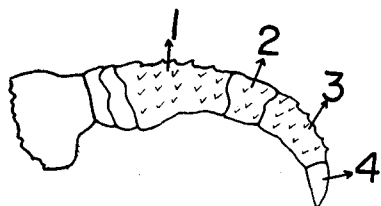

Fig. 24. Names of parts of crab leg meat

1. First leg meat
2. Joint meat
3. Second leg meat
4. Claw meat

(2) Experimental method

The estimation of shrinkage of the crab meat was undertaken by means of the instrument shown in Fig. 25.²⁴ Each end of the sample meat (1) was tied vertically with cotton string, of which the lower string was fixed to the fixed bar (2), and the other end was hung from an end (a) of the lever (3). The sample meat was soaked in a thermostat (a water tank with thermoregulator).

An iron chain having a known definite weight was suspended from the other end (b) of the lever (3) in order to keep the lever in horizontal position. The distance of the bindings of the sample meat (the upper and lower parts) with cotton string was about 5 cm. The water in a tank was heated by electric heater with agitating. The temperature of the water was regulated by a slide regulator in order to increase the temperature at about 2.5°C per minute.

By heating the crab meat begins to show shrinkage. The state of shrinkage of the

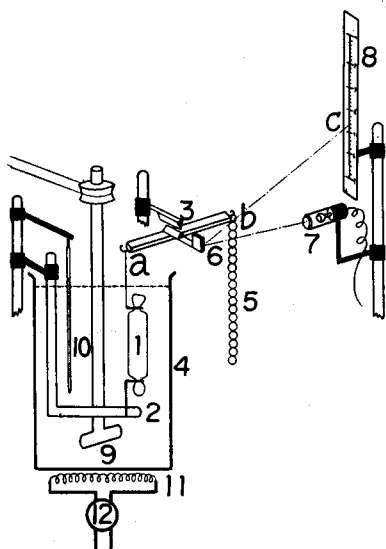

Fig. 25. Apparatus for estimating heat-shrinkage of the crab meat

1. Sample meat
2. Fixed bar
3. Lever
4. Water tank
5. Iron chain
6. Mirror
7. Lamp
8. Lamp-scale
9. Agitator
10. Thermometer
11. Heater

meat is transmitted and presented as follows: the shrinkage of the meat \rightarrow lever \rightarrow mirror (6) \rightarrow lamp-scale (8). The distance of the movement of the light beam on the lamp-scale is measured by the scale nicked on the lamp-scale. The degree of the shrinkage is calculated by the following equation:

$$\varepsilon = \frac{l_n - l_o}{l_o} \times 100 = \frac{\Delta l}{l_o} \times 100 \dots\dots(1)$$

Here, ε is the ratio of the shrinkage of the meat, l_o is the initial length of the meat, l_n is the length after the heating, Δl is variation of the length during the heating.

In this case, when the worker knows distance of the movement of the light beam representing a definite degree of shrinkage of the sample meat, the ratio of shrinkage of the sample meat is directly obtained by observation of the distance of the movement of the light beam on the lamp-scale.

In this experiment, distilled water was used for the heating. The results as to sea water or fresh water for the heating will be reported below in a later part of this paper.

(3) Experimental results and discussion

The variations of ratios of shrinkage of the first leg meat, the joint meat, second leg meat and claw meat by the heating temperatures are shown in Fig. 26.

As seen in Fig. 26, there are two parts in the curves showing the variations of the ratios of shrinkage of the meat: a part in which the ratio of shrinkage rapidly increases, and the other part in which the ratio increases slowly until almost horizontal. In other words, with the rising of the heating temperature, the meat begins shrinkage rapidly at a definite temperature; with further rising, rapid shrinkage turns to a slow shrinkage, followed by rapid shrinkage again and finally to slow shrinkage.

Thus the course of shrinkage takes two or three steps. Here the authors have called the step which occurred at first in the curve, i. e., from the beginning of rapid shrinkage to the end of the slow shrinkage, "the first step of shrinkage", in which first step both the stages of rapid shrinkage and of slow shrinkage are included.

Once more let attention be given to Fig. 26. There will be observed that there are differences of the conditions of shrinkage caused by heating in the different parts of crab meat. The ratio of shrinkage of the first leg meat during the heating was the most

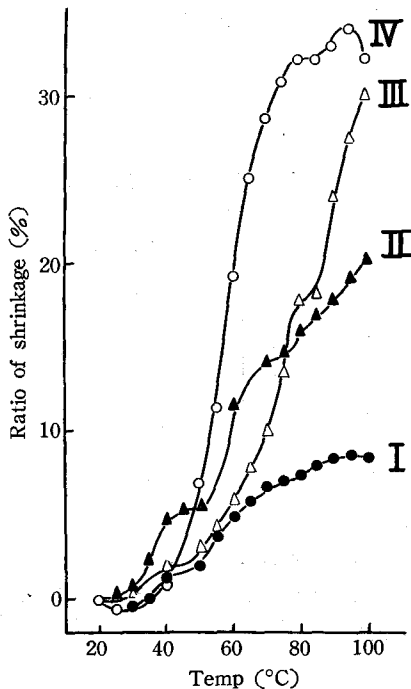

Fig. 26. Variation of the ratios of shrinkage of the sorts of crab meat caused by heating temperatures

- I. First leg meat
- ▲— II. Joint meat
- △— III. Second leg meat
- IV. Claw meat

be three steps of shrinkage by heating in the case of the first leg meat and the joint meat.

As to the second leg meat (curve III), the first step of shrinkage began to occur at 30°C, and reached the slow shrinkage stage at 35° ~ 45°C; rapid shrinkage began to occur at 45° ~ 80°C again, and then the slow shrinkage appeared at 80° ~ 85°C. Thus the second step of shrinkage was over. At 85° ~ 100°C the rapid shrinkage occurred. Thus shrinkage of the second leg meat had only 2 steps with rising of the temperature.

As to the difference of shrinkage of the second leg meat from the first leg meat or the joint meat, the parts of slow shrinkage, which show clear boundaries of each step of shrinkage process, are shorter in the former than in the latter.

As shown by curve IV (the claw meat), the rapid shrinkage began at about 35° C, continued straight to 80°C, and reached to the stage of the slow shrinkage at 80° ~ 85°C. At 85° ~ 95°C the shrinkage began again, and above 95°C, the meat shrinkage did not

small (ϵ was only 8.47 %), with the joint meat, the second leg meat and the claw meat in order following.

The ratio of shrinkage of claw meat was the largest (ϵ was 34.7 %). Inspecting the difference of the variations of the ratios of shrinkage of the meats during heating in Fig. 26, one will notice that the curve of the first leg meat (curve I) resembled that of joint meat (curve II).

Those meats began shrinkage at 30° ~ 35°C and reached the part of slow shrinkage at 40° ~ 50° and thus the first step was over. When the heating temperature became higher than above 50°C, the second stage of rapid shrinkage began to occur continuing until 70°C temperature was reached. Another stage of slow shrinkage occurred between from 70° to 80°C. Thus "the second step of shrinkage process" was over. When the heating temperature became higher than 80°C, shrinkage began to occur again, and slow shrinkage process continued from 95° to 100°C. Thus "the third step" was over. When the heating temperature became higher than 100°C, the meat, which has shown shrinkage to this temperature, began reversely to lengthen. Thus there are observed to

occur but contrawise the length increased. Thus the curve of shrinkage of the claw meat caused by heating has only one step.

According to the results above described, the ranges of the temperature of slow shrinkage of various parts of the leg meat are shown in Table 4.

Table 4. Ranges of the temperature of slow shrinkage of parts of the leg meat of crab

Part Step	1st leg meat	Joint meat	2nd leg meat	Claw meat
1	40° ~ 50°C	40° ~ 50°C	35° ~ 45°C	?
2	70° ~ 80°C	70° ~ 80°C	80° ~ 85°C	80° ~ 85°C
3	95° ~ 100°C	95° ~ 100°C		

As seen in Table 4, the curves of the first leg meat and the joint meat have three steps with the rising of the heating temperature; on the other hand the curve of the second leg meat has only two steps.

In the process of shrinkage of the meat as a respect of heating, the fact that there are two occurrence of slow shrinkage at 40° ~ 50°C and again at 70° ~ 80°C, suggests the presence of two main groups of protein in the crab meat as observed in the curves of the dehydration of the meat by heating or of the heat coagulation reported previously in section, VIII³³⁾ of these studies.

The first slow shrinkage of the meat at 40° ~ 50°C is suggested to have happened as a result of the coagulation of myosin (actomyosin), and the second slow shrinkage at 70° ~ 80°C by the presence of the non-myosins (myogen, haemocyanin, etc.).

However, in curve IV (the claw meat), there is no slow shrinkage process at 40° ~ 50°C, a rapid shrinkage is seen from 35°C, the ratio of shrinkage shows uniform increase, and a slow shrinkage was seen at 80° ~ 85°C. Between 85° ~ 95°C, rapid shrinkage was observed, but above 95°C, on the contrary the meat lengthened.

The results as above obtained in the claw meat may be explained by the fact that in the claw meat there is small amount of myosins, therefore the slow shrinkage process at 40° ~ 50°C owing to the heat coagulation of myosins was not remarkable. Besides the above explanation, the difference of the histological construction of the claw meat from the other parts of the leg meat is suggested. That is to say, the claw meat has smaller amount of muscular tissue, and larger amount of epidermis tissue than other parts of the leg meat. As observed in the previous section, II,³³⁾ the epidermis tissue of *Paralithodes camtschatica* has the construction of connective tissue. According to Takahashi,³⁴⁾ collagen fiber in the connective tissue of fish skin of cod, shark and salmon begins shrinkage when heated at 33° to 40°C. The fact that the claw and second leg meat begins to shrink rapidly at comparatively lower temperature, at about 35°C, than other parts of the leg meat seems to be owing mainly to shrinkage of collagen fiber in the claw and second

leg meat.

Such being the case, the difference of the curve of shrinkage of the meats caused by heating between first leg meat or joint meat and second leg meat or claw meat seems to be owing to the difference of the histological construction. In other words, in first leg meat or joint meat the part of muscular tissue is thick, therefore the ratio of epidermis tissue to muscle tissue is small, but in second leg meat or claw meat the part of the muscle tissue becomes thin, therefore the ratio of epidermis tissue to muscle tissue becomes large. Such being the difference, in first leg meat or joint meat shrinkage of the muscle tissue proteins of the meat appears remarkably; on the other hand, in second leg meat or claw meat the shrinkage of the epidermis tissue protein (mainly, collagen) appears remarkably, because shrinkage of the muscle tissue protein seems to be inferior than that of the epidermis tissue protein. That is to say, the difference of the curves of the shrinkage of each parts of the meat seems to be owing to both the quantitative and the qualitative differences of meat protein, especially to differences of the amount of connective tissue. The difference of the amount of connective tissue will be examined in another section of these studies.

2. Difference of heat-shrinkage of different tissue of the leg meat of crab

From the results previously obtained, the curve of heat-shrinkage of the crab leg meat seem to be the sum of the ratio of the shrinkage of muscle tissue protein and epidermis tissue protein which are principal components of the crab leg meat. Here it is important to know the ratio of shrinkage of each unit part respectively of tissue comprising leg meat.

The authors have divided the first leg meat into such the parts as muscle, epidermis and tendon, and the ratios of the shrinkage of each part were estimated.

(1) Sample and experimental method

Each end of the first leg meat of fresh *Paralithodes camtschatica* was cut at the parts of the joint; tendon was removed carefully with a knife. Then the crust was carefully removed shaving with a large knife.

The surface skin of the leg meat was torn off with a knife in direction parallel with the bundles of muscle fiber. The thickness of the surface skin was about 0.5 mm; the muscular part was taken as the remainder when surface skin and tendon had been removed. In order to remove muscle tissue from the back of the surface skin as completely as possible, the surface skin was washed with distilled water, then with 2 % NaCl solution to remove the soluble chemical components after Sasaki.³⁴⁾

The three parts of the leg meat divided were used for the sample.

The ratio of heat-shrinkage of each sample was estimated by the same instrument as that shown in Fig. 25.

(2) Results and discussion

Results obtained are shown in Fig. 27, in which curve I shows the ratio of shrinkage of the surface skin (epidermis), curve II shows that of the muscular part, and curve III that of tendon.

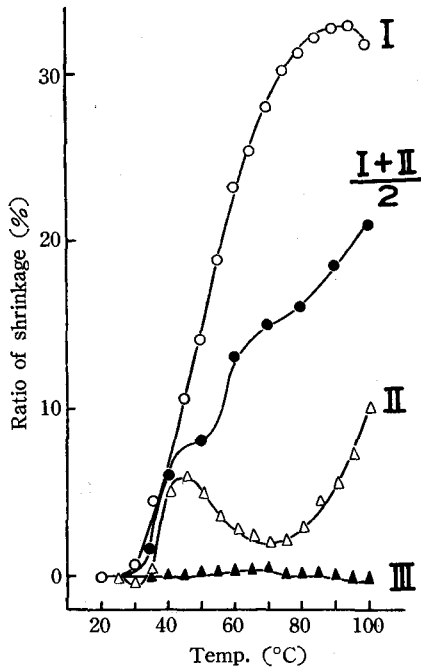

Fig. 27. Variation of the ratios of shrinkage of the different tissues of crab leg meat
 I. Surface skin (Epidermis)
 II. Muscular part
 III. Tendon

As seen in curve I (surface skin) of Fig. 27, rapid shrinkage began at about 30°C, but became slow from about 70°C. At about 95°C, the meat lengthened reversely. In curve II (muscular part), the first step of shrinkage is seen at 35° ~ 45°C. In the range between 50°C and 70°C the meat lengthened reversely. From about 75°C shrinkage began again, to be observed until 100°C. In curve III (tendon), the maximum ratio of shrinkage was observed slightly at about 70°C. To summarize those findings, shrinkage of the surface skin (epidermis) by heating was comparatively rapid and simple; on the other hand the shrinkage of the muscular part showed two steps.

Considering the first step in the curve of shrinkage of muscle tissue which is seen at 35° ~ 45°C, caused by the thermo-vibration of myosin molecule which is filamentous protein, there was formed a net work construction in the myosin molecule; then with rising of the temperature the heat energy increased and the net work construction formed already seemed to be destroyed and the meat lengthened.³⁵⁾³⁶⁾

The fact that in curve I the temperature at which shrinkage began is comparatively low, 30°C, and that there is observed no remarkable step in muscle tissue seemed to be owing to the histological characteristic of the connective tissue which is the main constituent of surface skin (epidermis).

But the fact above described also seem to have a relation with the amount of collagen or shrinkage of collagen fiber by heating. However, in the curves of shrinkage of the surface skin and muscular part showing different types, the opposite phenomena, shrinkage and lengthening, were observed remarkably above 45°C. Therefore, if the mean curve ($\frac{\text{curves I} + \text{II}}{2}$) be drawn from the two curves, there is observed two processes of slow

shrinkage in the ranges of $40^{\circ} \sim 50^{\circ}\text{C}$ and $60^{\circ} \sim 80^{\circ}\text{C}$, and the new curve resembles the curve of the ratio of the heat-shrinkage of the first leg meat (Curve I. in Fig. 26.)

From the discussion above, shrinkage of the various sorts of crab meat samples depends on the shrinkages of the surface skin and muscular part.

3. Difference of the heat-shrinkage of crab meat with the degree of freshness of the meat

According to the results obtained in Experiments VIII and IX in the previous paper³³⁾, the ratio of dehydration or adsorption by heating in water is clarified to differ according to the freshness of the crab meat.

The ratio of dehydration of unfresh meat was larger than that of fresh meat, while the ratio of adsorption was the contrary. Here, the authors report a study on the influence of the freshness of the meat on shrinkage by heating.

(1) Sample and experimental method

From the carcasses which were landed 24 hours after the capture, the second leg meat (with the crust) was removed, and was stored at $5^{\circ} \sim 8^{\circ}\text{C}$ to prepare unfresh samples. Thus the sample having various freshness were made as follows: fresh meat of which volatile basic nitrogen (V.B.-N) was 7.23 mg%, pretty unfresh meat of which V.B.-N

was 15 mg%, and unfresh meat of which V.B.-N was 21.3 mg%. The amount of V.B.-N was estimated by Conway's method. By the use of such sample having various degrees of freshness, shrinkage of the meat by heating was observed as well as in Article 1.

(2) Results

Results obtained are graphed in Fig. 28.

In Fig. 28, curve I shows the ratio of shrinkage of the fresh meat by heating, curve II shows that of pretty unfresh meat and curve III shows that of unfresh meat.

Viewing roughly each curve, one will notice that the ratio of shrinkage of the crab meat once increased with lowering of freshness, but below a definite degree of freshness, the ratio decreased. As to curve I of fresh crab meat, the first and second steps were observed remarkably within ranges of $30^{\circ} \sim$

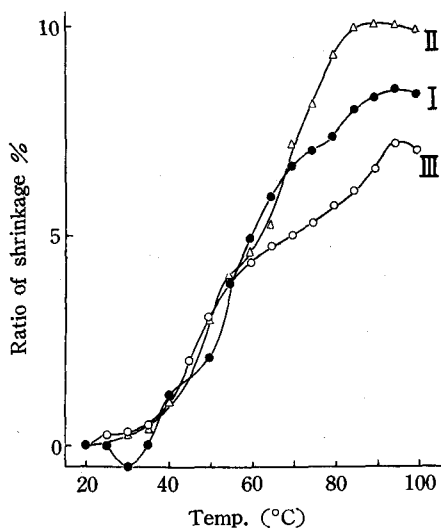

Fig. 28. Variation of the ratios of heat-shrinkage of crab second leg meat having various degrees of freshness

- I. Fresh meat
- △— II. Pretty unfresh meat
- III. Unfresh meat

45°C and 50° ~ 75°C respectively, on the contrary in curve II and curve III which show lowered freshness of the meat, those steps were not remarkable. The difference of shapes of curves I, II and III is considered to be owing to the difference of the ratio of dehydration or adsorption and amount of soluble component dissolved from the meat all which are brought by lowering of freshness.

4. Shrinkage of the meat of various freshness resultant from heating in fresh water or sea water

In this experiment, the authors have studied shrinkage caused by heating of the meat having various degrees of freshness, in order to know how shrinkage is influenced by the difference of the kind of heating water.

(1) Sample and experimental method

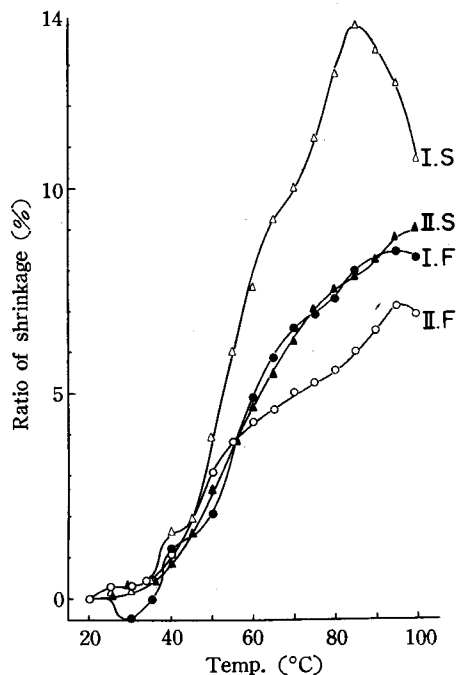

Fig. 29. The heat-shrinkage of the crab second leg meat in fresh water or sea water

- I.F—Heating the fresh meat in fresh water
- △— I.S—Heating the fresh meat in sea water
- ▲— II.S—Heating the unfresh meat in fresh water
- II.F—Heating the unfresh meat in sea water

The second leg meats of which the freshness differed were heated in fresh water or sea water. The fresh meat sample of freshness 10 mg% of V.B.-N, unfresh meat of which freshness was 21.3 mg% were used.

(2) Results and discussion

Results obtained are shown in Fig. 29.

In Fig. 29, curve I.F shows shrinkage of fresh meat by heating in fresh water, curve I.S shows that of fresh meat in sea water; curve II.F shows that of unfresh meat in fresh water, curve II.S shows that of unfresh meat in sea water. As shown by those curves, the ratio of shrinkage in sea water, in spite of freshness of the sample, was larger than in fresh water.

In the case of heating the fresh meat in fresh water, as observed above in the heating in distilled water, the first and second steps were observed the temperature ranges of 35° ~ 45°C and 50° ~ 75°C respectively, also in fresh or sea water. However, in the sea water, the second step was observed at the range of 45° ~ 70°C. On the one hand, in the curve of shrinkage of unfresh meat by

heating in fresh or sea water, there were not observed remarkable two steps different from fresh meat, as well as in Experiment 3 described above. The fact that the ratio of the shrinkage of the meat by heating in sea water is larger than that in fresh water, and in the case of heating above 85°C, the meat lengthens as observed in curve I.S, agrees with Shimidu's results.²³⁾ He found that in the curve of the ratio of dehydration (or heat-coagulation curve) of heated fish meat, the ratio of dehydration of the heated fish meat in NaCl solution is larger than that in fresh water, and that the peak in the curve of dehydration is influenced by the addition of an electrolyte (*e.g.*, NaCl), and it becomes sharp.

According to Takahashi *et al.*,¹⁹⁾ when shark skin is heated at a definite temperature (50°C) in fresh water, with the passage of heating time it begins to shrink, and after that it lengthens reversely; on the contrary, when the shark skin is heated in NaCl solution, there is observed no lengthening after the shrinkage. In the former case the net work construction formed (as result of the formation of the net work, shrinkage occurs) in collagen protein molecules caused by heat vibration of collagen molecules, will dissociate with the increasing of heat energy by length of heating time, consequently the lengthening of the meat will occur. In the latter case, by heating in NaCl solutions, as ionic binding will be formed besides the mutual binding among net work constructions; the dissociation of net work construction will be caused to occur not easier than the former with increasing of heat energy after the shrinkage, therefore there is observed no remarkable lengthening after the shrinkage.

5. Difference of the ratio of shrinkage from the various pH of boiling water

The authors have known that the solubility, ratios of swelling and dehydration were varied remarkably by the different value of pH.

Here the author record their observations of the change of the ratio of shrinkage by heating in water having different values of pH.

(1) Sample and experimental method

Fresh second leg meat of *Paralithodes camtschatica* was heated in the solution having various values of pH which were adjusted by 0.1 N HCl or 0.1 N NaOH solution; the change of ratio of shrinkage of the meat was observed in the same way as in the previous experiment.

(2) Experimental results

Results obtained are shown in Fig. 30.

In Fig. 30, curves I ~ VI show the variation of the ratio of shrinkage of the meat caused by heating in solutions of pH 3.5, 5.1, 6.8, 8.0, 9.5 and 11.9, respectively. In general, in Fig. 30, it was observed that shrinkage occurred rapidly and the ratio of

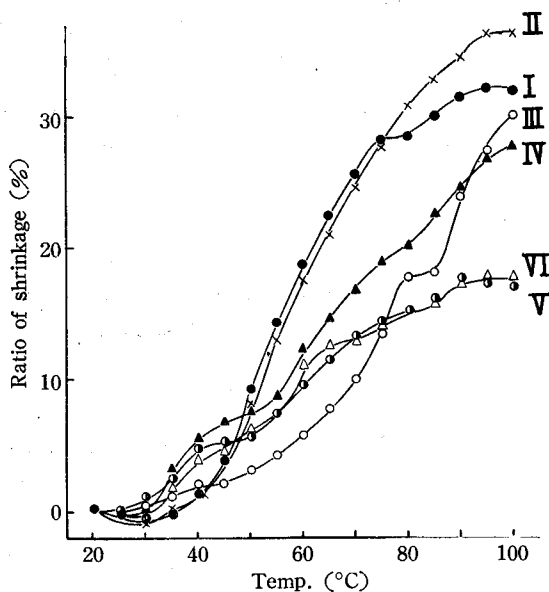

Fig. 30. The heat-shrinkage of the crab second leg meat in water having various pH values

I. pH 3.5, II. pH 5.1, III. pH 6.8
IV. pH 8.0, V. pH 9.5, VI. pH 11.9

slightly observed.

The fact that curve II of pH 5.1 shows comparatively larger ratio of shrinkage of the meat than other curves, and on the curve that there is observed no variation of the shrinkage may have some relation with the fact noted in the previous articles IV, that the isoelectric points of crab flesh proteins were at pH 4.5~5.0, and that the degree of swelling and the ratio of dehydration of crab meat protein were of minimum and maximum value at about pH 5, respectively. When the crab meat is heated in the solution of about pH 5, the meat protein shows isoelectric reaction, and the meat protein begins to coagulate before the heating; therefore remarkable shrinkage of the main proteins in the meat may not occur. The fact that curve II of pH 5.1 in Fig. 30 is situated in higher position than in curve I in Fig. 27 which shows the ratio of shrinkage of surface skin of crab meat, is suggested to be owing to the reason that in curve II in Fig. 30, the phenomenon of the shrinkage of the crab meat does not only show owing to the isoelectric reaction above described, but also to the fact that the surface skin of the crab meat, or collagen in the connective tissue among the bundles of muscular fibers show the isoelectric reaction at pH 5, and therefore the ratio of shrinkage of the meat increases owing to the coagulation of collagen. This suggestion will be supported by the fact later described that the isoelectric point of the collagen in the crab meat is pH 5 ~ 6, and in that range of pH the degree

shrinkage was large on the acidic side, but it occurred slowly and the ratio was small on the alkaline side. The ratio of shrinkage once increased above pH 7.0, but it decreased on the high alkaline side as observed in curve V of pH 9.5 and in curve VI of pH 11.9.

In curve III to VI which show the ratio on the alkaline side, there are observed the first and second processes of shrinkage in the ranges of 30° ~ 50°C and 50° ~ 85°C (the difference of the range of the temperature may be somewhat granted), but in curve II which shows the ratio in the acidic side the first and second processes were not remarkable, and in curve I one stage of the shrinkage at 75° ~ 80°C was only

of the swelling of collagen shows the minimum.

The fact that above pH 8.0 the ratio of shrinkage of the crab meat decreases, will have some relation to the fact that the dissolving amount of crab meat protein increases above pH 8.

XI. COLLAGEN IN THE CRAB MEAT

From the obtained results described in the previous Article II³³⁾ of these studies, the histological construction of crab leg meat was ascertained to be different from that of fish meat. In crab leg meat, it was observed that at the inner side of the surface skin which is like connective tissue, many blocks of muscular fiber bundles are arranged, with the chinks between blocks occupied by connective tissues. (Ref. Fig. 3 in Article II, in the previous paper.³³⁾) Those histological characteristics of the crab meat are considered to have intimate relations with degree of the swelling, ratio of dehydration or the ratio of the shrinkage resultant from heating.

In this article, the authors report studies on the collagen which is main protein in connective tissue in crab meat.

1. Amounts of collagen, mucin and elastin in crab meat

The amounts of collagen, mucin and elastin in crab leg meat including surface skin were measured.

(1) Sample

Raw leg meat from the fresh carcass of crab (*Paralithodes camtschatica*) was removed from the crust with a large knife; it was frozen (at -20°C), and then was brought to the laboratory. After defrosting at room temperature, the leg meat was used for the sample. As control, frozen chum salmon meat was used as well as the crab meat.

(2) Experimental method

Each 50 g of the crab leg meat and salmon meat which were crushed with a mixer were treated according to the following scheme (Scheme 2) after Takahashi's¹⁹⁾ and Sasaki's³⁴⁾ methods. Insoluble components in the meats were fractionated in some groups. The amounts of nitrogen of collagen (as gelatine), mucin and elastin were estimated by the micro-Kjeldahl method.

(3) Results

Results obtained are shown in Table 5.

As seen in Table 5, the amounts of collagen and mucin in crab meat were larger than those in salmon meat; in the dried matter the amounts of both components in the former were about three times those in the latter.

On the other hand, the amount of elastin in crab leg meat was 0.035 % for the raw meat (0.096 % in the dried matter), but it was 0.159 % for the raw salmon meat

Scheme 2. Method for classification of water insoluble protein from crab meat

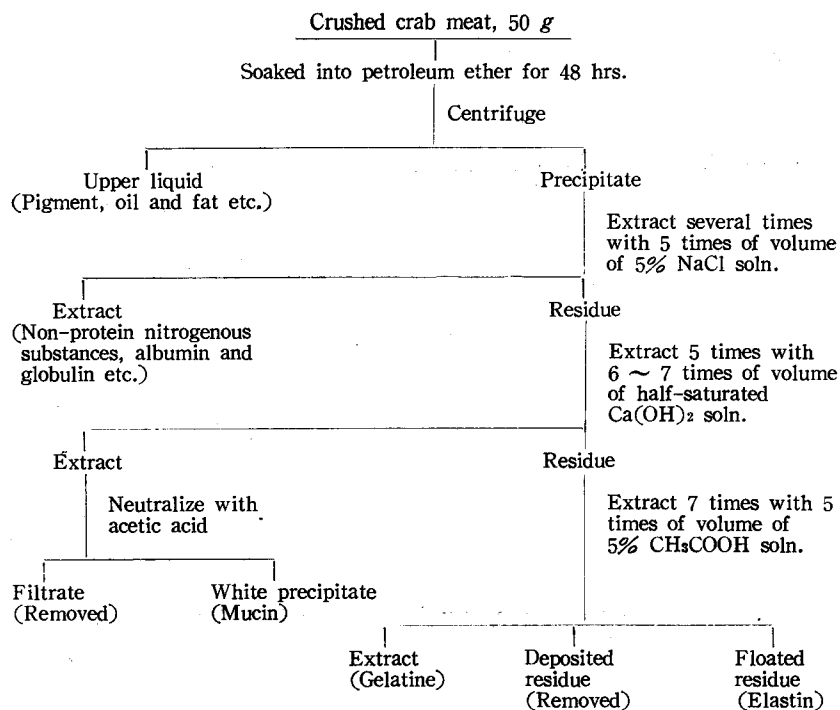

Table 5. Amounts of collagen and mucin in crab leg meat and salmon meat

Sample	Crab meat (leg)	Salmon
Water content in raw meat (%)	81.83	78.68
Total-N in raw meat (%)	2.73	3.59
Gelatine-N	In raw meat (%)	0.059
	In dried material (%)	0.324
	In Total-N in raw meat (%)	2.160
Mucin-N	In raw meat (%)	0.031
	In dried material (%)	0.171
	In total-N in raw meat (%)	1.130
		0.408

(0.377 % in the dried matter). That is to say, the amount in the crab meat was smaller than in the salmon meat. According to Tanikawa,¹⁴⁾ the amount of collagen in crab meat was smaller than in sea cucumber or squid meat, but it was larger than in fish meat. In sea cucumber meat, the amount of collagen was 1.4 ~ 3.0 % of the total amount of the protein in the meat, whilst in flat fish or carp meat it was about 0.83 or 0.52 %,

respectively; those amounts were as the same as in salmon meat. The amount of collagen in the crab leg meat showed about 2 %, of which the value is mid-way between the amounts in sea cucumber meat and fish meat. The result observed in the previous Article, III, the curve of the ratio of dehydration of crab meat is situated between the curves of sea cucumber and fish meats may have an intimate relation with the different amount of collagen owing to the histological characteristics which are responsible for different characteristics in the dehydration, the swelling or the shrinkage by heating.

2. Amount of collagen in the surface skin of crab leg meat and muscular part

(1) Sample

After the defrosting of the frozen crab meat in the same manner as in the previous experiment, the defrosted leg meat was divided by a knife into surface skin (epidermis) and muscular part. The two portions (parts) were washed with distilled water, and then with 5 % NaCl solution to remove the soluble components as completely as possible. After the washing, the water attached to the skin or the muscular part was removed by absorption pressing with a filter paper. The skin was directly crushed. The tendon was removed from the muscular part. After that, the muscular part was crushed.

(2) Experimental method

Each 10 g of each sample was put into respective 200 cc flasks, and 100 cc of 2 % acetic acid solution was added to the flask which was plugged with cotton, and heated at 110°C for 90 minutes in a retort. After collagen in each part of the meat has changed to gelatine by the heating, 20 % trichloroacetic acid was added to the heated substance in order to remove the protein. After precipitating the protein, the solution was filtered.

The amount of collagen nitrogen was estimated with the filtrate according to Kashiwada and Kakimoto³⁷.

(3) Results

Results obtained are shown in Table 6.

Table 6. Amount of collagen in crab leg meat and muscular part respectively

Sample	Surface skin	Muscle meat
Water content in raw material (%)	80.48	82.85
Total-N in raw material (%)	1.103	1.865
Gelatine-N	In raw material (%)	0.035
	In dried material (%)	0.182
	In total-N	3.173
		2.04

From Table 6, the total amount of collagen nitrogen in the surface skin will be seen

to be smaller than in the muscular part, but the ratio of the amount of collagen nitrogen to the total amount of nitrogen in the surface skin is larger than in the muscular part, though the difference is small. In the experiment on the shrinkage of the meat by heating, it was observed that in the curve of the shrinkage of the surface skin there was indicated a remarkable shrinkage (Ref. Fig. 27).

This result is considered to be difficult to explain from the difference of the amounts of collagen in the two parts of surface skin and muscular.

This may be explained by the fact that the shrinkage of collagen fiber in muscle is smaller than that of muscular fiber itself. But this explanation is insufficient, therefore the matter will be studied in future.

3. Amino acids in collagen in crab meat

Takahashi *et al.*¹⁹⁾ and Neuman *et al.*²⁸⁾ have studied the composition of amino acids in the collagen of shark skin and cod skin respectively.

They have suggested that there is a proportional relation between the amount of hydroxyproline and the thermotolerance (the degree of the beginning temperature of the shrinkage by heating) of the fish skin. The authors have studied the nitrogen distribution of collagen in the crab leg meat in order to learn the characteristics in physical and chemical properties of the crab meat.

(1) Sample

Fresh crab leg meat was rapid-frozen (at -20°C) and brought to the laboratory. After defrosting, the crust and tendon were removed.

The leg meat including surface skin was crushed. Collagen was prepared from the crushed meat according to Sasaki's method shown in Scheme 3.

(2) Experimental method

The prepared collagen (0.5 g of dried matter) was hydrolyzed by 20 % sulfuric acid solution, and the nitrogen distribution was examined with the hydrolyzate by Van Slyke's method. A part of the hydrolyzate was neutralized by baryta and was filtered. The filtrate was concentrated in vacuum.

The concentrated solution was used for two dimensional paper chromatography. The developing reagents were butanol, acetic acid and water (4:1:2), and phenol and water (5:1)⁴⁰⁾ at room temperature for 15 hours.

The revealing reagent was ninhydrin-butanol solution. Revealed amino acids were identified.

(3) Results

The nitrogen distribution of collagen obtained by Van Slyke's method is shown in Table 7 in which the data as collagen of cowhide⁴¹⁾ were also presented.

Comparing nitrogen distribution of collagen in crab meat with that in shark skin²⁴⁾

Scheme 3. Method for preparation of collagen from crab meat

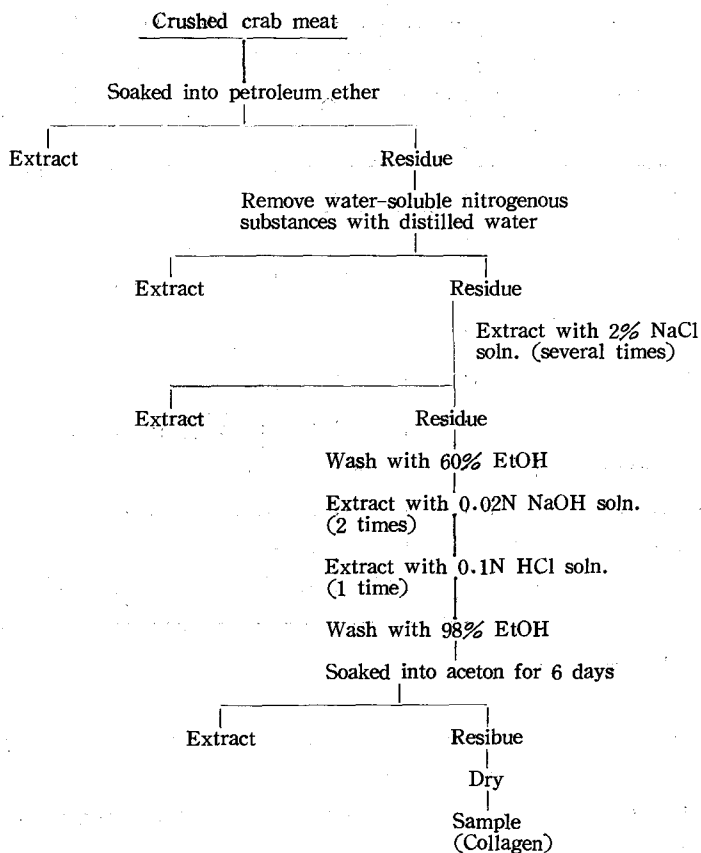

or cowhide,⁴¹⁾ the amount of amide nitrogen in collagen of the former is smaller than that of latter two. The amount of humin nitrogen of the former is larger than that of the latter two. The total amount of nitrogen in mono-amino acids fraction in collagen of the former was only about 52 % of the total amount of nitrogen; on the other hand, the ratio of the latter two showed about 56 %. The ratio of the former is slightly smaller than that of the latter two materials. As to the amount of amino acid nitrogen in di-amino acids fraction (arginine, histidine, lysine etc.), there is no remarkable difference between the former and the latter two.

In the collagen of crab meat, there was observed the presence of glycine, cystine, threonine, arginine, aspartic acid, oxyproline and proline as the component amino acids.

4. Isoelectric reaction of collagen of crab leg meat

In this experiment, the titration curve of collagen of crab meat was estimated, and the isoelectric point was examined.

Table 7. Nitrogen distribution in collagen of crab meat

N-fraction	Sample	Collagen of crab		Collagen of shark skin	Collagen of cowhide
		In raw material (mg%)	In total-N (%)	In total-N (%)	In total-N (%)
Total-N		61.51	100		
20 % H ₂ SO ₄ soluble-N		60.92	99.10		
20% H ₂ SO ₄ insoluble-N		0.59	0.97		
Amide-N		1.16	1.88	3.47	2.90
Humin-N		2.54	4.14	0.48	0.59
Di-amino fraction total-N		25.43	41.40		
Di-amino fraction amino-N		13.90	22.60	Arginine Histidine Lysine } 25.1	23.97
Di-amino fraction non-amino-N		11.53	18.70		
Mono-amino fraction total-N		31.79	51.65	55.9	56.84
Mono-amino fraction amino-N		15.68	25.45		
Mono-amino fraction non-amino-N		16.11	26.20	14.1	65.63

(1) Sample and experimental method

The prepared collagen of crab meat from the previous experiment, 3, was used for the estimation of the isoelectric point of the protein according to the method of Bowes *et al.*⁴²⁾

Each 0.05 g of samples of the prepared collagen of crab meat was weighed and added into 100 cc volume flasks. Into each flask 40 cc of the various pH solutions which were adjusted by N/100 HCl or NaOH solutions were added. After the flasks were plugged, they were stored at 15°C for 72 hours. After standing, each content was filtered. A definite amount of filtrate was titrated with N/100 HCl or N/100 NaOH solutions by using phenol purple as an indicator. pH value of a part of the filtrate was measured by a glass electrode meter. As control, one flask to which distilled water was added instead of the buffer solutions was treated in the same manner as above described. The differences of the titrated amount between the samples and the control were considered to be the amounts of N/100 HCl or N/100 NaOH solutions which were reacted with collagen.

From those results, the amounts of N/100 HCl or N/100 NaOH solutions which were bound with 1 g of collagen in each crab meat sample were calculated, and the titrating curve was drawn from the relation between the bound amounts and pH value.

(2) Results

Results obtained are shown in Fig. 31

As seen in Fig. 31, collagen bound about 0.28 mMol HCl at pH 3.0 in acidic side.

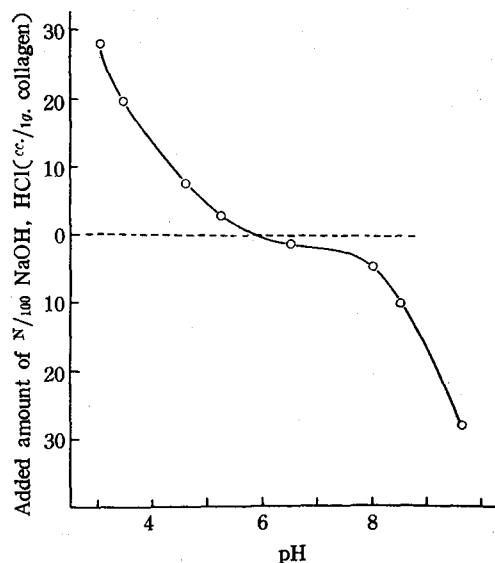

Fig. 31. Titrating curve of collagen of crab leg meat

With increasing of pH value, the binding amount with HCl decreased, the collagen bound about 0.03 mMol HCl at pH 5.25, and with further increasing of pH value, it bound with 0.015 mMol of NaOH.

Above pH 8.0 the binding amount with NaOH increased rapidly, and at pH 9.6 it bound with 0.28 mMol of NaOH. Therefore from Fig. 31, the isoelectric point of collagen of crab meat was clarified to be pH 5.3 ~ 6.5.

This result agrees with that for collagen of cowhide (pH 5.5 ~ 6.5), obtained by Bowes⁽⁴²⁾.

5. Degree of the swelling of collagen in crab meat in various solutions

In Experiment VII in the previous paper, the present authors have studied the swelling of the crab meat itself. According to the results obtained, the crab meat swelled remarkable in acidic solution below pH 4.0 or in alkaline solution above pH 9.0, and the condition of the swelling of the crab meat was observed to be similar to that of collagen of fish skin or that of cowhide. This result suggested to the authors that collagen of crab meat tissues will take an important rôle in the swelling of the crab meat itself. In order to ascertain the point, examination was made of the swelling of collagen of crab meat in solutions having various pH values.

(1) Sample and experimental method

Portion of prepared wet collagen of crab meat obtained in the previous experiment, 3, was used for the sample. The estimation of the swelling was carried out by the following method after Svedberg's centrifugal method. Each 2 g of the wet collagen of crab meat was put into 10 cc volume small test tube with scales. After the precipitation of the centrifuged collagen (3,000 r.p.m. for 20 minutes), the volume of the precipitated collagen was measured. Then each 5 cc of various buffer solutions adjusted by N/100 HCl or N/100 NaOH to have various pH value, was put in the test tube. Next, the test tubes were plugged, and stored for 48 hours in cold storage in order to swell the collagen in the tube. After storage, the collagen was made to precipitate again by a centrifuge (3,000 r.p.m. for 20 minutes). The volume of the precipitated collagen was measured.

Then pH value of a part of the upper transparent liquor was estimated by a glass electrode meter. The degree of the swelling (S) was calculated by the following equation.

$$S = \frac{V}{V_0} \dots\dots(1)$$

Here, V_0 is the initial volume of collagen, and V is the volume after the swelling.

(2) Results

The degree of swelling of collagen of crab meat in various pH solutions is shown in Fig. 32.

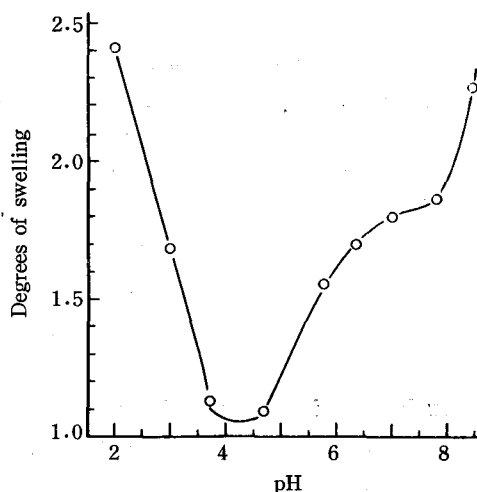

Fig. 32. Relation between pH values and the degree of the swelling of collagen of crab meat

As seen in Fig. 32, collagen of crab meat showed the minimum value of degree of swelling at about pH 4.7; the degree increased in acidic side below pH 4, or in alkaline side above pH 5. The tendency shown in the swelling curve agrees with that of crab meat itself (Ref. Fig. 14 in the previous paper.⁸³⁾). Therefore the collagen fiber which is a kind of protein in the connective tissue in crab meat has remarkable influence upon the swelling in addition the dehydration, the shrinkage by heating or heat coagulation of the meat.

Also in fish meat, it is known that the value of the degree of the swelling shows comparative high value in acidic or alkaline sides. This may be owing to the presence of acidic and basic amino acids which are contained more or less in protein molecules. According to the results obtained by the present authors, in Atka mackerel¹³⁾ or Suketo-cod meat,¹¹⁾ the degree of the swelling increases with the shift of pH value to acidic or alkaline sides from the isoelectric point of the meat. But the increase in the swelling in the fish meat was not so large as that of crab meat itself or of collagen of crab meat.

DISCUSSION AND SUMMARY

Since the perfection of so called "low temperature boiling method" has been completed in order to make canned boneless crab meat or to prevent the blueing of canned crab meat, the present authors have been obliged to find out about shrinkage of the crab meat by heating and the properties of the collagen of crab meat. The results obtained are discussed and summarized as follows:

(1) In the results obtained as to the shrinkage of the crab leg meat by heating:

(i) On the curve of the shrinkage of first leg meat (round meat) or joint meat (so-

called scallion type meat), there were observed 3 steps at three ranges of 40° ~ 50°C, 70° ~ 80°C and 95° ~ 100°C. Former two ranges of them seemed to correspond to the heat-coagulating temperature of myosins and myogens, respectively which are component proteins in the muscle of the crab meat.

(ii) With change in the material from second leg meat (so-called pepper type meat) to claw meat, shrinkage step became not remarkable on the curve. The ratio of shrinkage by heating increased throughout the range of the heating temperature, and the beginning temperature of the first shrinkage process move to a lower point.

(iii) Comparing the shrinkage of the crab meat as to each unit of the component tissue, the surface skin (epidermis) began to show shrinkage rapidly and simple, at lower temperature, 30°C, and there was observed no remarkable step at the range of 30° ~ 90°C; the curves of muscular part from which surface skin had been removed showed the presence of two principal protein groups which begin to shrink at 35° and 70°C.

(iv) From the results above described, shrinkage of the crab leg meat by heating has occurred as a result of the cooperated shrinkage of muscular protein and surface skin protein.

(v) The degree of the shrinkage of the crab meat was influenced by the freshness. With lowering of the freshness, the first and second processes of shrinkage became not-remarkable on the curve of the shrinkage by heating.

(vi) The ratio of shrinkage of the crab meat heated in sea water was larger than that in fresh water. On the curves of shrinkage of the fresh crab meat, two stages of shrinkage were observed in the meats whether heated in fresh water or in sea water.

(vii) If the pH value of the heating water is pH 5 which is the isoelectric point of the crab meat protein, there results a comparatively simple and sharp curve of the shrinkage by heating. This may be due to the coagulating shrinkage of meat proteins at the isoelectric point.

(viii) In the alkaline side, with the increase of pH value, the ratio of shrinkage by heating decreased, but each stage of the shrinkage was observed on the curves as well as when the material was heated in fresh water.

(2) The shrinkage of the crab leg meat was considered to be influenced by the shrinkage of the surface skin. The surface skin consists mainly of connective tissue. Accordingly, the properties of collagen in the crab meat were studied.

(i) The amount of collagen in crab leg meat containing surface skin was clarified to be midway between that in sea cucumber or squid and that in fish meat.

The amounts of mucin or elastin of the former two were smaller than those of the latter.

(ii) There was no remarkable difference in the amount of collagen between the surface skin and muscular part. The amount of the former was slightly larger than that of the

latter. This is owing to the fact that also in the muscular part there is a large amount of connective tissue. This observation agrees with the result of histological observation.

(iii) Collagen was isolated and of it the nitrogen distribution and the composition of amino acids were examined. According to the results obtained, the amount of nitrogen in monoamino acids and diamino acids fractions in collagen of crab meat was the same as that of shark skin or cowhide. The presence of glycine, cystine, threonine, arginine, aspartic acid, oxyproline and proline was detected.

(iv) By examining the titrating curve of collagen of crab leg meat, the isoelectric reaction was clarified to be in the range pH 5.3 ~ 6.5.

(v) By examining the reaction between the swelling and pH value, the minimum degree of the swelling was shown to occur at pH 4.7, whilst it was observed to increase at pH 2 or above pH 8.0. Those results were considered to be the same as those in general collagen fiber.

Literature cited (Continued)

- 33) Tanikawa, E., Wakasa, T. & Nagasawa, Y. (1958). *Bull. Fac. Fish., Hokkaido Univ.* 9 (3), 227.
- 34) Sasaki, R. & Sato, Y. (1954). *J. Agr. Chem. Soc. of Japan* 28, 510.
- 35) Neurath, H. (1944). *Chem. Rev.* 34, 157.
- 36) Wu, H. (1942). *J. Biol. Chem.* 142, 249, 265.
- 37) Kashiwada, K. & Kakimoto, D. (1952). *Bull. Jap. Soc. Sci. Fish.* 18 (5), 17.
- 38) Neuman, R. E. (1949). *Arch. Biochem.* 24, 289.
- 39) ————— & Logan, M. A. (1949). *J. Biol. Chem.* 184, 299.
- 40) Chemical Society of Japan. (1957). *The Chemical Experiment* 23, 234.
- 41) Stiasny, H. (1931). "Gerbereichemie".
- 42) Bowes, J. H. & Kenten, R. H. (1948). *Biochem. J.* 43, 358.