



HOKKAIDO UNIVERSITY

Title	CHEMICAL STUDIES ON THE MEAT OF ABALONE (<i>Haliotis discus hannai</i> INO)- I
Author(s)	TANIKAWA, Eiichi; YAMASHITA, Jiro
Citation	北海道大學水産學部研究彙報, 12(3), 210-238
Issue Date	1961-11
Doc URL	https://hdl.handle.net/2115/23140
Type	departmental bulletin paper
File Information	12(3)_P210-238.pdf



CHEMICAL STUDIES ON THE MEAT OF ABALONE

(*Haliotis discus hannai* INO)—I

Eiichi TANIKAWA and Jiro YAMASHITA*

Faculty of Fisheries, Hokkaido University

There are about 90 existing species of abalones (*Haliotis*) in the world, of which the distribution is wide, in the Pacific, Atlantic and Indian Oceans.

Among the habitats, especially the coasts along Japan, the Pacific coast of the U.S.A. and coasts along Australia have many species and large production.

In Japan from ancient times abalones have been used as food. Japanese, as well as American, abalones are famous for their large size. Among abalones, *H. gigantea* ("Madaka-awabi"), *H. gigantea sieboldi* ("Megai-awabi"), *H. gigantea discus* ("Kuro-awabi") and *H. discus hannai* ("Ezo-awabi") are important in commerce.

Abalone is prepared as raw fresh meat ("Sashimi") or is cooked after cutting it from the shell and trimming the visceral mass and then mantle fringe from the large central muscle which is then cut transversely into slices. These small steaks may be served at table as raw fresh meat ("Sashimi") or may be fried, stewed, or minced and made into chowder.

A large proportion of the abalones harvested in Japan are prepared as cooked, dried and smoked products for export to China.

Dried abalone has been used as an elixir of life as well as dried sea cucumber from ancient times in China. The abalone is also prepared for canning, after its removal from the shell, by cutting away the visceral mass.

However, there are few chemical studies on the meat of abalone¹⁾, especially on the protein of the meat.

The authors have studied the fundamental chemical properties of the meat of abalone, in order to solve technical problems in the procedures of processing various kinds of manufactured merchandise.

For this study *Haliotis discus hannai* ("Ezo-awabi") was employed. *H. discus hannai* resembles *H. gigantea* ("Madaka-awabi") in appearance, but the former differs from the latter in the thin shell, sharp peristome and long oval shape of the shell, on the surface of which 3-4 lines of spiral lip appear in young stage and the greater height of the respiratory pore. The color of the surface

*Present adress: Laboratory of Daiwa Can Co. Ltd., Shimizu, Shizuoka Prefecture, Japan.

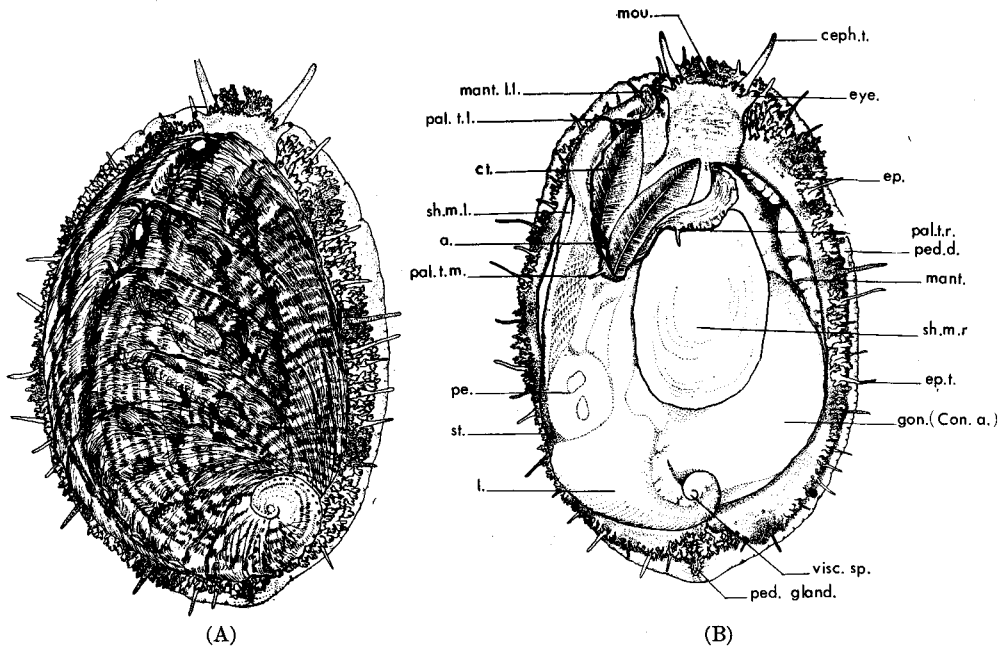

Fig. 1. Appearance of abalone (*H. discus hannai* INO)

a.; Anus
 ceph. t.; Cephalic tentacles
 ct.; Ctenidium
 ep.; Epipode
 ep. t.; Epipodial tentacles
 eye; Eye
 gon.; Gonad
 (Con. a.; Conical appendage)
 l.; Liver
 mant.; Mantle
 mant. l. l.; Anterior left lobe of mantle

mou.; Mouth
 pal. t. l.; Left pallial tentacle
 pal. t. m.; Median pallial tentacle
 pal. t. r.; Right pallial tentacle
 pe.; Pericardial cavity
 ped. d.; Dorsal surface of foot
 ped. gland.; Pedal gland
 sh. m. l.; Left shell muscle
 sh. m. r.; Right shell muscle
 st.; Stomach
 visc. sp.; Visceral spire

shell of *H. discus hannai* is dark green or brown while the interior of the shell is very brilliantly colored mother-of-pearl having green color. The long diameter of the shell is about 100 mm, the short diameter is about 65 mm, and the height is about 20 mm.

H. discus hannai has been considered to be one variety of *H. gigantea*. But recently it has come to be considered to be different species from *H. gigantea*. The distribution of *H. discus hannai* is wide: Honshu, Pacific coasts of Tohoku district, western coasts of Hokkaido, eastern coasts of Korea and seas around Sagalein, Kuril Islands, Kamchatka Peninsula, Aleutian Islands and Alaska Peninsula.

The spawning season of *H. discus hannai* is September~October in Iwate

and Aomori Prefectures of Honshu, and September~November in southern waters of Hokkaido. This species lives on rocks in shallow seas, to the depth of 13 fathoms. The molluscs creep about on the bottom feeding on kelp and other seaweeds.

In Iwate Prefecture, it is permitted to take abalone above 10 cm in size during a definite period from autumn to winter. Those limits are set for conserving the source. The size of the shell of the old abalone sometimes reaches to 180~200 mm. The principal food of the abalone is brown algae or red algae. Sometimes they eat green algae. Other foods which have been detected in the stomach of the abalone are diatoms, copepoda, cirripedia, chaetopoda, and hydrozoa.

I. SEASONAL VARIATION OF CHEMICAL COMPOSITION OF THE ABALONE MEAT

In order to ascertain seasonal variation of chemical composition, the abalone meat was analyzed quantitatively once a month. The living abalones (*H. discus hannai*) of which the size was almost equal (long diameter of the shell greater than 10 cm), were used as samples.

1) Experimental method

Living abalones (*H. discus hannai*) which were caught in the seas near Hakodate, Hokkaido, were used. The body was cut from the shell, crushed homogeneously and used as sample. Estimated items were water content, protein, fat, ash, and glycogen.

2) Results

The results obtained are shown in Figs. 2 and 3.

As seen in Fig. 2, the amount of water-content in the meat decreased gradually from June to the minimum (72.1%) in August. Thereafter it increased gradually to 77.9% in October. In December it decreased again and then increased. Similarly to the amount of water-content the amount of ash decreased rapidly from June to August and showed the minimum value (1.2%) in August. It increased in November, but decreased again in December, and thereafter it increased gradually. Therefore, the curves of the variations in amounts of water-content and ash are similar.

But the variations of the total amount of nitrogen, amount of protein-nitrogen and the amount of crude fat were seen to be the reverse. The total amount of nitrogen increased gradually from June to the maximum amount (3.1%) in August and September, and then decreased in October; thereafter the amount was almost uniform. The amounts of protein-nitrogen and crude fat exhibited almost the same tendency of variation, though, of course, the amounts were different.

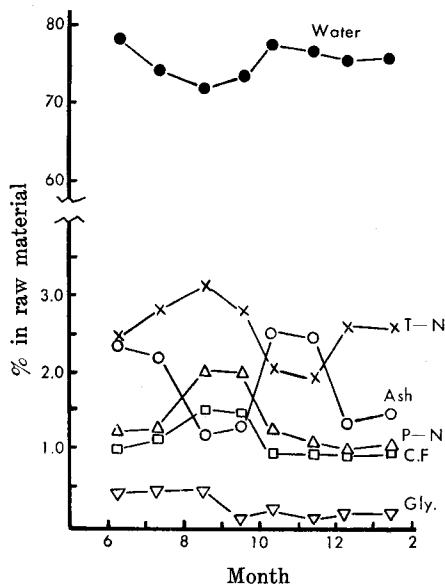

Fig. 2. Seasonal change of proximate composition of *H. discus hannai* meat in raw material

- Water-content
- Ash
- ×— Total-N
- △— Protein-N
- Crude fat
- ▽— Glycogen

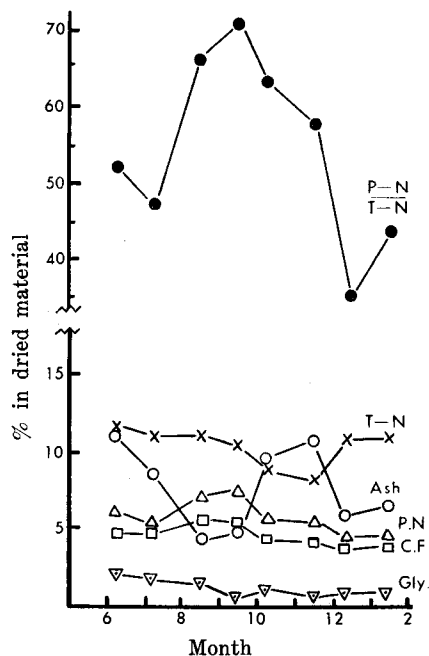

Fig. 3. Seasonal change of proximate composition of *H. discus hannai* meat in dried material

- Protein-N/Total-N (%)
- Ash
- ×— Total-N
- △— Protein-N
- Crude fat
- ▽— Glycogen

As to the amount of glycogen, it showed the maximum in July and August, but it decreased in September or November.

As seen in Fig. 3 showing the seasonal change of proximate composition of abalone in dried matter, the total amount of nitrogen in the dried matter decreased from June to November, but it rapidly increased in December.

The amount of protein-nitrogen in the dried matter showed the maximum (7.6%) in August and September with decrease to 4% in December. Therefore the ratio of the amount of protein-nitrogen to the total amount of nitrogen showed the maximum (70%) in September, and the minimum (36%) in December. The amount of fat in the dried matter registered generally no remarkable change but it showed somewhat of decrease from October to December. The amount of glycogen showed no remarkable change but it decreased more or less in September.

In view of the results above reported, the proximate composition of abalone

meat is principally different according to the fishing period. Of course, it will be different according to the kinds of abalone and fishing places.

As seen in the results obtained, the chemical composition changed remarkably from September to October. This is considered to be a reserving period for the spawning. After the spawning the percentages of chemical components generally temporarily decreased, but with the lapse of the time, the amounts recovered.

II. NITROGEN DISTRIBUTION OF ABALONE MEAT

1. Nitrogen distribution of raw abalone meat

1) Experimental method

Meat of fresh abalone caught near Hakodate, was removed from the shell. The visceral mass was discarded and mantle fringe was also trimmed. The large central muscle was minced and employed as the sample.

Five g of the minced abalone meat was hydrolyzed with 20% HCl for 48 hours. A part of the hydrolyzate was used for the detection of the amino acids by two-dimensional paper chromatography, and the rest was used for the determination of the nitrogen distribution by Van Slyke's method.

As the solvent in the paper chromatography, phenol containing 10% water

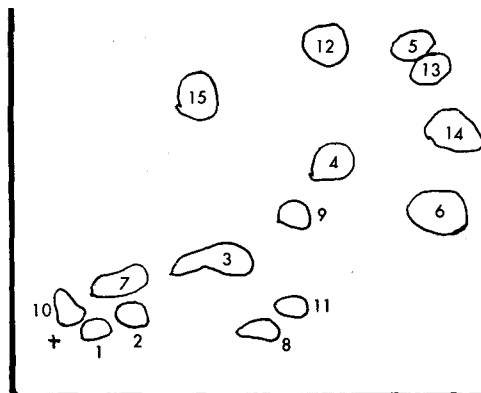

Fig. 4. Paper chromatograms of amino acids in *H. discus hannai* meat (Hydrolysis with 20% HCl)

- | | |
|------------------|------------------------|
| 1. Aspartic acid | 9. Hydroxyproline |
| 2. Glutamic acid | 10. Cystine |
| 3. Alanine | 11. Histidine |
| 4. Valine | 12. Tyrosine |
| 5. Phenylalanine | 13. Leucine |
| 6. Proline | 14. Methionine |
| 7. Serine | 15. 3-5-diiodotyrosine |
| 8. Lysine | |

was first used, and then lutidin: aniline: water (65:7.2:28) was used. As spraying reagent butanol solution of ninhydrin was employed.

2) Results

The results with respect to the kinds of amino acids detected by the paper chromatography are shown in Fig. 4, and the nitrogen distribution determined by Van Slyke's method is shown in Table 1.

Table 2 shows the comparison of nitrogen distribution of other fish and shell

Table 1. Nitrogen distribution of *H. discus hannai* meat

Fraction	g in 100 g of sample	% to total-N
Total-N	2.840	100
20% HCl insoluble-N	0.113	3.97
20% HCl soluble-N	2.725	96.03
Amide-N	0.143	4.06
Humine-N	0.040	1.14
Basic total-N	0.989	34.80
Arginine-N	0.546	19.20
Histidine-N	0.186	6.54
Lystine-N	0.232	8.20
Cystine-N	0.024	0.85
Basic amino-N	0.208	7.32
Mono amino acid total-N	1.621	57.17
Mono amino acid amino-N	1.459	51.42
Mono amino acid non-amino-N	0.163	5.75
Total	2.896	101.14

Table 2. Comparison of nitrogen distribution of meat of marine creatures

Fraction	Sample	Squid (dried)	Atka mackerel	Sea cucumber	Abalone
Total-N (Per dry matter)		12.60	15.98	9.53	10.59
Amide-N		4.09	5.36	3.43	4.06
Humine-N		3.33	5.14	11.47	1.14
Basic total-N		39.70	26.13	22.40	34.80
Arginine-N		20.00	8.65	11.16	19.20
Histidine-N		8.74	8.71	9.43	6.54
Lysine-N		10.07	7.85	0.82	8.20
Cystine-N		0.92	0.91	0.93	0.85
Mono amino acid total-N		52.80	56.56	56.70	57.17
Mono amino acid amino-N		43.00	46.22	42.15	51.42
Total		99.92	98.85	98.80	101.14

fish meat (Atka mackerel²⁾, squid³⁾, sea cucumber⁴⁾).

As seen in Table 1 and Fig. 4, aspartic acid, glutamic acid, alanine, valine, phenylalanine, proline, lysine, serine, methionine, hydroxyproline, 3-5-diodotyrosine were detected. Tryptophane was not detected because the meat was hydrolyzed with HCl. The composition of amino acids was almost the same as in the meat of other marine creatures.

As seen in Table 2, about 57 % of the total amount of nitrogen of abalone meat was monoamino nitrogen, while about 35 % was diamino nitrogen. The amount of monoamino nitrogen in abalone meat is much greater than that in squid, Atka mackerel or sea cucumber meat. For that reason the abalone meat may be delicious in taste. The amount of diamino acids was next to that of squid meat. From those results, it was supposed that abalone meat is not inferior to that of other marine creatures in nutrition.

2. Nitrogen distribution of hot water extractive of abalone meat

1) Experimental method

One hundred and fifty g of the minced abalone meat was extracted with 450 cc of water at 40°~50°C for one hour. Trichloroacetic acid was added into the extractive in order to precipitate the protein in the extractive. The precipitate obtained was filtered through a pulp layer and the filtrate was concentrated. The concentrated filtrate was hydrolyzed with 20 % HCl for 48 hours. The hydrolyzate was used for detection of the amino acids by paper chromatography and for the determination of nitrogen distribution by Van Slyke's method.

2) Results

The kinds of amino acids detected by the paper chromatography are shown in Fig. 5, while the nitrogen distribution determined by Van Slyke's method is shown in Table 3.

A comparison of the nitrogen distribution in the extractives from abalone with that from Atka mackerel²⁾, sea cucumber⁴⁾ and squid⁵⁾ is seen in Table 3.

As noted in Fig. 5, aspartic acid, glutamic acid, cystine, glycine, serine, alanine, leucine, lysine, valine, phenylalanine, tyrosine, and betaine are detected in the extractive. The amount of the nitrogen extracted by hot water in the abalone meat was one-tenth of that of Atka mackerel, and was less than that of squid meat. In the extractive of squid meat, the amount of diamino nitrogen was much greater than that of monoamino nitrogen, but in the extractive of abalone meat the amount of monoamino nitrogen was contrarily much more than that of diamino nitrogen; the former supplies about 57 % of the total amount

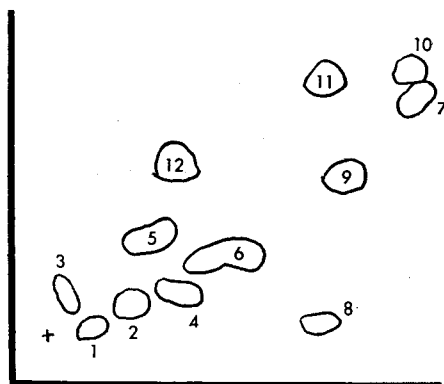

Fig. 5. Paper chromatograms of amino acids in the extractive from *H. discus hannai* meat

- | | |
|------------------|-------------------|
| 1. Aspartic acid | 7. Leucine |
| 2. Glutamic acid | 8. Lysine |
| 3. Cystine | 9. Valine |
| 4. Glycine | 10. Phenylalanine |
| 5. Serine | 11. Tyrosine |
| 6. Alanine | 12. Betaine |

Table 3. Nitrogen distribution in the extractive from *H. discus hannai* meat

Sample	Abalone		Atka mackerel	Sea cucumber	Squid
	g in 100 g of sample	% to total-N	% to total-N	% to total-N	% to total-N
Total-N extracted matter	0.530	100	100	100	100
20% HCl insoluble-N	0.017	3.16	0.79	4.48	—
20% HCl soluble-N	0.512	96.84	99.21	95.52	—
Amide-N	0.013	2.14	0.31	2.98	2.85
Humine-N	0.061	11.50	26.21	13.41	15.71
Basic total-N	0.178	33.60	32.49	37.35	40.04
Arginine-N	0.040	7.54	24.63	16.40	—
Histidine-N	—	—	—	20.09	—
Lysine-N	—	—	—	0.598	—
Cystine-N	—	—	1.57	0.448	2.44
Basic amino-N	0.043	8.13	7.13	11.94	—
Mono amino acid total-N	0.280	52.87	38.41	40.3	41.19
Mono amino acid amino-N	0.205	38.70	35.12	14.9	9.44
Total	0.549	103.17	98.03	98.52	99.79

of nitrogen. The amount of monoamino acids in monoamino nitrogen fraction is larger more than that in Atka mackerel and sea cucumber, and the ratio

$\left(\frac{\text{monoamino acid amino-N}}{\text{monoamino acid total-N}}\right)$ is about 76%. Shimidu⁶⁾ has said that the high ratio of monoamino acids to monoamino nitrogen may account for the delicious taste of of marine creatures' meat. The delicious taste of abalone meat can be explained by this high ratio.

III. HISTOLOGICAL OBSERVATIONS ON ABALONE MEAT

Before studying of fundamental properties of abalone meat, the authors have observed histologically the abalone meat, because the difference in the chemical properties of meat between fish and mollusca may be due to the difference in histological construction between them.

The differences of visceral construction and its histological observation, the construction of the shell and life history according to the kinds of the species of abalone have been studied by Ino⁷⁾ in detail.

1. Sample for histological observation

Flesh of abalones (*Haliotis discus hannai*) caught near Hakodate was removed from the shell and visceral mass was also taken out. The cross section of the large central muscle was cut as shown in Fig. 6-A.

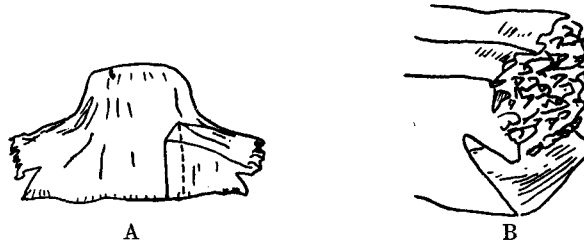

Fig. 6-A, B. Sample taken from the cross section

From the cross section, a rectangular block was cut off with a knife as shown by dotted line in Fig. 6-A. The end of the block enlarged as shown in Fig 6-B.

The block was soaked in Bouin's solution (saturated picric acid solution: formaline: acetic acid=75:25:5) for 2 hours. The fixed block was dehydrated by means of alcohol solution of 70%, 80%, 95% in order for each 30 minutes. Preparate finally was imbedded in paraffin. Thus treated block was sliced in 10μ (or 15μ) thickness with a microtome. Each slice was treated as usual, dyed with Delafields' haematoxyline staining method and enclosed in balsam to make a permanent preparate.

2. Microscopic observation

Permanent preparates taken as shown in Fig. 7 were observed. Microscopic observations were photographed as shown in Figs. 8 (A)~(D). For comparison of the microscopical structure of abalone meat with fish meat, microphotographs of "Suketodara" (Alaska pollack, *Theragra chalcogramma*) meat⁸⁾ are shown in Fig. 8 (E). From Figs. 8 (B)~(E), each model sketch was made as shown in Figs. 8 (B'), (C') and (E').

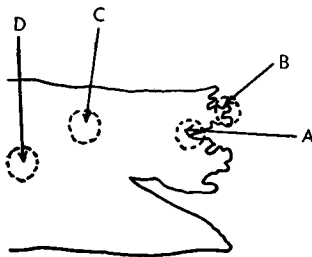

Fig. 7. Place from which preparates were taken

Figs. 8 (A) and (B) show a part of epithelial tissue. Fig. 8 (B') is a model sketch of Fig. 8 (B). As seen in Fig. 8 (B'), the epithelial tissue is different from tissue of the muscle. The inner part of muscle tissue is covered with connective tissue which protects the muscle tissue. Outside of the connective tissue, different shaped tissue are connected branch-like. In the openings between branch-shaped tissues there are many mucus cells.

Fig. 8 (C) and (D) show inner construction of the muscle. Fig. 8 (C') is a model sketch of Fig. 8 (C). Fig. 8 (C) and (D) are similar to the part of muscle in Fig. 8 (A) and (B). But the deeper the muscle meat, the more thick the muscle fibre is observed to become. In those parts shown in Fig. 8 (C) and (D), the connective tissue can not be observed, but the muscle fibres run horizontally and vertically in all directions. Those muscle fibres connect with epithelial tissue at the ends. In comparing abalone meat with "Suketodara" (*Theragra chalcogramma*) meat of which microscopical photographs are shown in Fig. 8 (E) and (E'), each muscle bundle of "Suketodara" is seen to consist of several muscle fibres which are bound to be twisting. Many muscle bundles are situated in parallel, and between each separate muscle bundle there is connective tissue. But the connective tissue of abalone is present only at the part of epithelial tissue. "Suketodara" arrangements of muscle bundles are different from those of abalone. Therefore the fish meat may be softer than the abalone meat.

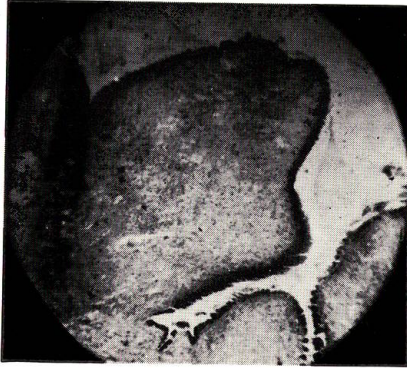

Fig. 8-A. Photograph (cross section) of A part of *H. discus hannai* meat



Fig. 8-B. Photograph (cross section) of B part



Fig. 8-C. Photograph (cross section) of C part

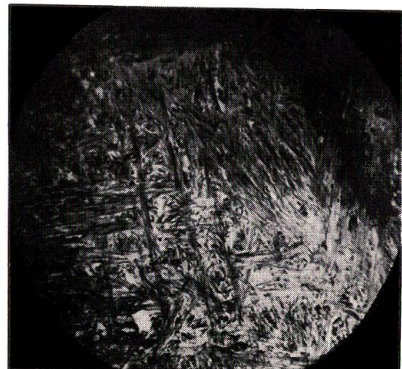

Fig. 8-D. Photograph (cross section) of D part

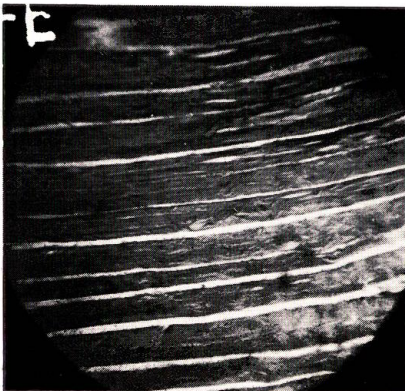

Fig. 8-E. Photograph (cross section) of "Suketodara" (*Theragra chalcogramma*) meat

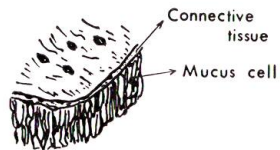

Fig. 8-B'. Model sketch of B part of *H. discus hannai* meat



Fig. 8-C'. Model sketch of C part of *H. discus hannai* meat

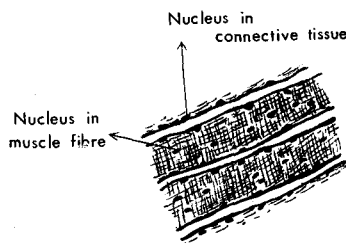

Fig. 8-E'. Model sketch of "Suketodara" (*Theragra chalcogramma*) meat

IV. CHEMICAL PROPERTIES OF ABALONE MEAT PROTEIN

In preparing dried or canned abalone, it is important to know the chemical properties of the protein of the raw material. There are few studies concerning the proteins of abalone meat^(1b). The authors have carried on a series of experiments on the protein of abalone.

1. Dissolution of abalone meat

It is important to know the solubility of the abalone meat by water, acid or alkaline solutions, because when abalone is used as the raw material of various products, especially for canned goods, the solubility influences the yield and the quality of the product. Here, the authors have undertaken to determine the solubility by various solutions.

(A) Dissolution by water

1) Experimental method and results

After the shell and visceral mass were removed, the abalone (*Haliotis discus hannai*) meat was cut fine. Dissolution was tested according to the procedure of Matsumoto⁹⁾ (Schemel 1).

To 30 g of the finely cut meat, 300 cc of dist. water was added and the solution was stirred for 30 minutes, then centrifuged (3,000 r. p. m. for 30 minutes). An upper transparent liquor was obtained. Five cc of the liquid was used for the estimation by Kjeldahl's method of the amount of dissolved nitrogen.

The amount of nitrogen dissolved out by water (E_1) was 20.9% of the total amount of nitrogen in the sample meat. The upper transparent liquid was dialyzed with dist. water for 7 days, and then the liquid was centrifuged (3,000 r.p.m. for 30 minutes). The amount of nitrogen in the centrifuged clear liquor (M_1) was 6.9% of the total amount of nitrogen. To the residue (R_2) 0.5 Mol

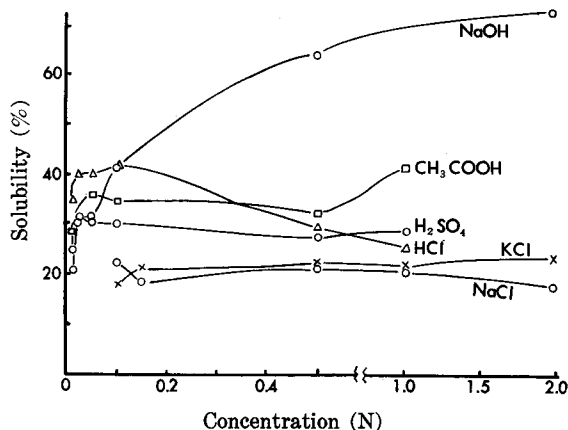

Fig. 9. Solubility of *H. discus hannai* meat by salts, acids and alkalis

The amount of nitrogen dissolved from abalone meat by water was about 22%, and that by 0.1 N NaCl was about 22.5%. These values were almost the same. As to the amounts of nitrogen dissolved by NaCl and KCl solutions, their solubilities are also almost the same. According to the change in the concentration of NaCl solutions, the solubility was irregular, while in KCl solutions, the higher the concentration of the solution, the greater the solubility was. But according to the difference of the concentrations of neutral salts there were no remarkable different effects upon the solubilities.

On the other hand, the solubility by NaOH solution is large, about 74%, and the lower the concentration, the smaller the degree of solubility is. Differently, the solubilities by various acids vary with the kind. For example, there is remarkable difference between hydrochloric acid and sulfuric acid. Okada *et al.*¹⁾ or Fujii²⁾ have explained this difference as follows: hydrochloric acid acts on proteins as a mono-basic acid, while sulfuric acid acts as a dibasic acid.

The solubility of the abalone meat in acetic acid showed high value (about 42%) in 1.0 N solution.

In general, differing from hydrochloric or sulfuric acid, the solubility by alkaline solution increased with the increase of the concentration.

The reason why such a difference exists may be explained as follows: in acid solution of high concentration the protein of the abalone meat coagulates; contrarily in alkaline solution the meat protein will be hydrolyzed.

On the basis of the above described observations, the abalone meat can be said to be dissolved by water or NaCl solution, when the meat is soaking in water or NaCl solution during the processing, but the solubility is smaller than that of

fish meat²⁾⁸⁾.

2. Isoelectric points of protein of the abalone meat

Abalone meat contains a few kinds of protein, therefore the solubility of the meat by various solvents is expected to be different.

Next, the authors undertook to determine the isoelectric points of proteins which are extracted from the meat by means of water or NaCl solution.

1) Experimental method

After the shell and visceral mass were removed, the abalone (*Haliotis discus hannai*) meat was cut finely. To 15 g of the finely cut meat, 250 cc of dist. water or 0.5 N NaCl solution were added; the solution was occasionally stirred, and left for 24 hours, then water-soluble protein or NaCl solution soluble protein were obtained by filtering with paper-pulp layer.

Each 10 cc portions of those water soluble protein or NaCl soluble protein solution were added to 40 cc portions of the buffer solutions having various pH values which were prepared from N/25 NaOH and N/25 HCl solutions, respectively. After the solutions had been left for 24 hours, the resultant precipitate was filtered. The pH value and viscosity of the filtrate were determined. The relative viscosity (η/η_0) was measured by Ostwald's viscosimeter in a thermostat of 13°C. The pH value of the protein solution which possesses the minimum relative viscosity, is considered as the isoelectric point of the protein. On the other hand, the total amount of nitrogen in the precipitated substance noted above was estimated, and the pH value at the maximum amount of nitrogen, was determined and regarded as the isoelectric point of the protein.

2) Results

The results obtained are shown in Figs. 10 and 11.

As seen in Figs. 10 and 11, the isoelectric point of water soluble protein of the abalone meat was 4.8~5.2, and that of NaCl solution soluble protein was 5.2. The reason why the isoelectric point has some range is the fact that the protein is not a single component, but consists of several components.

Comparing the isoelectric points which were determined by the viscosity method and those obtained by the method of the estimation of the total amount of nitrogen in the precipitated substance, the two isoelectric points were found to be in agreement as shown in Figs. 10 and 11.

Okada *et al.*¹⁰⁾ have stated that the isoelectric points of squid and fish ("Aji", carp and skipjack) meat are pH 4.8 and 5.5, respectively. The isoelectric point of the abalone meat resembles that of squid. Abalone and squid are both mollusca. The isoelectric points of the mollusca are situated pretty well to the acidic

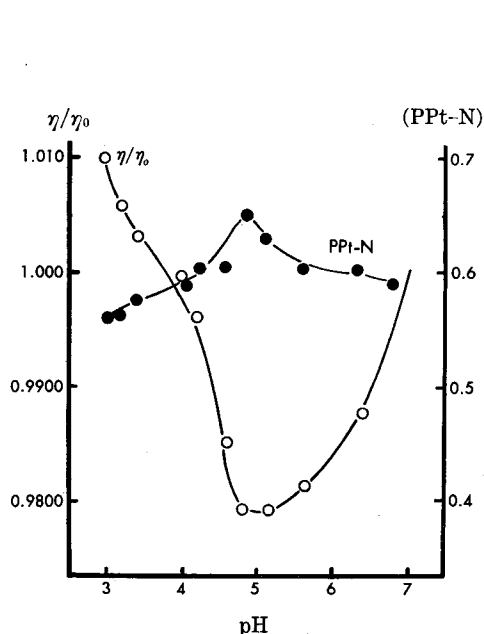

Fig. 10. Isoelectric point of water-soluble protein of *H. discus hannai* meat

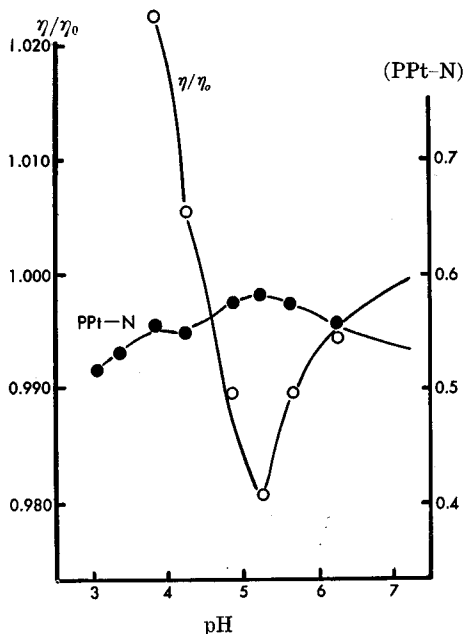

Fig. 11. Isoelectric point of 0.5 N NaCl solution soluble protein of *H. discus hannai* meat

side than those of fish meat. The reason why the isoelectric point of the mollusca is more acidic is not the difference of the constituents of protein (*e.g.* composition of the kinds of amino acid), but may be due to the fact that electro-chemical balance between acidic and basic amino acids is inclined to the acidic side¹¹⁾.

3. The phenomenon of flow birefringence of the extractive of the abalone meat

The phenomenon of flow birefringence (S.B.) in the extracted solution of fish meat has been observed by Okada and Tada¹²⁾. According to their report, in the extractive of fish meat by KCl solution (0.6 M) the pattern of flow birefringence was clearly shown, but no pattern of flow birefringence was shown in water extractive solution. Contrarily the pattern of flow birefringence was observed both in water soluble solution and in KCl soluble solution of mollusca meat.

Matsumoto¹³⁾ have studied the flow birefringence in the water extractive of squid. Tanikawa *et al.*¹⁴⁾ have also studied that in sea cucumber meat. They all have observed the pattern of flow birefringence in the water extractives.

Here, the authors would report their attempts to observe the flow birefringence in the solutions of water soluble, Weber's solution soluble and NaCl solution-soluble proteins by the same apparatus employed in studying the extracts of sea

cucumber meat (*Stichopus japonicus*)¹⁴⁾.

1) Experimental method

After the shell and visceral mass were removed, the abalone meat was cut finely. To 20 g of the sample meat, 200 cc of dist. water was added. After 15 minutes' stirring of the mixture, it was centrifuged (3,000 r.p.m. for 30 minutes). The flow birefringence of the upper clear liquor thus obtained was observed. The total amount of nitrogen in the same upper clear liquor was estimated, and the dissolved ratio (%) of the nitrogen relative to the total nitrogen in the raw meat was calculated. Biuret reaction, Molisch reaction and Diazo reaction were also applied to the same upper clear liquor.

To the residue of the 1st extraction, 200 cc of dist. water was added and the 2nd extraction was carried out. Intensity of birefringence and the total amount of nitrogen were also estimated for the 2nd extract. The extractions were continued as long as the flow birefringence could be distinguished, as shown in Scheme 2.

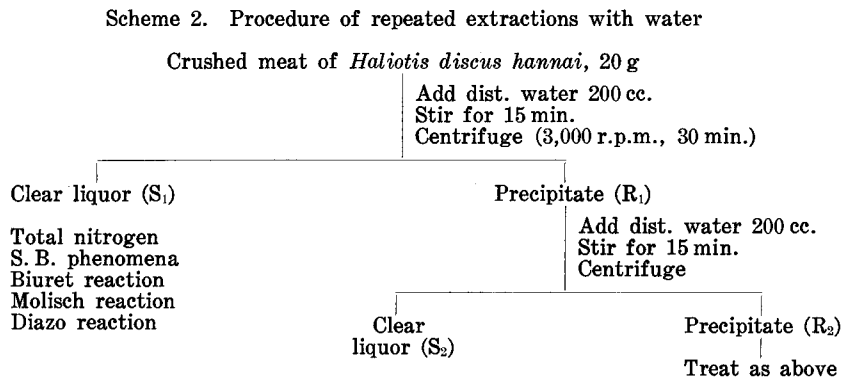

Extraction was also done by the use of Weber's solution (which consists of KCl, NaHCO₃ and Na₂CO₃ in the proportion of 0.6, 0.04 and 0.01 Mol, respectively) as well as by water.

2) Results

Results obtained are shown in Tables 4 and 5.

As seen in Table 4, no pattern of flow birefringence appeared from the 1st extraction to the 3rd extraction. From 4th to the 11th extraction, the pattern appeared; at last in the 12th extraction, the pattern disappeared. On the other hand, in the extraction of the meat by the use of Weber's solution, from the 1st to the 3rd extraction the pattern was observed, and from the 4th extraction the pattern disappeared. The pattern in the 2nd extraction was markedly apparent.

Table 4. Phenomena of dissolution of *H. discus hannai* meat during repeated extractions with water

Extraction No.	Extracted solution (cc)	Soluble nitrogen of extracted soln. (mg)	Soluble-N Total-N (%)	S. B.	Biuret react.	Molisch react.	Diazo react.	Appearance of sediment
S ₁	200	9.53	2.16	—	+	+	+	Kept in original form
S ₂	200	4.52	1.25	—	+	+	+	Softening of meat
S ₃	200	3.37	0.77	—	+	+	+	Ditto
S ₄	200	2.56	0.58	+	+	+	+	Further softening, D-layer piled on
S ₅	195	1.86	0.42	+	+	+	+	Ditto, upper layer of sediment flowed out by decantation
S ₆	195	1.38	0.31	+	+	+	+	Ditto
S ₇	200	1.63	0.37	+	+	+	+	Ditto
S ₈	200	1.05	0.24	+	+	+	+	Ditto
S ₉	200	1.05	0.24	+	+	+	+	Ditto, D-layer decreased in volume
S ₁₀	200	0.98	0.22	+	+	+	+	Ditto
S ₁₁	200	1.05	0.24	±	+	+	+	Decreased further
S ₁₂	200	0.93	0.21	—	+	+	+	

Table 5. Phenomena of dissolution of *H. discus hannai* meat during repeated extractions with Weber's solution

Extraction No.	Extracted solution (cc)	Soluble nitrogen of extracted soln. (mg)	Soluble-N Total-N (%)	S. B.	Appearance of sediment
S ₁	200	11.05	2.50	+	Softening of meat
S ₂	200	6.48	1.46	+	Ditto
S ₃	200	2.56	0.58	±	Ditto
S ₄	200	2.10	0.47	—	Ditto

As above noted, the extractions of abalone meat by the use of water or Weber's solution showed a pattern of flow birefringence.

In chemical studies on the proteins of sea cucumber meat reported by Tanikawa,¹⁴⁾ the amount of nitrogen dissolved out was proportional to the strength of the pattern of flow birefringence and there should exist an intimate relation between them.

But in the case of abalone meat, such fact could not be observed with 20 times volume of dist. water. The first extracted solution consists of three layers: A-layer which is an upper clear liquor, B-layer which is situated in the bottom of the centrifugal tube and contains white cloudy rod-like, thread-like or filament-

like sediment which is supposed to be stroma, C-layer which is situated above B-layer and contains white semi-transparent gruel-like substance. After the second extraction, a small amount of sediment is formed in the upper part of C-layer, indicating liquidity, and if the tube is inclined, the liquid layer flows out in company with A-layer. Matsumoto¹⁵⁾ has called it "D-layer" (Fig. 12).

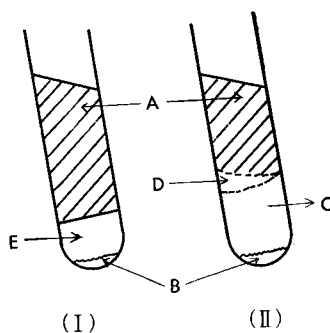

Fig. 12. Appearance of centrifuged sediment of aqueous extracted solution
 (I) The first extract
 (II) The second and the following extracts
 A-phase Supernatant
 B-phase White coarse residue
 C-phase Translucent paste
 D-phase Fluid suspension
 E-phase White compact paste

In the case of extracting of the abalone meat with water, when the D-layer appeared, the pattern of flow birefringence has been observed; when the D-layer disappeared, no pattern was observed. Those phenomena are similar to those observed in the case of extraction of sea cucumber meat¹⁴⁾.

Here, the 5th extractive solution showing markedly apparent pattenen of flow birefringence, was heated at various temperatures for 10 minutes or filtered through filter paper, and the phenomena of the flow birefringence was observed. The results obtained are recorded in Table 6.

As seen in Table 6, when the 5th extraction solution was heated above 65°C, the pattern of flow birefringence became unobservable.

From the observations, it is evident that the phenomenon of the flow birefringence in the water-extractives of abalone meat does not occur in the first extraction, but several extractions later. The phenomenon does not appear after the filtration of the extractives and furthermore also the phenomenon disappears after heating the extractive above 65°C.

Table 6. Flow birefringence after heating at various temperatures or after filtration of the 5th water-extracted solution of *H. discuss hannai* meat

Temp. (°C)	S. B.
35	+
45	+
65	±
75	—
After filtration	—

As the pattern of flow birefringence had been distinguished after filtration, the molecular shape of the substance in the extractive showing the pattern was assumed to be large.

The similar phenomenon was observed by Tanikawa¹⁴⁾ in studying sea cucumber meat. In the case of the sea cucumber meat, Tanikawa has considered that the muscle fibre which consists mainly of collagen fibre will be deformed mechanically by the extraction with water and that fibre flakes which form the pattern of flow birefringence will disperse in the extractive solution.

As histologically observed, the muscle fibers of the abalone meat are fine and arranged like net-work. Such histological properties of the abalone meat resemble those of sea cucumber meat. So the appearance of the pattern of flow birefringence in the extraction of abalone meat is considered to be due to the mechanical deformation of muscle fibre, by which the fibre flakes will be dispersed in the extractive showing the pattern of flow birefringence.

4. Dehydration and coagulation of the abalone meat by heating

It is important to know about the phenomena of coagulation and of dehydration of abalone meat by heating in order to decide the heating conditions during the processing of the canned goods.

Here, the authors discuss their attempt to estimate the ratios of absorption or dehydration of water of the abalone meat heated in water at various temperatures, and heat coagulation of proteins which were extracted by water or NaCl solution.

(A) Absorption or dehydration of water

When fish meat is soaked in water at comparatively low temperatures, the meat absorbs water, but when it is heated in hot water dehydration occurs.

The authors undertook to find out whether similar phenomena occur or not, when the abalone meat is soaked in water at various temperatures.

1) Experimental method

From abalone (*Haliotis discus hannai*) caught near Hakodate, Hokkaido, the shell and visceral mass were removed. The central muscle meat was cut to prepare blocks of about 2 cm³ in size (4~5 g). The blocks were weighed as W_0 . Some blocks were put into a beaker containing 50 cc of water. The temperature of the water was raised slowly by heating to each pre-determined definite temperature from 20° to 90°C. Above 100°C, each beaker in which one individual block each was placed were heated to various temperatures in a retort. After the blocks were heated at each definite temperature for 20 minutes, they were taken from the beaker, and cooled. The water attached to the surface of the blocks was wiped off with filter paper. The blocks were then weighed as W . The difference between the weight of the block after the before the immersing in heated water was obtained and the ratio of the difference to the original weight was calculated $\left(\frac{W-W_0}{A} \times 100\right)$.

If the original weight (W_0) is less than the weight (W) of a block after the soaking, the ratio shows plus; this is the ratio of absorption of water. But if the original weight (W_0) is larger than the weight (W) of block after the soaking, the ratio shows minus; this is ratio of dehydration.

2) Experimental results

Results obtained are shown in Fig. 13.

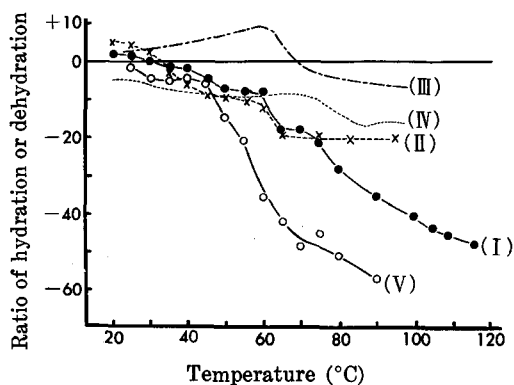

Fig. 13. Hydrating and dehydrating curves of *H. discus hannai* meat and other fish meat

I Abalone, II Atka mackerel, III Salmon
IV Loach, V Sea cucumber

In Fig. 13, curve I shows the curve of abalone meat, curve II shows that of Atka mackerel meat²⁾, curves III and IV show those of salmon¹⁶⁾ and loach¹⁷⁾, and curve V shows that of sea cucumber meat¹⁴⁾.

As seen in Fig. 13, with the boundary at the temperature of 30°C, the meat absorbed water below 30°C, while it lost water at above 30°C. In the part of the curve showing dehydration, there are observed steep slopes between 40°~55°C, and between 60°~70°C. Above 75°C, the dehydration became rapid. At this point, all the proteins in the meat is considered to be completely coagulated. On the basis of those observations, there seem to be two kinds of proteins in the abalone meat. One of them corresponds to myosin whilst the other corresponds to myogen.

The fact that the ratio of dehydrating of abalone meat decreased largely at higher temperatures resembles that of sea cucumber meat. Accordingly it is assumed that the muscle fibre of abalone meat takes the form of a net-work construction like that of sea cucumber meat.

(B) Heat coagulation

When fish meat is heated in water, the proteins in the meat are coagulated at a certain temperature according to the kind. The authors have tried to determine the temperatures at which proteins coagulate in the present material.

1) Experimental method

Abalone (*Haliotis discus hannai*) meat was obtained by removal from the shell and cutting away the visceral mass. The abalone meat was cut fine. To 100 g of the finely cut meat 300 cc of dist. water was added. The mixture was left for one hour with occasional stirring. After having been left, the mixture was filtered. Ten cc portions of the filtrate (water soluble protein) were poured separately into test tubes. Those test tubes were heated separately at each pre-determined temperature from 25°C to 90°C for 10 minutes. After the heating, the test tubes were cooled rapidly, and the solution was filtered. The total amount of nitrogen in 5 cc of the filtrate was estimated by Kjeldahl's method. The difference in the amount between that in a definite volume (5 cc) of the filtrate (non-coagulable protein) and in that of the original water-soluble protein solution was considered to be the coagulable protein.

Similarly, the amounts of protein in the meat coagulable by heating in 0.5 N NaCl solution at various temperatures were estimated.

2) Experimental results

Results obtained are shown in Fig. 14.

In Fig. 14, curves I and II show the heat coagulation of the extractives of abalone meat by water or 0.5 N NaCl solution, respectively, curve III shows that of sea cucumber¹⁴⁾ by 0.5 N NaCl solution, curves IV and V show those of Atka mackerel²⁾ by water or by 0.5 N NaCl solution and curve VI shows that of squid meat¹⁸⁾ by water, respectively.

As seen in Fig. 15, the heat coagulation of water-soluble protein was completed

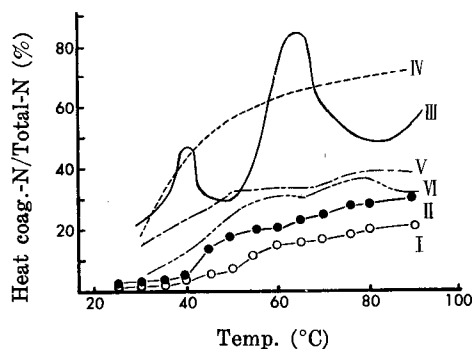

Fig. 14. Heat coagulation curves of *H. discus hannai* meat and other fish meat

- I Abalone (in dist. water)
- II Abalone (in 0.5 N NaCl Soln.)
- III Sea cucumber (in 0.5 N NaCl Soln.)
- IV Atka mackerel (in dist. water)
- V Atka mackerel (in 0.5 N NaCl Soln.)
- VI Squid (in dist. water)

within two temperature ranges from 45°C to 50°C and from 60°C to 65°C. The slope from 40°C to 45°C was not remarkable, while that from 55°C to 60°C was pretty remarkable. The curve showing the water-soluble protein ascended gradually from about 40°C and reached 60°~66°C. The main component of the coagulable protein in this case is considered to be myogen.

On the other hand, the heat coagulation of 0.5 N NaCl solution-soluble protein starts from 35°C, continues gradually to 40°C, then continues rapidly from 40°C to 55°C and becomes slow from 60°C. The coagulation is again caused to occur pretty largely from 70°C to 80°C. That is to say, there are observed in this curve two steps indicating the presence of two kinds of proteins.

One of the proteins which is coagulated at the lower temperature (40°~55°C) is actually myosin, while the other at higher temperature (60°~70°C) is considered to be myosin. The presence of two kinds of proteins was also observed in the dehydrating curve obtained as described above.

In other curves (curves III, IV, V and VI), the steps corresponded obviously to two kinds of proteins.

5. Swelling of the abalone meat.

To study the swelling of proteins is considered to be one of the important methods to find out about the hydration of the proteins, because the swelling of protein is considered to be one of the phenomena of lyotropic hydration.

The authors have examined the phenomena of swelling of the abalone meat

immersed in various salt solutions and the relations among the degree of swelling, the kind of salts and the pH value of the immersion solution.

1) Experimental method

After the shell and visceral mass were removed, the abalone (*Haliotis discus hannai*) meat was cut into small cubes (about 2g). After the blocks were weighed, they were separately put into beakers each containing 50 cc of various salt solutions having various concentrations or having various pH values. After the beakers had been left at room temperature (20°~25°C) for 24 hours, each block was taken out from the beaker. The water attached to the surface of the blocks was wiped off with filter paper. Each block was then weighed. The ratio of the weight of the block after the immersion (W) to that before the immersion (W_0) was calculated as the degree of swelling (S) of the sample meat ($S=W/W_0$).

Salt solutions employed were NaCl, KCl, MgCl₂, CaCl₂, KI, K₂SO₄, KCNS, NaNO₃, KNO₃, CH₃COONa·3H₂O, NH₄Cl, Na₂CO₃, Na₂SO₄, Na₃PO₄·3H₂O, and C₃H₄OH (COONa)₃ solution of 0.1, 0.2, 0.4, 0.6, 0.8, 1.0 and 2.0 Mol. As contrast, dist. water was also employed.

The immersion solutions having various pH values were prepared by varying the proportion of the mixture of N/10 HCl and N/10 NaOH covering the range of pH 2 to 8.

2) Results

Results obtained are shown in Figs. 15~18.

The degree of swelling of the abalone block meat in various concentrations of solutions containing chlorides are shown in Fig. 15. Those in solutions containing sodium salts are shown in Fig. 16. Those in solutions containing potassium salts are shown in Fig. 17. Those in solutions having various pH values are shown in Fig. 18.

As seen in Figs. 15~17, the degrees of swelling of the abalone meat in the

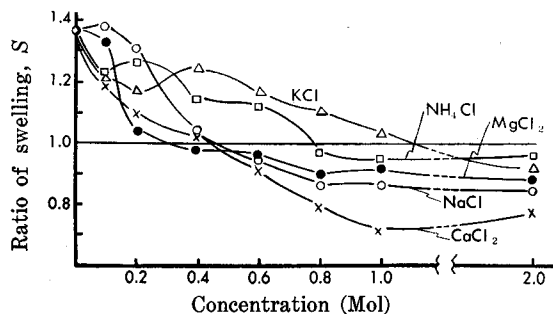

Fig. 15. Degree of swelling of *H. discus hannai* meat in various concentration of solutions containing chlorides

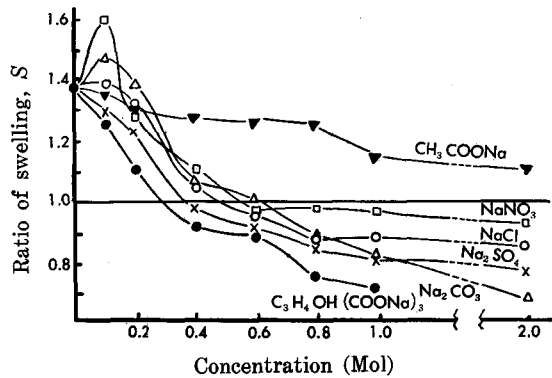

Fig. 16. Degree of swelling of *H. discus hannai* meat in various concentrations of solutions containing sodium salts

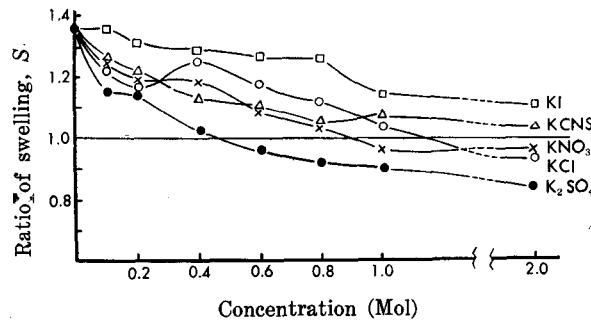

Fig. 17. Degree of swelling of *H. discus hannai* meat in various concentrations of solutions containing potassium salts

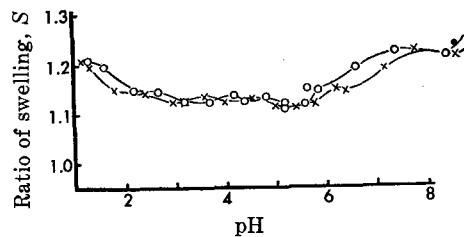

Fig. 18. Degree of swelling of *H. discus hannai* meat in solutions of various pH values
 ×....pH of adjusted soln.; O....pH after 24 hrs.

solutions of salts are different according to the concentrations of the solutions. Similarly, those in solutions having various pH values are different according to the pH value.

The observations of the degrees of swelling in the salt solutions are summarized as follows:

(1) In 0.2~2.0 Mol solutions of various salts, the degrees decreased with increase of molecular weight of the salts.

(2) As to monovalent salts, there is a maximum point of the degree of swelling between 0.1 and 0.4 Mol concentrationn.

(3) As to divalent or tri-valent salts, the maximum points are not noticeable.

(4) The degrees of swelling in salt solutions having Cl^- , are smaller than those having Na^+ or K^+ .

(5) Between pH 5.0 and 5.4 (the isoelectric range of the abalone meat proteins), the degrees of swelling in solutions having various pH values are the minimum. Generally speaking, the degrees of swelling of the abalone meat are less than those of fish meats such as Alaska pollack¹⁹⁾ or Atka mackerel²⁾. This is due to the characteristics of the abalone meat muscle which have been clarified by the histological studies showing the net-work construction of muscle fibres.

This net-work construction of the muscle tissue prevents penetration of water into muscle tissue resulting in diffeulty of hydration.

From another point of view, the swelling of high molecular substances such as protein is said to be a dissoluting process, and is regarded as a kind of solvation (hydration). Therefore, the hydration is influenced by ionic valency which has intimate relation with the pH values of the solution. For this reason, at the isoelectric point the binding strength between protein molecular and water molecular structures becomes the minimum, and the degree of swelling will show the minimum.

6. Hydration of the abalone meat

In order to gain further knowledge on the hydration of the abalone meat, the water-content (g)—relative vapour pressure (p/p_0) curve in the fresh raw meat was determined.

Similarly the curves in the canned abalone meat were determined, and the relation between hydration and cooking was ascertained.

A) Fresh raw abalone meat

1) Experimental method

The relation between water-content (g of water per g of the dried matter), " g " and relative vapour pressure " (p/p_0) " in fresh abalone meat (water-content 77.1%, volatile basic nitrogen 2.01 mg%) was determined at 20°C by vapour tension method²⁰⁾.

2) Results

The results obtained from the fresh raw abalone meat are shown as Fig. 19.

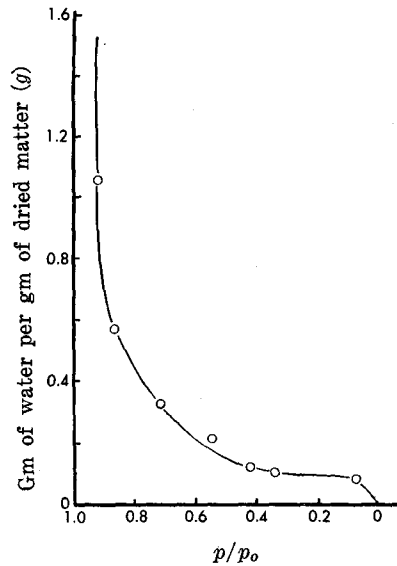

Fig. 19. " $g-p/p_0$ " curve of fresh raw *H. discus hannai* meat

According to the results obtained by many investigators^{20b), 21)}, in the estimation of the bound water by vapour tension method, water below the range of 0.5 to 0.6 water-activity (p/p_0) has been regarded as molecular theoretical bound water. In the present experiment, at the value of 0.5 of water-activity the amount of water content " g " (g of water per g of dried matter) was 0.15. This value was compared with corresponding values of 12 other kinds of marine creature meats^{20c, d)}; they are almost the same. This will show that the properties of abalone meat protein are not remarkably different from those of other marine creatures, even though the amount of the protein differs from that of others.

(B) Canned abalone meat

Fresh raw abalone meat and unfresh raw abalone meat samples which were left in a thermostat for some time, were submitted to the processing. The two raw materials were cooked at 3 lbs pressure for 10 minutes, and then were filled separately into cans. The cans were processed at 10 lbs pressure for 80 minutes. After two months' storing of the cans, the meats were taken out and used for the estimation of " $g-p/p_0$ " curve. The freshness of the original raw material was reflected by the values of 7.0 and 21.8 mg%, respectively as the amount of volatile basic nitrogen.

The amount of volatile basic nitrogen of the two meat samples after the opening of the cans was 10.1 and 18.4 mg%.

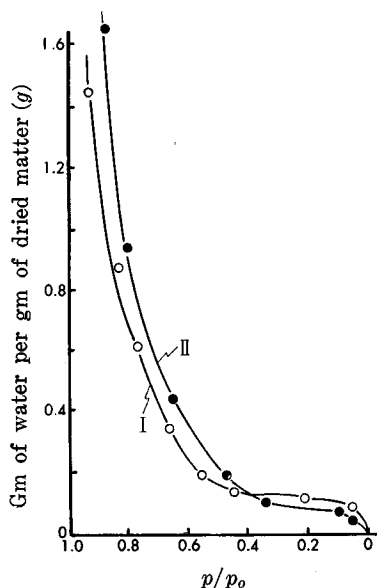

Fig. 20. " $g-p/p_0$ " curves of canned abalone meat
 I Fresh raw material (V. B.-N, 7 mg%)
 II Unfresh material (V. B.-N, 21.8 mg%)

2) Results

The results obtained are shown in Fig. 20.

As seen in Fig. 20, the hydrating affinity of water in canned abalone meat has no remarkable difference, in comparison with that of fresh raw abalone meat.

This will be a factor in the canning of abalone meat, of which the appearance and elasticity are like those of raw abalone meat. The fact that the hydrating affinity of water is almost the same as that of raw abalone meat, may be explained from the fact of the less amounts of heat coagulable protein nitrogen, water soluble protein nitrogen, and NaCl solution-soluble protein nitrogen than those of other fish meat.

As to the freshness of the abalone meat, the curve showing the hydrating affinity of water for the canned abalone meat which was processed from unfresh raw abalone meat is situated lower than that for the canned meat processed from fresh raw abalone meat. That is to say, the amount of bound water in the former is less than that in the latter. The result obtained as above suggests that the hydrating affinity of water in abalone meat decreases with the denaturation of the meat protein during storing or processing.

Literature cited

- 1 a) Cited from Oya, T. *et al.* (1934). "Nantaidobutzu-no-Kagaku" (Chemistry of Mollusca). 208 p. Tokyo; Koseikaku-Koseisha.
- b) Takahashi, E. (1921). *Jour. Chem. Soc. Japan* 42, 537 (in Japanese).
- 2) Fujii, Y. (1954). *Bull. Fac. Fish. Hokkaido Univ.* 5 (3), 253 (in Japanese).
- 3) Igarashi, H. *et al.* (1953). "Hoksuishi-geppo" (Monthly Report of Hokkaido Fisheries Exp. St.) 10 (3), 36 (in Japanese).
- 4) Tanikawa, E. *et al.* (1955). *Bull. Fac. Fish. Hokkaido Univ.*, 6 (1), 37.
- 5) Yoshimura, K. *et al.* (1953). *Ibid.* 3 (3), 205 (in Japanese).
- 6) Shimidu, W. *et al.* (1953). *Bull. Jap. Soc. Sci. Fish.* 19 (8), 871 (in Japanese).
- 7) Ino, T. (1953). "Awabi" (Japanese Abalone). Tokyo; Tokai-shobo.
- 8) Tanikawa, E. *et al.* (1960). *Bull. Fac. Fish. Hokkaido Univ.* 11 (3), 162.
- 9) Cited from Migita, M. (1953). *Bull. Jap. Soc. Sci. Fish.* 18 (10), 116 (in Japanese).
- 10) Okada, M. *et al.* (1953). *Ibid.* 19 (3), 178 (in Japanese).
- 11) Migita, M. & Tanikawa, E. (1958). "Ika-no-Kagaku-to-Kako" (Chemistry and Technology of Squid) 34 p. Hakodate; Hokkai Suisan Shinbun-sha.
- 12) Okada, M. *et al.* (1954). *Bull. Jap. Soc. Sci. Fish.* 20 (3), 224 (in Japanese).
- 13) Matsumoto, J. Jr. (1957). *Ibid.* 23 (1), 47.
- 14) Tanikawa, E. (1955). *Mem. Fac. Fish. Hokkaido Univ.* 5 (1), 1.
- 15) Matsumoto, J. Jr. (1958). *Bull. Tokai Regional Fish. Res. Lab.* (20), 65.
- 16) Shimidu, W. (1943). *Bull. Jap. Soc. Sci. Fish.* 12 (3), 103 (in Japanese).
- 17) Shimidu, W. *et al.* (1951). *Ibid.* 17 (5), 18 (in Japanese).
- 18) Takagi, M. (1950). *Bull. Fac. Fish. Hokkaido Univ.* 1 (1), 23 (in Japanese).
- 19) Tanikawa, E. *et al.* (1961). *Ibid.* 11 (4), 203.
- 20 a) Akiba, M. (1951). *Ibid.* 1 (3-4), 156.
- b) ————— (1951). *Ibid.* 2 (3), 176.
- c) ————— (1952). *Ibid.* 2 (4), 239.
- d) ————— (1955). *Bull. Jap. Soc. Sci. Fish.* 20 (10), 937 (in Japanese).
- 21) Higashi, K. *et al.* (1948). "Kagaku-no-Kenkyu" (Chemical Researches) 1. Biochemistry, 23 (in Japanese).