



Title	DEVICES OF SIMPLE PLANKTON APPARATUS II
Author(s)	MOTODA, Sigeru; 元田, 茂
Citation	北海道大學水産學部研究彙報, 14(3), 152-162
Issue Date	1963-11
Doc URL	<a href="https://hdl.handle.net/2115/23187">https://hdl.handle.net/2115/23187</a>
Type	departmental bulletin paper
File Information	14(3)_P152-162.pdf



## DEVICES OF SIMPLE PLANKTON APPARATUS II

Sigeru MOTODA

*Faculty of Fisheries, Hokkaido University, Hakodate, Hokkaido*

Since twenty-two devices of simple plankton apparatus were reported (Motoda 1959), some of them, for instance, high-speed underway samplers, sample filtering apparatus, etc., have been practically used, while others have been felt to need some improvement or even the introduction of an entirely new idea. This paper presents five simple plankton gear and laboratory apparatus, all of which were actually produced, and all tested with the exception of one.

### I. Double release and hinged double vertical square net

(Figs. 1, 2, Pl. I, Figs. 1, 2)

The nets are designed for the use of vertical haul, dividing the range of samplings into two zones by a single haul. The dimension of 40 cm×40 cm in

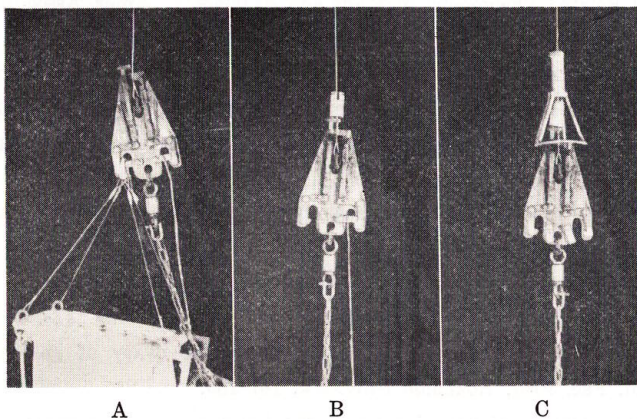

Fig. 1. Double release mechanism

- A. Before messengers are lowered
- B. After first messenger was lowered
- C. After second messenger was lowered

mouth frame of this prototype is rather small, and it may be necessary to enlarge this for practical uses. Two sets of similar square nets are hinged together at their projected arms, and when hauling one net is open, and the other net is closed (Fig. 2, A-C, Pl. I, Fig. 2); finally after the striking of the second messenger (Pl. I, Fig. 1, Ba, C) both two nets are closed (Fig. 2, D, Pl. I, Fig. 2, E). In a performance test made on the "Oshoro Maru" near the western entrance

of the Tsugaru Straits on May 9, 1963, the time required for obtaining samplings from 500-300 m and 300-150 m levels in a single haul was only 25 minutes. Rough counting of the number of animals in this sampling suggests that there is an apparent difference of population between the two samples (Table 1); accidental infiltration of samples from other zone seems to be negligible.

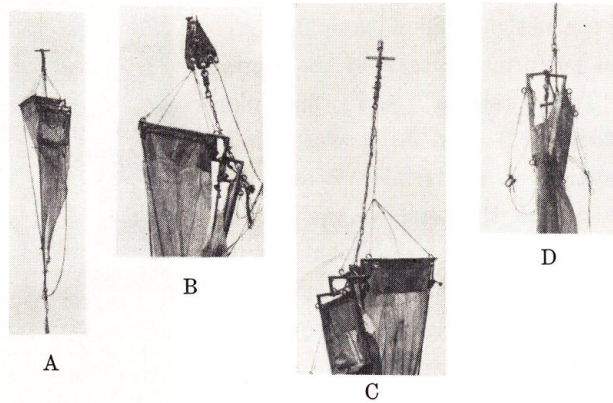

Fig. 2. Hinged double vertical square net

- A, B. First net is open and second net is closed.  
 C. First net is closed and second net is open.  
 D. Both nets are closed.

Table 1. Number of animals caught by divided haul with hinged double square net (Number of animals/100 m haul)

Sampling zone	150-300 m	300-500 m
<i>Calanus cristatus</i> (immature)	4	16
<i>Calanus plumchrus</i> (immature)	6	1
<i>Eucalanus</i>	1	0
<i>Euchaeta</i>	5	0
Small-sized copepods	230	1670
<i>Euphausia</i> (immature)	4	4
<i>Parathemisto</i>	45	4
<i>Conchoecia</i>	51	0
<i>Sagitta elegans</i>	13 (20-32 mm)	16 (10-14 mm)
<i>Aglantha digitale</i>	14	2
Siphonophores	3	0

## II. Triple release and multiple collapsible vertical net

(Figs. 4-6, Pl. II, Figs. 1-3)

The purpose of this net is for collecting deep water macroplankton by fast haul, by dividing the water into four zones and taking samples from each in a single vertical haul. It is not advisable to use the net in shallow sampling.

After several performance tests of the original models of "Triple release" and "Multiple purse net" (Motoda 1962) (Fig. 3), it was found that a certain portion of the triple release can be cut away to reduce the total weight of the mechanism as well as to reduce the resistance of the mechanism against the flow of water. It was also found that the purse nets frequently were not properly closed, some parts of the mouth remaining open. The second model of the triple release (Fig. 4, Pl. II, Figs. 1, 2), which was constructed principally under similar design to that of the original model, has always proved



Fig. 3. Original model of triple release mechanism and multiple purse net (Motoda 1962)

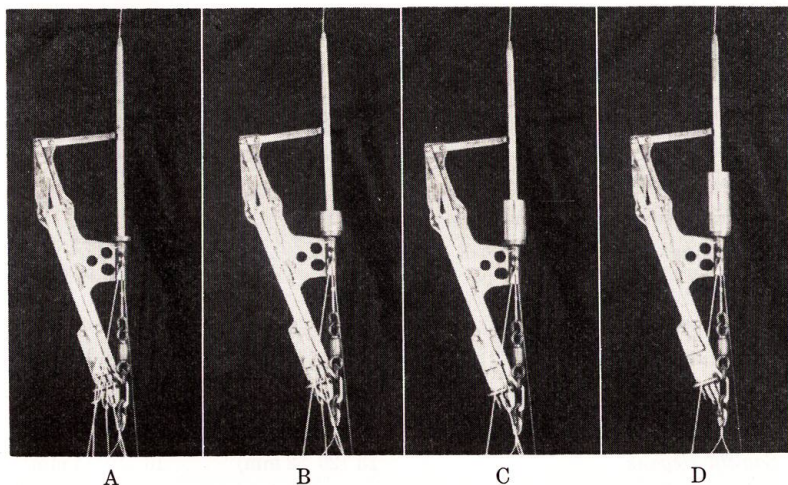

Fig. 4. Improved model of triple release mechanism

- A. Before striking of messengers.
- B. First messenger was lowered; first line was released.
- C. Second messenger was lowered; second line was released.
- D. Third messenger was lowered; third line was released.

to function correctly.

As for the net a completely different idea was employed in the second model. A conical net, made of coarse filtering cloth, 0.47 mm mesh (GG 40 bolting silk), is connected to a cylindrical cod end of the same mesh (Fig. 5, Pl. II, Figs. 2, 3). By lowering three messenger weights successively the cylindrical cod end which is held in an iron cage (Fig. 5, Pl. II, Fig. 3) can be successively closed at three points. Pushed by a set of two sliding weights of total weight 5 kg, the cylindrical cod end closes at that point, no longer allowing plankton animals to pass through. The net for such a closing system should have perfect filtering efficiency. All materials entering the mouth of the net must flow quickly down toward the lower portion of the cylindrical cod end before the respective point of the cylindrical cod end is closed. Therefore, fine mesh cloth cannot be employed for such a type of net. The mouth ring of the experimental model is 70 cm in diameter, but this could be enlarged. This model was taken on the cruise of the "Ryofu Maru" in June 1963, but the thick wire cable was unavailable, and consequently the performance test at sea has not yet been accomplished.

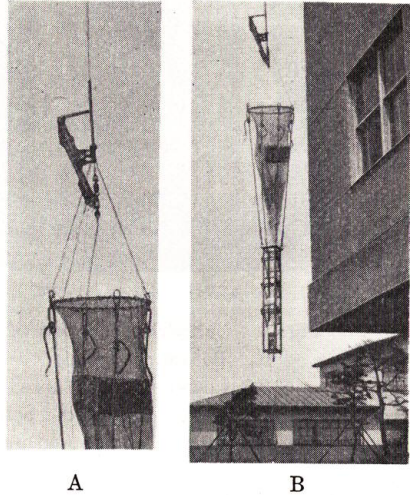

Fig. 5. Multiple collapsible vertical net hung from triple release  
 A. Triple release mechanism and upper portion of the net  
 B. Whole assembly of triple release mechanism and multiple collapsible net

### III. Horizontal square net fixed on triangular frame

(Fig. 7, Pl. III, Fig. 1, Pl. IV, Figs. 1, 2)

In sampling zooplankton at great depths vertical hauls with a closing net usually do not yield sufficient samples for qualitative as well as quantitative studies, because plankton animals are usually very sparsely distributed at those depths. It is therefore advisable to employ horizontal or oblique hauls, using several nets of considerable size simultaneously, if the ship is fitted for such work. There have been various types of opening-closing nets and double release mechanisms for the use of horizontal or oblique hauls through desired levels of water. Some gear seem to act very reliably, but their construction is usually rather complicated;

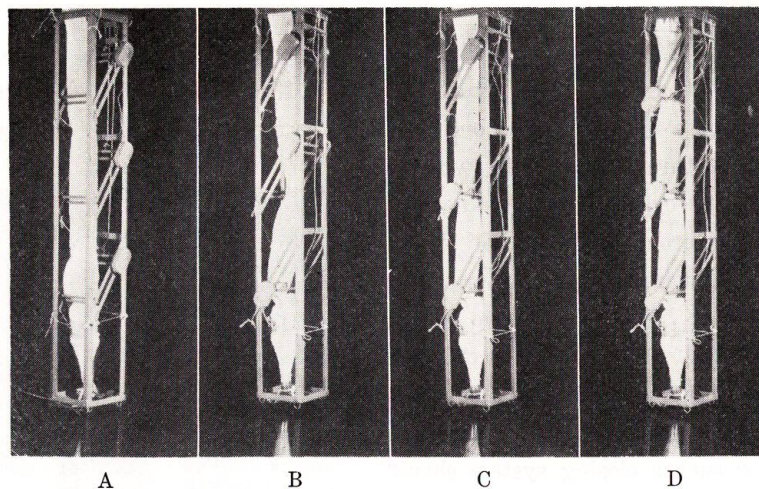

Fig. 6. Cylindrical cod end of multiple collapsible net held in iron cage

- A. Before collapsing
- B. Lower point collapsed.
- C. Lower and middle points collapsed.
- D. Lower, middle and upper points collapsed.

others have limitation of size of mouth opening. Presently the Clarke-Bumpus quantitative sampler (Clarke and Bumpus 1950, Paquette and Frolander 1957, Paquette *et al.* 1961) is widely used in the United States and Australia, and the quantitative multiple opening-and-closing plankton sampler (Bé *et al.* 1959, Bé 1962) has come to be employed also.

Since it was found that the "Simple net having sliding mouth ring" (Motoda 1959, p. 78) was not effective in avoiding the infiltration of unwanted materials during the retrieval of the net, it was hoped that the net could be closed after a horizontal haul by some simple convenient method. Complicated mechanisms rigged with a number of wires and ropes should be avoided. The principal features of a model of a horizontal closing net presented here are as follows: (1) It eliminates infiltration of unwanted materials during lowering and raising; (2) The action of the closing mechanism is reliable; (3) It reduces the number of ropes and wires to a minimum to avoid entanglement; (4) It enables attachment of several nets to a single wire cable; (5) The mouth opening is sufficiently large for practical purposes; (6) It is equipped with a clinometer to register the angle of the wire cable underwater; (7) It can be equipped with a flow-meter at the mouth frame for quantitative sampling; and finally (but rather important) (8) It should be simple and inexpensive to construct.

The square mouth frame measuring 50 cm×50 cm in the experimental model

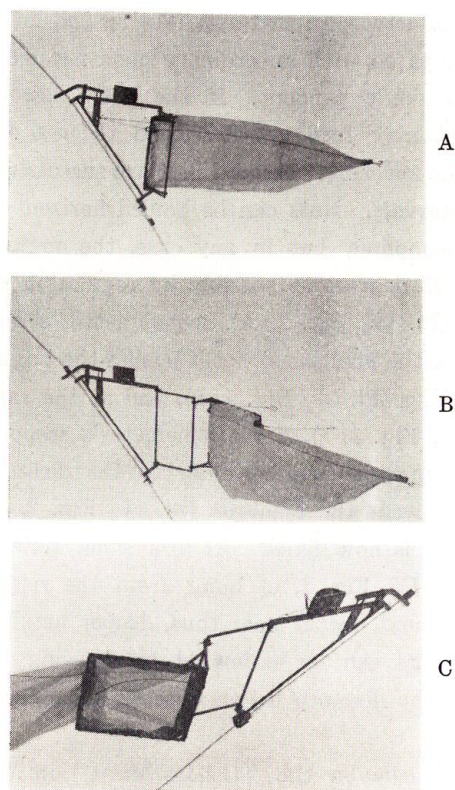

Fig. 7. Horizontal square net fixed on triangular frame

- A. Horizontal towing with open net.  
 B, C. Messenger was lowered; the net was closed.

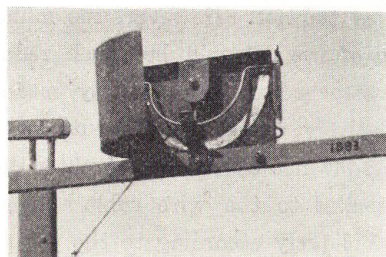

Fig. 8. Wire-clinometer attached to triangular frame

(Pl. III, Fig. 1, f, Pl. IV, Fig. 1, i) is allowed to rotate at the axis of the rotating arms (Pl. III, Fig. 1, g, Pl. IV, Fig. 1, m), and again at the central axial rod (Pl. III, Fig. 1, e, Pl. IV, Fig. 1, c). The mouth frame is supported in a correct position by being pulled by two bridles (Pl. III, Fig. 1, b, Pl. IV, Fig. 1, h) of which the ends are hung on a release mechanism on the triangular frame. The upper and lower conjunctions between the axis of the rotating arms (Pl. III, Fig. 1, g, Pl. IV, Fig. 1, m) and the short arms (Pl. III, Fig. 1, d, Pl. IV, Fig. 1, n) of the mouth frame should be

loosely constructed, otherwise it is difficult to attach two bridles to the release mechanism. There is a clinometer box (Fig. 8, Pl. III, Fig. 2, Pl. IV, Fig. 1, g) on the upper side of the triangular frame. A pendulum weight in the clinometer hangs freely, and can be fixed with a semicircular stopping bar when its supporting string (Pl. IV, Fig. 1, f) is released. The triangular frame is attached to the wire cable at the upper and lower ends of the oblique side of the frame. It rotates freely on the wire clip (Pl. III, Fig. 1, h, Fig. 4, Pl. IV, Fig. 1, d) which is tightly fixed to the wire cable.

While the ship is proceeding at a slow speed, or is drifting in a moderate wind, the first (deepest) net is lowered by paying out the wire cable. Because of simplicity of construction no closing mechanism is adopted when in the lowering position; the mouth of the net is open, so that a certain amount of plankton will

enter the net. However, the infiltration of unwanted materials during the lowering of the net will be much reduced compared with an ordinary open net which is attached to the wire by means of a single pendent. If the net is lowered relatively quickly, the mouth of the net may face upwards, and the net may possibly not collect any plankton during the lowering. Several nets are successively attached to the wire cable at desired intervals. Nets can be hauled horizontally or obliquely according to the purpose of sampling, but in any case, the angle of the wire cable should be kept as near to 45 degrees as possible by regulating the speed of the ship. When the sampling (Pl. IV, Fig. 2, A) is completed, a messenger weight is slid down. As it reaches the shallowest net it pushes the trigger on the triangular frame and frees the bridles (Pl. IV, Fig. 1, h), and at the same time, frees the supporting string (Pl. IV, Fig. 1, f) of the clinometer's stopping bar. The mouth frame is released and assumes an angle similar to the direction of the flow of the water; it no longer collects the plankton (Pl. IV, Fig. 2, B), and the pendulum weight of the clinometer is now fixed. At the same time, a messenger weight (Pl. III, Fig. 1, i, Pl. IV, Fig. 1, e) hung from the release mechanism is allowed to slide down to the next deeper net; thus, deeper nets are successively closed. The depths of samplings can be estimated by drawing the curve of the wire cable on the basis of the distance between nets and angle of the wire at the position of the nets.

A preliminary performance test was made on the "Oshoro Maru" in May 1963, with the first model having a circular mouth frame which could be closed by a spring system. It was proved that the operation was very easy, but that the spring was not effective in closing the net against the flow of water. The second test with a modified net having a square net without any spring system (presented in this paper), was made on the "Ryofu Maru" in June 1963. Unfortunately the only wire cable available was very thin (2.8 mm dia.), and it broke when five nets were horizontally hauled losing the bottom three nets. However, the upper two nets showed apparently good performance. The simple type of the messenger weight and wire clip used is shown in Pl. III, Figs. 3 and 4 respectively.

#### IV. Wire clinometers

Wire clinometer with two arms (Fig. 9, Pl. IV, Fig. 3):

In plankton net hauls, whether vertical, horizontal or oblique, it is extremely important to measure the angle of wire cable suspending the net as accurately as possible, in order to know the level of water at which the net is actually operating. Certain types of self-recording depth meters may be available to register exactly

the depth which net has reached, and in net hauls through deep water such meters should preferably be employed. However, in routine samplings, simplicity of gear and operation as a practical thing is desired. It has been felt that wire clinometers which have been commonly used in oceanographic work on Japanese ships are sometimes inconvenient in net hauls because of their small size. The wire cable is frequently suspended outboard from the top of the high davit, and observers, in such cases, have to estimate the inclination of the wire at some distance by keeping the clinometer parallel to the wire cable. A clinometer shown in Fig. 9, Pl. IV, Fig. 3 has two arms on the upper side, and when these arms are extended, it measures one meter in total length.

It being so long, observers can keep the clinometer more easily parallel to the wire cable (Fig. 9, A). By depressing the lock of the semicircular stopping bar with the thumb, the pendulum weight can be fixed at that position. The trial model is made of iron plate, a total weight of 5 kg. It would be better if it were made of light metal. If continuous observation of the angle of the wire cable on deck during the horizontal haul with nets at certain depths, the clinometer can be suspended from the wire near the davit (Fig. 9, B).

**Underwater wire-clinometer (Fig. 10, Pl. IV, Fig. 4):**

The angle of the wire cable at a certain depth can simply be recorded by means of a very clever device using Perspex bottles filled with gelatine solution (Carruthers 1959), but it is somewhat of a nuisance that gelatine solution must be prepared for every sampling. The clinometer presented here, 1 kg in weight, was designed employing the same device as in the case of the above-mentioned "Wire-clinometer having two arms." The release of the stopping bar is obtained by the striking of a messenger weight. On the cruise of the "Oshoro Maru" in the Okhotsk Sea in August 1963, when the angle of the wire cable suspending a 45 cm North Pacific standard net and a 10 kg sinker at 150 m depth, was measured as 30 degrees or more on deck, and underwater wire-clinometer attached to the

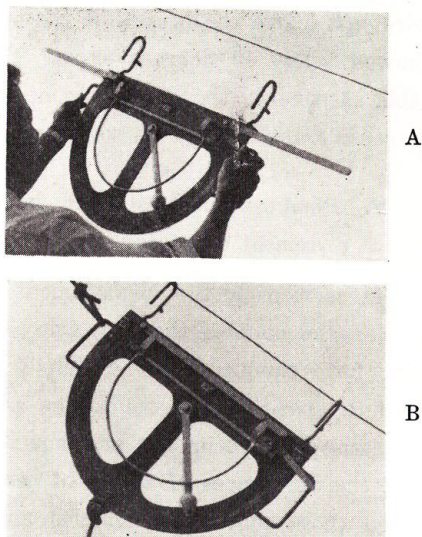

Fig. 9. Wire-clinometer with two arms  
 A. Measuring the angle of wire at a distance by keeping the clinometer parallel to the wire cable  
 B. Wire-clinometer suspended from the wire cable during the haul of the net

wire just above the bridles of the net often showed below 10 degrees or so. The wire cable suspending the net was considered to be considerably curved on some occasions.

#### V. Plankton sample strainer and displacement measuring apparatus

In measuring the displacement volume of plankton samples, there are two problems, *viz.*, how samples can be dehydrated as much as possible but not to the extent of damaging the specimens, and how one can read the differences of levels of water between those containing samples and those not, as accurately as necessary.

##### Plankton sample strainer (Pl. IV, Fig. 5):

It was felt that "Plankton sample aspiration apparatus" (Motoda 1959) could be modified to a more simple construction. The model presented here is merely composed of a set of two plastic cylinders. Bolting cloth of appropriate mesh is put between the upper and lower cylinders, and the water containing the sample is poured onto the cloth. Pressure inside the lower cylinder is reduced by aspirating the air through the upper tube of the lower cylinder, making filtration effective. During the aspiration it is necessary to press down the upper cylinder to make the connection between the two cylinders air tight. Then, if necessary, the cloth with the sample on it is transferred to the blotting paper to soak away the water attached to the surface of animals and remaining in the interstices among the animals. This simple type of apparatus was proved more convenient than the previously reported "Sample aspiration apparatus" (Motoda 1959).

##### Plankton sample displacement measuring cylinder (Pl. IV, Figs. 6, 7):

The main purposes of this device are: to measure the displacement volume of a zooplankton sample of a considerable size, and to read the levels of water in a narrow burette instead of a wide graduated cylinder. Fig. 6 shows a simple type of this apparatus. A burette is attached to the plastic sample container. The bottom plate of the container can be tightly screwed to the container. The procedure for measuring is as follows: the water is poured from the top of the burette into the container up to the zero mark on the burette. After putting a cap on the top of the burette, the container is kept in an inverted position, and the bottom plate is removed. The filtering cloth used for straining the sample

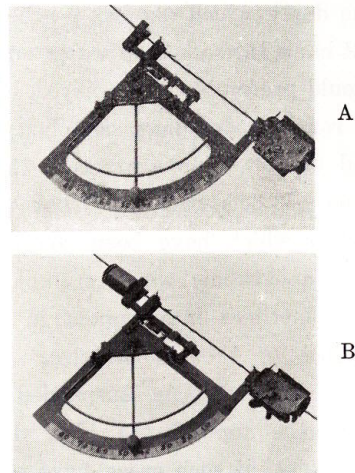

Fig. 10. Underwater wire-clinometer  
A. Before messenger is lowered  
B. After messenger was lowered;  
pendulum weight was fixed.

(Pl. IV, Fig. 5) and the sample on it are placed in the container, and the bottom plate is screwed on. The container is then placed in its original position. The level of water reached in the burette will indicate the displacement volume of the sample and the filtering cloth. The displacement volume of the filtering cloth should be subtracted from the result.

Pl. IV, Fig. 7 (Motoda-Kawamura apparatus) illustrates a more convenient, but slightly more complicated type of a similar apparatus. The sample container is placed below the burette, and the water is introduced from the branch tube by opening the cock until the zero mark is reached on the burette. The container is then raised; the water in the container will thus go down to a certain level. The cover plate is removed, and the sample and the filtering cloth are placed in the container. Then the container is capped and again placed below the burette. The level of water read on the burette indicates the total displacement volume of the sample and the filtering cloth. The marks, 0' or 0'', can be used instead of zero mark, according to the total size of the sample. In this case the volume of water to be contained in the rubber and glass tubes between 0 and 0' or 0 and 0'' should be read prior to the measurement.

The author greatly appreciates the assistance of Messrs. Takashi Minoda, Akito Kawamura and Keisuke Osawa and crew members of the "Oshoro Maru" and the "Ryofu Maru" in the performance tests of various marine contraptions at sea. He also offers thanks for valuable suggestions given by Dr. Teruyoshi Kawamura on the devices for displacement measuring of plankton samples.

#### References

- Bé, A. W. H., M. Ewing and L. W. Linton, 1959. A quantitative multiple opening-and-closing plankton sampler for vertical towing. *Jour. Cons.* 25 (1), 36-46.
- Bé, A. W. H. 1962. Quantitative multiple opening-and-closing plankton samplers. *Lamont Geolog. Obs.* No. 561. *Instrumental Notes*, 144-151.
- Carruthers, J. N. 1959. Simple devices for studying the geometry of various gears and for relating some commercial fishing operations to the existing water movements. *Modern Fishing Gear of the World*, edited by H. Kristjonsson, FAO. *Intern. Fishing Gear Cong. Hamburg*, October 1957. ref. to pp. 254-255.
- Clarke, G. L. and A. F. Bumpus, 1950. The plankton sampler. An instrument for quantitative plankton investigations. *Amer. Soc. Limnol. Oceanogr. Spec. Publ.* 5, Revised, 1-8.
- Motoda, S. 1959. Devices of simple plankton apparatus. *Mem. Fac. Fish., Hokkaido Univ.* 7 (1/2), 73-94.
- Motoda, S. 1962. Plankton sampler for collecting uncontaminated materials from several zones by a single vertical haul. *Rapp. Proc.-Verb.* 153, 55-58.

Paquette, R. G. and H. F. Frolander, 1957. Improvements in the Clarke-Bumpus plankton sampler. *Jour. Cons.* 23, 284-288.

Paquette, R. G., E. L. Scott and P. M. Sund, 1961. An enlarged Clarke-Bumpus plankton sampler. *Limnol. Oceanogr.* 6 (2), 230-233.

## PLATE I

### Double release mechanism and hinged double vertical square net

Fig. 1. Double release mechanism

A. Plan and profile

B. Messengers and release mechanism

a. Second messenger, b. First messenger, c. First trigger, d. Space for second trigger, e. Second trigger, f. Second line, g. First line, h. Third line

C. First (below) and second (above) messengers, plan and section

Fig. 2. Hinged double square net

A. Plan and profile

B. Whole assembly of net

C. Hauling position before the first messenger is lowered

D. Hauling position after the first messenger was lowered

E. Hauling position after the second messenger was lowered

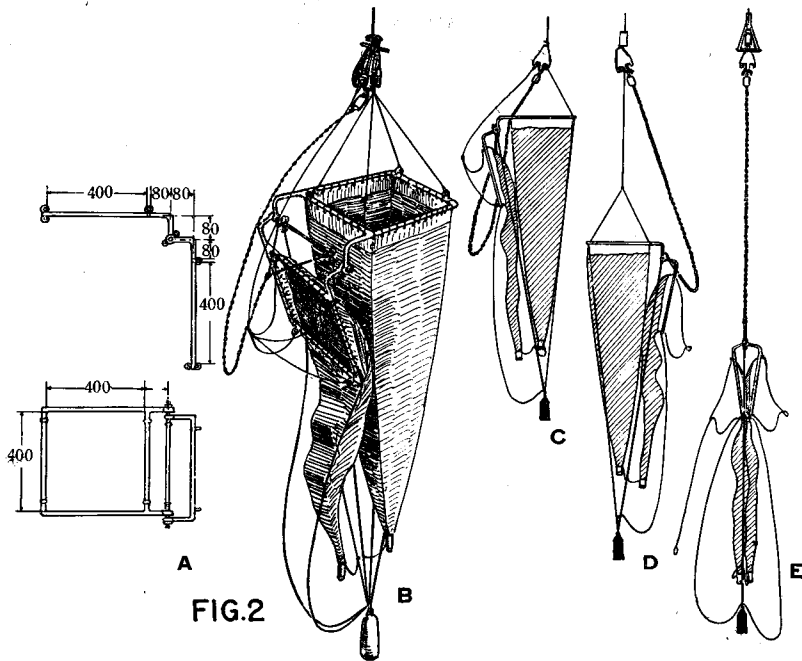
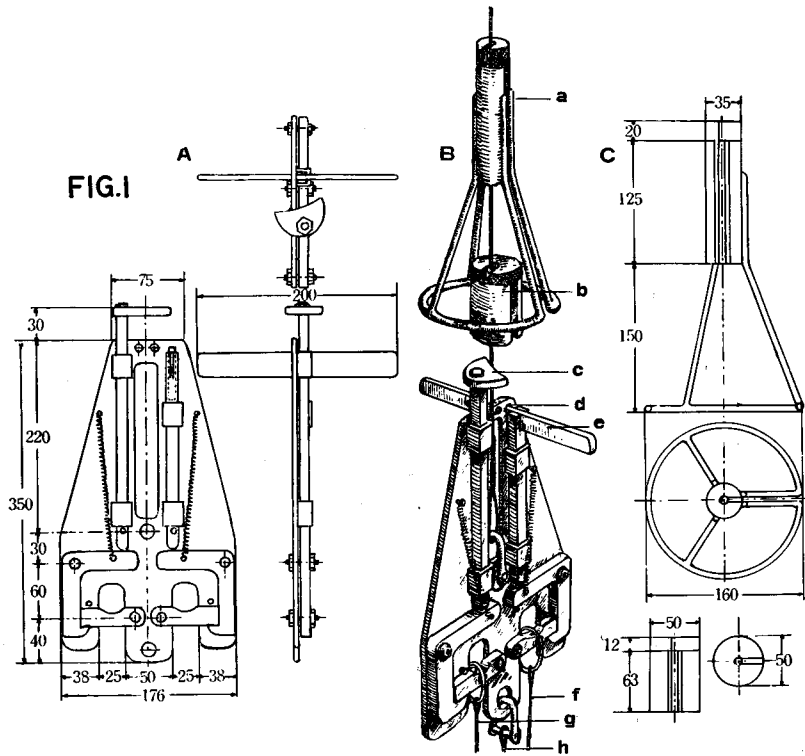

S. Motoda: Simple Plankton Apparatus II

## PLATE II

### Triple release mechanism and multiple collapsible vertical net

Fig. 1. Triple release mechanism and messenger

- A. Upper part of messenger guide of triple release, profile and longitudinal section
- B. Sections of messenger guide
- C. Triple release mechanism
- D. Messenger, plan and profile
- E. Insert rod (above) and a set of messenger (below)

Fig. 2. Triple release mechanism and upper portion of the net

Fig. 3. Multiple collapsible cod end of the net

- A. Lateral side of iron cage holding cylindrical cod end
- B. Frontal side of iron cage
  - a. Third line, b. Second line, c. First line, d. Sliding weight, e. Sliding weight guide
- C. Cylindrical cod end
- D. Sketch of iron cage
  - a. First line, b. Second line, c. Third line, d. Net, e. Collapsed net, f. Sliding weight kept by third line, g. Sliding weight guide, h. Sliding weight slid down



## PLATE III

### Horizontal square net fixed on triangular frame

Fig. 1. Triangular frame and mouth frame, plan and profile

a. Trigger, b. Bridle, c. Rotating arm, d. Short arm of mouth frame, e. Central axis of triangular frame, f. Mouth frame, g. Axis of rotating arms, h. Wire clip, i. Messenger for deeper net

Fig. 2. Clinometer box to be attached to triangular frame

Fig. 3. Simple messenger weight

Fig. 4. Simple wire clip



## PLATE IV

### Horizontal square net fixed on triangular frame

- Fig. 1. Sketch of assembly  
a. Trigger, b. String keeping messenger for deeper net, c. Central axis of triangular frame, d. Wire clip, e. Messenger for deeper net, f. String keeping semicircular stopping bar of clinometer, g. Clinometer box, h. Bridles, i. Mouth frame, j. Rotating arm, k. Cod end supporter, l. Net, m. Axis of rotating arms, n. Short arm of mouth frame
- Fig. 2. Diagrammatic sketch of horizontal square net fixed on triangular frame seen from above  
A. Open position  
B. Closed position  
a. Wire cable, b. Triangular frame, c. Bridle, d. String keeping semicircular stopping bar of clinometer, e. Bridle, f. Mouth frame, g. Rotating arm, h. Cod end supporter, i. Net
- Fig. 3. Wire-clinometer with two arms, plan and profile  
a. Spring, b. Arm, c. Arm, d. Supporting angle plate, e. Supporting angle plate, f. Semicircular stopping bar, g. Pendulum
- Fig. 4. Underwater wire-clinometer, plan and profile  
a. Trigger, b. Wire hanger, c. Short lever to lift stopping bar, d. Pendulum, e. Stopping bar which pushes the pendulum when the short lever (c) is released
- Fig. 5. Plankton sample strainer  
A. Plan and profile  
B. Sketch of assembly  
a. Upper cylinder, b. Bolting cloth, c. Tube for aspiration, d. Lower cylinder, e. Tube for drainage
- Fig. 6. Sketch of simple type of plankton sample displacement measuring cylinder  
a. Cap, b. Burette, c. Rubber plug, d. Tapered hole of rubber plug, e. Sample container, f. Rubber packing, g. Bottom plate
- Fig. 7. Plankton sample displacement measuring apparatus (Motoda-Kawamura apparatus)  
A. Sample container, plan and profile  
a. Rubber packing  
B. Sketch of assembly of apparatus  
a. Cover plate, b. Sample container, c. Mark O'', d. Rubber tube, e. Glass (or plastic) tube, f. Mark O', g. Rubber tube, h. Burette, i. Mark O, j. Rubber plug k. Branch tube, l. Cock, m. Supporter

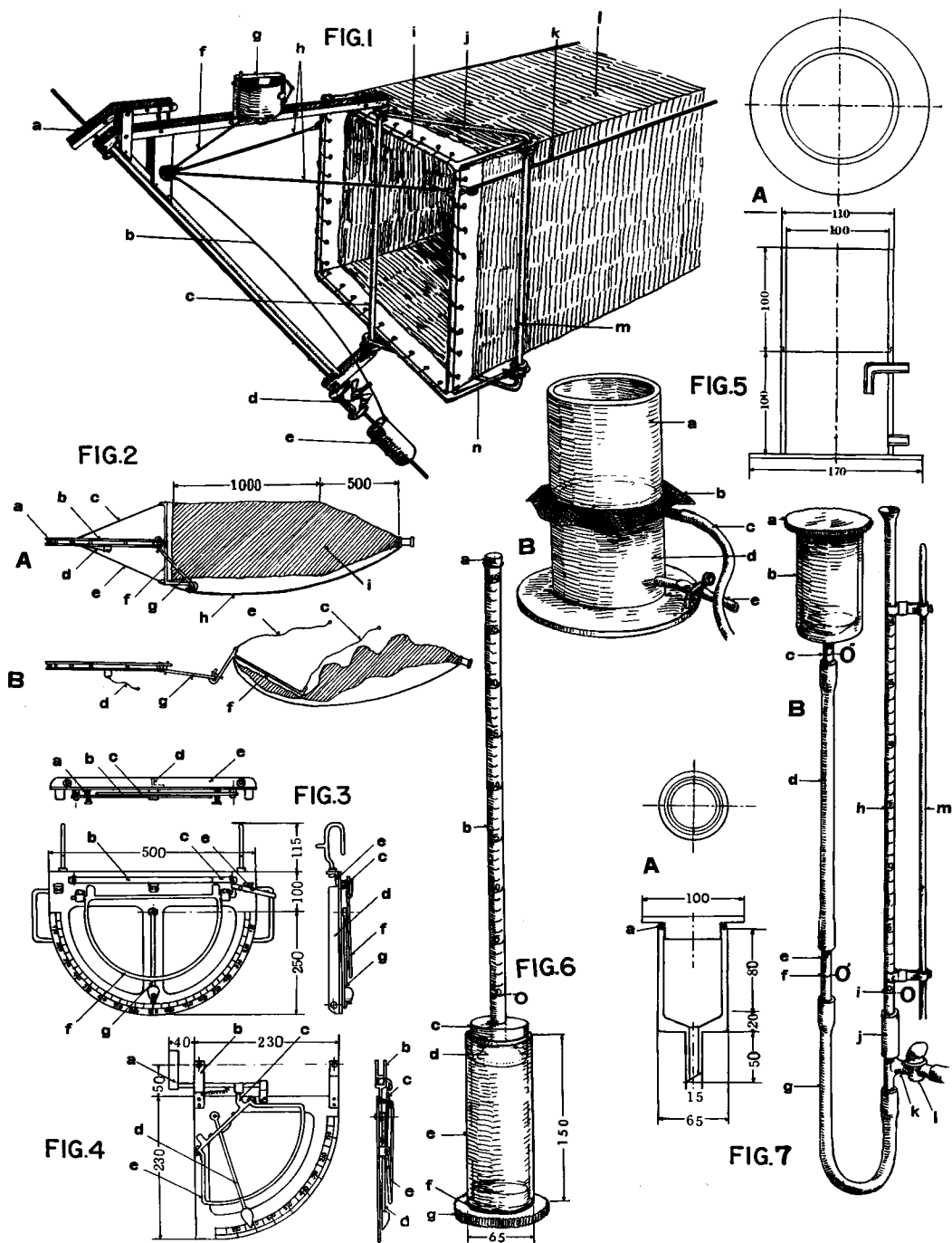

S. Motoda: Simple Plankton Apparatus II