



# HOKKAIDO UNIVERSITY

Title	An Instrument for the Automatic Determination of Auditory Thresholds in Single Neurons
Author(s)	SAWA, Masahiro; 沢, 正博
Citation	北海道大學水産學部研究彙報, 30(1), 14-22
Issue Date	1979-02
Doc URL	<a href="https://hdl.handle.net/2115/23669">https://hdl.handle.net/2115/23669</a>
Type	departmental bulletin paper
File Information	30(1)_P14-22.pdf



## An Instrument for the Automatic Determination of Auditory Thresholds in Single Neurons

Masahiro SAWA\*

### Abstract

An electronic system was designed which facilitates automatic determination of auditory threshold in single neurons. It consists of a response detector which is capable of rapid and accurate distinction of critical responses and an automatic attenuator which raises or lowers the sound intensity according to the absence or presence of signal from the response detector.

A trial experiment using this device was performed with auditory neurons of goldfish. It proved to be effective in determining accurate thresholds in a minimum amount of time.

### Introduction

The determination of auditory thresholds in unit neurons is an essential step in studies of the mechanism of hearing. The threshold should be determined by an exact and constant detection of responses to a given sound intensity. A relatively clear-cut response is detected by observing an oscilloscope or a sound monitor, but a critical response near the threshold is usually difficult to distinguish. Photographic recording is advantageous for discrimination of such a critical response, but it generally requires much time and effort for processing materials and analyses of the data. The discharge rate of a single neuron is not stable near the threshold intensity, and the threshold of a single neuron to a given frequency is usually defined as the lowest level of stimulus at which the rate of evoked discharge is above the background rate. Therefore, repeated trials with many up-and-down sweeps are necessary to determine the threshold accurately. The up-and-down procedure with manual sweepings of sound intensity has been employed in most behavioral investigations<sup>1-6)</sup>, but it is inconvenient in an electrophysiological study when a large number of neurons are to be examined.

A system which facilitates automatic determination of auditory threshold in single neurons was designed. It consists of an electronic response detector which is capable of rapid and accurate distinction of critical responses and an automatic attenuator which controls up-and-down sweepings depending on signals from the response detector. A trial experiment using this device was performed with auditory neurons of goldfish.

---

\* *Laboratory of Physiology and Ecology, Faculty of Fisheries, Hokkaido University*  
(北海道大学水産学部生理学生態学講座)

Present address: *Department of Ophthalmology, Sapporo Medical College, Sapporo 060*  
(札幌医科大学眼科学教室)

### Design of the Apparatus

#### Response detector

A series of action potentials of neurons are converted into standard pulses of the same amplitude and width by means of the Schmidt trigger circuit and a monostable multivibrator<sup>7)</sup>, and then fed into the response detector. The detector consists of an F-V converter, a pair of peak detectors and a comparator (Fig. 1).

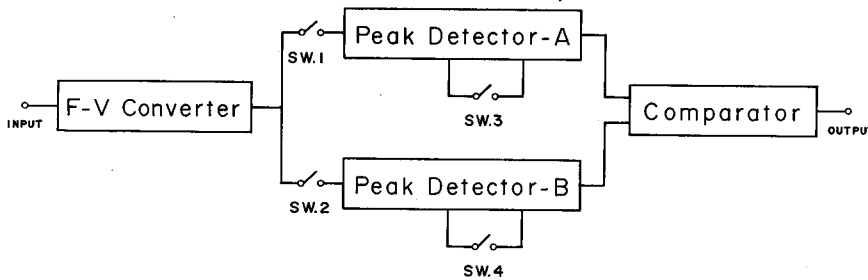

Fig. 1. Block diagram of the response detector.

Through the F-V converter, the pulse train is converted to a DC voltage change according to the frequency of the input signal. At a period before the onset of sound stimulus  $SW_1$  is closed, then the output of the F-V converter is fed into the peak detector-A which detects the peak voltage of the input signal. This potential is held in the peak detector-A while conducted to one of the inputs of the comparator. Simultaneously with the onset of stimulus,  $SW_1$  is opened, whereas  $SW_2$  is closed. The output of the F-V converter is fed into the peak detector-B, and the detected peak voltage is led to the other input of the comparator. If the voltage detected by the peak detector-B exceeds that held by the peak detector-A, the polarity of the output of the comparator is reversed. In other words, if the rate of input pulses during the stimulation is higher than that before the onset of stimulus, a shift of the polarity occurs at the output of the comparator indicating the presence of responses to the stimulus. The  $SW_2$  is opened at the end of the stimulus. Then  $SW_3$  and  $SW_4$  are closed. Consequently, the voltages held by the peak detectors are cleared to the base voltage fixed at near 0 V, and the system is reset for the next step. The input and output signals of the F-V converter and control pulses which close or open the switches ( $SW_1$ ,  $SW_2$ ,  $SW_3$  and  $SW_4$ ) are shown in Fig. 2 with the timing diagram for the sound stimulus.

Figure 3 shows a wiring diagram of the response detector. The resistor-capacitor time constant ( $R \times C$ ) of the F-V converter is reflected in the response time of the output DC potential<sup>7)</sup>. A small time constant responds quickly to a change of the input signal, but it is disadvantageous for conversion to DC voltage particularly at a lower frequency of input pulses. If the time constant is increased, a smoother DC potential output is obtained, but the sensitivity to a rapid change of input signal is reduced. Four different time constants can be selected in the device according to the frequency component of the input signal. The conver-

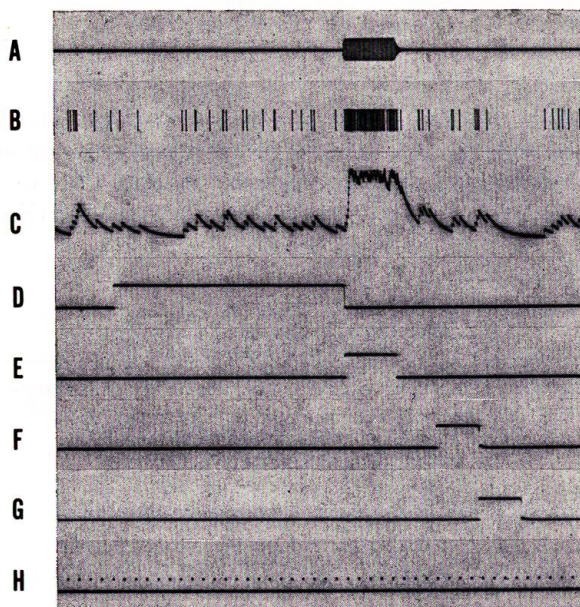

Fig. 2. Temporal process of control pulses to close or open switches ( $SW_1$ ,  $SW_2$ ,  $SW_3$ , and  $SW_4$ ). A, sound stimuli; B, recorded discharge converted into a standard pulse; C, output signal of the F-V converter; D, E, F, and G, control pulses for  $SW_1$ ,  $SW_2$ ,  $SW_4$ , and  $SW_3$ , respectively; H, pulse train of 20 Hz for a time display.

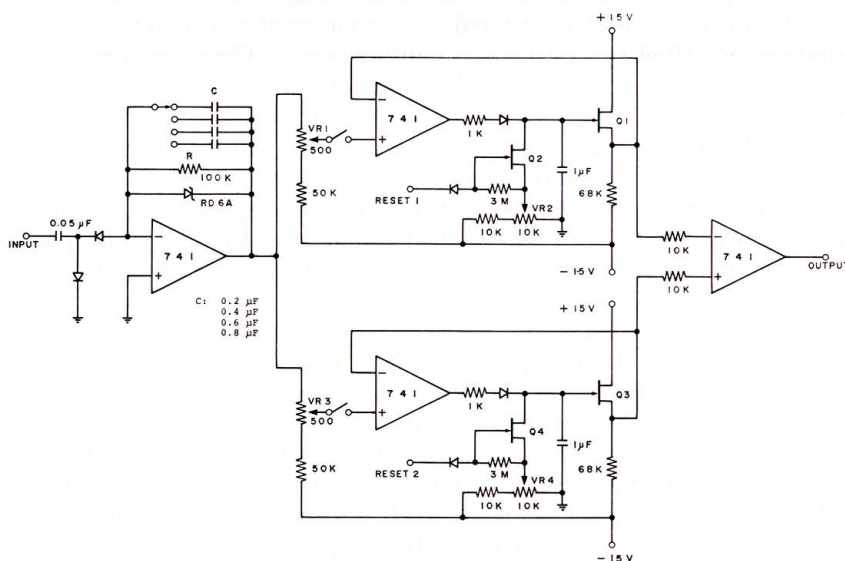

Fig. 3. Wiring diagram of the response detector. The four operational amplifiers ( $\mu A741$ ) are used for the fundamental devices.  $Q_1$  and  $Q_2$  (2SK15) are used as source followers with a high input impedance.  $Q_3$  and  $Q_4$  (2SK30) are applied to set up semiconductor switches.

tion rate of the F-V converter was measured at the time constant of 60 msec ( $R=100\text{ K}$ ,  $C=0.6\ \mu\text{F}$ ). If the frequency of the input pulses is raised from 10 Hz to 100 Hz, the output potential was increased from 0.6 V to 3.1 V. The voltage is altered about 28 mV by a change of 1 Hz in the pulse rate. The voltage difference of 28 mV is enough for the sensitivity of the comparator. In practical use, the sensitivity of the response detector is adjusted by setting the relative attenuation levels of variable registers,  $VR_1$  and  $VR_2$ . The  $VR_3$  and  $VR_4$  are to set the base voltages of the peak detector-A and -B at the reset, respectively. The  $VR_1$  is fixed at 0V, while the  $VR_3$  is set at a few mV higher than 0 V to settle the polarity at the output of the comparator.

Automatic attenuator

A block diagram and the wiring diagram of the automatic attenuator are shown in Figs. 4 and 5, respectively. The decimal counter (SN74190N, TI) has two functions, as an up counter and a down counter. Keeping "L" level at a pin of mode control in the counter, the count goes up at every count pulse. On the contrary, the counter acts as the down counter with the "H" level at the mode control pin. A pulse generated by the monostable multivibrator is used to settle the count mode either up or down. If the response is "positive", the output signal of the response detector triggers the monostable multivibrator. Subsequently, the mode control of the counter is settled at "H" level, and then the down count is performed. If the response is "negative", the monostable multivibrator is not activated, and the mode control pin is kept at "L" level. In this case, the counter is set for up count. Aiming at a simple circuit design, the duration of the mode control pulse depends only on the pulse duration which is determined by the time constant ( $R \times C$ ) of the monostable multivibrator. Therefore, a rough adjustment of the time constant is needed to terminate the pulse after the entrance of the count pulse but before the onset of the next stimulation (Fig. 6). The output of the counter is given by BCD (Binary Corded Decimal) cord, and it is transformed to the decimal cord by the BCD-decimal decoder (SN7445N, TI). The

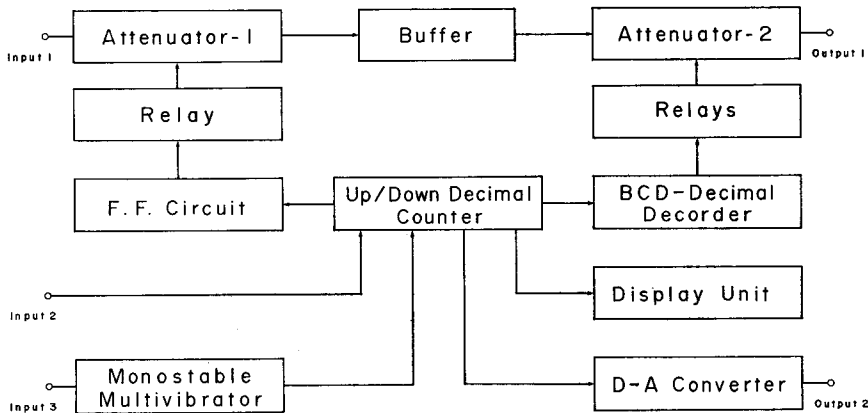

Fig. 4. Block diagram of the automatic attenuator.

decoder has ten outputs each of which is led into ten relays, respectively (Fig. 5). Contact points of the relays are connected to the attenuator-2 which consists of nine units of semifixed registers arranged in degree of attenuation by 2.5 dB steps.

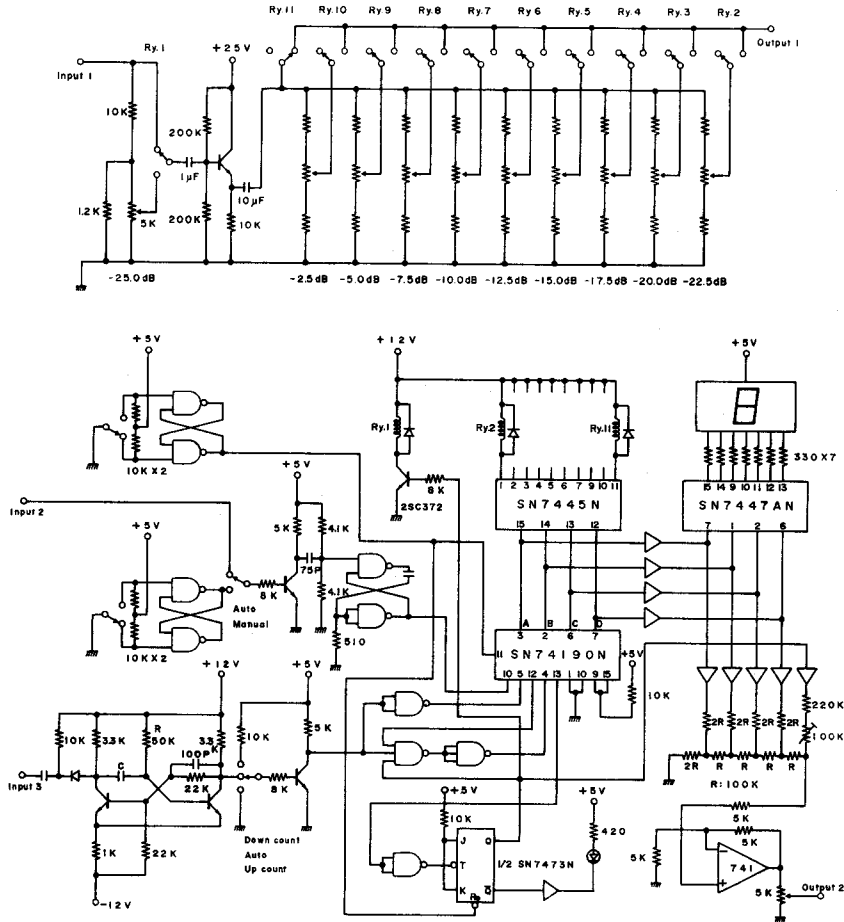

Fig. 5. Wiring diagram of the automatic attenuator. NAND gate with two inputs is SN7400N, and that with three inputs is SN7410N. A converter is formed by a combination of the two NAND gates (SN7400N), but MC14010 is used at the circuit of the D-A converter.

When the output signal of the counter is supplied into the decoder, only one pin of the ten outputs of the decoder is "ON" and others are all "OFF" in response to the counted number from "0" to "9". The relay connected to that "ON" pin activates one circuit of the semifixed register which has a set rate of attenuation. In this way, the sound intensity is altered up or down according to the signals of the counter. The intensity of the sound signal is altered also by the attenuator-1 which is controlled by the output pulse of the flip-flop circuit through the relay.

SAWA: Instrument for auditory threshold determination

If the counted number reaches "0" on the down count, or "9" on the up count, a pulse comes out of one pin of the counter (O/U in Fig. 6). This pulse is utilized to trigger the flip-flop circuit. At every arrival of the trigger, the output of the

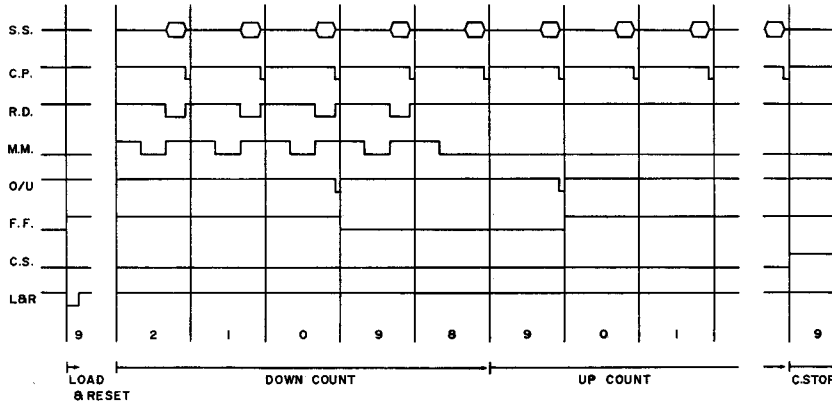

Fig. 6. A timing chart of the sound stimulus and pulses to operate the counter. S.S., sound stimuli; C.P., count pulse; R.D., output of the response detector; M.M., output of the monostable multivibrator; O/U, pulse on the over flow or the under flow; F.F., output of the flip-flop circuit; C.S., pulse for the count stop; L&R, pulse for the load and the resetting.

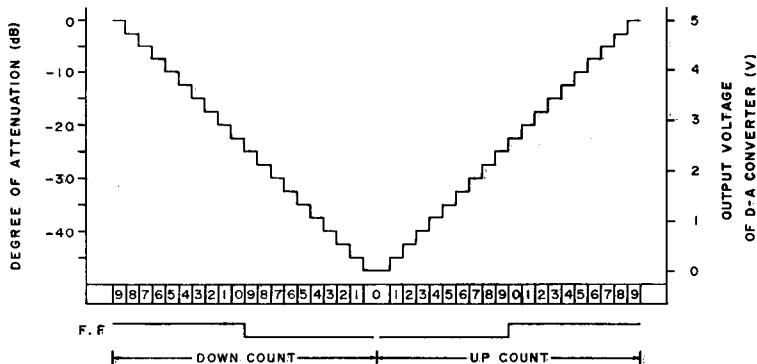

Fig. 7. Relationship of the degree of the attenuation in the attenuator and output voltage of the D-A converter against the counting process in the counter and the output mode of the flip-flop circuit.

flip-flop circuit turns over either "H" or "L" level against the original level. The attenuator-1 is activated by "H" at the output of the flip-flop circuit. Consequently, the sound intensity is decreased by 25 dB.

When the up count reaches "9", the counting stops on condition that the output of the flip-flop circuit is kept at "H" level (C.S. in Fig. 6). In case of the down count, however, the counting is repeated without end. By supplying a pulse

for "Load and Reset", the counter turns back to "9" from any counted number, and at the same time the output of the flip-flop circuit is reset to "H" level (L&R in Fig. 6). The relationships between the outputs of the counter, the flip-flop circuit, the D-A converter and the attenuators are shown in Fig. 7. The attenuation which is nothing at counted number "9" is augmented by 2.5 dB with every

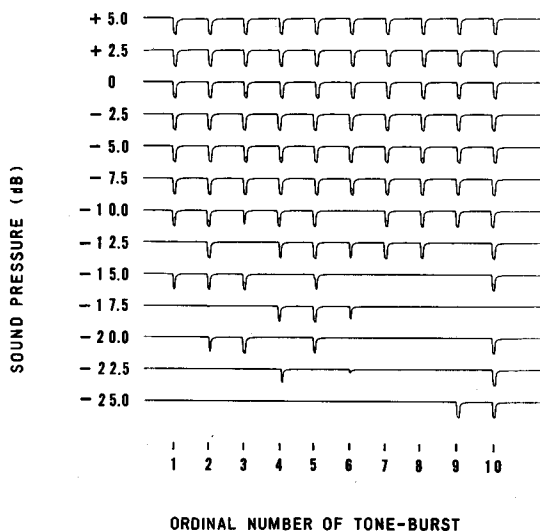

Fig. 8. Responses of acoustic units of a goldfish obtained by use of the response detector.

down step to "0". When at "9" again, attenuator-1 with the attenuation rate of 25 dB functions, and the down count progresses once again to "0" where the total attenuation of the system has maximum value of 47.5 dB. The output voltage of the D-A converter also changes step by step in response to the counted number. The intensity of the stimulus is therefore followed by recording the output of the D-A converter.

### Application of the Apparatus

Multi-neuronal activity to sound stimuli recorded from the medulla oblongata in goldfish using the response detector is shown in Fig. 8. The intensity of the sound was lowered by 2.5 dB after ten stimuli. The "positive" responses are indicated as negative pulses in the traces. At intensities above -7.5 dB, "positive" responses were observed at every stimulus. When the sound intensity was lowered further, responses were less frequent. Some of the negative pulses observed at lower intensities were probably artifacts because those pulses, usually 3 or 4 in ten trials, were emitted without the sound stimuli. The threshold is therefore to be defined as the lowest sound pressure to give more than five positive responses out of ten trials.

The auditory thresholds of the medulla units of a goldfish were examined using the automatic attenuator connected with the response detector. An

SAWA: Instrument for auditory threshold determination

example obtained with two different units is shown in Fig. 9. The stimulation started at +20 dB. At the beginning, the "positive" responses were obtained at every stimulus and consequently the sound intensity went down step by step. After the stimuli at -7.5 dB in the unit A and -10 dB in the unit B, up-and-down sweeps of sound intensity were observed as a function of the presence or absence of

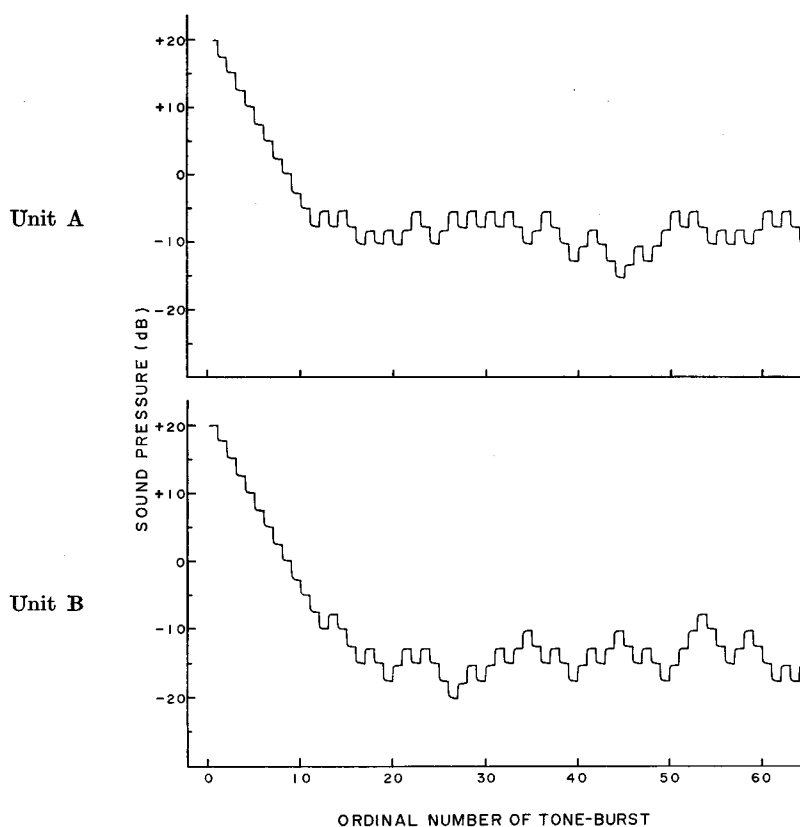

Fig. 9. Recordings of the up-and-down course of the sound intensity managed by the automatic attenuator with the response detector for acoustic responses in medulla units of a goldfish. Frequency of the sound is 200 Hz.

the response. The thresholds were calculated by averaging the sound intensities of every stimulus in the sweeps. The thresholds were determined to be -8.1 dB in the unit A and -13.8 dB in the unit B.

Fluctuations of the up-and-down sweeps showed that the rate of impulses near the threshold intensity was not stable relative to background activity. Therefore, an exact determination of the threshold should be made by analysing a large number of responses. The automatic attenuator, connected with the response detector proved to be effective in obtaining the accurate thresholds in a minimum amount of time.

### Acknowledgments

The author wishes to express his great thanks to Professor Jurō YAMADA of the Faculty of Fisheries, Hokkaido University, for his kind guidance in the course of the work. Kind revision of the manuscript by Professor Masami ISHIDA, Faculty of Fisheries, Hokkaido University, and by Professor John M. DEAN, University of South Carolina, are greatly acknowledged.

### References

- 1) Jacobs, D.W. and Tavolga, W.N. (1967). Acoustic intensity limens in the goldfish. *Anim. Behav.* 15, 324-335.
- 2) Weiss, B.A. (1969). Lateral-line sensitivity in the goldfish. *J. Aud. Res.* 9, 71-75.
- 3) Iversen, R.T.B. (1969). Auditory thresholds of the scombrid fish *Euthynnus affinis*, with comments on the use of sound in tuna fishing. *FAO Fisheries Reports* 62, 849-859.
- 4) Offutt, G.C. (1974). Structures for the detection of acoustic stimuli in the Atlantic codfish, *Gadus morhua*. *J. Acoust. Soc. Am.* 56, 665-671.
- 5) Chapman, C.J. and Sand, O. (1974). Field studies of hearing in two species of flatfish, *Pleuronectes platessa* (L.) and *Limanda limanda* (L.). *Comp. Biochem. Physiol.* 47, 371-385.
- 6) Popper, A.N. and Clarke, N.L. (1976). The auditory system of the goldfish (*Carassius auratus*): Effects of intense acoustic stimulation. *Comp. Biochem. Physiol.* 53, 11-18.
- 7) Buchwald, J.S., Holstein, S.B. and Weber, D.S. (1973). Multiple unit recording: Technique, interpretation, and experimental applications. p. 201-242. In Thompson, R.F. and Patterson, M.M. (ed.), *Bioelectric Recording Techniques*, Part A. Academic Press, New York.