



HOKKAIDO UNIVERSITY

Title	A Preliminary Note on Pot Selections for the Size of the Rock Crab
Author(s)	WATANABE, Yasuhiro; 渡辺, 安広; SASAKAWA, Yasuo et al.
Citation	北海道大學水産學部研究彙報, 35(4), 225-233
Issue Date	1984-11
Doc URL	https://hdl.handle.net/2115/23864
Type	departmental bulletin paper
File Information	35(4)_P225-233.pdf



A Preliminary Note on Pot Selections for the Size of the Rock Crab

Yasuhiro WATANABE* and Yasuo SASAKAWA**

Abstract

Field experiments which included observations in tank conditions were conducted on practical applications of pots to conserve undersized rock crabs *Erimacrus isenbeckii* (Brandt) with 76, 91, 106, 121, 136 mm mesh pots in the bay and open sea adjacent to the mouth of Funka bay, Hokkaido in late Spring and Autumn of 1983.

Results obtained are as follows :

Supplemental observations in tank condition

1) The minimum mesh size Y that a crab could pass through was 1.53 times as long as its carapace length X . Therefore the relation between the mesh circumference $2Y$ and the body circumference $2.7X$ was formulized as follows :

$$2Y = 1.12 (2.7X)$$

2) The mesh size Y' which allowed rock crabs to climb is 3.2 times as long as their carapace length X . Therefore the relation between the height $0.4Y'$ of the middle knot of this mesh and the distance $4X$ between tips of legs stretched outwards was formulized as follows :

$$0.5Y' \sqrt{2S - S^2} = 0.4Y' = 0.32 (4X)$$

S equals the shrinkage of plain nets used.

3) The minimum gap Y'' that a rock crab of carapace length X and body depth $0.83X$ could pass through was expressed by the following formula :

$$Y'' = 0.82X = 0.99 (0.83X)$$

Field experiment with various sized mesh pots

1) The range and mode of carapace length frequency were 42-79 mm and 53 mm in the bay, and were 54-91 mm and 67 mm in the open sea.

2) Catch number per pot decreased as the mesh size increased with the exception of the 91 mm sized mesh pot which caught more than the 76 mm one did in the open sea.

3) Carapace length frequency by the mesh sizes of pots tended to vary in relation to mesh size that is in the range of 76-106 mm in the bay, and was negligible difference between the 76 mm mesh and 91 mm one in the open sea but varied among mesh sizes larger than 106 mm there.

4) Considering that the results of field experiments are in approximate agreement with the observations in tank condition, it is possible to conclude that 121 mm mesh is a reasonable size for a pot to release only undersized rock crabs less than 80 mm in carapace length.

The rock crab, *Erimacrus isenbeckii* (Brandt), is in great demand as a variable marine product from Hokkaido. However, the rock crab stocks have been extremely reduced in number due to overexploitation with pots, bottom tangle nets and demersal seines. Because the stocks were low, the first mass liberation of juveniles was initiated in Funke bay, Hokkaido in 1983.

* Hokkaido Hakodate Fisheries Experimental Station
(北海道立函館水産試験場)

** Laboratory of Operation Technology of Fishing, Faculty of Fisheries, Hokkaido University
(北海道大学水産学部漁具漁法学講座)

It is necessary to improve crab fishing gear in order to reduce the number of undersized crab taken and for the effective utilization of reproductive potential of this stock. A series of supplemental observations in the laboratory and of pot experiments in the fishing ground have therefore been conducted to find the optimum mesh size and gap to release undersized crabs but to retain legal sized ones.

There are many literatures on escapement gap of pots in other countries and some on mesh size in relation to the efficiency of pots for shellfish¹⁾²⁾³⁾. Analysis of the results are only generally reported in this paper.

Acknowledgement is given to many people of Hokkaido Fisheries Experimental Stations, Hokkaido Institute of Mariculture, and the Department of Fishing Science in the Faculty of Fisheries, Hokkaido University for their aid in the accumulation of experimental material and information and for their encouragement.

Material and Methods

Laboratory observations

In Autumn of 1983, supplemental observations in an indoor tank condition were performed to observe the process of crabs passing through meshes or gaps, and to find the optimum mesh size and gap which would permit the release of undersized rock crabs from pots after field experiments were carried out with various sized mesh pots.

Five male crabs of carapace length 46-89 mm and ten juveniles of carapace length 15-27 mm were acclimated in a holding tank for the period of one week. The carapace surface was marked to distinguish individual crabs, and experiments were performed in a glass tank measuring 70 cm × 30 cm × 45 cm deep. Natural sea water and filter used were replaced biweekly. The water temperature, ranging from 8°C to 10°C in regular use, was controlled by a Reisea cooler.

The experimental tank was partitioned into two sections of equal space by using a black plastic plate or plain nets with mesh sizes 24, 44, 64, 91, 121 and 156 in mm (Fig. 1). The behaviors of various sized crabs passing through mesh, climbing up plain net, and passing through gaps between the partition wall and floor of the glass tank were observed and recorded.

After concluding observations in tank condition, various measurements such as carapace length, carapace width, body depth, body circumference, length of each segment of the right third ambulatory leg and chelipeds were taken on thirty eight males of 46-102 mm carapace length and twelve juveniles of 15-27 mm carapace

Table 1. Regression coefficients for body depth, body circumference and the distance between left and right tips of third ambulatory legs stretched outwards on carapace length, measurements being made in mm.

Body part	Individual number	Regression coefficient	80 mm carapace length crab
Body depth	22	0.83	67
Body circumference	10	2.7	216
Distance between tips of legs	15	4.0	320

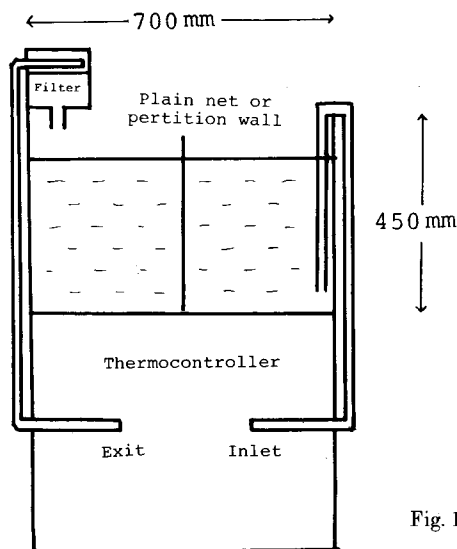

Fig. 1. Diagram of experimental tank.

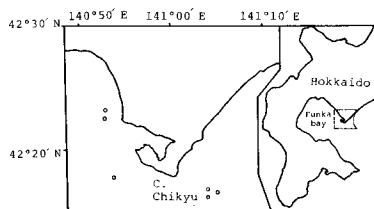

Fig. 2. Map of southern Hokkaido and location of experimental station (open circle).

length. Subsequently the regression coefficients for the above parts were estimated in mm by the method of selected points (Table 1).

Field experiment

Actual operations using pots with various sized mesh were carried out three times in the bay and in the open sea adjacent to the mouth of Funka bay, Hokkaido in the late Spring of 1983 (Fig. 2).

In each operation, 10 pots of each of the following sized mesh were cast: 76 mm (2.5 sun), 91 mm (3.0 sun), 106 mm (3.5 sun), 121 mm (4.0 sun) and 136 mm (4.5 sun). The shrinkage of netting covered the top entry pot used were 0.35-0.45, and is the minimum along the bottom ring of the pot (Fig. 3). Soaking duration ranged from one to three days. Carapace length, carapace width, body weight and sex were recorded on crabs caught in mesh sizes of pots.

Terms used throughout this paper are defined as follows:

Body circumference (2.7 X) - The circumference of cephalo-thorax and abdomen on the line of carapace length.

Body depth (0.83 X) - The distance from the highest part of the dorsal surface of the carapace to the lowest protruding part of the ventral surface of the thorac region.

Carapace length (X) - The distance from the posterior median edge of the carapace to the concavity of the rostrum.

Distance between tips of legs (4 X) - The distance between the left and right tips of third ambulatory legs in stretched outwards.

Legal-sized crab - A rock crab larger than 80 mm in carapace length.

Mesh size - Stretched mesh size.

Bay - The bay adjacent to the mouth of Funka bay, Hokkaido.

Open sea - The open sea adjacent to the mouth of Funka bay, Hokkaido.

Undersized crad - A rock crab with a carapace length less than 80 mm.

Results and Discussion

Laboratory observations

Passing through mesh

A rock crab normally moves sideways just as the common crab generally does. Consequently the mesh size that a rock crab was able to pass through was closely related to the carapace length. When encountering the plain net, the rock crabs at first put their left or right walking legs into the mesh, and then tried to insert their cephalo-thorax and abdomen. When the mesh gap encountered was narrow and less than the carapace length, the crab would align its carapace length with the maximum open space of the mesh, and attempted to pass through the mesh in such postures as the frontal region of carapace up or crawling sideways. Any crab could easily pass through any mesh when the mesh opening was sufficiently larger than the carapace length, but in the case contrary to the above state, when the maximum mesh opening was less than its carapace length the crab struggled to expand the mesh opening by its chelae in order to pass through the netting set up.

The following results were obtained about the maximum sized crab that could pass through the mesh (Fig. 4). The minimum mesh size Y that a crab could pass through was 1.53 times as long as its carapace length X . Mesh selection should be determined by the body circumference rather than the carapace length. From the regression coefficients, the body circumference is about 2.7 times as long as the carapace length, and mesh circumference is expressed as $2 Y$. The following formulae were obtained :

$$Y = 1.53 X \dots\dots\dots(1)$$

$$2 Y = 1.12 (2.7 X) \dots\dots\dots(2)$$

The formula (2) means that a mesh circumference over twelve percent larger

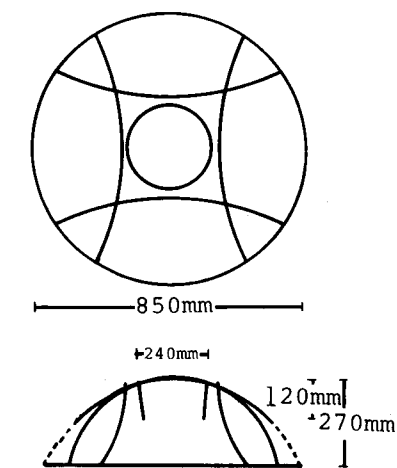

Fig. 3. Plan diagrams of a pot used.

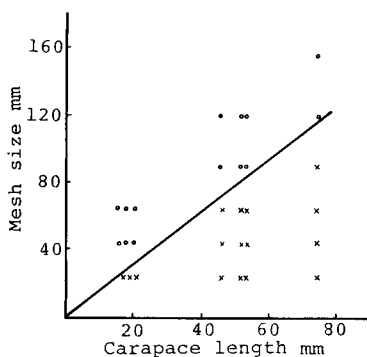

Fig. 4. The relation between carapace length and mesh size that allows rock crab to pass through.
o: Success in passing through
x: Failure in passing through

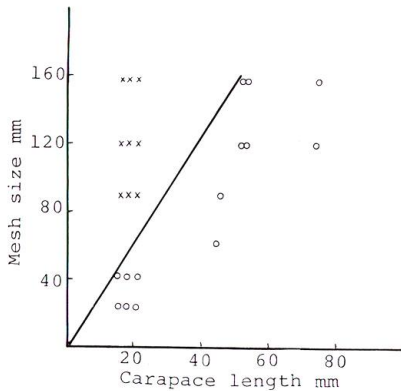

Fig. 5. The relation between carapace length and mesh size that allows the rock crab to climb up.
 o : Success in climbing up
 x : Failure in climbing up



Fig. 6. A rock crab of 47 mm body depth which succeeded to pass through 52 mm gap crawling to the left.

than the body circumference is required for the crab to pass through the mesh. The discrepancy between mesh circumference and body circumference presumably increases as tension of the netting increases.

The legal minimum size for rock crab is 80 mm in carapace length. Any mesh sizes employed in the fishery are preferable to be capable of retaining crabs of this size and above while allowing those below to escape. According to our observations in tank condition, the maximum mesh size that will retain the legal minimum sized crab was approximately 121 mm (4 sun).

Climbing up netting

Crabs sometimes climbed up plain nets set up perpendicularly even if they could pass through the mesh. A crab of 74 mm carapace length easily climbed up the plain net of 158 mm mesh while the crabs of 52 mm and 53 mm carapace length could barely climb to the top (water surface) of the same net. Juveniles of nearly 20 mm carapace length could climb up netting of 40 mm mesh but could not climb that of 90 mm mesh.

Rock crabs could climb up plain net only if the tip of their walking legs could reach a knot of netting in a climbing pose to the left or right. The allowing mesh size Y' for rock crabs to climb is 3.2 times as long as their carapace length X , which is equal to 80% of the distance $4 X$ between tips of legs (Fig. 5). The vertical distance between the ranks of knots on plain nets is $0.4 Y'$ because those shrinkages S are 0.4 on the average. Accordingly, the distance between the ranks of knots which allowed rock crabs to reach corresponds to 32% of the distance between tips of legs, and is formulized as follows :

$$Y' = 3.2 X = 0.8 (4 X) \dots\dots\dots(3)$$

$$0.5 Y' \sqrt{2S - S^2} = 0.4 Y' = 0.32 (4 X) \dots\dots\dots(4)$$

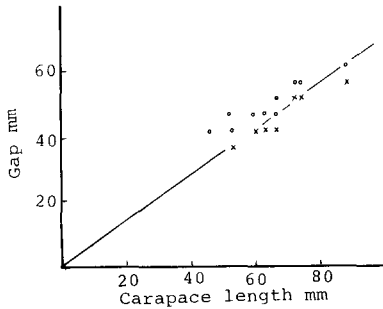

Fig. 7. The relation between carapace length and gap that allows the rock crab to pass through.
 o : Success in passing through
 x : Failure in passing through

In conclusion, any rock crabs (over 50 mm carapace length) caught with pots in the bay and the open sea should be able to climb up any netting below 151 mm (5 sun) in mesh size.

Passing through gap

Most crabs easily passed through even narrow gaps by crawling sideways (Fig. 6) except a couple of crabs which barely passed through extremely narrow gaps by crawling and turning their body upside-down after failing at previous attempts.

The gap width that well permitted passing through for rock crabs averaged 83.5% of their carapace length, 100.8% of their body depth 0.83 X, and for undersized crabs was over 5.6–6.2 cm (Fig. 7). The above observations show that gap selection depends on body depth rather than carapace length. If a gap was to be introduced in a pot to aid undersized crabs in escaping, it might be preferable to make the length of the gap long enough to allow the escape of a few or more undersized crabs at once because, as was observed in tank condition, legal-sized crabs occasionally blocked the gap and prevented undersized crabs from escaping through the gap when they are hard to pass through there.

In conclusion, the minimum gap Y'' that a rock crab of carapace length X and body depth 0.83 X could pass through was formulized as follows :

$$Y'' = 0.82 X = 0.99 (0.83 X) \dots\dots\dots(5)$$

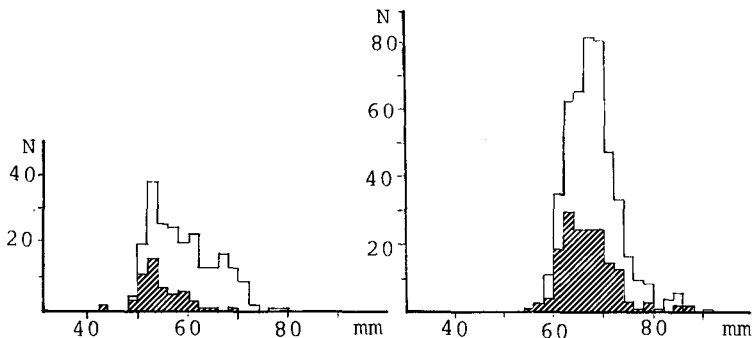

Fig. 8. Carapace length frequency of male and female crabs (shaded section) taken with the experimental pots in the bay (left) and open sea (right).

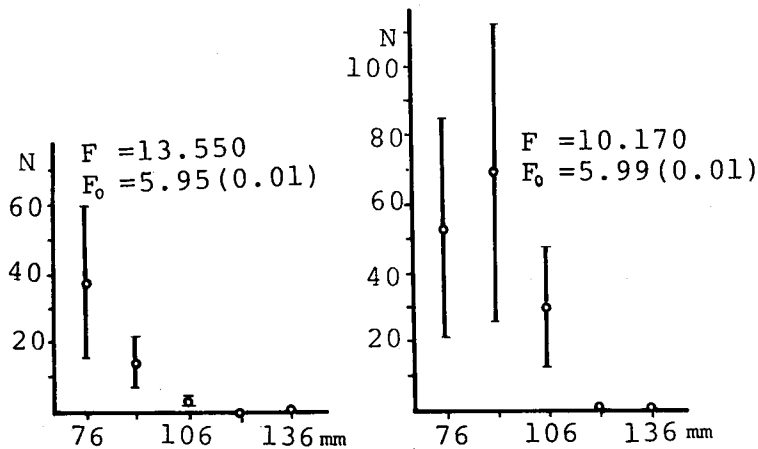

Fig. 9. Mean number and standard deviation of catch per ten pots by the mesh sizes in the bay (left) and open sea (right).

Field experiment

Carapace length frequency

The range and mode of carapace length frequency were 42-79 mm and 53 mm in the bay, and were 54-91 mm and 67 mm in the open sea respectively. The above values in the bay were 10 mm or so less than these in the open sea. Legal-sized crab was not found in the bay, and was very poor as only 2.3% of the total number caught even in the open sea (Fig. 8).

Catch number in mesh sizes

Fig. 9 shows the mean number caught with pots in mesh sizes 76 mm, 91 mm, 106 mm, 121 mm, and 136 mm. Catch number per pot decreased as the mesh size increased with the exception of the 91 mm mesh pot which caught more than the 76 mm one did in the open sea. According to analysis of variance in the catch

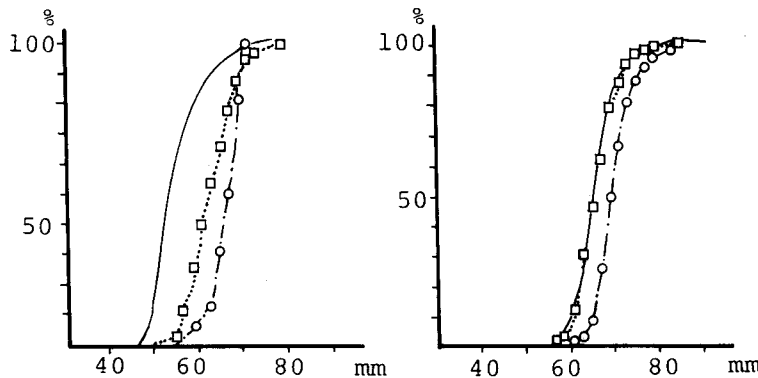

Fig. 10. Accumulative frequency distribution of carapace length in mesh sizes of pots in the bay (left) and open sea (right).

— : 76 mm mesh □ : 91 mm mesh ○ : 106 mm mesh

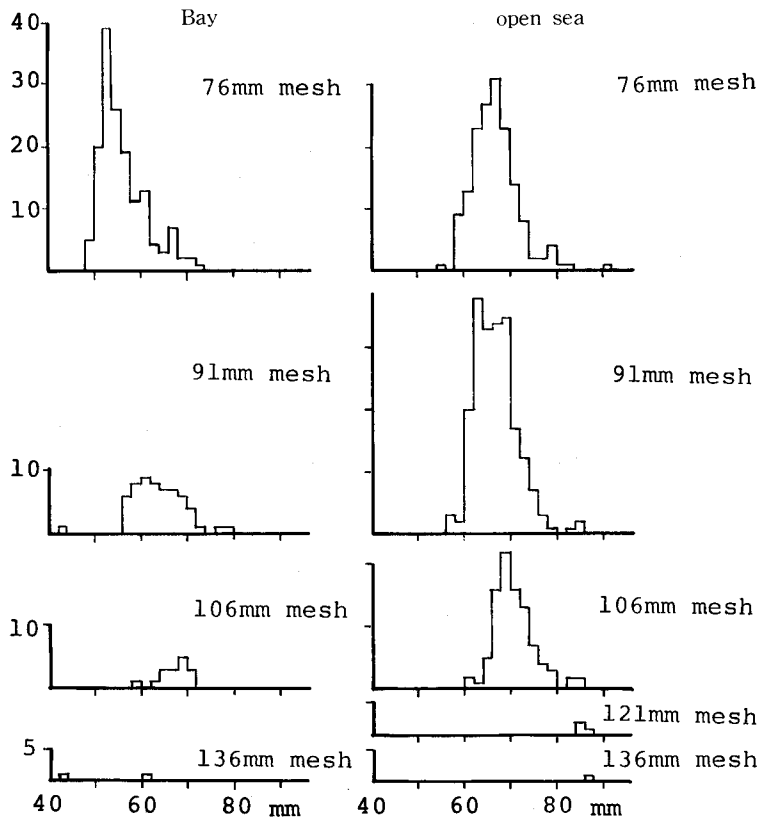

Fig. 11. Carapace length frequency in mesh sizes of pots.

transformed into logarithm, there was a significant difference in the mean number of catches among different mesh sized pots by 99% confidence limitation in the bay and also in the open sea as shown in Fig. 9. Catches in 121 mm mesh pot and 136 mm one were very poor less than 1 individual per 10 pots. This is probably due to the lack of abundance of legal-sized crabs which could retain in the pots with those sized mesh as already described.

Carapace length frequency in mesh sizes

In the bay, carapace length frequency in mesh sizes had a tendency to shift toward the larger carapace length in accordance with mesh size in the range from 76 mm to 106 mm (Fig. 10 and 11).

Such small crabs as 43.6 mm and 61.0 mm carapace length appeared in such large mesh pot as 136 mm. Those crabs apparently had not yet escaped through the mesh before it was hauled, judging from the aforementioned observation in tank condition (Fig. 4). In the open sea the carapace length frequencies did not differ between the 76 mm mesh pot and the 91 mm one but differed among mesh sizes larger than 106 mm. Particularly undersized carabs had not been caught in 121 mm and 136 mm mesh pot.

There was a significant difference in the median of carapace length frequency among different mesh sizes in the bay ($\chi^2 = 40.753$) and in the open sea ($\chi^2 = 21.769$). Difference of mesh selectivity were clear among various mesh size from Figs. 10, 11 and 4 but were little between 76 mm and 91 mm mesh ones in the open sea. The group that passed through 76 mm and 91 mm mesh was limited to crabs smaller than 48 mm and 58 mm in carapace length respectively from formula (1) and Fig. 4. On the other hand 60 mm mode group dominantly distributed in the open sea as shown in Fig. 8. As matter of course the difference of mesh selectivity between the above both mesh sizes did not occur there, and was apparent to the 50 mm mode group in the bay (Fig. 8).

There were too few legal-sized crabs in our research waters to decide accurately the optimum mesh which would retain legal-sized crabs but allow undersized crabs to escape. However, considering that undersized crabs were not caught with 136 mm and 121 mm mesh pots in the bay while the majority caught with 106 mm mesh pot was undersized crabs of 69 mm mode group in the bay as well as in the open sea, and the maximum carapace length that was able to pass through 121 mm mesh in tank condition was 77-81 mm, which was in agreement with the field experiment, we may conclude that 121 mm mesh is the optimum mesh size to use for pot netting that functions to retain legal-sized crabs and to release only undersized crabs.

References

- 1) Brown, C.G. (1982). The Effect of Escap Gaps on Trap Selectivity in the United Kingdom Crab (*Cancer pagurus* L.) and Lobster (*Homarus gammarus* (L.)) Fisheries. *J. Cons. int. Explor. Mer.* **40**, 127-134.
- 2) Sinoda, M. and Kobayashi, T. (1971). Studies on the Fishery of Zuwai Crab in the Japan Sea -VI. Efficiency of the Toyamakago (a kind of Crab Trap) in Capturing the Beni-zuwai Crab. *Bull. Japan. Soc. Sci. Fish.* **35**(10), 948-956.
- 3) Ritchie, L.D. (1966). Crayfish pot escapement gap survey November 1965 - January 1966. *Fish. Tech. Rep. N.Z. Mar. Dep.*, **14**, 1-9.