



HOKKAIDO UNIVERSITY

Title	Studies on Acoustic Target Strength of Squid : I. Intensity and energy target strengths
Author(s)	ARNAYA, I Nyoman; アルナヤ, イニヨマン; SANO, Noritatsu et al.
Citation	北海道大學水産學部研究彙報, 39(3), 187-200
Issue Date	1988-08
Doc URL	https://hdl.handle.net/2115/24002
Type	departmental bulletin paper
File Information	39(3)_P187-200.pdf



Studies on Acoustic Target Strength of Squid

I. Intensity and energy target strengths

I Nyoman ARNAYA*, Noritatsu SANO* and Kohji IIDA*

Abstract

An energy-domain method for measurement of the acoustic target strength of squid was developed and examined in controlled water tank experiments. Simply stated, this has attempted to find a robust and expedient method of acoustic target strength measurement in accordance with the application of an echo integrator.

By the energy-domain method, precise or accurate target strength measurement is possible. The average values for energy target strength are significantly lower than intensity target strength values, and this difference may represent the blocking effect of the bandpass filter or receiving amplifier of the echo sounder on the backscattered signal. However, the linear proportionality of the two-domain has not been established. The reason is that the squared peak-detected echo amplitude or intensity is not linearly proportional to the integrated squared signal or energy. This is caused by the change in the echo waveform with different pulse and wavelengths, and also with the orientation of squid within the sound beam.

Introduction

Squid are among the most difficult animals to biologically assess by any method.¹⁾ However, existing data indicate that they are important in many ecosystems and, in general, are underexploited. Acoustic techniques offer some promise, but only under limited circumstances or restrictive assumptions.

As with many fishes, the major problem in applying acoustic techniques to squid assessment is identification and our lack of knowledge of squid target strength properties. As is well known, the target strength is a pivotal factor for designing fishery echo sounders and sonars and for quantitative and qualitative estimations of fish stocks by acoustic techniques.

Few researchers have worked in this field,²⁻⁵⁾ and exact knowledge has not been well established because of many difficulties, such as the acoustically complex shape of squid, their soft-bodied condition and anatomical composition, unique swimming style (mobility), and lack of a swimbladder.

Therefore, the first aim is to introduce an energy-domain method for measurement of the target strength of squid, and to represent the complexity of orientation, size, species, and ensonifying frequency dependences of squid target strength functions. Simply stated, we have attempted to find a robust and expedient method of squid target strength measurement in accordance with the application of an echo integrator. What should be noted here is that it is energy, or integrated acoustic intensity, and not amplitude or peak-voltage which is the decisive quantity in

* *Laboratory of Instrument Engineering for Fishing, Faculty of Fisheries, Hokkaido University*
(北海道大学水産学部漁業測器学講座)

observing or measuring target strength. Consequently, the measured target strength obtained by this energy-domain method may be considered as energy target strength. To demonstrate the power of the method, the intensity-domain method was also applied, and the results were then compared statistically.

Definition of Intensity and Energy Target Strengths

As an observable process, acoustic backscattering by a discrete body consists of ensonification, echo formation, and echo reception.⁶⁾ The effect of observing finite echoes by intrinsically wideband, frequency-sensitive devices such as echo sounders may be incorporated directly in the theory. According to the filtering analogy as described below and the usual assumption of linearity, the component processes are strictly multiplicative in frequency domain.

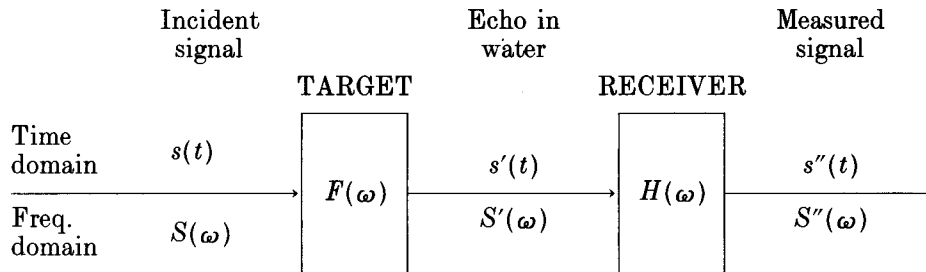

Given the Fourier relationship between signals and their spectra, expressed, respectively, in time t and frequency ω domains, the spectrum $S''(\omega)$ of the received signal $s''(t)$ is related to the spectra $S'(\omega)$ and $S(\omega)$ of the respective signals $s'(t)$ and $s(t)$ by the relation:

$$S''(\omega) = S'(\omega)H(\omega) = S(\omega)F(\omega)H(\omega) \quad (1)$$

where $H(\omega)$ is the frequency transfer function of the receiver, and $F(\omega)$ is the monochromatic scattering amplitude or frequency transfer function of the target.

The target strength TS is usually defined theoretically with respect to the monochromatic scattering amplitude $F(\omega)$ as described above, with the result $TS = 10 \log |F(\omega)|^2$. This is untenable in the case of wideband reception of finite echoes. For this, the basic definition of TS in terms of the backscattering pressure $p(bsc)$ and incident pressure $p(inc)$ must be revised,

$$TS(I) = 10 \log (|p(bsc)|^2 / |p(inc)|^2) \Big|_{R=1 \text{ m}} \quad (2)$$

where R is the measuring distance. According to this conventional definition, $TS(I)$ is determined by intensities, which have meaning only for monochromatic or continuous waves. In the case of finite signals and intrinsically wideband receivers, the definition can be generalized by replacing each intensity by a time integral or energy. In order to maintain the original definition in the limit of a continuous wave, the energy associated with the incident wave is calculated as though it were received, hence processed in the same manner as the echo signal. Thus,

$$|p(bsc)|^2 \longrightarrow \int_0^\infty |SFH|^2 d\omega$$

and

$$|p(inc)|^2 \longrightarrow \int_0^\infty |SH|^2 d\omega$$

The new operational definition of energy target strength is, therefore,

$$TS(E) = 10 \log \left(\int_0^\infty |SFH|^2 d\omega / \int_0^\infty |SH|^2 d\omega \right) \quad (3)$$

Equation (3) shows that the measured $TS(E)$, in general, not only depends on the target (object) and the ensonifying frequency, but also on the measuring system and measuring signal. This means that when we use broad-banded signals and a device for target strength measurements, we have to verify that the results are correct. Through this energy-domain, the possibility of precise or accurate target strength measurement is thus apparent.

Materials and Methods

For the present measurements, the subject specimens were 48 squids including three species, *i.e.*, surume ika (*Todarodes Pacificus*), aka ika (*Ommastrephes bar-*

Table 1. Basic biology of the 48 squid specimens used in measurements.

Squid No.	Species	Dorsal ML (cm)	Body W (g)	Squid No.	Species	Dorsal ML (cm)	Body W (g)
01	Surume	14.8	57	25	Surume	27.0	430
02	"	15.0	60	26	"	27.8	472
03	"	15.4	83	27	"	28.6	560
04	"	15.5	61	28	"	29.2	560
05	"	16.6	90	29	Aka	15.2	103
06	"	17.0	110	30	"	16.2	104
07	"	17.2	92	31	"	16.4	88
08	"	17.2	100	32	"	17.2	133
09	"	18.0	113	33	"	17.4	167
10	"	18.4	175	34	"	17.5	138
11	"	19.0	133	35	"	18.4	176
12	"	19.6	150	36	"	23.0	405
13	"	20.2	172	37	"	23.5	385
14	"	20.6	175	38	"	23.8	377
15	"	22.0	250	39	"	24.2	422
16	"	22.3	263	40	"	26.0	540
17	"	22.4	246	41	"	26.6	527
18	"	22.5	285	42	"	27.5	557
19	"	22.8	260	43	"	28.1	677
20	"	25.0	305	44	"	40.0	2000
21	"	25.0	308	45	"	42.0	2200
22	"	25.0	385	46	"	45.0	2700
23	"	26.0	410	47	"	52.5	3800
24	"	26.4	447	48	Yari	35.0	520

trami), and yari ika (*Loligo bleekeri*). The basic biology (dorsal mantle length and body weight) composition is shown in Table 1. All of the squid specimens were dead squids. Since, however, squids were frozen at capture and thawed out immediately prior to measurement, it was necessary to allow the squids to stabilize in the anechoic water tank. Before ensouffication they were checked for bubbles forming in the body; if present, such bubbles were removed by manipulation of the body to allow the gas to escape. Freshwater temperature during measurements varied from 6.5 to 9°C.

The general arrangement of the test apparatus is shown in Fig. 1. The targets were suspended by monofilament lines in the centre of a water tank of capacity 108 m³ (12-m length × 3-m width × 3-m depth). One set of transducers, JRC-CFT-550 and JRC-CFT-210 of 50 kHz and 200 kHz, respectively, were used both as projector and receiver (collocated source and receiver). Measured directivity patterns are shown in Fig. 2. The length of pulse was 0.5 ms and 0.2 ms for 50 kHz and 200 kHz, respectively. Calibration of the echo sounder (JRC-JFV-216) was performed by means of a 91 mm standard steel ball.

As described above, explicitly there are two basic methods for acquiring target strengths data (see Fig. 3), *i.e.*, intensity domain and energy domain. In the intensity domain, received echo signal is squared and a peak detected, and in the energy domain, the received echo signal is squared and time integrated. In practice,

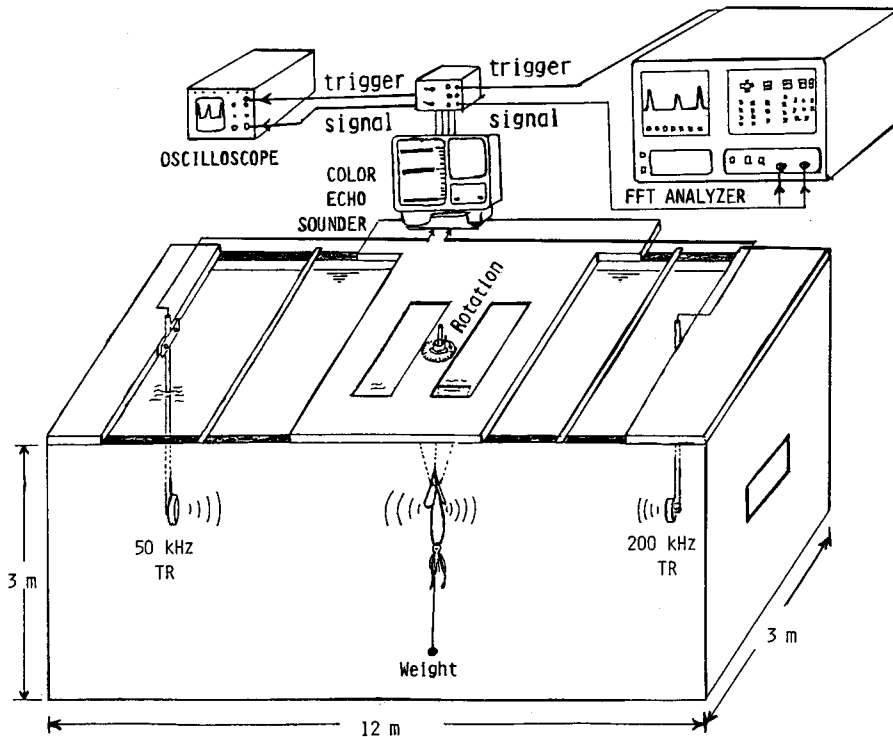
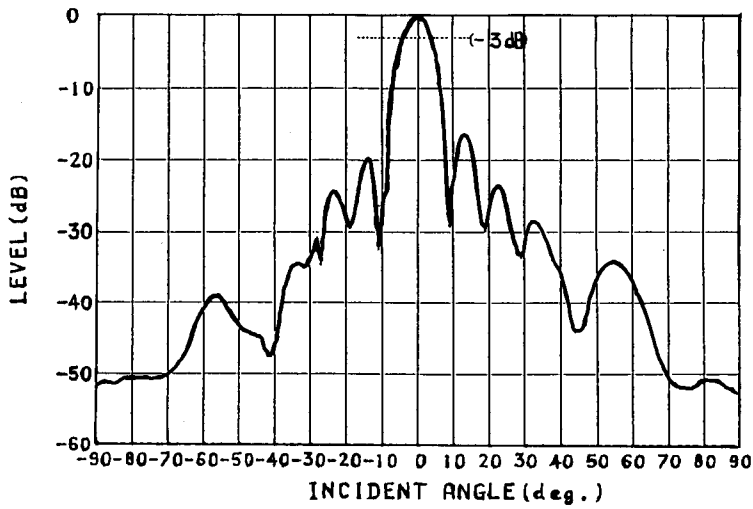
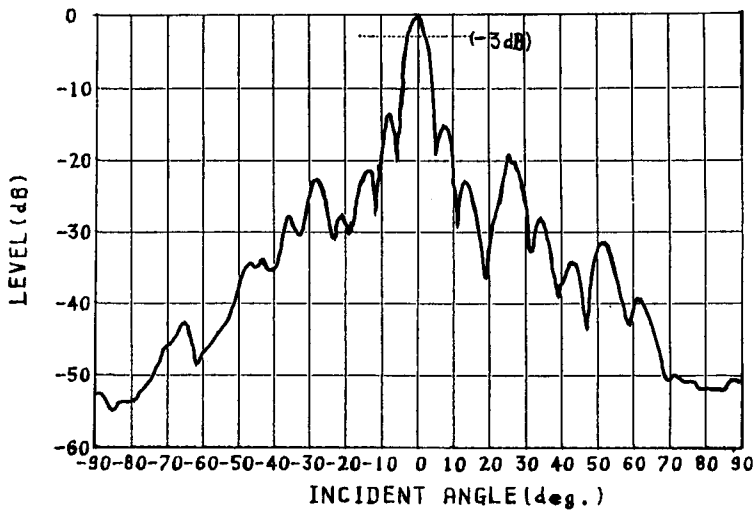

Fig. 1. Block diagram of measuring system.



(A)



(B)

Fig. 2. Directivity pattern of 50 kHz (A) and 200 kHz (B) transducers.

the echo signals received by the echo sounder were processed by a FFT Analyzer (ONO SOKKI CF-920). Input to this FFT Analyzer consisted of echo signals sampled along a display time scale of 8 milliseconds (ms), with sampling interval of 0.0078 ms, averaged (running average) over 16 times. An example of the step-by-step echo signal processing method is shown in Fig 4. It is necessary to remember, however, that the time and frequency domain of echo signal forms a Fourier

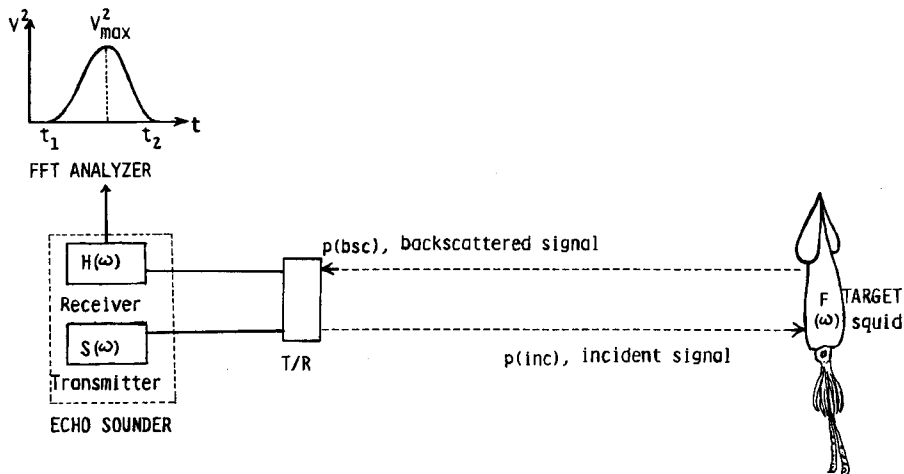

Fig. 3. Concept of intensity and energy target strengths measuring system.

transformation pair which differ only mathematically; the physical information contained in each is the same. Depending on the application, *i.e.*, whether frequency spectra or merely shapes are being considered, either domain may be chosen.⁷⁾

Before performing squid target strength measurements, the reference (standard steel ball) target strength measurements were determined. The target strength of the reference, *i.e.*, $TS_r(I)$ and $TS_r(E)$ for intensity and energy target strengths, respectively, were measured with the assumption that the target is on the acoustic axis and in the farfield of the transducer.

The intensity target strength of squid $TS(I)$ was then calculated by the expression:

$$TS(I) = 10 \log [V^2 \max / V^2_r(\max)] + TS_r(I) \quad (4)$$

where $V^2 \max$ is the peak squared echo envelope voltage of squid, $V^2_r(\max)$ is the peak squared echo envelope voltage of the reference, and $TS_r(I)$ is the target strength of the reference measured by the intensity-domain.

The energy target strength of squid $TS(E)$ was therefore calculated by the equation:

$$TS(E) = 10 \log \left[\int_{t_1}^{t_2} V^2(t) dt / \int_{t_1}^{t_2} V^2_r(t) dt \right] + TS_r(E) \quad (5)$$

where $\int_{t_1}^{t_2} V^2(t) dt$ is the echo energy of squid, $\int_{t_1}^{t_2} V^2_r(t) dt$ is the echo energy of the reference, and $TS_r(E)$ is the target strength of the reference measured by the energy domain. The time integration limits, t_1 and t_2 , were chosen to include the periods when the signals are significantly above noise level (if any).

For comparison of two-target strength, averaging with respect merely on the simple arithmetic method in roll plane with mean roll angle of 0° (dorsal aspect) and spread from mean of $\pm 45^\circ$, were performed. The results were then regressed on squid dorsal mantle length according to the linear regression:

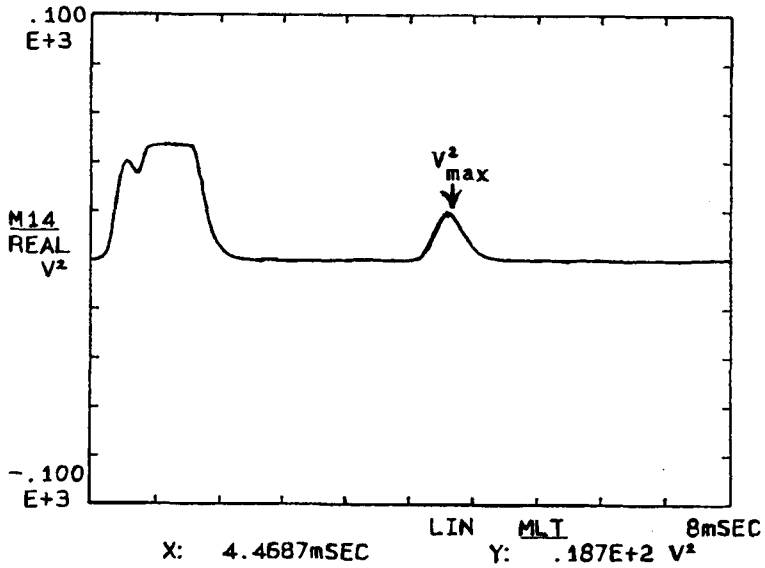

(A)

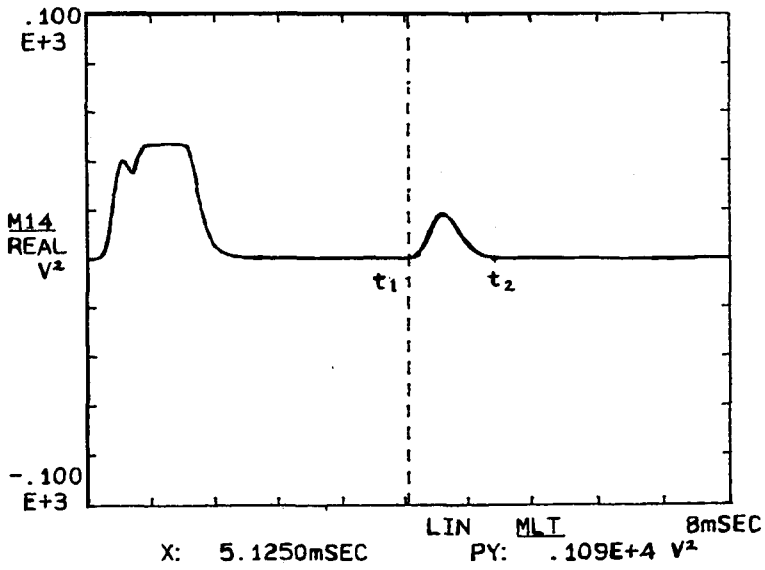

(B)

Fig. 4. Squaring process of echo signal (A) and time integrating process of squared echo signal (B).

$$TS = m \log ML + b \quad (6)$$

where ML is the dorsal mantle length of squid in centimeters, m is the slope of the regression line, and b is the intercept of the regression line on the vertical axis. This regression line also facilitated the systematic comparison of species of squid and ensonifying frequencies.

Results and Discussion

The results of target strength measurement of the reference target (standard steel ball of diameter 91 mm) indicated that of the two methods described, the energy domain method was more accurate than the intensity domain method. This can be observed by comparing the measured values (-31.33 dB and -32.50 dB at 50 kHz for intensity and energy target strength, respectively) with theoretical value (-32.86 dB) calculated by the equation $TS_r = 10 \log (a^2/4)$, where a is the radius of the reference target (assumed to be a perfect and rigid sphere).⁹⁾

Also from these results, the value of energy target strength of the reference target is less than the intensity target strength. This difference may represent the blocking effect of the bandpass filter of frequency transfer function in receiving amplifier of the echo sounder (see Fig. 5) on the backscattered signal. On the other hand, this may indicate the significance of the energy domain method which is considered to the system frequency response.

As shown in Table 1, squids are significantly longer than the length of the sound wave (both for 50 kHz and 200 kHz). Apropos of these relatively high frequencies and the complicated shape and heterogeneous structure of squid, the target strength function, even considered for the roll plane only, is generally complicated. This is illustrated in Fig 6A, which shows the roll-angle dependence of the measured target

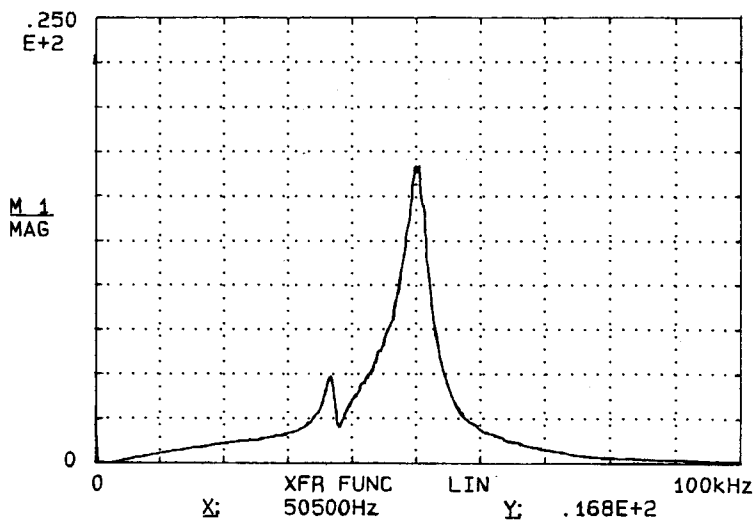
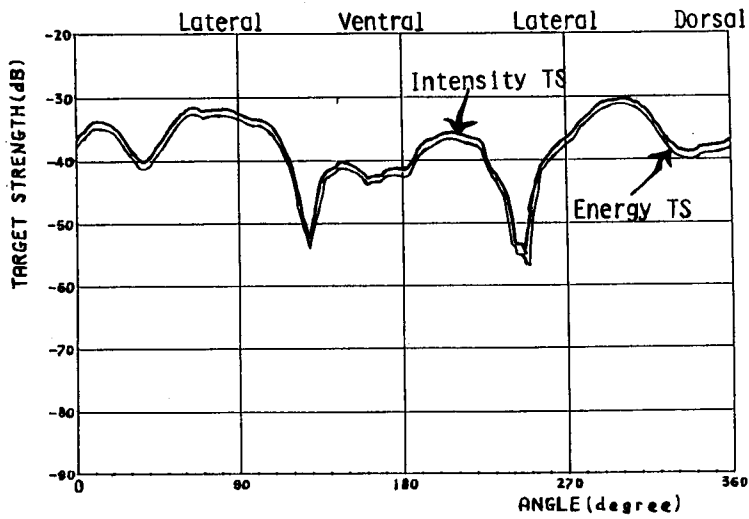
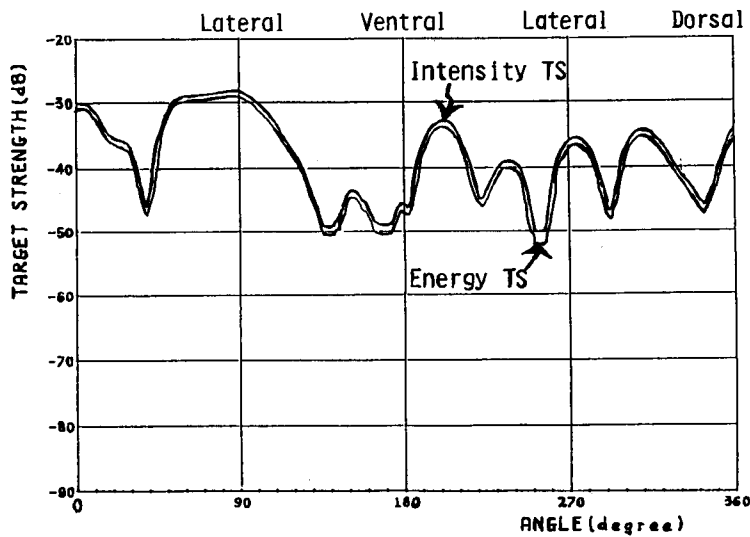

Fig. 5. Measured receiver's frequency transfer function of 50 kHz JRC-CFT-550 transducer.



(A)



(B)

Fig. 6. Linear plot of 15.5 cm (A) and 22.8 (B) surume ika target strength in roll plane at 50 kHz.

strength function of a 15.5 cm squid dorsal mantle length at 50 kHz.

Despite the evident complexity of the effect of orientation on the squid target strength function, systematic dorsal mantle length and ensonifying frequencies dependences can be observed in empirical target strength function. An example of the increasing complexity of the target strength function with squid dorsal mantle length is shown in Fig. 6, a graphical comparison of the target strength function for

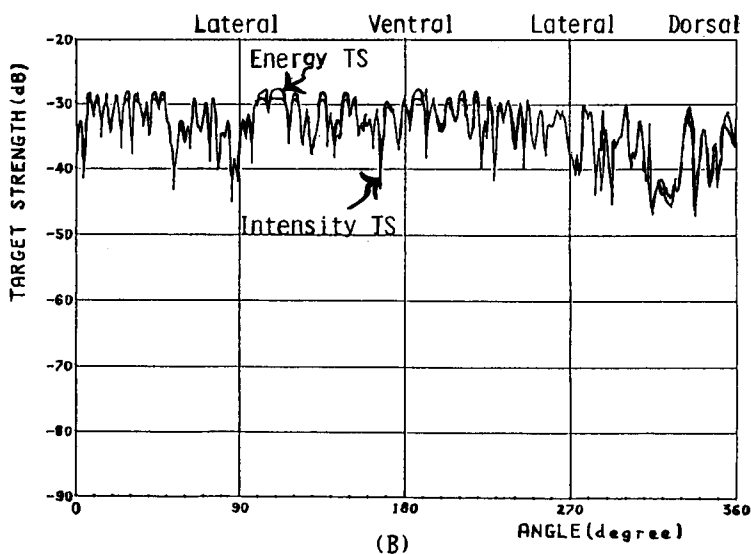
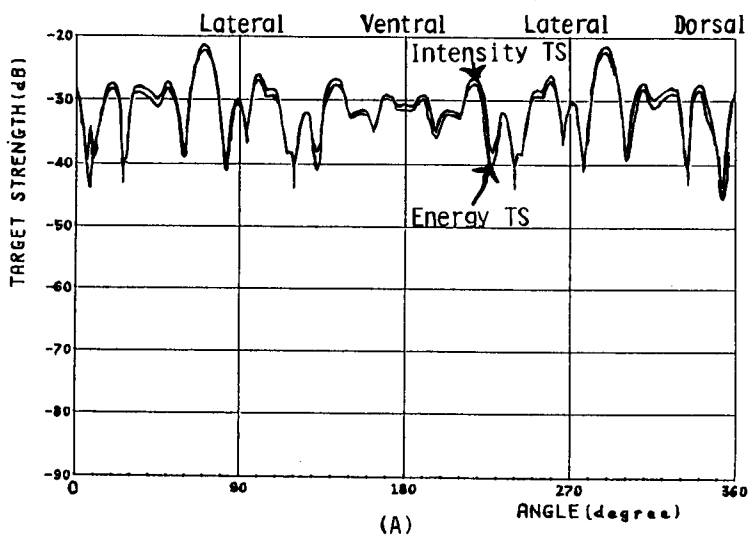

Fig. 7. Linear plot of 45.0 cm aka ika target strength in roll plane at 50 kHz (A) and 200 kHz (B).

two squids with dorsal mantle lengths in the approximate ratio of 1:1.5. The increased complexity of the target strength function of the same squid at 200 kHz is described in Fig. 7. The high fluctuation of target strength values at 200 kHz may be caused by removal of the interference component during process scattering in the water. On the other hand, compared to the reference target, complexity of the

components and shape of different parts of the squid body will significantly affect the composition of the backscattered signals in the process of echo formation.

From Figs. 6 and 7, it is clear that the target strength of squid is a function of aspect, body shape, length, and ensonifying frequency. In addition, the soft-bodied condition of squid caused it to change in form from measurement to measurement in a given position.

As expected, energy target strength values are generally lower than intensity target strength values, but linear proportionality of the domains has not been established. The reason is that the squared peak-detected echo amplitude or intensity is not linearly proportional to the integrated squared signals. This is due to the change in the echo waveform (pulse shape) with different pulse and wavelengths, and also with orientation of the squid within the sound beam, those of the same size, species, and incident signal.

Furthermore, as measurement of target strength is based on comparison with the reference target, which the echo signal has a shape relatively constant for a given frequency and pulse length, change of squid echo waveform will be affected the different of intensity and energy target strength values.

For large squid, especially aka ika, the shape of the echo signal changes according to orientation in the roll plane as shown in Fig. 8. These changes in echo waveform will affect the value of the received echo signal. In any case, energy-

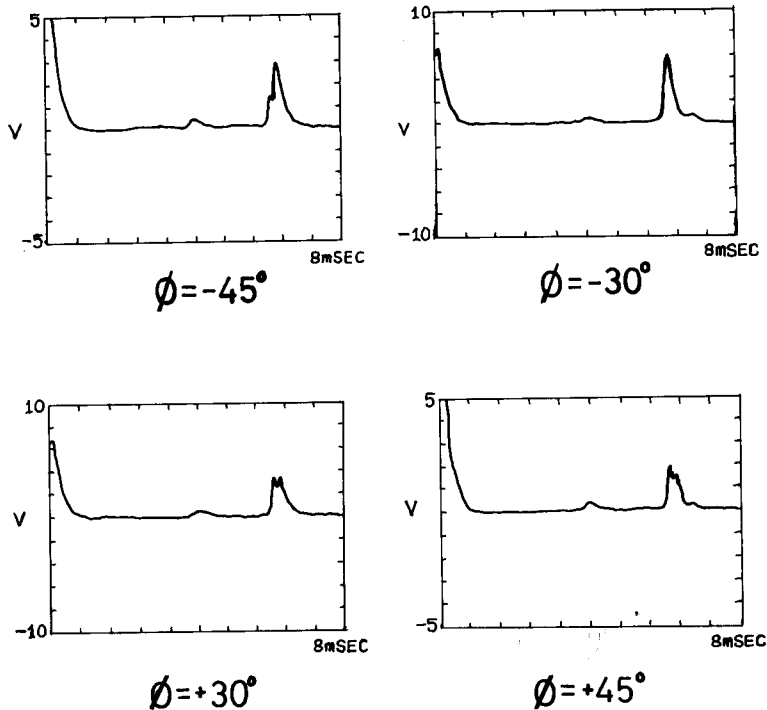

Fig. 8. Examples of the change of echo waveform in roll plane (near dorsal aspect) for 52.5 cm aka ika at 200 kHz.

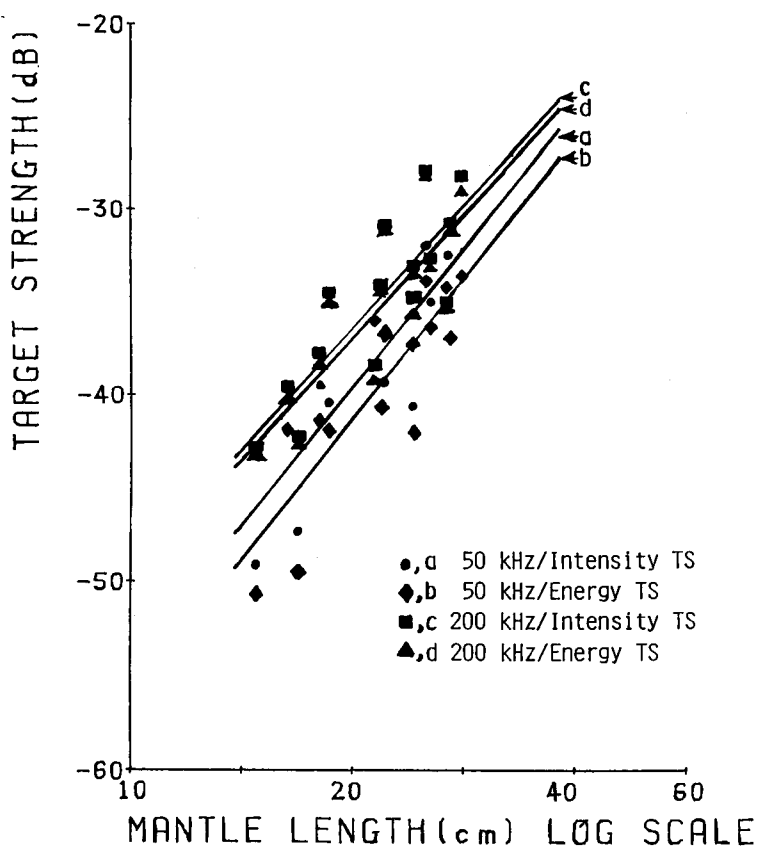

Fig. 9. Scatter diagram and regression of averaged dorsal aspect target strength of surume ika.

a $TS = 47.50 \log ML - 101.90$ ($r = 0.840$)

b $TS = 48.23 \log ML - 104.58$ ($r = 0.850$)

c $TS = 41.98 \log ML - 91.48$ ($r = 0.840$)

d $TS = 42.02 \log ML - 92.05$ ($r = 0.837$)

based measurements are considered more accurate and are preferred if a suitable spectrum analyzer or echo integrator is available. The agreement between the theoretical and experimental values emphasizes the consistency of the operational definition of energy target strength.

Results of regression analysis of averaged dorsal aspect target strength on mantle length of squid (Fig. 9, as an example) indicated that there is a significant difference in averaged dorsal aspect target strength between the two methods (intensity and energy-domain). A significant difference also existed between the two ensonifying frequencies. The effect of these ensonifying frequencies, orientation or behaviour of squid, and other factors on averaged dorsal aspect target strength will be discussed in more detail the next report.

Conclusion

In studies of acoustic techniques in fisheries, a considerable amount of attention has been given to target strength of fish. Few acoustic target strength studies have dealt with soft-bodied animals such as squids. The target strength properties of squid are not precisely known, consequently, many problems in applying acoustic techniques to squid assessment are still unresolved. This first in a series of studies under controlled conditions has attempted to find a robust and expedient method of squid target strength measurement by applying an energy-domain method.

By means of this energy-domain method in target strength measurement we derived the following conclusions :

(1) In work which demands a high degree of precision, such as echo integration, the effect of the frequency transfer function on the received echo signal should not be ignored. Consequently, the definition of acoustic target strength must be generalized by replacing each intensity by energy or time integration of squared echo signal.

(2) By the energy-domain method, precision or accuracy of target strength measurement is thus possible. Generally, the value of energy target strength is significantly lower than intensity target strength values. This difference may represent the blocking effect of the bandpass filter or receiving amplifier of the echo sounder on the backscattered signal.

(3) The linear proportionality of the domains has not been established. This is because the intensity or squared peak-detected echo amplitude is not linearly proportional to the energy or integrated squared signal. This is caused by the change of the echo waveform with different pulse and wavelengths, and also with orientation of squid within the sound beam, those of the same size, species and incident signal.

(4) To gather more complete knowledge of the target strength properties of squid in relation to their species, specific orientation and behaviour, structural body components and physical parameters, body length, and ensonifying frequency, theoretical and experimental studies must be performed. This will be the aim of subsequent studies.

Acknowledgements

The authors gratefully acknowledge to Dr. T. SUZUKI, Emeritus Professor in the same laboratory for his kind encouragement and guidance throughout this study. Special thanks are also due to Ass. Prof. G. KOBAYASHI, now Captain of Hokusei Maru Training Ship of Hokkaido University, who kindly supplied some of the squid samples.

References

- 1) Pearcy, W.P. (ed.) (1983). SCOR symposium on methods of sampling micronekton. *Biol. Ocean.*, 2(2-4), 120-121.
- 2) Matsui, T., Teramoto, Y., and Kaneko, Y. (1972). Target strength of squid. *FAO Fish. Circ.*, 142, 27-29.

- 3) National Research Institute of Fisheries Engineering (1983). Measurement of the target strength of aka ika. 45 p. (In Japanese).
- 4) Vaughan, D.L. (1978). The target strength of individual market squid, *Loligo opalescens*. *Fish. Bull.*, 169, 149-159.
- 5) Jefferts, K., Burczynski, J., and Percy, W.G. (1987). Acoustical assessment of squid (*Loligo opalescens*) off the Central Oregon Coast. *Can. J. Fish. Aquat. Sci.*, 4, 1261-1267.
- 6) Foote, K.G. (1982). Optimising copper spheres for precision calibration of hydroacoustic equipment. *J. Acoust. Soc. Am.*, 71(3), 742-747.
- 7) Ryan, Jr., W.W. (1978). Acoustic reflections from aluminum cylindrical shells immersed in water. *J. Acoust. Soc. Am.*, 64, 1159-1164.
- 8) Urick, R.J. (1983). Principles of underwater sound. Third edition. 423 p. McGraw-Hill Book Co., New York.