



HOKKAIDO UNIVERSITY

Title	STUDIES OF THE HYDROGEN ELECTRODE PROCESS ON LEAD CATHODE AT VERY HIGH ELECTRODE POTENTIALS
Author(s)	MITUYA, Atusi; YAMAZAKI, Tsunehiro
Citation	JOURNAL OF THE RESEARCH INSTITUTE FOR CATALYSIS HOKKAIDO UNIVERSITY, 7(1), 42-51
Issue Date	1959-09
Doc URL	https://hdl.handle.net/2115/24692
Type	departmental bulletin paper
File Information	7(1)_P42-51.pdf



STUDIES OF THE HYDROGEN ELECTRODE PROCESS ON LEAD CATHODE AT VERY HIGH ELECTRODE POTENTIALS

By

Atusi MITUYA and Tsunehiro YAMAZAKI^{*)}

(Received July 26, 1959)

Number of works have been reported on the hydrogen electrode of lead, but they deal exclusively with higher cathodic polarization above 600 mV and, besides, their results disagree with each other as those of HICKLING and SALT¹⁾, BOCKRIS²⁾, and KAVANOV and JOFA³⁾ as shown in Fig. 1. More or less similar situation holds with the works on other metals of hydrogen electrode.

Nevertheless, it is often tried to extrapolate so-called exchange current i_0 at zero polarization, as an important criterion for the mechanism of hydrogen electrode, from cathodic current i observed at high cathodic polarization relying upon the linear relation between $\log i$ and cathodic polarization $-\eta$.

One of the authors⁴⁾ has previously reported his work on a mercury cathode at very low cathodic polarization by preparing and operating the electrolytic cell exclusively in vacuum, and has showed the presence of a break in the linear $\eta-\log i$ relation. This break is just that predicted by the dual theory⁵⁾ indicating that the above drastic extrapolation is of little sense; experiments must be extended to the region of lower cathodic polarization for elucidating the mechanism of hydrogen electrode reaction.

The present authors have conducted the experiments on lead cathode at extremely low cathodic polarization as reported below, by vacuum process as in the previous experiment on mercury cathode⁴⁾.

Experimental

Materials were prepared as follows:

*) A. M. and T. Y.: Department of Chemistry, St. Paul's University (Rikkyo Daigaku), Ikebukuro, Tokyo.

The Hydrogen Electrode Process on Lead Cathode

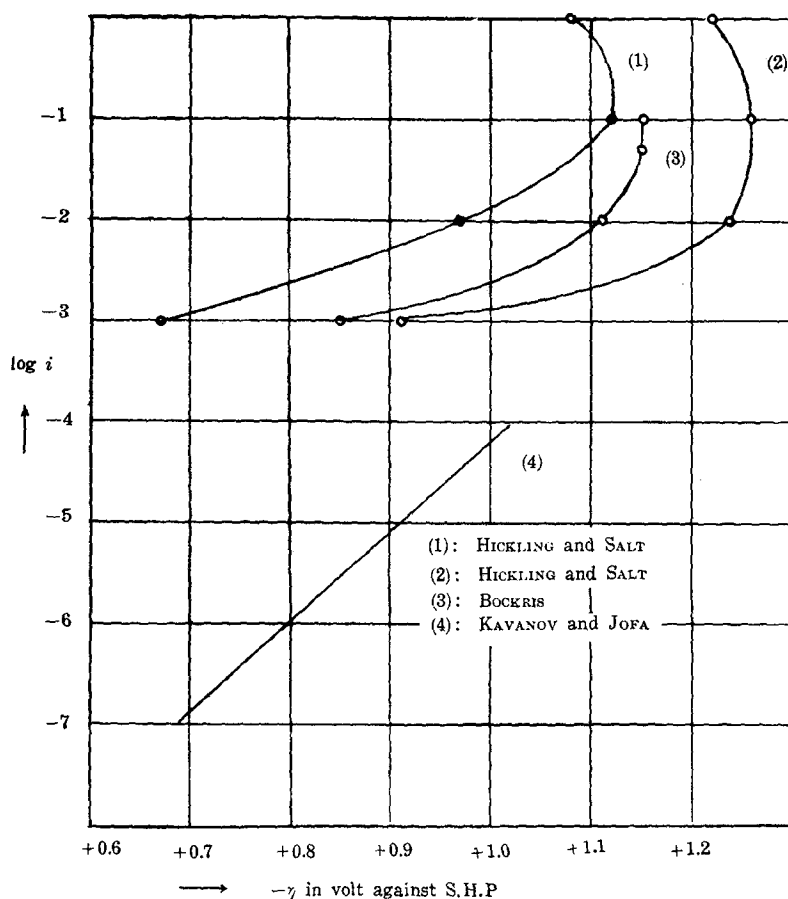

Fig. 1. Hydrogen overvoltage on lead cathode, observed by several workers.

(1) Pb-cathode: Lead metal of purity 99.996%, guaranteed by the Mitui Metal and Mining Co., was melted at 400°C in compartment A in Fig. 2 under high vacuum (below 10^{-5} mmHg). Line S, was now sealed off and hydrogen gas, purified by passing it through palladium thimble, was slowly introduced through a breakable joint in the Figure to push the melt from A to C, through the trap B where the oxides in the bulk of the lead metal was separated. A glass tube D with a platinum contact sealed in a glass rod was thus covered with the pure molten lead by its lower end as shown in the Figure, and hydrogen gas filled now the combined spaces of A, B and C up to the greeseless tap T. As the lead cooled and solidified, it plucked the inner tube

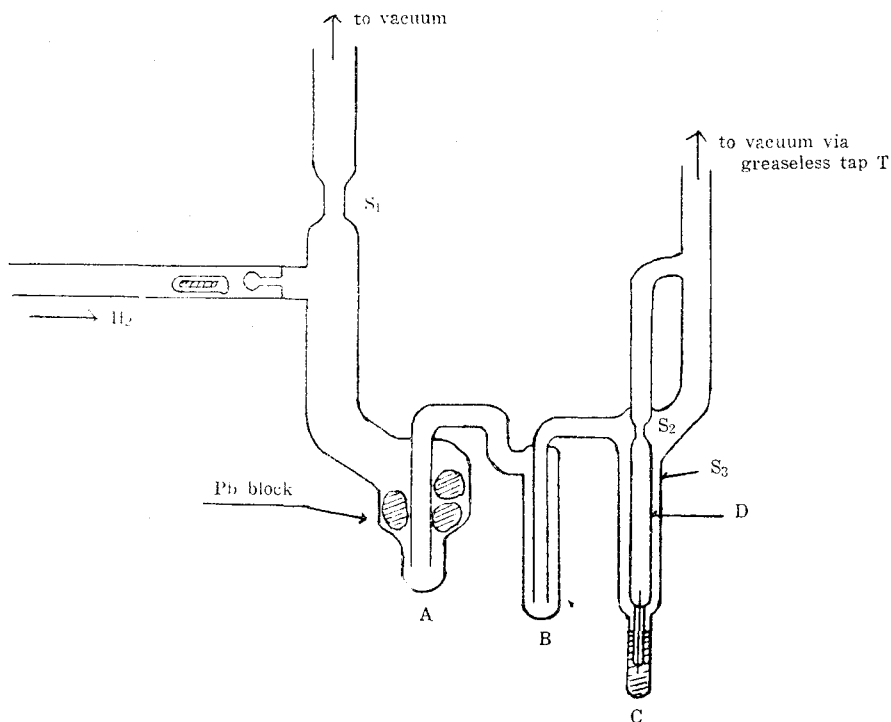

Fig. 2. Scheme of preparation of cathode materials.

at S_2 , where a scratch is preliminarily filed, keeping the geometry of the lead cathode and the platinum seal as shown in the Figure.

The outer tube was now cut off at S_3 and glass around the lead electrode was removed by hydrogen fluoride solution in air. The lead metal thus obtained had a color and brilliant shine like a polished silver and firmly fixed to the platinum contact. The cathode thus prepared was now worked out to make Cell-I, as shown in Fig. 3, and subjected to cathodic purification of the lead electrode in electrolytically purified 0.1N-HCl solution in F_2^b (cf. (III)) under vacuum.

The cathodic purification was conducted similarly as in the previous work^(*) using redistilled water in F_3 for wash and F_4 for drain. After these procedures, the constrictions S_4 , S_5 and S_6 were sealed off, and a proper amount of electrolytically purified 0.1N-HCl solution in F_2^a (cf. (III)) was introduced by a careful distillation through the breakable joint a, and then the purified hydrogen was introduced through b, just

^{*}) Cf. Ref. 4, § 1, (1).

The Hydrogen Electrode Process on Lead Cathode

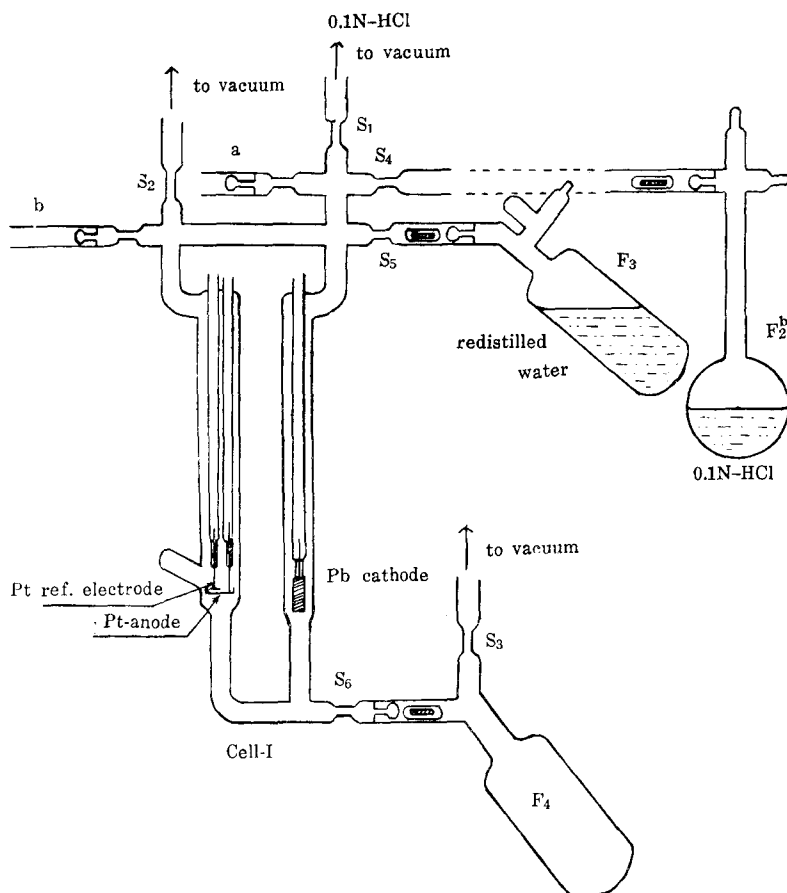

Fig. 3. Diagram of the pre-electrolytic purification apparatus for the electrodes in electrolytically purified.

to put the gas-liquid interface at the platinum reference electrode in order to facilitate it to work as a reversible hydrogen electrode. The cell was completed by sealing off the constrictions a and b. Its complete make-up is shown in Fig. 4. The apparent area of the cathode was 5.8 cm^2 and the hydrogen gas pressure was 560 mmHg at 19°C .

(II) Pt-electrodes: Because of very large apparent area of the cathode, a platinum anode of the form of a shallow dish as shown in Figs. 3 and 4 was used to prevent any appreciable polarization. The platinum reference electrode was a platinized platinum plate, which was placed close at the bottom of the dish in order to prevent any granule of platinum black from coming down into the solution. These platinum

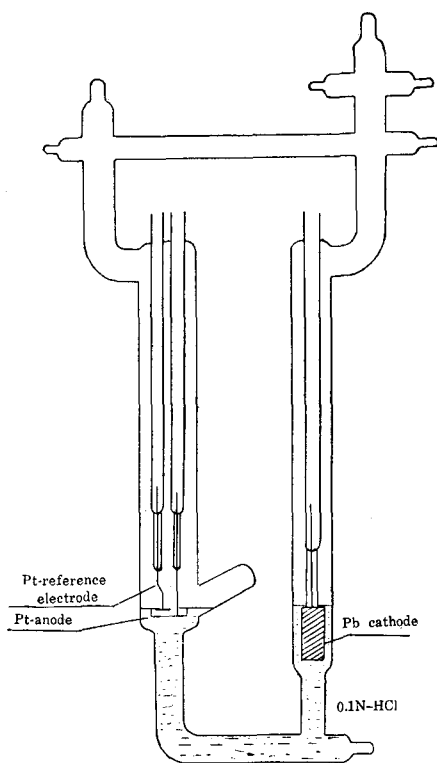

Fig. 4. Electrolytic cell.

electrodes were platinized in this dish to cover the whole surface of the plate and the inner surface of the dish only. The methods of the purification of the platinum electrodes were the same as those described in the previous report⁴⁾.

(III) H_2 gas and 0.1N-HCl solution: Cylinder hydrogen was purified by passing it through a palladium thimble, a liquid oxygen trap, being kept afterwards from contacting any greased tap or joint.

The pre-electrolytic purification of 0.1N-HCl solution was carried out in Cell-II under vacuum, as shown in Fig. 5. Solution in flask F_1 was introduced into Cell-II by vacuum distillation, and the electrolysis was continued for 5 days, applying a terminal voltage of 0.4 V between platinum anode and lead cathode. After the electrolysis, the solution was introduced into evacuated flask F_2^a and F_2^b via S_3 , breaking the joint by an impact. The amounts of solution in F_2^a and F_2^b were so adjusted that they just touched the surface of the platinum reference

The Hydrogen Electrode Process on Lead Cathode

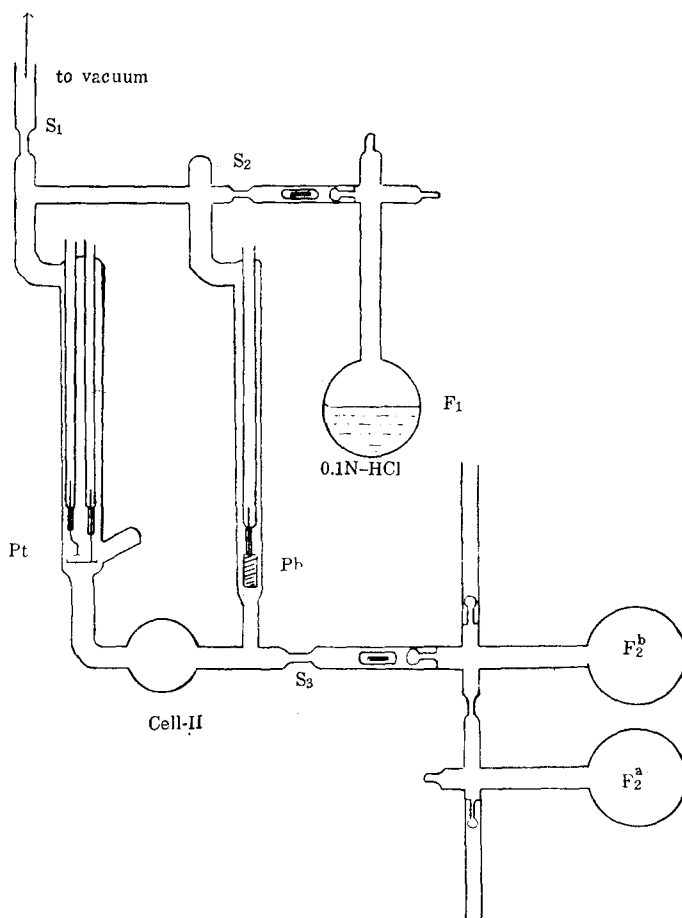

Fig. 5. Diagram of the pre-electrolytic purification apparatus for 0.1 N-HCl.

electrode when introduced into Cell-I for completing the cell as described in (I) or into Cell-II for pre-electrolysis respectively.

The measurement of the current density at each fixed polarization of the lead cathode was conducted as follows:

When the cathode was polarized at a constant cathodic polarization after being left unpolarized, the current i decreased with progress of time to tend asymptotically to a definite value particular to the applied polarization η . Whenever the cathodic polarization was increased (decreased) from a constant value at which an asymptotic current was approached as above, the current increased (decreased) first instan-

taneously and then slowly decreased (increased) to tend to an asymptotic value higher (lower) than the foregoing one. The asymptotic current at any definite polarization was almost reproducible as in the case of mercury⁴⁾. The time required for approaching the asymptotic current to a certain extent varied from 20 to 300 hrs according as the cathodic polarization was higher or lower. It was concluded from these experimental facts similarly as in the previous case⁴⁾ that the asymptotic value gives the current of genuine hydrogen electrode reaction at the appropriate constant cathodic polarization, where the ionization of metal attains partially equilibrium.

The polarization of the anode referred to the reference electrode was completely immeasurable for the asymptotic current density below 2×10^{-6} amp. cm⁻². Results of measurements at such experimental condition were only adopted as sound and shown in Fig. 6, since then any measurable potential gradient in the solution may be absent.

Result and Discussion

Fig. 6 shows the observed η - $\log i$ relation^{*)}, where annexed numbers to points denote their order of the measurements. Since i at a constant polarization should approach the asymptotic value from upwards or downwards according as the constant cathodic polarization is raised or lowered from the foregoing constant one, the points in Fig. 6 consistently determines the η - $\log i$ curve as drawn in the figure, which is reliable at least down to point 6.

We note now that the unidirectional backward current \bar{i} is practically ignorable compared with the unidirectional forward current \bar{i} of the hydrogen electrode reaction

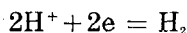

in the region of the present measurement, according to the equation $i = \bar{i} \left(1 - \exp \frac{2F\eta}{\nu RT} \right)^{6/7}$, whether the stoichiometric number ν of the rate-determining step be 1 or 2. It follows that Fig. 6 practically presents η - $\log \bar{i}$ curve and moreover that the latter is by no means linear.

*) This value may be referred to the standard hydrogen electrode which is calculated by adding $\frac{RT}{2F} \cdot \log \left(\frac{P}{760} \cdot \frac{1}{C} \right)$ to the directly observed value referred to the reversible hydrogen electrode in the cell, where P is the hydrogen pressure and C is the activity of the H⁺ ions in the solution.

The Hydrogen Electrode Process on Lead Cathode

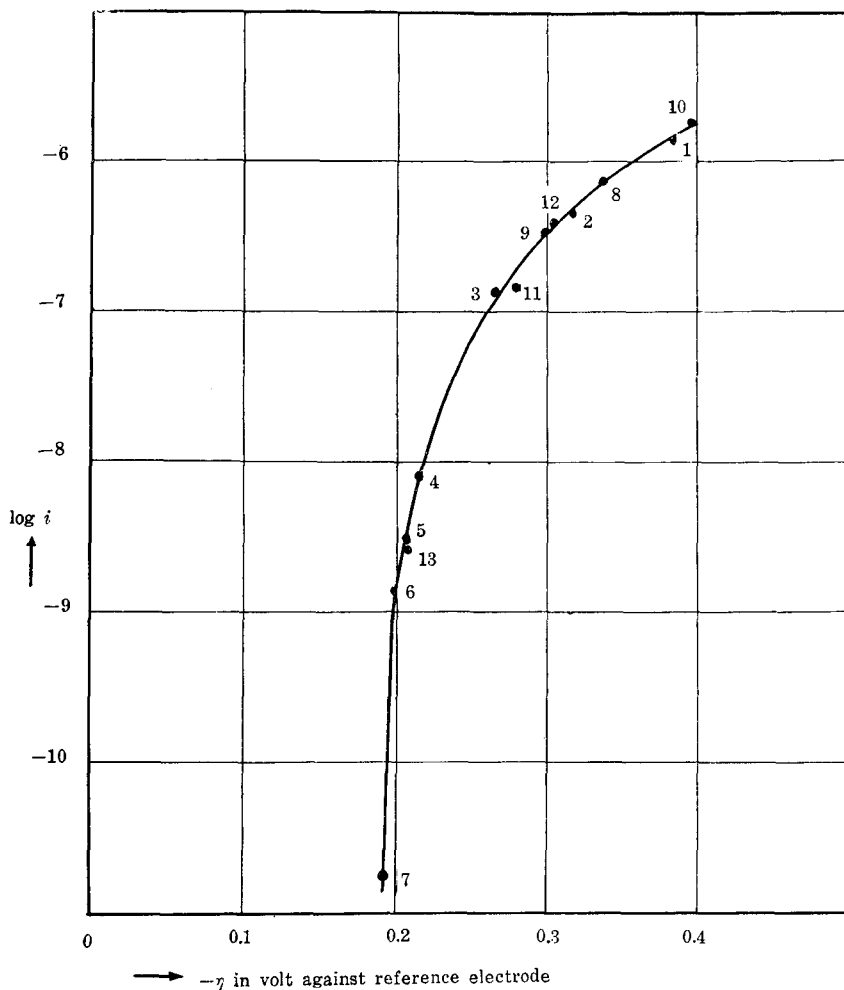

Fig. 6. The η - $\log i$ relationship of lead hydrogen electrode.

The usual linear extrapolation of i_0 from measurements of i at higher cathodic polarization is in consequence of little sense.

It was found that at zero current the potential of the cathode rose slowly up to -0.186 mV within 24 hrs, which kept perceptibly constant for 400 hrs as observed after the series of measurements shown in Fig. 6 in contrast with in the case of hydrogen electrode of mercury, when the cathode potential attained practically to that of reversible hydrogen electrode at zero current. This result could be understood on the ground of the observed rapid decrease of i with decreasing

cathodic polarization as follows. The metal ion concentration at the equilibrium of the ionization of the metal decreases with increasing cathodic polarization. The concentration is hence reduced during the series of the measurement to the value corresponding to the cathodic polarization greater than *ca.* 200 mV. The metal electrode should now be ionized a good deal in order to attain the equilibrium concentration at the reversible hydrogen electrode potential. The positive electricity required for the metal ionization must, however, be supplied by the progress of the hydrogen electrode reaction. But since the latter is extremely slow at lower cathodic polarization, the metal ionization is practically checked as observed. It might be pointed out that the observed extremely slow hydrogen electrode reaction at lower cathodic polarization favours the inhibition of self-discharge of lead accumulators.

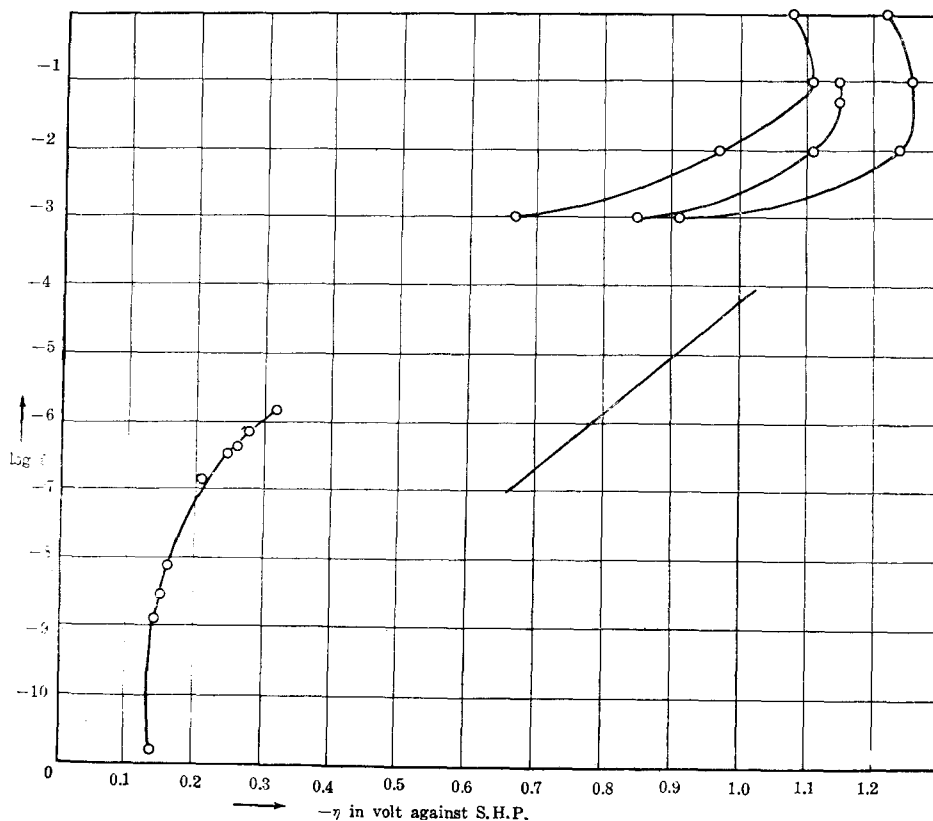

Fig. 7. Comparison of the present η - $\log i$ relation with earlier results.

Fig. 7 compares the present results with earlier ones mentioned above¹⁾²⁾³⁾. No description is found in these earlier works except in that of KAVANOV and JOFA³⁾ about the measurement of the reference electrode for measuring the cathodic polarization.

Summary

Cathodic current i of the hydrogen electrode process on lead cathode was observed over the range of cathodic polarization from 0.18 to 0.39 volt by vacuum operation. The $\log i$ was found not linear function of η and to decrease with increase of η more rapidly at higher η just as in the case of mercury cathode (Ref. 4). Linear extrapolation of $\log i$ to $\eta=0$ for the exchange current i_0 from higher cathodic polarization is in consequence quite impracticable.

Acknowledgement

The authors express their deepest thanks to Prof. J. HORIUTI of Hokkaido Univ. for his encouragement and kind advice.

References

- 1) A. HICKLING and F. W. SALT, *Trans. Faraday Soc.* **36**, 1226 (1940).
- 2) J. O'M. BOCKRIS, *Trans. Faraday Soc.* **43**, 417 (1947).
- 3) B. KAVANOV and Z. A. JOFA, *Acta Physicochim. U.R.S.S.* **10**, 617 (1939).
- 4) A. MITUYA, *J. Res. Inst. Catalysis, Hokkaido Univ.* **4**, 228 (1957).
- 5) J. HORIUTI, T. KEI and K. HIROTA, *J. Res. Inst. Catalysis, Hokkaido Univ.* **2**, 1 (1951).
- 6) J. HORIUTI and M. IKUSHIMA, *Proc. Imp. Acad. Tokyo* **15**, 39 (1939).
- 7) J. HORIUTI, *J. Res. Inst. Catalysis Hokkaido Univ.* **1**, 8 (1948).