



# HOKKAIDO UNIVERSITY

Title	SEPARATION OF PARAHYDROGEN, ORTHOHYDROGEN, HYDROGEN DEUTERIDE, ORTHODEUTERIUM AND PARADEUTERIUM BY GAS ADSORPTION CHROMATOGRAPHY
Author(s)	KWAN, Takao
Citation	JOURNAL OF THE RESEARCH INSTITUTE FOR CATALYSIS HOKKAIDO UNIVERSITY, 8(1), 18-28
Issue Date	1960-07
Doc URL	<a href="https://hdl.handle.net/2115/24714">https://hdl.handle.net/2115/24714</a>
Type	departmental bulletin paper
File Information	8(1)_P18-28.pdf



# SEPARATION OF PARAHYDROGEN, ORTHOHYDROGEN, HYDROGEN DEUTERIDE, ORTHODEUTERIUM AND PARADEUTERIUM BY GAS ADSORPTION CHROMATOGRAPHY

By

Takao KWAN<sup>\*</sup>)

(Received February 18, 1960)

Gas chromatographic separation of HD, ortho-D<sub>2</sub> and para-D<sub>2</sub> was demonstrated at liquid nitrogen temperature by extending the previous method [Bull. Chem. Soc. Japan, **31**, 771 (1958)], *i.e.* by using Linde molecular sieve as column packing and hydrogen as carrier gas. Separation of para-H<sub>2</sub> and ortho-H<sub>2</sub> was also performed by a similar technique *i.e.* by using helium as carrier gas. Isolation and analysis of these hydrogen isotopes and isomers by gas adsorption chromatography were reviewed and discussed.

## Introduction

Partial separation of different molecular species of hydrogen isotopes was first demonstrated by TAYLOR and his associates<sup>1)</sup> in 1933 during the desorption of the mixture from the surface of charcoal kept at liquid air temperature. The isotopic effect revealed in the low temperature adsorption was not reinvestigated basically nor utilized for the enrichment of deuterium over the following two decades. However, the work relating to this and that dealing with the selective adsorption of ortho and parahydrogen isomers are seemingly active indeed in recent years.

The low temperature adsorption of hydrogen and deuterium was summarized<sup>2)</sup> on a number of adsorbents, the adsorption heat being 80–600 cal/mole greater for deuterium than for hydrogen in compatible with TAYLOR's observation. The work of this laboratory<sup>3)</sup> showed that the separation factor for the adsorption of hydrogen isotopes as defined by

$$f = \frac{n_g/n_a}{n'_g/n'_a}$$

was 2.3 for H<sub>2</sub> and D<sub>2</sub> and 1.6 for H<sub>2</sub> and HD at 78.4°K where  $n_g$ ,  $n_a$ ,  $n'_g$  and  $n'_a$  are the concentration of light and heavy component in the gas and adsorbed phase at equilibrium respectively. Linde molecular sieve was used as the adsorbent in either case, and the separation factor was interpreted as due

<sup>\*</sup>) Research Institute for Catalysis and Chemistry Department, Hokkaido University, Sapporo, Japan.

largely to the difference of zero-point energy, 150 cal/mole between H<sub>2</sub>-adsorbent and D<sub>2</sub>-adsorbent bond and 80 cal/mole between the corresponding bonds for H<sub>2</sub> and HD.

The high temperature van der Waals adsorption of hydrogen and deuterium was investigated very recently by FREEMAN<sup>15)</sup> with particular interest to the effect of negative discrete energy levels in the potential energy well for gas-surface interaction. Besides many interesting conclusions arrived at, Freeman discussed the separation of the hydrogen isotopes by the technique of gas adsorption chromatography. In general, the large separation factor of two gases in the adsorption may readily lead to their complete separation when gas adsorption chromatographic technique is applied, since the latter is just a repetition of adsorption and desorption. Thus, we were able to separate HD and D<sub>2</sub> on this basis<sup>4)</sup>. A new method was then proposed to analyze hydrogen isotopes<sup>5)</sup> and chromatographic concentration of deuterium<sup>6)</sup> or the preparation of isotopically pure light hydrogen<sup>7)</sup> proved to be powerful and convenient at least for laboratory purpose.

Theoretically the separation factor may become greater, the lower the temperature. Thus, WHITE and HAUBACH<sup>8)</sup> were able to obtain deuterium of very high concentration at 20.4 K by a desorption technique using alumina as adsorbent.

On the other hand, the adsorption behavior of para- and orthohydrogen is little known except that by SANDLER<sup>9)</sup> who found that orthohydrogen is more strongly adsorbed than parahydrogen when physically adsorbed on rutile or on charcoal. The separation factor, accordingly, was 1.6 at -183°C, the value of which being interpreted as due to the difference of the rotational energy levels which these isomers occupy in both gaseous and adsorbed states. In view of the large separation factor again one may find the possibility for the complete separation of these isomers by means of gas adsorption chromatography.

This has been carried out by MOORE and WARD<sup>10)</sup>, *i.e.* para- and orthohydrogen were completely separated in the elution chromatogram when activated alumina was used as column packing and kept at liquid nitrogen temperature with helium as carrier gas<sup>\*</sup>). The separation of ortho- and paradeuterium was, however, incomplete and moreover HD, when present in the hydrogen sample, was eluted only slightly slow in the chromatogram as compared with orthohydrogen.

Almost at the same time a three-stage adsorption-desorption of normal hydrogen was successfully applied by CUNNINGHAM *et al.*<sup>11)</sup> to the isolation of

\* ) Special device was made by these authors to amplify signals by means of a combustion tube connected before the thermal conductivity gauge.

orthohydrogen on alumina kept at 20.4°K. A similar technique was found useful, by these workers, to concentrate paradeuterium. In view of the analytical, preparative and fundamental importance involved in the separation of hydrogen isotopes and isomers, it seems pertinent to investigate further the characteristics of molecular sieve—the adsorbent which we have been so far interested in—for the gas chromatographic separation of these molecular species.

### Experimental

Shimadzu Gas Chromatograph GC-1A No. 58035 was used for the purpose. The detection of gas sample was made by the thermal conductivity gauge fitted to the instrument. The detector contained coiled tungsten filaments. No special device was made to amplify signals, *e.g.* by using a combustion tube before the gauge or by means of Shimadzu d.c. amplifier. The stainless steel column of U shape equipped with this instrument was not used. Instead a long copper tube having 0.4 cm inside diameter was used in a coiled form so that it could be immersed in a Dewar flask. The sample tube of the apparatus was not designed for evacuating purpose. Therefore a conventional gas sampling system,

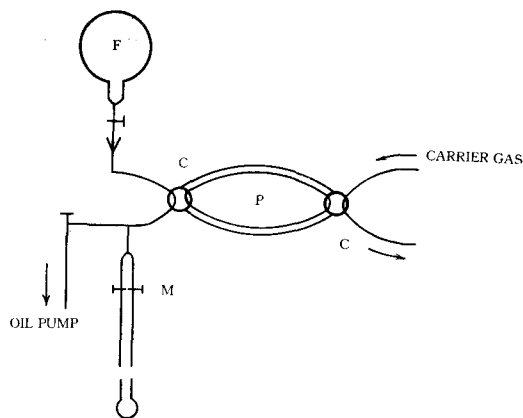

**Fig. 1.** Arrangement for sampling hydrogen gas.

P. Circular pippete    M. Mercury manometer  
C. Four-way cock    F. Sample flask

as shown in Fig. 1, was constructed and fitted to vacuum line as well as to the path of carrier gas in series (cf. Photo. 1).

Hydrogen sample was introduced from the flask F into the circular gas pippete P (24.5 cc), evacuated beforehand to  $10^{-3}$  mm Hg, its pressure being measured by mercury manometer M. This known amount of sample was then allowed to flow into the stream of carrier gas by means of the four-way cock

*Separation of Parahydrogen, Orthohydrogen by Gas Adsorption Chromatography*

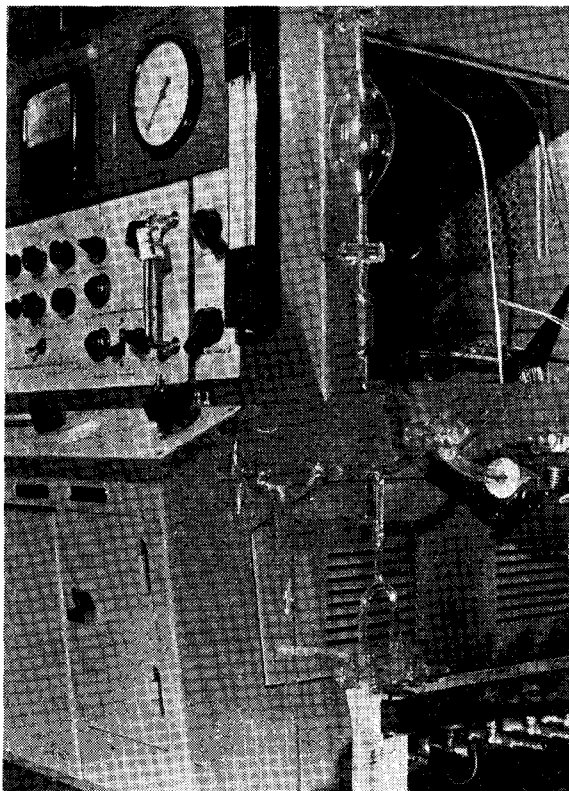

**Photo. 1.** A part of gas chromatographic apparatus and arrangement for sampling hydrogen gas (left).

C. The flow rate of the carrier gas was measured by a soap film meter.

Molecular sieve Type 13 X (Linde, Tonawanda, N. Y.) ground to 30 to 60 meshes was used as column packing. The adsorptivity of this adsorbent was considerably dependent on the content of water. Thus, if highly dehydrated material was used as column packing, hydrogen sample was held so strongly on the packing cooled to  $-195^{\circ}\text{C}$  that it never came out of the column within the time of patience. To shorten the retention times, activation at lower temperature or even no pretreatment was needed. On the other hand, the molecular sieve in the absence of activation inevitably showed a poor column efficiency. Consequently proper pretreatment was needed for obtaining elution chromatograms of good separation within short retention times.

Commercial cylinder hydrogen, purified by passage through a cooled trap containing molecular sieve, was used as carrier gas. To obtain ortho-para

shifted hydrogen sample, normal hydrogen was allowed to contact active charcoal, supplied by Kanto Kagaku Co. Tokyo, at liquid nitrogen temperature for several hours. The equilibration was not checked however. Deuterium (99.5%) purchased from Oxygen Co. San Francisco was mixed with ordinary hydrogen in a ratio of 2 : 1 and completely equilibrated<sup>5)</sup> on platinum-alumina catalyst at 300°C. The mole fraction of H<sub>2</sub>, HD and D<sub>2</sub> of this equilibrium mixture was calculated to be 0.06, 0.34 and 0.60 respectively.

### Results and Discussion

As mentioned already, the activation of molecular sieve above 300°C is not favourable, when helium is used as carrier gas, to give quick emergence of hydrogen isotopes on the chromatogram. The use of hydrogen through such molecular sieve column, on the other hand, gave rise to two peaks<sup>4)</sup> corresponding to HD and D<sub>2</sub> within short retention times, although H<sub>2</sub> peak was of course masked in the chromatogram. Since the column efficiency for the separation of HD and D<sub>2</sub> was found slightly better for 13 X than for 5 A, the 13 X was chosen as column packing in the present investigation.

No activation process was found to be necessary for obtaining any hydrogen peak in the elution chromatogram when helium was used as carrier gas. Coiled copper tubing of 2 meters long filled with 30 to 60 meshes molecular sieve 13 X gave apparent separation of normal hydrogen sample into two components. Such an elution chromatogram is shown in Fig. 2 (a).

To give assignments for the two peaks, at least one further investigation would be required with the sample of ortho-para shifted hydrogen.

An attempt was made first to see if ortho-para conversion could occur while normal hydrogen sample passes through a short column filled with active charcoal. The charcoal column was connected to the inlet of the molecular-sieve column, either being immersed in liquid nitrogen bath. Should the ortho-para conversion be quick enough on the charcoal column while it is absent or extremely slow on the molecular sieve column, the peak corresponding para-hydrogen is expected to grow while that of orthohydrogen will be lowered. The experimental result was however negative, suggesting that ortho-para conversion is negligible during the passage through the charcoal column.

Fig. 2 (b) shows the chromatogram of the hydrogen sample that was in contact with active charcoal at liquid nitrogen temperature for several hours. As shown there, the first peak grew to a slight extent while the second lowered. Therefore, it follows that the first peak is para- and the second orthohydrogen. This order of emergence is in agreement with that obtained by MOORE and

*Separation of Parahydrogen, Orthohydrogen by Gas Adsorption Chromatography*

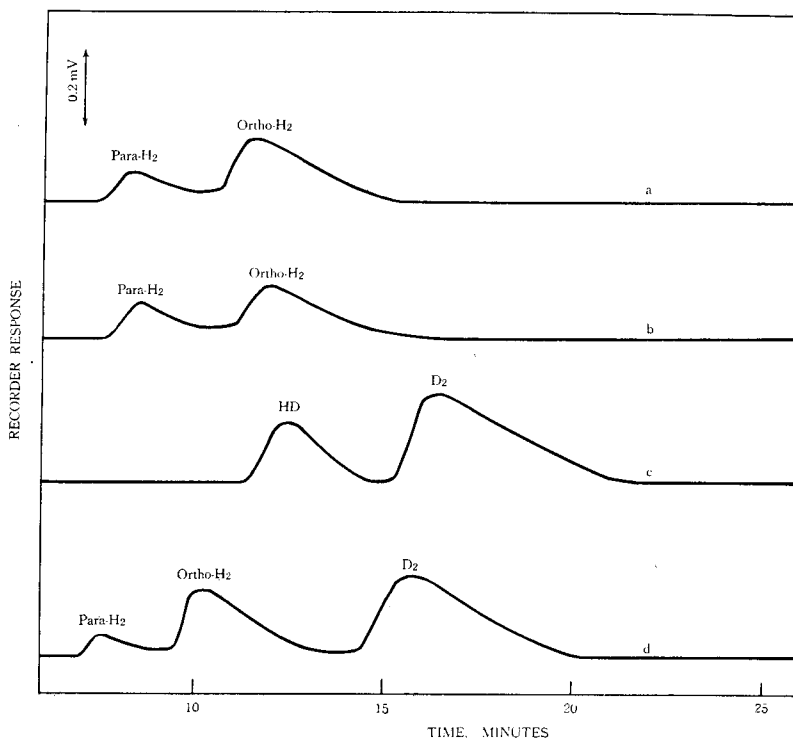

**Fig. 2.** Chromatograms for hydrogen isomers and isotopes.

Carrier gas; Helium

Flow rate; *ca.* 400 ml/min.

Column; Coiled copper tubing of 2 meter long and 0.4 cm inside diameter.

Column packing; Molecular sieve 13x 30-60 meshes.

Column temperature;  $-195^{\circ}\text{C}$ .

Inlet pressure; 0.6-0.7 kg/cm<sup>2</sup>.

Chart speed; 10 mm/min.

Span; 2 mV. Bridge current; 230 mA.

(a) Normal hydrogen 19.3 cc STP.

(b) Para-shifted hydrogen 19.3 cc STP.

(c) H<sub>2</sub>+HD+D<sub>2</sub> (0.06 : 0.34 : 0.60) 11.3 cc STP.

(d) H<sub>2</sub>+D<sub>2</sub> (3 : 1) 23.8 cc STP.

Flow rate of He; 500 ml/min.

Span; 2 mV.

Bridge current; 220 mA.

WARD<sup>10)</sup> on alumina column and acceptable in the light of the finding by SANDLER<sup>9)</sup> that parahydrogen is more weakly adsorbed than orthohydrogen.

If it is assumed that the peak height of a component is a direct measure

of the amount of that component present in the mixture, and that the chromatogram (a) for normal hydrogen is consisted of 1 part parahydrogen and 3 parts orthohydrogen, the chromatogram (b) indicates that the hydrogen sample is consisted of 35% parahydrogen and 65% orthohydrogen. The mole fraction of hydrogen isomers in (b) is hence far from equilibrium<sup>\*)</sup>. This result might show that the equilibration is still incomplete under the prolonged contact with charcoal. However, ortho-para hydrogen conversion may not probably be absent on the molecular sieve because the relative height of the two peaks was not independent on the column length and on the flow rate of the carrier gas.

Fig. 2 (c) shows the chromatogram of a mixture of hydrogen isotopes (0.06 H<sub>2</sub>, 0.34 HD and 0.60 D<sub>2</sub>). Apparently only two peaks were obtained. The sample volume was 11.3 cc STP<sup>\*\*)</sup> in which the amount of H<sub>2</sub> was calculated to be 0.67 cc. STP. Parahydrogen and orthohydrogen involved in this sample may give rise to peak heights ranging from 0.2 to 0.4 mm under the condition used. The observed peaks are too large to account for these isomers. The investigation of the chromatogram of pure D<sub>2</sub> proved that the second peak was due to D<sub>2</sub>. Thus, the two peaks obtained may be assigned to HD and D<sub>2</sub> respectively. In Fig. 2 (d) is shown the chromatogram of a mixture of H<sub>2</sub> and D<sub>2</sub> (3 : 1) which gave, as expectedly, three peaks corresponding to para-H<sub>2</sub>, ortho-H<sub>2</sub> and deuterium.

Since, however, HD is eluted only slightly slow as compared with orthohydrogen as can be seen in Fig. 2 (a), (b), (c), and (d) the overlapping of the two peaks may be expected to occur for these molecular species.

Fig. 2 shows further that the chromatographic separation of ortho- and paradeuterium is more difficult than that of para- and orthohydrogen. The situation would probably be ascribed, in principle, to closer rotational energy levels of heavy isomers as compared with those of light ones<sup>\*\*\*)</sup>.

On the other hand, we have experienced in the course of the work<sup>4)</sup> that a faint shoulder appears in the trailing edge of the deuterium peak in particular when the column efficiency for the separation of HD and D<sub>2</sub> was high enough. Therefore the 13 X column of various lengths were prepared and investigated for the separation. These are shown in Fig. 3 in which (a) is the one obtained with 2 meter column, (b) the one with 6 meter and (c) the one with 10 meter

\*) Equilibrium percentages of parahydrogen and orthohydrogen are 51.86 and 48.14% respectively at 75°K. See Ref. 12, p. 14.

\*\*\*) In this paper the room temperature 20-23°C will be taken as the standard temperature.

\*\*\*\*) The factor  $h^2/8\pi^2I$  for H<sub>2</sub> in the formula  $E_J = J(J+1)h^2/8\pi^2I$  is about twice as large as for D<sub>2</sub> because  $I_{H_2} = 4.67 \cdot 10^{-41}$  and  $I_{D_2} = 9.31 \cdot 10^{-41}$  g. cm<sup>2</sup>.

*Separation of Parahydrogen, Orthohydrogen by Gas Adsorption Chromatography*

column.

Since ordinary hydrogen was used in this case, hydrogen peak should not appear in the chromatogram. It is apparent that the first sharp peak in any of the chromatogram (a), (b) and (c) is that of HD. The second high and the third low peaks would be ortho- and paradeuterium respectively, because normal deuterium is consisted of 2 parts ortho- and 1 part paradeuterium and

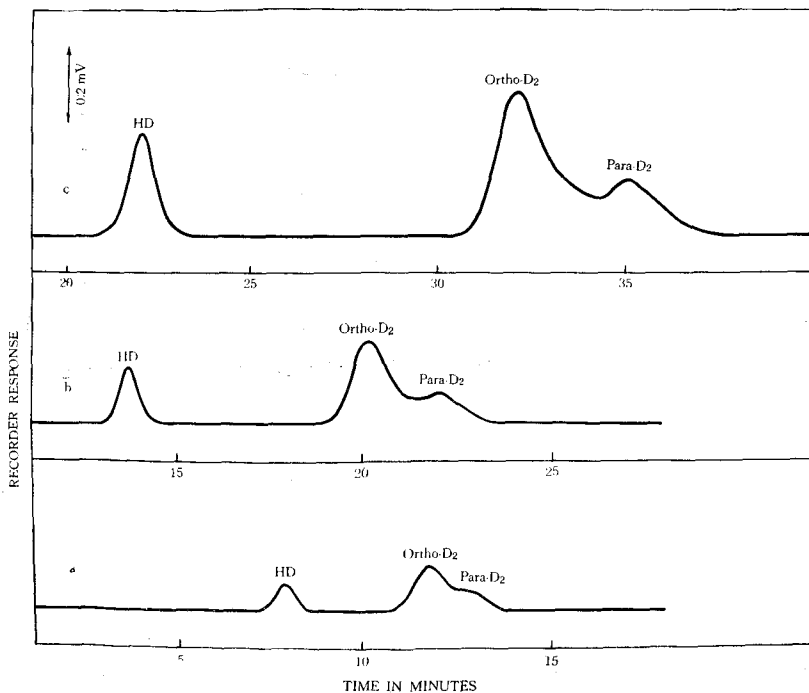

**Fig. 3.** Chromatograms for HD, orthodeuterium and paradeuterium.

Carrier gas; Ordinary hydrogen.

Column; Coiled copper tubing of various lengths having 0.4 cm inside diameter.

Column packing; Molecular sieve 13×30-60 meshes.

Column temperature;  $-195^{\circ}\text{C}$ .

Chart speed; 10 mm/min.

- (a) Heavy hydrogen 2.4 cc STP. Column length; 2 meters. Inlet pressure;  $0.25\text{ kg/cm}^2$ . Flow rate;  $412\text{ ml/min}$ . Span; 2 mV. Bridge current; 200 mA.
- (b) Heavy hydrogen 3.8 cc STP. Column length; 6 meters. Inlet pressure;  $0.7\text{ kg/cm}^2$ . Flow rate;  $570\text{ ml/min}$ . Span; 2 mV. Bridge current; 240 mA.
- (c) Heavy hydrogen 8.1 cc STP. Column length; 10 meters. Inlet pressure;  $0.85\text{ kg/cm}^2$ . Flow rate;  $400\text{ ml/min}$ . Span; 2 mV. Bridge current; 220 mA.

hence molecular species that gives larger peak area may naturally be attributed to orthodeuterium. It is not guaranteed however that the ortho-para deuterium conversion is absent at all during the passage through the column. Typical chromatograms for hydrogen isotopes and isomers are reproduced also in Photo. 2.

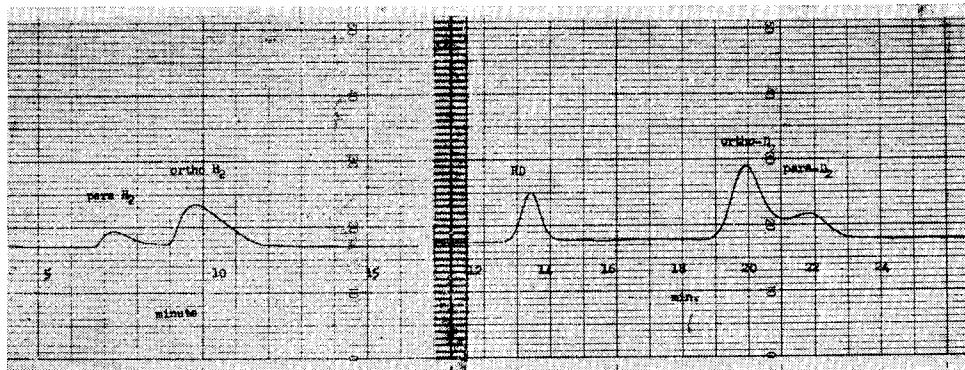

Photo. 2. Typical chromatograms for hydrogen isomers and isotopes.

At liquid nitrogen temperature almost all para and ortho molecules are found at their lowest rotational energy levels<sup>12)</sup>, *i. e.* the rotational quantum number  $J=0$  for parahydrogen and  $J=1$  for orthohydrogen. Assuming then adsorbed hydrogen to be rigid plane rotator, SANDLER<sup>9)</sup> calculated the separation factor almost agreed with the observed value. Similar calculation, *i. e.*  $J=1$  for paradeuterium and  $J=0$  for orthodeuterium, yielded much smaller value<sup>\*)</sup> for the separation factor of orthodeuterium and paradeuterium at 78.4°K.

\*) Rotational partition function of para-H<sub>2</sub>, ortho-H<sub>2</sub>, para-D<sub>2</sub> and ortho-D<sub>2</sub> at their lowest energy level is given respectively by

$$\begin{aligned} Q^{p-H_2} &= 1 & Q^{p-D_2} &= 9 \exp(-2B^{D_2}/kT) \\ Q^{o-H_2} &= 9 \exp(-2B^{H_2}/kT) & Q^{o-D_2} &= 6 \end{aligned}$$

where  $B = h^2/8\pi^2 I$ . On the other hand, rotational partition function of the adsorbed molecule may be expressed as below provided that the molecule is approximated by rigid plane rotator (cf. L. PAULING and E. B. WILSON Jr. "Introduction to Quantum Mechanics", McGraw-Hill Book Co. Inc. New York, 1935, p. 177);

$$\begin{aligned} q^{p-H_2} &= 1 & q^{p-D_2} &= 6 \exp(-B^{D_2}/kT) \\ q^{o-H_2} &= 6 \exp(-B^{H_2}/kT) & q^{o-D_2} &= 6. \end{aligned}$$

Separation factor for the adsorption of para- and orthohydrogen or of ortho- and paradeuterium can now be expressed in terms of rotational partition function as  $(Q/q)_{p-H_2}/(Q/q)_{o-H_2}$  or  $(Q/q)_{o-D_2}/(Q/q)_{p-D_2}$  and calculated to be 1.7 and 1.07 at 78.4°K.

EVETT<sup>13)</sup> recently proposed a "realistic, but still idealized model" for the adsorbed hydrogen molecule to give better agreement with the experimental value. Theoretical treatment of this kind was made also by TAKAISHI with hindered rotator model to deduce theoretical separation factor for hydrogen and deuterium (private communication, to be read before the 13 th meeting of Japan Chemical Society, April, 1960 Tokyo).

Thus, the gas chromatographic separation of heavy isomers ought to be more difficult than that of light isomers as shown already by the experiment.

MIYAHARA and the present author<sup>7)</sup> recently isolated isotopically pure light hydrogen by self-displacement technique using a very long molecular sieve column kept at liquid nitrogen temperature. It is obvious now that the concentration of parahydrogen is ready with this technique or the *light hydrogen* could have been parahydrogen itself, since the chromatographic elution of orthohydrogen was little different from that of HD as shown in Fig. 2. At the moment, the author would like to point out that the method could be useful to enrich parahydrogen without using conversion catalyst and in the absence of super refrigerant such as liquid helium.\*<sup>8)</sup> Enrichment of orthohydrogen or para-deuterium from normal hydrogen or normal deuterium could also be possible by the technique used by us<sup>6)</sup> previously to enrich deuterium from a mixture of hydrogen isotopes.

To analyze hydrogen isotopes, the hydrogen carrier method reported by us<sup>9)</sup> proved useful and convenient. To analyze hydrogen isomers, the helium carrier method<sup>10)</sup> could be adequate. Since, however, the molecular sieve used here as column packing was not inert toward orth-para conversion, the packings such as alumina might be preferred for analytical purpose. The sensitivity of the helium carrier method was found to increase to a considerable extent by using a combustion tube containing copper oxide. The overlapping of orthohydrogen and HD in the chromatogram of the helium carrier method is not at all disadvantageous for analytical purpose, that is, it may well work for the analyses of such component in the hydrogen isotopes and isomers by a *single* chromatogram.

Suppose a kind of chemical reaction in which pure parahydrogen and normal deuterium are the only participants. Two separate peaks are to be obtained on the chromatogram for the initial hydrogen sample. After the reaction, a mixture of H<sub>2</sub>, HD and D<sub>2</sub> may be obtained. The chromatogram of this sample of known volume would give three peaks corresponding parahydrogen, orthohydrogen plus HD and lastly deuterium.

The concentration of parahydrogen as well as of deuterium may be evaluated immediately from the corresponding peak area. The amount of HD ought to be twice that of deuterium disappeared during the reaction. The amount of orthohydrogen is, on the other hand, equal to the number of para-

\*<sup>8)</sup> Preliminary experiment indicated that the concentration of parahydrogen from normal hydrogen is readily possible by the self-displacement technique. The preparation of *pure* parahydrogen should not be possible, in principle, due to the ortho-para conversion activity shown simultaneously by the molecular sieve packing. Detailed account on this subject will be presented in a later date.

hydrogen molecule disappeared minus a half of HD molecules produced. If the initial hydrogen sample is an equimolar mixture of parahydrogen and deuterium, the amount of orthohydrogen is given by

$$[\text{O-H}_2] = [\text{D}_2]_t - [\text{P-H}_2]_t$$

where  $[\text{D}_2]_t$  and  $[\text{P-H}_2]_t$  are the amounts of deuterium and parahydrogen respectively at the reaction time  $t$ .

The usefulness of simultaneous analysis of hydrogen isotopes and isomers might be found in the study of the metal surface catalyzed reaction of hydrogen with deuterium and of the ortho-para hydrogen conversion or for instance, in the recent work of TAMIYA<sup>14)</sup> who observed the rates of ortho-para hydrogen conversion and deuterium exchange reaction in the para-H<sub>2</sub>-H<sub>2</sub>O system as well as in the para-H<sub>2</sub>-D<sub>2</sub>O system in the presence of hydrogenase to see the action of the enzyme.

#### Acknowledgment

The author wishes to express his appreciation to Mr. S. OHKOSHI for his constant assistance throughout this work.

#### References

- 1) H. S. TAYLOR and W. BREAKNEY, *Phys. Rev.* **43**, 490 (1933).
- 2) A. J. GOULD, W. BREAKNEY and H. S. TAYLOR, *J. Chem. Phys.* **2**, 302 (1934).
- 3) S. Z. ROGINSKY, *Theoretical Principles of Isotope Methods for Investigating Chemical Reactions*, Academy of Sciences, USSR Press, Moscow, 1956.
- 4) S. FURUYAMA and T. KWAN, to be submitted for publication.
- 5) S. OHKOSHI, T. FUJITA and T. KWAN, *Bull. Chem. Soc. Japan* **31**, 771 (1958).
- 6) S. OHKOSHI, S. TENMA, Y. FUJITA and T. KWAN, *ibid.* **31**, 773 (1958).
- 7) S. OHKOSHI, S. TENMA, Y. FUJITA and T. KWAN, *ibid.* **31**, 774 (1958).
- 8) K. MIYAHARA and T. KWAN, *J. Res. Inst. Catalysis*, **7**, 77 (1959).
- 9) D. WHITE and W. J. HAUFACH, *J. Chem. Phys.* **30**, 1368 (1959).
- 10) Y. L. SANDLER, *J. Phys. Chem.* **58**, 58 (1954).
- 11) Y. L. SANDLER, *J. Chem. Phys.* **29**, 97 (1958).
- 12) W. R. MOORE and H. R. WARD, *J. Am. Chem. Soc.* **80**, 2909 (1958).
- 13) C. M. CUNNINGHAM, D. S. CHAPIN and H. L. JOHNSTON, *J. Am. Chem. Soc.* **80**, 2382 (1958).
- 14) A. FARKAS, *Parahydrogen, Orthohydrogen and Heavy Hydrogen*, Cambridge University Press, 1935, p. 14.
- 15) A. A. Evett, *J. Chem. Phys.* **30**, 565 (1959).
- 16) N. TAMIYA, *Symposium on Enzyme Chemistry, Japan* **13**, 25 (1958).
- 17) M. P. FREEMAN, *J. Phys. Chem.* **64**, 32 (1960).