



# HOKKAIDO UNIVERSITY

|                  |   |
|------------------|---|
| Title            | THE BEHAVIOR OF PLATINUM ELECTRODES : Part 2. Effects of Anodic Electrolysis in Acid Solution |
| Author(s)        | MITUYA, Atusi; ŌBAYASHI, Takeko   |
| Citation         | JOURNAL OF THE RESEARCH INSTITUTE FOR CATALYSIS HOKKAIDO UNIVERSITY, 8(2), 79-85              |
| Issue Date       | 1960-10   |
| Doc URL          | <a href="https://hdl.handle.net/2115/24720">https://hdl.handle.net/2115/24720</a>             |
| Type             | departmental bulletin paper   |
| File Information | 8(2)_P79-85.pdf   |



# THE BEHAVIOR OF PLATINUM ELECTRODES

## Part 2. Effects of Anodic Electrolysis in Acid Solution

By

Atsusi MITUYA and Takeko ŌBAYASHI<sup>\*)</sup>

(Received April 18, 1960)

Disintegration of the platinum anode irradiated with neutrons was investigated in a previous work<sup>(1)</sup>. Insofar as the result of that work is concerned, the observed disintegration may be attributed to either or both the anodic treatment and the neutron bombardment. In the present work the platinum electrode has been anodically polarized in 0.1N-HCl to different potentials either in air or in hydrogen atmosphere and the disintegration was followed radiometrically by preliminarily irradiating it with neutrons. It was found that the disintegration was caused solely by a severe anodic treatment in air and not by the neutron bombardment.

### Experimental Procedure

Blank platinum wires of 0.5 mm diameter and 18 mm length, and of 99.99% purity as guaranteed by TANAKA Precious Metal Work Co., were washed and sealed in a polyethylene sack as described in the previous paper<sup>(1)</sup> and then bombarded with neutrons in the atomic reactor J. R. R.-1. One of these platinum wires thus treated was carefully worked out to make an electrode A, shown in Fig. 1; and this was polarized anodically in 0.1N-HCl against a platinized platinum electrode, C, in hydrogen and then in air. The polarization was measured with reference to

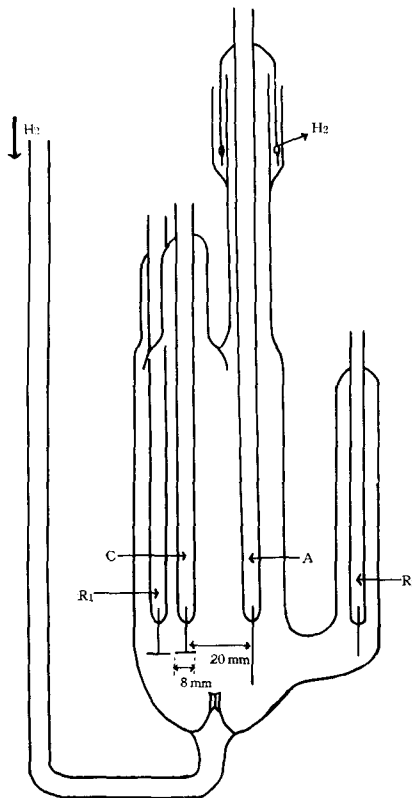

Fig. 1. Electrolytic cell

<sup>\*)</sup> A. M. and T. O.: Department of Chemistry, St. Paul's University (Rikkyo Daigaku), Tokyo.

another platinized platinum electrode  $R_1$  in hydrogen, or to a silver-silver chloride reference electrode  $R_2$  (Ag/AgCl/0.1N-HCl) in air. The current density of electrode A and the appropriate potentials of electrodes A and C against  $R_1$  or  $R_2$  were observed during the electrolyses similarly as in the previous work.

After each electrolysis, the solution was concentrated to about 2cc (*ca.* 1:20) by evaporation, and its radioactivity was measured by a scintillation spectrometer. The hydrogen gas used was prepared by electrolysis of water and purified by passing it through a heated tube filled with Pd-impregnated asbestos.

The tenth normal hydrogen chloride was prepared similarly as described in the previous work<sup>(1)</sup>.

### Result

#### (a) Electrolysis in hydrogen.

Two samples of anodes were subjected to anodic treatments in two stages in hydrogen, as shown in Table 1.

TABLE 1. Conditions of the anodic treatment of the platinum electrode in hydrogen.

| Sample No. | Stage | Applied potential between A-C | Anodic polarization against |        | Current density of A (amp/cm <sup>2</sup> ) | Time of duration of Electrolysis | Electrolyte | Concentrated electrolytes |
|------------|-------|-------------------------------|-----------------------------|--------|---|----------------------------------|-------------|---------------------------|
|            |       |                               | $R_1$                       | $R_2$  |   |                                  |             |                           |
| 1          | 1st   | 0.54 v                        | 0.54 v                      | 0.19 v | $1.75 \times 10^{-5}$                       | 89                               | 0.1N-HCl    | 1-A                       |
|            | 2nd   | 1.53 v                        | 1.53 v                      | 1.18 v | $1.6 \times 10^{-4}$                        | 89                               | 0.1N-HCl    | 1-B                       |
| 2          | 1st   | 0.53 v                        | 0.53 v                      | 0.18   | $2.3 \times 10^{-5}$                        | 86                               | 0.1N-HCl    | 2-A                       |
|            | 2nd   | 1.53 v                        | 1.53 v                      | 1.18   | $3.6 \times 10^{-4}$                        | 89                               | 0.1N-HCl    | 2-B                       |

Measurement of radioactivity was made for the concentrated electrolytes designated 1-A, 1-B, 2-A, and 2-B of Table 1, and for the irradiated platinum wire. Fig. 2 shows the  $\gamma$ -ray spectrum of the platinum wire in comparison with that of the one used in the previous report (observed 1.15 years after the neutron irradiation).

We see clearly from Table 1 that in hydrogen atmosphere only the anodes are polarized at current densities below  $4 \times 10^{-4}$  amp/cm<sup>2</sup>: the platinized platinum cathode C is not polarized at all. From Table 2 we see that in hydrogen atmosphere the electrolyses do not cause any disintegration of the platinum surface at all, even when the platinum electrodes are polarized anodically by 1.5V against the reversible hydrogen potential. This result now clearly shows

The Behavior of Platinum Electrodes Part 2

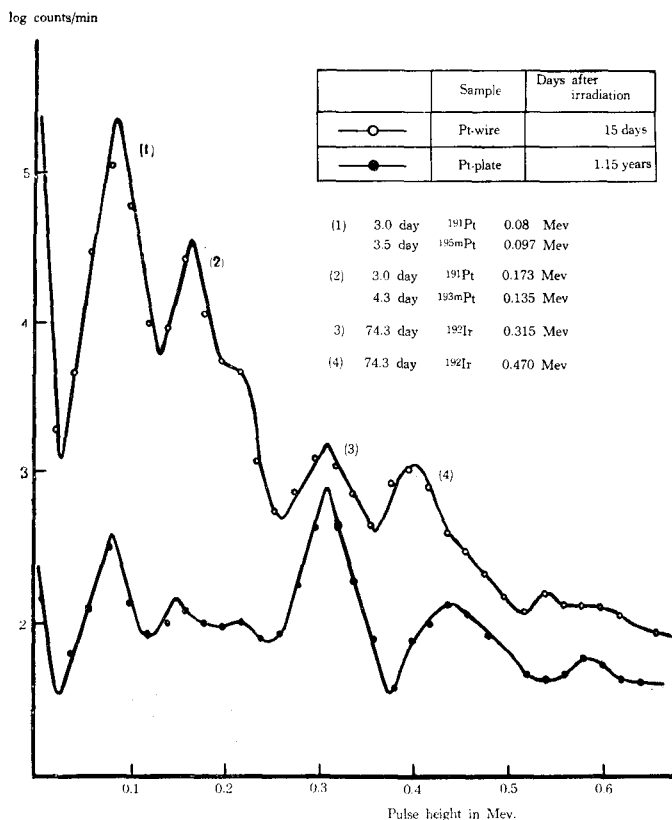

Fig. 2.  $\gamma$ -ray spectra of irradiated platinum.

that the disintegration is not caused by neutron bombardment.

(b) Electrolysis in air.

The anode potential was observed with reference to the Ag-AgCl electrode, R<sub>2</sub>, in the case when the reference electrode R<sub>1</sub> remained no longer at its fixed potential as referred to R<sub>2</sub>, for an anodic polarization in air to a certain level of A against C of Fig. 1. Table 3 summarizes the results of the anodic electrolysis in air of sample No. 1 of Table 1, which followed the electrolysis in hydrogen.

Table 3 shows about 80 signal counts per 60 min. above the background due to radioactive Pt in the solution.

(c) Detection of radioactive platinum in solution after electrolysis in air.

A standard source of <sup>57</sup>Co, calibrated and guaranteed on 19 August 1959

TABLE 2. Results of radioactivity detection

| Designation  | 1-A  | 1-B  | 2-A       | 2-B           |
|--|------|------|-----------|---------------|
| Net counts of signal per min.  | None | None |           |               |
| Counts of signals from 0.080 Mev. to 0.100 Mev. energy** per 60 min. |      |      | 296±17.2* |               |
| Background   |      |      | 302±17.3* |               |
| Net counts of signals  |      |      | None      |               |
| Counts of signals above 0.100 Mev. energy*** per 60 min.             |      |      |           | 26,097±161.5* |
| Background   |      |      |           | 25,966±161.1* |
| Net counts of signals  |      |      |           | None          |

\* These values were obtained as calculated mean values on successive blank-sample-blank-sample observations each over a period of 60 min.

\*\* , \*\*\* According to the previous work, these observations indicate the presence or the absence of Pt, and of other metals, respectively.

TABLE 3. Results of anodic electrolysis in air.

| Sample No. | Applied potential between A-C  | Anodic polarization against R <sub>2</sub> | Current density of A (amp/cm <sup>2</sup> ) | Time of duration of electrolysis | Electrolyte |
|------------|--|--|---|----------------------------------|-------------|
| 1          | 1.560 v  | 1.605 v                                    | 4.5×10 <sup>-5</sup>                        | 95 hrs                           | 0.1N-HCl    |
| Run        | Counts of signals from 0.080 Mev. to 0.100 Mev. energy** per 60 min. |  |   |                                  |             |
|            | Concentrated sample solution   |  | Background                                  |                                  |             |
| 1st        | 420  |  | 342   |                                  |             |
| 2nd        | 437  |  | 371   |                                  |             |
| 3rd        | —  |  | 345   |                                  |             |
| Mean       | 429±21*  |  | 353±19*                                     |                                  |             |

\* The values in Table 3 were obtained by successive blank-sample-blank-sample-blank observations, each over a period of 60 min.

\*\* This signal denotes the existence of radioactive <sup>195m</sup>Pt.

by the New England Nuclear Corp., was examined for its activity by our apparatus 193 days after that calibration. The activity of a platinum sample was determined in "curies" from "counts per min." of the sample on the basis of the calibrated activity in "counts per min." of the standard source against "curies", since <sup>57</sup>Co irradiates low energy  $\gamma$ -ray of 0.123 Mev., about the same value as for <sup>195m</sup>Pt. The "curies" of the platinum sample was calculated

as follows from the data given for the standard source of  $^{57}\text{Co}$  and from the observations given below.

|                                       |  |
|---------------------------------------|--|
| $^{57}\text{Co}$ : half life $T$      | 270 days   |
| initial activity                      |  |
| in curies $N_0$                       | $0.110 \times 10^{-6}$ curie   |
| in total counts $R_0$ above 0.02 Mev. | 124,600 counts/min.  |
| activity after 193 days               |  |
| in curie $N_t$                        | $N_t = N_0 \exp(-0.693 \times 193/270)$<br>$= 0.0670_2 \times 10^{-6}$ curie |
| in total counts $R_t$ above 0.02 Mev. | . . . . .  |
|                                       | $R_{t, \text{cal}} = 75,913$ counts/min.                                     |
|                                       | $R_{t, \text{obs}} = 75,844$ counts/min.                                     |

It follows that, from  $R_t$  observed by our apparatus being in close agreement with that calculated, "1 count per min." corresponds to  $1 \mu\mu\text{c}$  of the sample, *i.e.*, 2 disintegrations of atoms per min. As shown in Table 3, the test sample in this experiment gave about 80 signal counts of the energy from 0.08 Mev to 0.10 Mev per 60 min. corresponding to disintegrated  $^{195\text{m}}\text{Pt}$  at 1.96 volt polarization against reversible hydrogen potential in 0.1N-HCl in air. This indicates the existence of about  $1.5 \mu\mu\text{c}$  of  $^{195\text{m}}\text{Pt}$  in the solution at that moment. Since the half life of  $^{195\text{m}}\text{Pt}$  is 3.5 days, the whole amount of activity of disintegrated  $^{195\text{m}}\text{Pt}$  must have been  $117 \mu\mu\text{c}$  ( $1.84 \times 10^6$  atoms), at the time the neutron bombardment was stopped. The data from the "Chart"<sup>(2)</sup> and of the known neutron flux,  $5.1 \times 10^{11}$  n/cm<sup>2</sup>/sec, and the time of irradiation (2 hrs) in the bombardment of the platinum target enable us now to calculate the activity of  $^{195\text{m}}\text{Pt}$ \*) of the target at that time as  $20 \mu\mu\text{c}$  ( $3.33 \times 10^{11}$  atoms), *i.e.* that  $4.36 \times 10^{-9}$  part of  $^{194}\text{Pt}$  had been activated. Since the number of  $^{194}\text{Pt}$  atoms at the surface of the target is  $3.3 \times 10^{13}$ , the number of  $^{195\text{m}}\text{Pt}$  atoms at the surface must have been  $1.39 \times 10^5$ , from which it follows that about 13 layers of platinum electrode surface had dissolved, *i.e.*  $1.3 \times 10^{15}$  platinum atoms in total.

### Discussion

The experimental results show that platinum atoms go into acid solution only when the platinum is appreciably polarized anodically in air. When the platinum electrode was anodically polarized in air by about 1.9 volt against the reversible hydrogen potential, about  $1.84 \times 10^6$  atoms of radioactive platinum (*i.e.*, about  $1.3 \times 10^{15}$  atoms for the total platinum) could be found in the solution

\*)  $^{194}\text{Pt}$  creates  $^{195\text{m}}\text{Pt}$  by  $(n, \gamma)$  reaction.

after 95 hrs electrolysis, whereas no signals from radioactive platinum in the solution could be detected in the case of electrolysis in hydrogen nor in air at anodic polarization lower than 1 volt<sup>(1)</sup>.

FRUMKIN<sup>(3)</sup> noted that the current density of the mercury electrode at extremely low overvoltage observed previously by one of the present authors<sup>(4)</sup>, as compared with the experimental results of LEVINA and SARINSKY<sup>(5)</sup>, and of JOFA<sup>(6)</sup>, was larger; and he attributed this to the contamination of the mercury cathode by the platinum anode in hydrogen atmosphere placed close to the cathode. He states that a platinum electrode preliminarily exposed to air is covered with oxide film, which disintegrates on contact with acid before the introduction of hydrogen to contaminate the mercury cathode surface. If that is so, then, the numbers of those oxidized platinum atoms in the present experiment must be of the order of magnitude of  $10^{14}$ , which should be amply detected by signals of radioactivity as seen from (c) of the foregoing section, insofar as the disintegration of oxide film was not partial. This possibility of contamination is further excluded by the experimental fact<sup>(4)</sup> that the change of cathode surface area had no effect on the current density at a definite overpotential. The cause of the above discrepancy might be sought alternatively in the difference in the preparation of the electrolytic cells between that used by one of the present authors<sup>(4)</sup> and by them<sup>(5,6)</sup>, *i.e.*, whether or not high vacuum technique is employed.

Several workers<sup>(7,8,9,10,11)</sup> have reported that, in the electrolysis of blank platinum by alternating current in sulphuric acid, they found the existence of platinum oxide, platinum salt, or platinum black on the platinum electrode surface. They stated that platinum was not etched by anodic electrolysis with D.C., but the present results show a definite disintegration by an extreme anodic polarization in air. It follows that the generally advocated method of purification of the electrolyte solution by "pre-electrolysis" must be followed by distillations in order to assure a high degree of purity of the electrolyte.

#### **Acknowledgement**

The authors would like to express their gratefulness to Professor J. HORIUTI of Hokkaido University for his encouragement and to Professor A. N. FRUMKIN of the Academy of Science of the U.S.S.R. for his valuable suggestions. A part of this work was financially aided by the Grant for Scientific Research in the items of Joint Utilization of Japan's Research Reactor-1.

### References

- 1) A. MITUYA, T. ŌBAYASHI, this Journal **7**, 10 (1959).
- 2) W. H. SULLIVAN, Trilinear Chart of Nuclides, Jan. (1959).
- 3) A. N. FRUMKIN, this Journal **8**, 10 (1960).
- 4) A. MITUYA, *ibid.* **4**, 228 (1956).
- 5) S. D. LEVINA, V. A. SARINSKY, J. Physic. Chem. (USSR), **9**, 627 (1937).
- 6) S. A. JOFA, J. Physic. Chem. (USSR), **13**, 1435 (1939).
- 7) J. W. SHIPLAY, C. F. GOODEVE, Trans. Am. Electrochem. Soc. **51**, 375 (1925).
- 8) K. KOYANO, S. SHIBATA, J. Chem. Soc. Japan, **75**, 262 (1954).
- 9) E. BRINER, Yalda, Helv. Chim. Acta., **26**, 1162 (1943).
- 10) A. RIUS, J. LLOPIS, F. Colom, Chem. Abst. **47**, 8055 (1955).
- 11) S. SHIBATA, J. Chem. Soc. Japan, **79**, 239 (1958); **80**, 453 (1959).