



# HOKKAIDO UNIVERSITY

Title	A GENERAL RELATION BETWEEN FORWARD AND BACKWARD ISOTOPE SEPARATION FACTORS IN THE HYDROGEN ELECTRODE REACTION
Author(s)	YOKOYAMA, Takamitsu; ENYO, Michio
Citation	JOURNAL OF THE RESEARCH INSTITUTE FOR CATALYSIS HOKKAIDO UNIVERSITY, 15(3), 207-217
Issue Date	1968-02
Doc URL	<a href="https://hdl.handle.net/2115/24838">https://hdl.handle.net/2115/24838</a>
Type	departmental bulletin paper
File Information	15(3)_P207-217.pdf



## A GENERAL RELATION BETWEEN FORWARD AND BACKWARD ISOTOPE SEPARATION FACTORS IN THE HYDROGEN ELECTRODE REACTION

By

Takamitsu YOKOYAMA\*<sup>1</sup>) and Michio ENYO\*<sup>2</sup>)

(Received September 27, 1967)

### Abstract

A general relation is derived between two electrolytic hydrogen-deuterium separation factors,  $S_f$  and  $S_b$ , respectively in the hydrogen evolution and ionization reactions on one and the same electrode in the system composed of "light" water (containing deuterium of the natural abundance) and hydrogen gas at any deuterium atomic fraction  $X^G$ .

The relation was found to depend on the value of  $\nu$ , the stoichiometric number of the rate-determining step of the hydrogen electrode reaction. In the case of  $\nu=1$ ,  $S_f$  is given as  $S_f=Q_{L-G,o}\sigma_{23}$  at any  $X^G$ -value, where  $Q_{L-G,o}$  is the partition coefficient of deuterium between aqueous solution and hydrogen gas at  $X^G \approx 0$  and  $\sigma_{23}$  is the ratio of specific rate of ionization of  $H_2$  to that of HD; the latter is determined from  $S_b$ . In the case of  $\nu=2$ , the relation is  $S_f=Q_{L-G,o}S_b(m^{HD}/2m^{H_2})(1-X^G)/X^G$ , where  $m$  is the mole fraction of the species specified.

The former relation was applied to several systems, all of which are known to belong to the case  $\nu=1$ . From  $S_b$  obtained by measuring the isotopic mixed potential of the hydrogen electrode in the system composed of light water and deuterium-containing hydrogen, the following  $S_f$ -values were obtained at 25°C: 3.9 for Au in 1N  $H_2SO_4$ , 4.2 for Pt and 6.2 for Ni both in 0.1N NaOH solution.

### Introduction

The isotope effect in the hydrogen electrode reaction (HER),

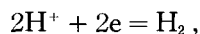

is expressed in terms of the electrolytic isotope separation factor, usually that in the forward reaction (hydrogen *evolution* reaction),  $S_f$ , defined (for H-D separation) as

$$S_f \equiv \frac{V_f^H}{1-X^L} \bigg/ \frac{V_f^D}{X^L}, \quad (1.f)$$

\*<sup>1</sup>) The Research Institute for Catalysis, Hokkaido Univ., Sapporo, Japan.

where  $V_f^H$  and  $V_f^D$  are, respectively, the overall unidirectional forward rates of transfer of light hydrogen and of deuterium and  $X^L$  is the atomic fraction of deuterium in aqueous electrolyte. It has been widely accepted that  $S_f$  is characteristic of the mechanism of the HER, and hence a number of investigations have been devoted to its experimental determination<sup>1-4)</sup> and theoretical interpretation.<sup>5)</sup>

Only few reports are available<sup>6,7)</sup> on the separation factor in the backward reaction (hydrogen *ionization* reaction),  $S_b$ , defined as

$$S_b \equiv \frac{V_b^H}{1-X^G} / \frac{V_b^D}{X^G}, \quad (1. b)$$

where  $V_b^H$  and  $V_b^D$  are, respectively, the overall unidirectional backward rates of transfer of light hydrogen and of deuterium and  $X^G$  is the atomic fraction of deuterium in the hydrogen gas.

The authors have recently established<sup>8)</sup> a reliable and convenient method of determining  $S_b$  by the observation of the isotopic mixed potential of hydrogen electrode in the system composed of solution of light water and deuterium-containing hydrogen as referred to the reversible hydrogen electrode potential in the light hydrogen system under otherwise the same conditions. Accordingly, it is desirable to establish a quantitative relation between  $S_f$  and  $S_b$  on one and the same electrode in order to derive  $S_f$  from  $S_b$  thus obtained.

We readily see from the definitions that, under the condition where the isotopic exchange equilibrium is established between hydrogen gas and aqueous solution, the ratio  $S_f/S_b$  yields the partition coefficient  $Q_{L-G}$  of deuterium, *i. e.*,

$$S_f = S_b \cdot Q_{L-G} \quad (\text{under the exchange equilibrium})^9) \quad (2)$$

where  $Q_{L-G}$  is defined as

$$Q_{L-G} \equiv \left[ \frac{X^L}{1-X^L} / \frac{X^G}{1-X^G} \right]_{\text{eq.}} \quad (3)$$

Eq. (2) does not generally apply to the case where the exchange equilibrium is not attained. However, it has been demonstrated<sup>9)</sup> that the relation still holds under non-equilibrium conditions provided that both  $X^L$  and  $X^G$  are sufficiently small and that the hydrogen gas is equilibrated with respect to the isotopic equilibration reaction,



The present paper is devoted to establish a quantitative relation between  $S_f$  and  $S_b$  which covers the whole range of  $X^G$ , while keeping  $X^L$  throughout at the natural abundance,  $X^L_0$ . This choice of  $X^L$  is made since  $S_f$ -values

*Forward and Backward Isotope Separation Factors*

treated experimentally and theoretically in the literature are usually those at low  $X^L$ . Based on the relation established in this work, values of  $S_f$  on several metals are obtained from  $S_b$  which is determined from the isotopic mixed potential.<sup>8)</sup>

### Theoretical

We consider the test electrode T in the system composed of a "light" water solution (containing deuterium of the natural abundance) and hydrogen gas which contains an arbitrary amount of deuterium (Fig. 1, a). For this

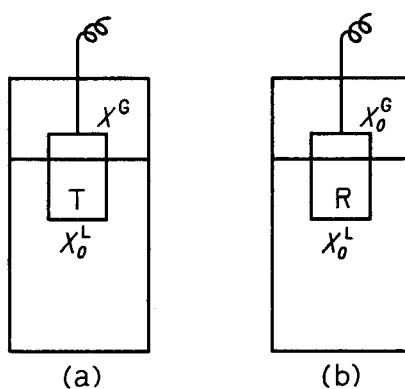

**Fig. 1.** (a) Test hydrogen electrode at rest in the system composed of "light" water (containing deuterium of the natural abundance, deuterium atomic fraction  $X_o^L$ ) and deuterium-containing hydrogen gas (deuterium atomic fraction  $X^G$ ).  
 (b) Reversible hydrogen electrode in the "light" hydrogen system (deuterium atomic fractions  $X_o^L$  and  $X_o^G$ )

system, Eq. (1.f) is specialized as

$$S_{f,o} = \frac{V_f^H}{1 - X_o^L} \bigg/ \frac{V_f^D}{X_o^L}, \quad (5)$$

or using  $Q_{L-G,o}$ , the value of  $Q_{L-G}$  at  $X^L = X_o^L$  and  $X^G = X_o^G$ , *i. e.*

$$Q_{L-G,o} = \left[ \frac{X_o^L}{1 - X_o^L} \bigg/ \frac{X_o^G}{1 - X_o^G} \right]_{\text{eq.}}, \quad (6)$$

as

$$S_{f,o} = Q_{L-G,o} \cdot \frac{X_o^G}{1 - X_o^G} \cdot \frac{V_f^H}{V_f^D}. \quad (7)$$

The last factor in Eq. (7) has to be treated separately according as the stoichiometric number  $\nu$  of the rate-determining step of the HER equals 1

and 2, respectively.<sup>8)</sup> It is premised in the present treatment that the hydrogen isotope is transferred from the gas phase to the solution or in its reverse direction always through the rate-determining step of the HER.\*)

(A) Case  $\nu = 1$

From the premise stated above, it follows that two hydrogen nuclei are necessarily involved in the rate-determining step in this case.\*\*) A typical example of this case is the so-called catalytic mechanism, *i. e.*,

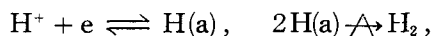

with the latter step determining the rate, where H(a) represents chemisorbed hydrogen atom on the electrode. Eq. (7) is rewritten in this case as

$$S_{f,o} = Q_{L-o,o} \cdot \frac{X_o^G}{1 - X_o^G} \cdot \frac{2v_f^{\text{H}_2} + v_f^{\text{HD}}}{2v_b^{\text{H}_2} + v_b^{\text{HD}}}, \quad (8)$$

where  $v_f^{\text{H}_2}$  etc. are the unidirectional forward rate of transfer by the rate-determining step of  $\text{H}_2$  etc.

Here,  $v_f^{\text{H}_2}$  is related to the backward rate  $v_b^{\text{H}_2}$  and chemical potentials of the relevant species as<sup>10)</sup>

$$v_f^{\text{H}_2}/v_b^{\text{H}_2} = \exp \left[ (2\mu^{\text{H(a)}} - \mu^{\text{H}_2})/RT \right].$$

On account of the partial equilibrium of the step,  $\text{H}^+ + \text{e} \rightleftharpoons \text{H(a)}$ ,  $\mu^{\text{H(a)}}$  is equal to  $\mu_o^{\text{H}^+} + \mu^{\text{e}}$ . Hence we have

$$v_f^{\text{H}_2}/v_b^{\text{H}_2} = \exp \left[ (2\mu_o^{\text{H}^+} + 2\mu^{\text{e}} - \mu^{\text{H}_2})/RT \right], \quad (9. \text{H}_2)$$

where the subscript, *o*, signifies the quantity in "light" water. Similarly we have, respectively, for HD and  $\text{D}_2$ ,

$$v_f^{\text{HD}}/v_b^{\text{HD}} = \exp \left[ (\mu_o^{\text{H}^+} + \mu_o^{\text{D}^+} + 2\mu^{\text{e}} - \mu^{\text{HD}})/RT \right] \quad (9. \text{HD})$$

and

$$v_f^{\text{D}_2}/v_b^{\text{D}_2} = \exp \left[ (2\mu_o^{\text{D}^+} + 2\mu^{\text{e}} - \mu^{\text{D}_2})/RT \right]. \quad (9. \text{D}_2)^{***})$$

\*) This is experimentally found to be always the case;<sup>8)</sup> if this condition is not satisfied, no relation can be found between  $S_f$  and  $S_b$ .

\*\*\*) In the mechanism,  $\text{H}^+ + \text{e} \xrightarrow{\text{A}} \text{H(a)}$ ,  $\text{H(a)} + \text{H}^+ + \text{e} \rightleftharpoons \text{H}_2$ , which belongs to the case  $\nu = 1$ , only one hydrogen nucleus is involved in the rate-determining step. In this case, however, hydrogen can be transferred from gas phase to the solution and in its reverse direction without passing through the rate-determining step.

\*\*\*) Eq. (9) is also found in the case of the so-called electrochemical mechanism:



*Forward and Backward Isotope Separation Factors*

Further, the following relations hold for the reversible hydrogen electrode (where  $\mu^e = \mu_{\text{rev}}^e$ ) in the "light" hydrogen system under otherwise the same conditions, for the exchange equilibrium is established with regard to deuterium of the natural abundance though it is very little amount (Fig. 1, b),

$$2\mu_o^{\text{H}^+} + 2\mu_{\text{rev}}^e = \mu_o^{\text{H}_2}, \quad (10. \text{H}_2)$$

$$\mu_o^{\text{H}^+} + \mu_o^{\text{D}^+} + 2\mu_{\text{rev}}^e = \mu_o^{\text{HD}} \quad (10. \text{HD})$$

and

$$2\mu_o^{\text{D}^+} + 2\mu_{\text{rev}}^e = \mu_o^{\text{D}_2}. \quad (10. \text{D}_2)$$

Eliminating  $v_f^{\text{H}_2}$ ,  $v_f^{\text{HD}}$  and  $v_f^{\text{D}_2}$  from Eqs. (8) and (9) and replacing  $\mu_o^{\text{H}^+}$  etc. with  $\mu_o^{\text{H}_2}$  etc. by Eq. (10), we obtain

$$S_{f,o} = Q_{\text{L-G},o} \cdot \frac{X_o^{\text{G}}}{1 - X_o^{\text{G}}} \cdot \frac{2v_b^{\text{H}_2} \exp[(\mu_o^{\text{H}_2} - \mu^{\text{H}_2})/RT] + v_b^{\text{HD}} \exp[(\mu_o^{\text{HD}} - \mu^{\text{HD}})/RT]}{2v_b^{\text{D}_2} \exp[(\mu_o^{\text{D}_2} - \mu^{\text{D}_2})/RT] + v_b^{\text{HD}} \exp[(\mu_o^{\text{HD}} - \mu^{\text{HD}})/RT]}.$$

Now,  $\mu^{\text{H}_2}$ ,  $\mu_o^{\text{D}_2}$  etc. are in turn given as

$$\mu^{\text{H}_2} = \mu_1^{\text{H}_2} + RT \ln m^{\text{H}_2} \cdot P, \quad (11. \text{H}_2)$$

$$\mu_o^{\text{D}_2} = \mu_1^{\text{D}_2} + RT \ln m_o^{\text{D}_2} \cdot P \quad (11. \text{D}_2)$$

etc., where  $\mu_1^{\text{H}_2}$  and  $\mu_1^{\text{D}_2}$  are, respectively, the standard chemical potentials of  $\text{H}_2$  and  $\text{D}_2$ ,  $m^{\text{H}_2}$  and  $m_o^{\text{D}_2}$  are their mole fractions and  $P$  is the total hydrogen pressure. Substitution of  $\mu^{\text{H}_2}$  etc. from these equations into the above equation for  $S_{f,o}$  yields

$$S_{f,o} = Q_{\text{L-G},o} \cdot \frac{X_o^{\text{G}}}{1 - X_o^{\text{G}}} \cdot \frac{2v_b^{\text{H}_2} m_o^{\text{H}_2}/m^{\text{H}_2} + v_b^{\text{HD}} m_o^{\text{HD}}/m^{\text{HD}}}{2v_b^{\text{D}_2} m_o^{\text{D}_2}/m^{\text{D}_2} + v_b^{\text{HD}} m_o^{\text{HD}}/m^{\text{HD}}}. \quad (12)$$

Here, we define  $\sigma_{23}$  and  $\sigma_{24}$  as

$$\sigma_{23} \equiv \frac{v_b^{\text{H}_2}}{m^{\text{H}_2}} \bigg/ \frac{v_b^{\text{HD}}}{m^{\text{HD}}} \quad \text{and} \quad \sigma_{24} \equiv \frac{v_b^{\text{H}_2}}{m^{\text{H}_2}} \bigg/ \frac{v_b^{\text{D}_2}}{m^{\text{D}_2}}, \quad (13. \text{HD}), (13. \text{D}_2)$$

*i. e.*, as the ratio of the specific rate of ionization of  $\text{H}_2$  to that of HD and to that of  $\text{D}_2$ , respectively, these being assumed to be constant independent of the composition of the hydrogen gas. In terms of these "individual" separation factors, Eq. (12) assumes the form

$$S_{f,o} = Q_{\text{L-G},o} \cdot \frac{X_o^{\text{G}}}{1 - X_o^{\text{G}}} \cdot \frac{2m_o^{\text{H}_2}}{m_o^{\text{HD}}} \cdot \frac{\sigma_{23} + m_o^{\text{HD}}/2m_o^{\text{H}_2}}{1 + (2m_o^{\text{D}_2}/m_o^{\text{HD}})(\sigma_{23}/\sigma_{24})}. \quad (14)$$

The factor  $X_o^{\text{G}}/(1 - X_o^{\text{G}})$  is well approximated as  $m_o^{\text{HD}}/2m_o^{\text{H}_2}$  using the general relations,

$$1 - X^{\text{G}} = m^{\text{H}_2} + m^{\text{HD}}/2 \quad \text{and} \quad X^{\text{G}} = m^{\text{D}_2} + m^{\text{HD}}/2, \quad (15. \text{H}), (15. \text{D})$$

Takamitsu YOKOYAMA and Michio ENYO

with  $m_o^{\text{HD}}/m_o^{\text{H}_2} \simeq 10^{-4}$  and  $m_o^{\text{D}_2}/m_o^{\text{HD}} \simeq 10^{-4}$ . Further the second term in the denominator of the last factor in Eq. (14) is extremely small as compared with unity, and so is the second term in the numerator as compared with  $\sigma_{23}$  which is of the order of magnitude of unity. Hence, we have

$$S_{f,o} = Q_{\text{L-G},o} \cdot \sigma_{23}. \quad (16)$$

This result could physically be understood in the following way. Under the condition that the exchange equilibrium is established in the "light" hydrogen system, we clearly have the relation (cf. Eq. (2))

$$S_{f,o} = Q_{\text{L-G},o} \cdot S_{b,o}, \quad (17)$$

where  $S_{b,o}$  is the value of  $S_b$  at  $X^{\text{G}} = X_o^{\text{G}}$  and  $X^{\text{L}} = X_o^{\text{L}}$ . In the present case of  $\nu = 1$ ,  $S_b$  is given from Eqs. (1.b) and (15) as

$$S_b = \frac{2v_b^{\text{H}_2} + v_b^{\text{HD}}}{2v_b^{\text{D}_2} + v_b^{\text{HD}}} \cdot \frac{2m^{\text{D}_2} + m^{\text{HD}}}{2m^{\text{H}_2} + m^{\text{HD}}}, \quad (18)$$

or in terms of  $\sigma_{23}$  and  $\sigma_{24}$  as

$$S_b = \frac{1 + \sigma_{23}(2m^{\text{H}_2}/m^{\text{HD}})}{1 + (\sigma_{23}/\sigma_{24})(2m^{\text{D}_2}/m^{\text{HD}})} \cdot \frac{2m^{\text{D}_2} + m^{\text{HD}}}{2m^{\text{H}_2} + m^{\text{HD}}}. \quad (19)$$

Consequently,  $S_b$  may depend on the isotopic composition of the hydrogen gas.\*) As the "light" hydrogen gas now concerned is in equilibrium of reaction (4), we readily see that  $S_{b,o}$  is practically identical with  $\sigma_{23}$ , that is, we have Eq. (16) above. Even if we replace the hydrogen gas with hydrogen of any isotopic composition, it would cause no variation of  $S_{f,o}$  (nor of  $\sigma_{23}$  as assumed), that is, Eq. (16) is applicable in the whole range of  $X^{\text{G}}$ .

The last task of evaluating  $S_{f,o}$  is therefore the evaluation of  $\sigma_{23}$ . As stated above  $\sigma_{23}$  is determinable from a single measurement of  $S_b$  using an isotopically equilibrated hydrogen gas of sufficiently small  $X^{\text{G}}$ . If we use hydrogen of moderate or high  $X^{\text{G}}$ , two values of  $S_b$  at different isotopic compositions are required in the evaluation of  $\sigma_{23}$  (and of  $\sigma_{24}$  simultaneously) by Eq. (19).

### (B) Case $\nu = 2$

A typical example of this case is the so-called slow-discharge mechanism, *i. e.*,



with the former step determining the rate. In the present case the hydrogen

\*) If the hydrogen gas is composed of  $\text{H}_2$  and  $\text{D}_2$  only, it follows from Eq. (19) that  $S_b$  equals  $\sigma_{24}$  as it should be.

*Forward and Backward Isotope Separation Factors*

gas is necessarily equilibrated isotopically through the latter step which is premised to be in partial equilibrium.

The ratio  $V_f^H/V_f^D$  in Eq. (7) is given by the ratio of the forward rates of the rate-determining (discharge) step, *i. e.*,

$$V_f^H/V_f^D = v_f^H/v_f^D. \quad (20.f)$$

Similarly we have

$$V_b^H/V_b^D = v_b^H/v_b^D. \quad (20.b)$$

As in the preceding case,  $v_f^H$  is given as<sup>10)</sup>

$$v_f^H/v_b^H = \exp [(\mu_o^{H^+} + \mu^e - \mu^{H(a)})/RT],$$

or on account of the partial equilibrium of the step,  $2H(a) \rightleftharpoons H_2$ , as

$$v_f^H/v_b^H = \exp [(2\mu_o^{H^+} + 2\mu^e - \mu^{H_2})/2RT]. \quad (21.H)$$

Similarly, we have for deuterium

$$v_f^D/v_b^D = \exp [(2\mu_o^{D^+} + 2\mu^e - \mu^{D_2})/2RT]. \quad (21.D)$$

Hence, we have from Eqs. (1. b), (7), (20) and (21)

$$S_{f,o} = Q_{L-G,o} \cdot S_b \cdot \frac{1-X^G}{X^G} \cdot \frac{X_o^G}{1-X_o^G} \exp [(2\mu_o^{H^+} - 2\mu_o^{D^+} - \mu^{H_2} + \mu^{D_2})/2RT], \quad (22)$$

or, using Eqs. (10) and (11) and approximating  $X_o^G/(1-X_o^G)$  as  $m_o^{HD}/2m_o^{H_2}$  as above,

$$S_{f,o} = Q_{L-G,o} \cdot S_b \cdot \frac{1-X^G}{X^G} \cdot \frac{m^{HD}}{2m^{H_2}} \sqrt{\frac{(m_o^{HD})^2}{m_o^{H_2} m_o^{D_2}} \cdot \frac{m^{H_2} m^{D_2}}{(m^{HD})^2}}. \quad (23)$$

This is reduced to

$$S_{f,o} = Q_{L-G,o} \cdot S_b \cdot Z, \quad (24)$$

where

$$Z \equiv \frac{1-X^G}{X^G} \cdot \frac{m^{HD}}{2m^{H_2}} = \frac{2m^{H_2} + m^{HD}}{2m^{D_2} + m^{HD}} \cdot \frac{m^{HD}}{2m^{H_2}} \quad (25)$$

because, as stated above, the hydrogen gas over the electrode T is now always in equilibrium with respect to the reaction (4), *i. e.*, the square root term in Eq. (23) is unity. Thus, the value of  $S_{f,o}$  is determinable from  $S_b$  and the composition of hydrogen gas used in the measurement of  $S_b$ .

Eqs. (24) and (25) indicate that  $S_b$  changes with  $X^G$ , for  $Q_{L-G,o}$  is constant

and  $S_{f,o}$  does not depend on  $X^G$ . It is clear from Eq. (25) that, since the hydrogen is equilibrated, the factor  $Z$  takes the value of unity at  $X^G \simeq 0$ , decreases with increase of  $X^G$  as long as  $K < 4^{*})$  and reaches  $K/4$  at  $X^G \simeq 1$ , *i. e.*,

$$S_{f,o} = Q_{L-G,o} \cdot S_{b,o} \quad (\text{at } X^G \simeq 0) \quad (26)$$

and

$$S_{f,o} = Q_{L-G,o} \cdot S_b \cdot K/4 \quad (\text{at } X^G \simeq 1), \quad (27)$$

where  $K$ , the equilibrium constant of the reaction (4), is to be taken at the experimental temperature. It follows that  $S_b$  increases from  $S_{b,o}$  to  $S_{b,o} \cdot (4/K)$  as  $X^G$  increases from zero to unity.

This variation of  $S_b$  with  $X^G$  can be visualized as follows (in terms of the present example of the slow-discharge mechanism). We define  $\sigma_{12}$  as the relative specific rate of ionization of H(a) to that of D(a), *i. e.*,

$$\sigma_{12} \equiv \frac{v_b^H}{1 - X^A} \bigg/ \frac{v_b^D}{X^A}, \quad (28)$$

and assume it to be constant independent of  $X^A$ , the atomic fraction of deuterium in the adsorbed hydrogen atoms. Then,  $S_b$  in Eq. (1. b) is expressed in terms of  $\sigma_{12}$  using Eqs. (20) and (28) as

$$S_b = \sigma_{12} \cdot \frac{X^G}{1 - X^G} \cdot \frac{1 - X^A}{X^A}. \quad (29)$$

Substituting this into Eq. (24), we have

$$S_{f,o} = Q_{L-G,o} \cdot \sigma_{12} \cdot Z / Q_{A-G}, \quad (30)$$

\*) Using Eq. (15),  $Z$  is expressed as

$$Z = m^{HD}(1 - X^G) / X^G(2 - 2X^G - m^{HD}). \quad (i)$$

Differentiating  $Z$  with  $X^G$ , we have

$$\frac{dZ}{dX^G} = \frac{(m^{HD})^2 - 2(1 - X^G)^2(m^{HD} - X^G \cdot dm^{HD}/dX^G)}{(X^G)^2(2 - 2X^G - m^{HD})^2}. \quad (ii)$$

Here,  $m^{HD}$  is given from Eqs. (15) and  $K = (m^{HD})^2 / m^{H_2} m^{D_2}$  as

$$m^{HD} = [\sqrt{1 + 4(4 - K)(1 - X^G)X^G/K} - 1]K / (4 - K) \quad (iii)$$

(if  $K = 4$ ,  $m^{HD} = 2X^G[1 - X^G]$ ). From Eqs. (ii) and (iii), we have

$$\frac{dZ}{dX^G} = - \frac{8(1 - X^G)^2[1 + 2(4 - K)(1 - X^G)/K - Y]}{Y(Y + 1)^2(2 - 2X^G - m^{HD})^2},$$

where

$$Y \equiv \sqrt{1 + 4(4 - K)(1 - X^G)X^G/K}.$$

$dZ/dX^G$  is shown to be always negative as long as  $K < 4$ .

*Forward and Backward Isotope Separation Factors*

where  $Q_{A-G}$  is the partition coefficient of deuterium between adsorbed hydrogen and hydrogen gas, defined as

$$Q_{A-G} \equiv \left[ \frac{X^A}{1-X^A} / \frac{X^G}{1-X^G} \right]_{\text{eq.}} \quad (31)$$

Similarly, we have from Eq. (26)

$$S_{f,o} = Q_{L-G,o} \cdot \sigma_{12} / Q_{A-G,o} \quad (\text{at } X^G \simeq 0) \quad (32)$$

where  $Q_{A-G,o}$  is the value of  $Q_{A-G}$  at  $X^G = X_o^G$  and  $X^A = X_o^A$ . Consequently, from Eqs. (30) and (32), we obtain

$$Q_{A-G} / Q_{A-G,o} = Z, \quad (33)^*)$$

*i. e.*, as seen above, the ratio decreases as  $X^G$  increases as long as  $K < 4$ , or according to Eq. (31),  $X^A$  does not increase as rapidly as  $X^G$  increases. It follows from Eq. (29) that  $S_b$  increases with increase of  $X^G$ .

### Results of preliminary experiments

Consider the cell set up by connecting solutions of the two half-cells in Fig. 1. The rest potential of the electrode T deviates from that of the reversible hydrogen electrode in the same solution due to the isotope effect in the HER. It has been demonstrated<sup>8)</sup> that, in the case  $\nu = 1$  and when the deuterium-containing hydrogen is equilibrated with respect to the reaction (4), the magnitude of the deviation  $E_r$  (isotopic mixed potential) is related with a sufficient approximation to  $S_b$  and  $X^G$  as

$$\exp(-FE_r/RT) = 1 - X^G + X^G/S_b, \quad (34)$$

and hence  $S_b$  is obtained by measuring  $E_r$  at a given  $X^G$ .

Experiments<sup>\*\*)</sup> have been carried out at 25°C on several systems, all of which are known<sup>7,13,14)</sup> to belong to the case  $\nu = 1$ , using deuterium ( $X^G = 0.997$ ) and hydrogen-deuterium mixture ( $X^G \simeq 0.5$ ) gases which were preliminarily equilibrated on a Pt catalyst heated at about 300°C. Combining two  $S_b$ -values

\*) This relation is not necessarily based on the assumption of the slow-discharge mechanism, but on the adsorption equilibrium of hydrogen. Incidentally, even if we take the *adsorbed* state of hydrogen atom in a metal instead of the *adsorbed* state, we can readily obtain exactly the same form as Eq. (33), *i. e.*,

$$Q_{M-G} / Q_{M-G,o} = Z, \quad (i)$$

where  $Q_{M-G}$  is the partition coefficient of deuterium between *adsorbed* hydrogen and hydrogen gas defined in analogous form as Eq. (31). This relation has previously been implied in a treatment by STACKELBERG.<sup>11)</sup>

\*\*\*) Details of the experiment will be published elsewhere.<sup>12)</sup>

Takamitsu YOKOYAMA and Michio ENYO

TABLE 1. Results on relative specific rate of ionization of H<sub>2</sub> to that of HD ( $\sigma_{23}$ ) and to that of D<sub>2</sub> ( $\sigma_{24}$ ) and deuterium separation factor in the hydrogen evolution reaction from "light" water ( $S_{f,o}$ ), all being near the reversible hydrogen electrode potential. In the last column are given the literature values ( $S_{f,lit.}$ ) observed under cathodic polarization (overpotential is indicated in the parenthesis)

Electrode metal	Solution	$\sigma_{23}$	$\sigma_{24}$	$S_{f,o}$	$S_{f,lit.}$
Ni	0.1N NaOH	1.6 $\pm$ 0.1	2.7 $\pm$ 0.2	6.2	6.7 (0.35 V) <sup>1)</sup>
Pt	0.1N NaOH	1.07 $\pm$ 0.03	1.15 $\pm$ 0.03	4.15	3~4 (<0.1 V) <sup>2)</sup> in 1N H <sub>2</sub> SO <sub>4</sub>
Au	1N H <sub>2</sub> SO <sub>4</sub>	1.0 $\pm$ 0.03	1.25 $\pm$ 0.03	3.87	6.4 (0.35 V) <sup>1)</sup>

thus obtained, both  $\sigma_{23}$  and  $\sigma_{24}$  were evaluated by Eq. (19). These values and  $S_{f,o}$  (all near the reversible hydrogen electrode potential) evaluated by Eq. (16) using  $Q_{L-G,o} = 3.87^{11,15)}$  are given in Table 1; in the last column  $S_{f,lit.}$ , the literature values obtained by direct electrolysis, are listed for comparison.

The  $S_{f,o}$ -value on Ni agrees well with  $S_{f,lit.}$  obtained under a highly cathodic polarization. On Pt,  $S_{f,o}$ -value obtained in an alkaline solution agrees with  $S_{f,lit.}$  which was obtained<sup>2)</sup> near the reversible potential (cathodic overpotential < 0.1 V) in an acidic solution (1N H<sub>2</sub>SO<sub>4</sub>). Since  $S_f$ -value obtained under a highly cathodic polarization is about 7 in alkaline solution,<sup>3)</sup> it follows that  $S_f$  in alkaline solution changes with overpotential as was found in an acidic solution.<sup>2)</sup> A similar dependence of  $S_f$  on overpotential is also expected for Au in acidic solution, where  $S_{f,o}$  is much smaller than  $S_{f,lit.}$  obtained under a cathodic polarization.

#### Acknowledgment

The authors would like to express their gratitude to Professors J. HORIUTI and T. NAKAMURA for their valuable advice.

#### References

- 1) J. HORIUTI and G. OKAMOTO, Sci. Papers Inst. Phys. Chem. Research, Tokyo, **28**, 231 (1936).
- 2) M. FUKUDA and J. HORIUTI, This Journal, **10**, 43 (1962). T. YOKOYAMA, *ibid.*, **15**, 84 (1967).
- 3) H. V. BUTTLAR, W. VIELSTICH and H. BARTH, Ber. Bunsenges. physik. Chem., **67**, 650 (1963).

*Forward and Backward Isotope Separation Factors*

- 4) H. F. WALTON and J. H. WOLFENDEN, *Nature*, **138**, 468 (1936); *Trans. Faraday Soc.*, **34**, 436 (1938). G. P. LEWIS and P. RÜETSCHI, *J. Phys. Chem.* **66**, 1487 (1962). W. VIELSTICH, H. SCHUCHARDT and M. v. STACKELBERG, *Ber. Bunsenges. physik. Chem.*, **67**, 645 (1963). M. SALOMON and B. E. CONWAY, *J. Phys. Chem.*, **68**, 2009 (1964). J. O'M. BOCKRIS and S. SRINIVASAN, *Electrochim. Acta*, **9**, 31 (1964).
- 5) G. OKAMOTO, J. HORIUTI and K. HIROTA, *Sci. Papers Inst. Phys. Chem. Research, Tokyo*, **29**, 223 (1936). J. HORIUTI, T. KEII and K. HIROTA, *This Journal*, **2**, 1 (1951). J. HORIUTI and T. NAKAMURA, *J. Chem. Phys.*, **18**, 395 (1950); *This Journal*, **2**, 73 (1951). T. KEII and T. KODERA, *ibid.*, **5**, 105 (1957). J. O'M. BOKRIS and S. SRINIVASAN, *J. Electrochem. Soc.*, **111**, 844, 853, 858 (1964). B. E. CONWAY and M. SALOMON, *Ber. Bunsenges. physik. Chem.*, **68**, 331 (1964).
- 6) G. P. LEWIS and P. RÜETSCHI, *J. Phys. Chem.*, **67**, 65 (1963). H. LAUER and W. VIELSTICH, *Ber. Bunsenges. physik. Chem.*, **69**, 538 (1965).
- 7) M. ENYO, T. YOKOYAMA and M. HOSHI, *This Journal*, **13**, 222 (1966).
- 8) M. ENYO and T. YOKOYAMA, *Electrochim. Acta*, **12**, 1631, 1641 (1967).
- 9) J. HORIUTI and M. FUKUDA, *This Journal*, **10**, 73 (1962).
- 10) J. HORIUTI. *ibid.*, **1**, 8 (1948). J. HORIUTI and T. NAKAMURA, *Adv. in Catalysis*, **17**, 1 (1967).
- 11) M. v. STACKELBERG and W. JAHNS, *Z. Elektrochem.*, **62**, 349 (1958).
- 12) M. ENYO and T. YOKOYAMA, to be published.
- 13) J. HORIUTI and M. IKUSHIMA, *Proc. Imp. Acad. Tokyo*, **15**, 39 (1939).
- 14) M. ENYO and T. MATSUSHIMA, to be published.
- 15) G. OKAMOTO, *Sci. Papers Inst. Phys. Chem. Research, Tokyo*, **31**, 211 (1937).