



HOKKAIDO UNIVERSITY

Title	THE EFFECT OF SULFUR ON THE ADSORPTION OF HYDROGEN ON MOLYBDENUM
Author(s)	KIKUCHI, Takaharu; ISHIZUKA, Kazuhiko
Citation	JOURNAL OF THE RESEARCH INSTITUTE FOR CATALYSIS HOKKAIDO UNIVERSITY, 26(1), 7-14
Issue Date	1978-07
Doc URL	https://hdl.handle.net/2115/25038
Type	departmental bulletin paper
File Information	26(1)_P7-14.pdf



THE EFFECT OF SULFUR ON THE ADSORPTION OF HYDROGEN ON MOLYBDENUM

By

Takaharu KIKUCHI^{*)} and Kazuhiko ISHIZUKA^{*)}

(Received March 14, 1978)

Abstract

The adsorption of hydrogen on clean and sulfur covered molybdenum is studied by using flash desorption technique combined with field emission microscopy, which permits us to check the cleanliness and the degree of contamination of the surface.

A clean surface of molybdenum, after preadsorption of sulfur from its vapor, is saturated with hydrogen at room temperature, and its flash desorption spectra are recorded. The saturation coverage of hydrogen drops sharply with increasing sulfur coverage up to $S/Mo \approx 1/4$ and then gradually decreases but still holds a high level even at saturation coverage of sulfur. On the other hand, only a very small amount of adsorbed hydrogen is observed on a sulfided surface obtained by heating the sulfur covered surface ($S/Mo \approx 1/2$) at 500°C *in vacuo*. The results indicate that atomic sulfur on molybdenum blocks the sites available for hydrogen adsorption but molecular sulfur does not.

1. Introduction

Recently, the effects of surface compounds or adlayers of oxygen, carbon and sulfur on gas adsorption have been studied on well-defined metal surfaces under ultra high vacuum (UHV) conditions.^{1~10)} Such studies are very important for understanding heterogeneous catalysis including poisoning effects. Despite the fact that sulfurized molybdenum is a practically important catalyst, *e. g.*, for hydrodesulfurisation reactions, the system H_2 -S-Mo has not yet been studied at least under UHV conditions.

This paper describes a study of the behavior of adsorbed hydrogen on sulfur covered molybdenum wires by using flash desorption technique combined with field emission microscopy (FEM), which permits us to check the cleanliness and the degree of contamination of the surface. For comparison, studies on the systems H_2 -Mo and H_2S -Mo are also briefly reported.

^{*)} Research Institute for Catalysis, Hokkaido University, Sapporo, 060 Japan.

2. Experimental

The experiments were performed in a Pyrex glass UHV apparatus providing a base pressure of 3×10^{-10} Torr. An experimental cell, shown schematically in Fig. 1, was designed to allow both flash desorption measurements and FEM observations.

The sample was a partly coiled molybdenum wire (0.03 cm in diameter and 20 cm in length), on which a molybdenum tip was spot-welded. The inner wall of the cell was coated with conducting stannic oxide and in part with willemite phosphor. The sample was heated resistively, and its temperature was measured with a fine W-5% Re/W-26% Re thermocouple spot-welded to the apex of the sample. The thermocouple also served as a sensor for a temperature control circuit, which

provided a linear temperature ramp. A schematic diagram of the circuit is shown in Fig. 2.* The heating rate used for flash desorption experiments was $14^\circ\text{C}/\text{sec}$. Pressure was measured with a Bayard-Alpert ionization gauge and an omegatron type mass spectrometer attached to the cell by a wide bore glass tubing. Observed FEM patterns are shown in Fig. 3 to Fig. 5. The surface was cleaned by prolonged heating (~ 10 hr) at $\sim 2000^\circ\text{C}$ in UHV so that a FEM pattern of clean molybdenum was observed (Fig. 3).

Sulfur was adsorbed by exposing the clean surface to sulfur vapor ($\sim 10^{-8}$ Torr) at room temperature for some time. By changing the exposure time the sulfur coverage θ_s was varied. The θ_s was estimated from the average work function change $\Delta\phi$ caused by sulfur adsorption; *i. e.*, $\Delta\phi$ was computed as the ratio of $\Delta\phi$ to the saturation value of $\Delta\phi$ (1.0 eV). The $\Delta\phi$ was determined from the current voltage characteristics by means of the Fowler-Nordheim plots; for a clean molybdenum surface the average work function

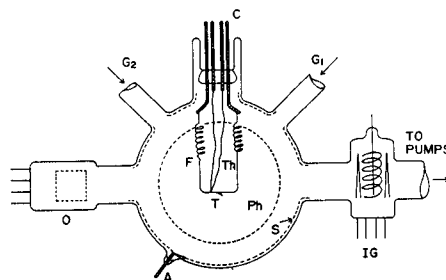

Fig. 1. Schematic diagram of the cell used in this study.

F, Mo-filament; T, Mo-tip; Th, W-5% Re/W-26% Re thermocouple; Ph, willemite phosphor; S, stannic oxide coating; C, cathode lead; A, anode lead; G₁ and G₂, gas inlet; O, omegatron type mass spectrometer; IG, Bayard-Alpert ionization gauge.

* This circuit was designed by the authors with the aid of Dr. S. Sato of this Institute. Although a somewhat similar circuit, designed for a voltage programmable dc supply, has been previously reported by P. Mikonis Jr. and A. K. Green (ref. 11.) the circuit of Fig. 2, using a photo-coupler, has the advantage that it can be used with any raw dc supply and even with an ac source by using a triac system.

The Effect of Sulfur on the Adsorption of Hydrogen on Molybdenum

was taken to be 4.2 eV. The FEM pattern for a surface saturated with sulfur is displayed in Fig. 4, in which it can be seen that adsorbed sulfur is nearly uniformly distributed with some granular appearance over the emitter surface except for high index planes.

Hydrogen and hydrogen sulfide were admitted to the cell for a predetermined time at pressure in the range 10^{-8} to 10^{-7} Torr. After evacuating

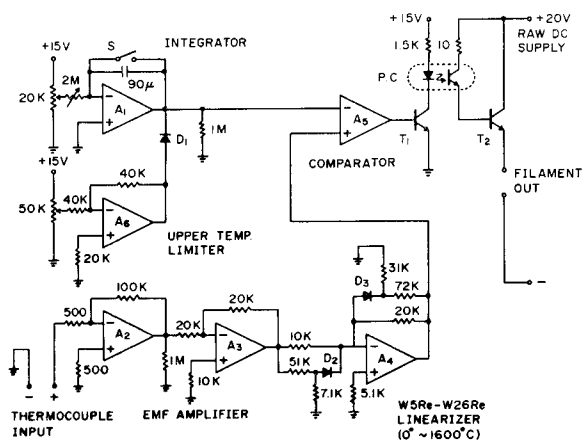

Fig. 2. Schematic diagram of the temperature control circuit.

A₁, A₂, A₃, A₄ and A₅, LM308 H; A₆, LM741 CH; T₁, 2N3568; T₂, 2SD424; D₁, D₂ and D₃, 1S1588; P.C., photocoupler TLP 503; S, sweep switch.

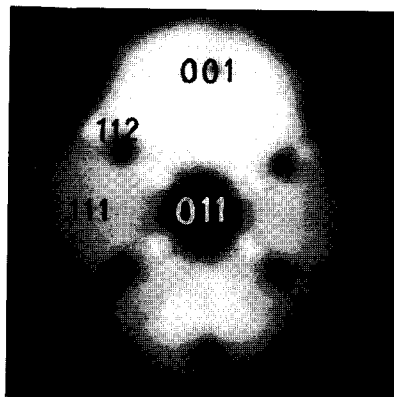

Fig. 3. FEM pattern of clean molybdenum.

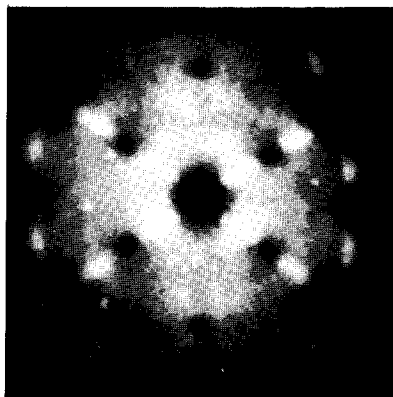

Fig. 4. FEM pattern after sulfur adsorption at room temperature.

the gas to $\sim 10^{-9}$ Torr the sample was flashed, and the variation of partial pressure was recorded.

3. Results and Discussion

A set of flash desorption spectra for hydrogen adsorption on a clean surface of molybdenum at room temperature is shown in Fig. 6. Only one peak appeared in the spectra, which is in accord with the results obtained by Pasternak and Wiesendanger¹²⁾ and Moore and Unterwald.¹³⁾ The amount of adsorbed hydrogen increased with exposures up to 10 L (10×10^{-6} Torr sec), and the peak of spectra shifted to lower temperatures with coverage. An exposure of about 10 L practically lead to saturation, which was estimated to be 7×10^{14} atoms/cm² in good agreement with the value obtained by Pasternak and Wiesendanger.¹²⁾ The peak shift indicates second-order desorption kinetics, and the activation energy was estimated to be ~ 26 kcal/mole.

After preadsorption of sulfur the molybdenum surface was saturated with hydrogen at room temperature, and flash desorption spectra were recorded. The resulting hydrogen saturation spectra as a function of θ_s are presented in Fig. 7. The amount of adsorbed hydrogen decreased with increasing θ_s ; this dependence is displayed in Fig. 8, in which the hydrogen coverage (θ_H) is normalized to the hydrogen saturation coverage of the clean

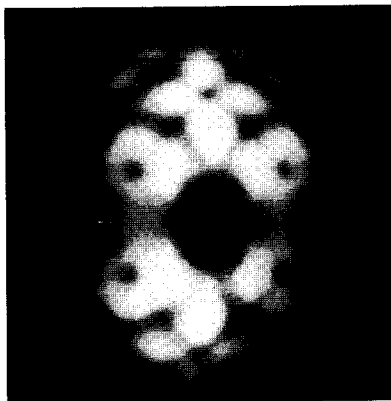

Fig. 5. FEM pattern of sulfided surface.

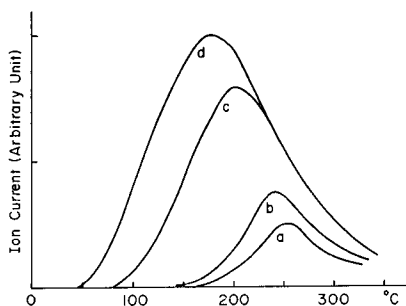

Fig. 6. Flash desorption spectra for hydrogen on a clean surface.
a, 0.1 L; b, 0.3 L; c, 5 L; d, 10 L.

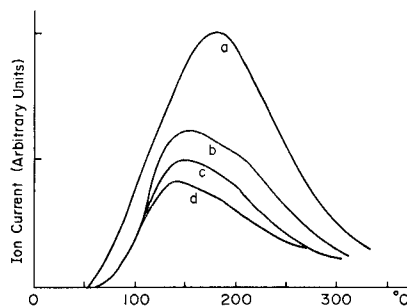

Fig. 7. Hydrogen saturation spectra on sulfur covered surfaces.
a, clean surface; b, $\theta_s=0.5$; c, $\theta_s=1.0$; d, heavy dose.

The Effect of Sulfur on the Adsorption of Hydrogen on Molybdenum

surface. Although the scatter of points in Fig. 8 is rather large, one may see that θ_H drops sharply with increasing θ_S , reaches ~ 0.5 at $\theta_S \approx 0.5$, and then gradually decreases but still holds a high level up to $\theta_S = 1$. When the exposure time (see above) was prolonged further, *i. e.*, when the surface was exposed to sulfur vapor twice as long as time required to attain $\theta_S = 1$, the point \odot in Fig. 8 was reached. The peak at 180°C characteristic of the clean surface shifted to slightly lower temperatures as θ_S became

larger. In addition a shoulder was seen near 200°C . By assuming second-order desorption kinetics, the activation energies for the major peak and the shoulder were estimated to be ~ 22 kcal/mole and ~ 27 kcal/mole respectively. During flash desorption runs hardly any hydrogen sulfide was found in the desorbed gas. The FEM pattern observed after the flashing to $\sim 1000^\circ\text{C}$ was strikingly different from that of the previous surface covered with sulfur, suggesting surface rearrangement or surface compound formation. The clean surface reappeared only after heating the sample above $\sim 1200^\circ\text{C}$ in UHV for a few hours.

On heating the surface covered with sulfur *in vacuo* at 500°C for a short period (~ 2 min) the surface was subjected to drastic changes in structure depending on θ_S as observed by the FEM. The FEM pattern is characterized by anisotropies in the emission (Fig. 5), which can be ascribed to the formation of surface sulfide.¹⁴⁾ The surface sulfide thus formed was very stable up to $\sim 1200^\circ\text{C}$. Fig. 9 gives desorption spectra for saturated hydrogen on the sulfided surfaces. In spite of the remarkable surface change, the features of desorption spectrum for a medium θ_S (curve c) were very similar to those of the sulfur covered surface (Fig. 7, curve b). On the other hand, on the sulfided surface produced by heating the surface heavily dosed with sulfur the amount of adsorbed hydrogen severely reduced down to $\theta_H = 0.08$, and the shoulder disappeared (curve d). In the desorbed gas, hydrogen sulfide was not found perceptibly. After the flashing to $\sim 1000^\circ\text{C}$ the stable FEM pattern due to surface sulfide was still observed as before.

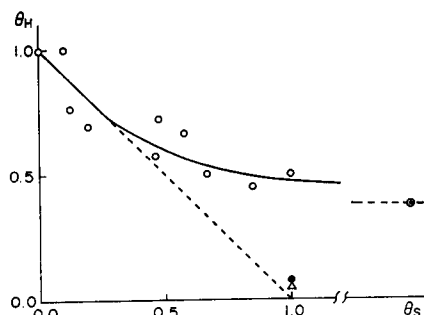

Fig. 8. Normalized saturation coverage of hydrogen as a function of θ_S .

\circ , after preadsorption of sulfur; \bullet , after preheating the surface heavily dosed with sulfur; \triangle , after long time exposure of hydrogen sulfide; \odot , see text.

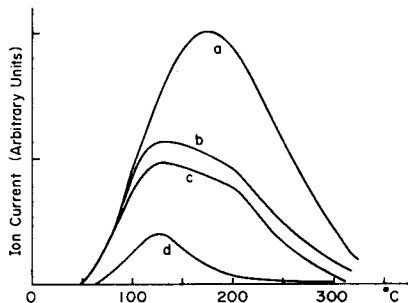

Fig. 9. Hydrogen saturation spectra on sulfided surfaces. a, clean surface; b, $\theta_S=0.22$; c, $\theta_S=0.46$; d, heavy dose.

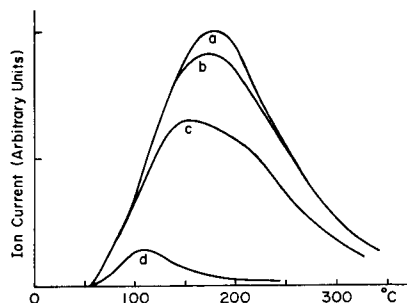

Fig. 10. Flash desorption spectra for hydrogen from hydrogen sulfide on a clean surface. a, clean surface; b and c, some medium exposure; d, long time exposure.

Flash desorption spectra of hydrogen from hydrogen sulfide adsorbed on the clean surface are shown in Fig. 10. The amount of adsorbed hydrogen decreased in order of increasing exposures, of which accurate measurements were not carried out. The results are explained by considering almost complete dissociation of hydrogen sulfide into hydrogen and sulfur and the continuous removal of hydrogen from the surface by incident hydrogen sulfide, leading to gradual accumulation of sulfur on the surface. Long time exposure produced the very reduced spectrum d, where $\theta_H=0.05$, resembled that for adsorbed hydrogen on the sulfided surface obtained after a heavy sulfur dose (Fig. 9, curve d). Moreover, the characteristic spectrum for hydrogen on the sulfur covered surface (Fig. 7, curve b) was also reproduced by some exposure suitable for a medium sulfur coverage (curve c). Spectra nearly indistinguishable from the above were also found after exposing the surface treated with hydrogen sulfide to hydrogen. These results further confirm that hydrogen sulfide decomposes on the clean molybdenum surface at room temperature. A trace of hydrogen sulfide was detected in the desorbed gas during flashing runs.

We now consider how θ_S as determined from $\Delta\phi$ corresponds to the atomic S/Mo ratio to clarify the blocking effect of sulfur on hydrogen adsorption. Although a direct measurement is not possible, recent low energy electron diffraction (LEED) and Auger studies of sulfur adsorption on transition metals including molybdenum indicate that the graph of Fig. 8 can be used to estimate the adsorbed states of sulfur and the S/Mo ratio. Wilson¹⁵⁾ has rationalized a saturation value of sulfur of half a monolayer (S/Mo=1/2) on Mo (100) and (111) planes saturated with hydrogen sulfide at room tem-

The Effect of Sulfur on the Adsorption of Hydrogen on Molybdenum

perature. Heegemann *et al.*¹⁶⁾ have also observed sulfur overlayers limited to half a monolayer with a $c(2 \times 2)$ LEED pattern on Pt(100) and (111) planes at room temperature, using a molecular beam of S_2 generated by electrochemical decomposition of Ag_2S . With sulfur vapor (mainly composed of S_8) as the source of sulfur, Legg and Jona¹⁷⁾ have found that in an early stage of its adsorption on a Fe(100) plane at room temperature, the sulfur atoms are ordered on the surface, producing a $c(2 \times 2)$ structure.

Thus, the very reduced hydrogen uptake ($\theta_H=0.05$) observed on the surface treated with hydrogen sulfide for a long time (Fig. 8, triangle) suggests that half a monolayer of sulfur atoms blocks almost all of the sites available for hydrogen adsorption. The extension of the initial segment of the θ_H vs. θ_S curve in Fig. 8 intersects the abscissa at $\theta_S=1$; if we assume that complete dissociation of sulfur molecules does occur at least in the first stage of its adsorption and one sulfur atom blocks two hydrogen atoms on the average, the intersection corresponds to $S/Mo=1/2$. On the contrary, a considerable amount of hydrogen uptake is observed on the sulfur covered surface over the wide range of sulfur coverage up to $\theta_S=1$ as seen in Fig. 8; this may be attributed to an open structure caused by molecular adsorption of sulfur as will be shown later. After preheating the surface heavily dosed with sulfur θ_H falls down to 0.08 (Fig. 8, closed circle), indicating substantial saturation due to sulfur atoms produced by dissociation of molecular sulfur at elevated temperature. (We referred to such a heat-treated surface as "sulfided surface" in a previous paragraph.) Here it is interesting to note that an entirely similar blocking effect of sulfur has been found by Bonzel and Ku⁴⁾ in the system CO-S-Pt(100) plane: They showed that sulfur occupies two surface sites as long as the total coverage is small.

Nearly constant hydrogen uptake ($\theta_H \simeq 0.5$) over the wide range of sulfur coverages higher than $\theta_S \simeq 0.5$ indicates that about one-half of the total sites available for hydrogen adsorption remains almost regardless of the amount of sulfur. One of possible explanations of this behavior is as follows. The adsorption of sulfur from its vapor first occurs dissociatively forming an atomic layer on the clean surface up to $S/Mo \simeq 1/4$. Adsorbed sulfur atoms simply block the sites available for hydrogen adsorption as remarked in the preceding paragraph. Further exposure to sulfur vapor beyond $S/Mo \simeq 1/4$ sulfur molecules are adsorbed non-dissociatively keeping their octagonal ring structure, whose dimension is many times larger than the substrate interatomic distance. (Also, in an intermediate θ_S range partially dissociative adsorption of sulfur should occur.) Such a sulfur layer causes an open structure permitting adsorbed hydrogen to migrate freely seeking vacant sites.

T. KIKUCHI and K. ISHIZUKA

This layer does not block effectively the sites available for hydrogen adsorption, thus supporting the experimental observation of nearly constant hydrogen uptake at higher θ_s .

The similarities of the hydrogen desorption spectra from the sulfur covered surface and the sulfided surface both in a medium θ_s range, and from hydrogen sulfide on the clean surface, were rather unexpected findings because the FEM patterns indicated that these surfaces were clearly different. This fact suggests that the adsorption energy of hydrogen is practically unaffected by the adsorbed states of sulfur regardless of whether adsorbed sulfur is molecular or atomic. The appearance of the shoulder on those spectra apparently shows two different binding states of hydrogen; this may be interpreted by a special interaction of hydrogen with sulfur and/or sulfur induced heterogeneity as suggested by several authors.^{1~4,9)}

Acknowledgement

The authors wish to express their sincere thanks to Professor Katsuhiko Azuma for helpful discussions and to Professor Takashi Nakamura for a critical reading of the manuscript.

References

- 1) D. L. Adams, L. H. Germer and J. W. May, *Surface Sci.*, **22**, 45 (1970).
- 2) T. E. Madey, *Surface Sci.*, **29**, 571 (1972).
- 3) C. G. Goymour and D. A. King, *Surface Sci.*, **35**, 246 (1973).
- 4) H. P. Bonzel and R. Ku, *J. Chem. Phys.*, **58**, 4617 (1973).
- 5) F. P. Netzer and G. Kneringer, *Surface Sci.*, **51**, 526 (1975).
- 6) R. Ducros, J. J. Ehrhardt, M. Alnot and A. Cassuto, *Surface Sci.*, **55**, 509 (1976).
- 7) J. G. McCarty and R. J. Madix, *Surface Sci.*, **54**, 121 (1976).
- 8) B. J. Hopkins and G. D. Watts, *Surface Sci.*, **55**, 729 (1976).
- 9) R. W. McCabe and L. D. Schmidt, *Surface Sci.*, **60**, 85 (1976).
- 10) R. W. McCabe and L. D. Schmidt, *Surface Sci.*, **65**, 85 (1977).
- 11) P. Mikonis Jr. and A. K. Green, *J. Vac. Sci. Technol.*, **11**, 849 (1974).
- 12) R. A. Pasternak and U. D. Wiesendanger, *J. Chem. Phys.*, **34**, 2062 (1961).
- 13) G. E. Moore and F. C. Unterwald, *J. Chem. Phys.*, **40**, 2626 (1964).
- 14) K. Ishizuka, *The Second Japan-Soviet Catalysis Seminar*, Tokyo (1973), p. 111.
- 15) J. W. Wilson, *Surface Sci.*, **53**, 330 (1975); **59**, 315 (1976).
- 16) W. Heegemann, K. H. Meister, E. Bechtold and K. Hayek, *Surface Sci.*, **49**, 161 (1975).
- 17) K. O. Legg and F. Jona, *Surface Sci.*, **66**, 25 (1977).