



# HOKKAIDO UNIVERSITY

Title	AMMONIA SYNTHESIS ON SURFACE LAYERS OF MOLYBDENUM NITRIDE
Author(s)	OYAMA, S. T.; BOUDART, M.
Citation	JOURNAL OF THE RESEARCH INSTITUTE FOR CATALYSIS HOKKAIDO UNIVERSITY, 28(3), 305-320
Issue Date	1981-06
Doc URL	<a href="https://hdl.handle.net/2115/25100">https://hdl.handle.net/2115/25100</a>
Type	departmental bulletin paper
File Information	28(3)_P305-320.pdf



## AMMONIA SYNTHESIS ON SURFACE LAYERS OF MOLYBDENUM NITRIDE

By

S. T. OYAMA\*<sup>1)</sup> and M. BOUDART\*<sup>2)</sup>

(Received December 8, 1980)

### Abstract

The rate of ammonia synthesis on molybdenum Mo and its interstitial alloys, molybdenum carbide  $\text{Mo}_2\text{C}$  and oxycarbide  $\text{MoO}_x\text{C}_y$  was measured in a flow system with simultaneous gravimetric determination of the nitrogen uptake of the catalysts. On prereduced  $\text{Mo}_2\text{C}$  and  $\text{MoO}_x\text{C}_y$  the activity went up with time and reached a steady-state value when the catalyst had taken up about one monolayer of nitrogen, corresponding to a stoichiometry of MoN. On Mo the steady-state was reached after take-up of the same monolayer of MoN plus two layers of  $\text{Mo}_2\text{N}$ . In all three cases the steady-state rates were found to be very similar. The small amounts of N taken up to reach similar rates suggest that the catalysis on metals involves localized surface orbitals.

### Introduction

Many studies<sup>1-12)</sup> in solid state physics have attempted to determine the distance away from a surface necessary for the properties of a metal to reach their bulk values. The properties considered are those depending on the distribution of electronic charge or density of states. The main conclusion for simple and *d*-band metals is that surface electronic wave functions become rapidly extinguished away from the surface. The decay involves at most a few atomic distances.

In contrast to these theoretical studies, it was concluded in a number of catalytic investigations that the catalytic activity of metal surfaces is influenced by a large number of subsurface layers. We shall restrict our attention to molybdenum metal and its interstitial alloys, molybdenum nitride, carbide, and oxycarbide.

In their ammonia synthesis work on a molybdenum foil, Moore and Unterwald<sup>13-15)</sup> suggest the participation of about 400 atomic layers below the surface so that "widely accepted models for catalysis must be reconsidered". The results of Moore and Unterwald are in fact complicated by the solution of nitrogen into the bulk of the metal. For example, the re-

\* Department of Chemical Engineering, Stanford University, Stanford, Ca. 94305, USA.

ported persistence of ammonia synthesis activity in hydrogen after the nitrogen supply is cut off can be explained by a rapid equilibration between subsurface layers of nitride and surface nitrogen. Indeed, Aika and Ozaki<sup>16)</sup> who studied ammonia synthesis on a molybdenum powder demonstrated this phenomenon by the use of isotopically traced nitrogen.

With respect to the question as to how many layers of subsurface nitrogen are required for reaching asymptotic values for the reactivity of surface nitrogen, Tsuchiya and Ozaki<sup>17)</sup> measured the rate of hydrogenation of nitrogen presorbed on a molybdenum powder and found that the rate rose with presorbed amount until the amount was 11 times the monolayer value and then reached a constant value. The monolayer value was taken to be that given by a BET measurement.

In a related earlier study of ammonia decomposition on tungsten Tamaru reported that surface nitride layers of several layers thickness are formed.<sup>18)</sup> From his data about 3 to 4 layers can be calculated, one layer consisting of one nitrogen atom for two tungsten atoms. Tamaru finds that as the nitride layers become thicker the rate of nitriding decreases whereas the rate of nitrogen desorption increases. In this work where 112 g of catalyst were used, as well as in the work of Tsuchiya and Ozaki where 40 g were used, the catalysts were packed into sizable beds and the usual concentration gradients associated with such beds are expected to exist. Because of these gradients the amount of nitrogen taken up by the bed will not be uniform, as the uptake may be larger at the entrance than at the exit of the reactor. Because of this the average take-up may be overestimated. Even when only 1 g of catalyst is used this "bed effect" may appear as indicated by a recent study by Boudart *et al.*,<sup>19)</sup> whose results will be compared with those of the present work. Boudart *et al.* found that the steady-state rate of ammonia synthesis on a molybdenum powder was reached after the catalyst had taken up nitrogen corresponding to 4 or 5 layers assumed to consist of  $\text{Mo}_2\text{N}$ . The amount of nitrogen was determined by flowing hydrogen over the catalyst bed and measuring the amount of ammonia produced. That the nitrogen was in the form of a thin layer of surface nitride was inferred from the x-ray diffraction pattern of the powder which showed only the lines characteristic of Mo metal. The phase diagram indicates that little dissolution of N into the bulk of the molybdenum occurs at the temperature of investigation. This was confirmed by measurement of the lattice parameter which showed no lattice expansion. The remarkable fact was that the activity of this surface nitride was very nearly the same as that of a bulk molybdenum nitride (*fcc*). Furthermore, the activity was very close

*Ammonia Synthesis on Molybdenum Nitride*

to that of a bulk molybdenum carbide (*hex*) and to that of a bulk molybdenum oxycarbide (*fcc*). The activity is a site time yield (STY) defined as the number of ammonia molecules at reactor exit produced per second per surface site in the reactor. The surface sites were titrated by the irreversible chemisorption of CO at room temperature after reaction with the assumed ratio of one site per CO molecule. On the molybdenum carbide the amount of nitrogen assimilated by the catalyst corresponded to 1 monolayer of  $\text{Mo}_2\text{N}$ .

When measurements of the initial rate of reaction were taken it was found that on the carbide and oxycarbide the rates approached steady-state quickly, but on the plain molybdenum a longer induction period was observed (19). On the carbide which only required 1 monolayer of nitride  $\text{Mo}_2\text{N}$  the steady-state was reached when the layer was completed. On the plain molybdenum, which required 4 to 5 monolayers of  $\text{Mo}_2\text{N}$ , the ammonia produced at the beginning of the bed may have been used to nitride the catalyst further down the bed. Thus, there is a possibility that "breakthrough" in ammonia yield occurred only after the entire bed had been nitrified to an average extent larger than necessary for steady-state behavior. Thus, even in these experiments in which the amount of catalyst was only 1 g, an effect due to the presence of the bed could have been observed.

Thus, as seen above there seems to be considerable disagreement as to the number of sub-surface layers required to obtain asymptotic surface properties. We have undertaken the following study in order to clarify the issue by avoiding "bed effects." The system investigated, the Mo-N system in ammonia synthesis, is particularly suited for this purpose because molybdenum slowly nitrifies during ammonia synthesis. In this system it is therefore possible to monitor surface reactivity as a function of nitrogen uptake as measured gravimetrically.

Part of the conflicting results may be ascribed to different definitions of a monolayer. It is important to clarify now what will be meant by a monolayer. In the case of single crystals, layers are defined as the consecutive planes parallel to the surface. In the case of polycrystalline samples the situation is more complex for different planes are exposed, but to a first approximation an average over the low index planes can be taken. In the present work the nitrogen uptake is expressed as  $\theta$  which is defined as the number of layers of surface nitride determined by taking the ratio of the measured nitrogen uptake per  $\text{cm}^2$  of total BET surface area to the assumed nitrogen monolayer atom density of  $1.0 \times 10^{15} \text{cm}^{-2}$ . If equal areas of the low index (100), (110), (111), and (210) planes are exposed the molybdenum monolayer density would be  $0.95 \times 10^{15} \text{cm}^{-2}$ . Matsushita and Hansen<sup>20</sup> in

their low pressure work on ammonia decomposition over a polycrystalline molybdenum foil have found at high exposures of nitrogen a  $(\beta+x)$  structure similar to that found for tungsten. The stoichiometry of this nitrogen layer is one nitrogen atom per surface metal atom, thus, for the topmost layer a density of  $1.0 \times 10^{15} \text{ cm}^{-2}$  is justified. For lower layers, if there is formation of a  $\text{Mo}_2\text{N}$  phase, the density will be one half this value and this will be assumed in subsequent discussions of the number of nitrogen layers taken up.

In the previous work,<sup>19</sup> due to the inclusion of higher order planes (211) and (221), the average density of N atoms for the  $\text{Mo}_2\text{N}$  stoichiometry was higher:  $0.38 \times 10^{16} \text{ atoms cm}^{-2}$ . Also, as will be discussed later, in the previous work the surface areas were measured volumetrically which gave values of the surface area 20% larger than those measured gravimetrically. When this is taken into account the value of the density for  $\text{Mo}_2\text{N}$  rises to  $1.0 \times 10^{15} \text{ cm}^{-2}$ , which is the value of the density of  $\text{MoN}$  in the present work. Thus, in the discussion of the previous work layers of " $\text{Mo}_2\text{N}$ " should be considered as layers of " $\text{MoN}$ ".

### Experimental

The investigation was carried out using powders of molybdenum, molyb-

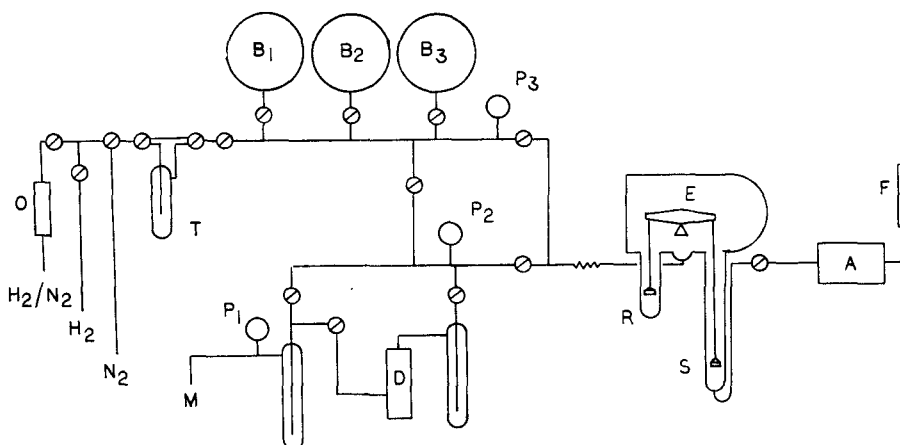

Fig. 1. Schematic Diagram of the Gravimetric Apparatus.

E-Cahn Model RG 2000 gravimetric electrobalance, R-Reference weights, S-Sample basket, A-Beckman Model 865 NDIR ammonia analyzer, F-Flowmeter, B<sub>1</sub>-B<sub>3</sub>-Gas delivery bulbs, O-Deoxo purifier, T-Linde 5 A molecular sieve trap, M-Mechanical pump, D-Diffusion pump, P<sub>1</sub>-Thermocouple gauge, P<sub>2</sub>-Ionization gauge, P<sub>3</sub>-Wallace and Tiernan gauge.

*Ammonia Synthesis on Molybdenum Nitride*

denum carbide, oxycarbide, and nitride, formerly called Mo-2, Mo<sub>2</sub>C-2, MoO<sub>x</sub>C<sub>y</sub>-2, and Mo<sub>2</sub>N-1,<sup>19)</sup> and designated here as Mo-2, Mo<sub>2</sub>C, MoO<sub>x</sub>C<sub>y</sub>, and Mo<sub>2</sub>N, respectively. The molybdenum sample used in this work labelled Mo-1 was prepared by the batch reduction of high purity MoO<sub>3</sub> (Puratronic 99.9998%) supplied by Johnson Matthey Chemicals Limited. The reduction was carried out for 88 h in flowing Pd-diffused H<sub>2</sub> at 773 K at a space velocity based on bed volume of 14000 h<sup>-1</sup> and was followed by passivation at room temperature in helium containing 1% O<sub>2</sub>, as previously done for the other samples.<sup>19)</sup>

The apparatus used is shown schematically in Fig. 1. The maximum load of the gravimetric balance is 1 g with a sensitivity of  $1.0 \times 10^{-6}$  g. Typically 0.1 g of catalyst which had been compacted at 60 MPa in a hydraulic press was used to avoid forming a catalyst bed. The system could be evacuated down to 10<sup>-4</sup> Pa. Hydrogen, purified by diffusion through Pd, was supplied by an ElHygen generator. A stoichiometric H<sub>2</sub>/N<sub>2</sub> mixture obtained from the Matheson Company was purified by passage through an Engelhard Deoxo unit (O) and a Linde 5 A molecular sieve trap (T) cooled by liquid nitrogen. The bulbs (B) were designed to provide large amounts of gas to the evacuated balance when switching from one gas to another and so to avoid delay times.

Gas pressure was monitored by a thermocouple gauge (P<sub>1</sub>), an ionization gauge (P<sub>2</sub>), and a Wallace and Tiernan absolute pressure gauge (P<sub>3</sub>) to measure pressures between 1 and 110 kPa after calibration with a McLeod gauge.

For analysis we used a Beckman Model 865 NDIR high sensitivity infrared ammonia analyzer (A) capable of detecting 3-3500 ppm ammonia. The detector was calibrated by NH<sub>3</sub>/He calibrating standards supplied by the Matheson Company which in turn were checked by titrating a standard solution of acid through which a known volume of the gas had been passed. The output from the gravimetric balance and the detector were recorded continuously on chart recorders.

The sample bucket hangdown tube was designed according to Cutting<sup>21)</sup> so as to permit the measurement of reaction rates at high temperatures (773 K) and of nitrogen adsorption isotherms at 77 K. A Chromel-Alumel thermocouple, specially insulated so as to prevent heat conduction to the sample was sealed inside the tube. The thermocouple junction rested 1 cm below the catalyst basket.

The microbalance was calibrated by using a piece of gold foil (Marz gold) supplied by the Materials Research Corporation of the same volume as the catalysts subsequently studied. Weight correction curves for changes

in temperature, flow rate, and pressure were determined following the work of Scholten.<sup>22)</sup> Lag times due to flow from reactor to detector were also measured and taken into account. Together with weight corrections, they are presented in detail elsewhere.<sup>23)</sup>

The catalysts were pretreated by evacuation to  $10^{-4}$  Pa for 24 h followed by reduction for 8 h in flowing hydrogen at space velocities based on catalyst volume of  $30,000 \text{ h}^{-1}$ . The temperature of reduction was 773 K for the molybdenum and 683 K for the carbide and oxycarbide. At the end of the reduction the weights of the catalysts reached a steady value. The reduction was followed by brief evacuation to 1 Pa and switching to a purified  $\text{H}_2/\text{N}_2$  flow. The switching was accomplished by flowing the contents of two of the ballast bulbs (pressurized so as to bring the gravimetric balance to atmospheric pressure) followed by passage of the  $\text{H}_2/\text{N}_2$  mixture originating from a cylinder. The entire process took about 60 s.

### Results

In Table 1 are shown the effects on the weight of the catalysts of the pretreatments described previously. The weight losses during evacuation and reduction are presented as due to the loss by the catalysts of equivalent amounts of water molecules and oxygen atoms, respectively. The amounts are given per surface area as measured gravimetrically *in situ* after ammonia synthesis.

The nitrogen uptake during reduction could be followed directly by monitoring the weight increase of the catalyst. For  $\text{Mo}_2\text{C}$  and  $\text{MoO}_x\text{C}_y$  the weight changes were not unambiguous for the changes could mask the loss of C and O. However, in separate experiments it was determined that for the  $\text{Mo}_2\text{C}$  carbon loss due to methane or higher hydrocarbons as measured by IR was negligible below 723 K. For  $\text{MoO}_x\text{C}_y$  the catalyst weight remained constant in  $\text{H}_2$  flow at 723 K, indicating that no oxygen or carbon

TABLE 1. Weight Changes During Evacuation and Reduction

Catalyst	Weight g	Gravimetric BET area $\text{m}^2 \text{g}^{-1}$	Weight loss during evacuation mg	Equivalent water take-up $10^{15} \text{ cm}^{-2}$	Weight loss during reduction mg	Equivalent oxygen take-up $10^{15} \text{ cm}^{-2}$
Mo-1	0.1114	4.0	0.619	4.6	0.671	5.7
$\text{Mo}_2\text{C}$	0.1363	8.5	1.478	4.3	4.220	13.7
$\text{MoO}_x\text{C}_y$	0.0914	27.7	5.230	6.9	8.392	12.5

*Ammonia Synthesis on Molybdenum Nitride*

was being lost.

The physical properties of the catalyst have been reported previously. Table 2 presents the density of surface atoms of the various catalysts calculated from chemisorption and physisorption data obtained with a volumetric apparatus. The surface atoms were titrated by the irreversible chemisorption of hydrogen or carbon monoxide at room temperature. The amount of irreversibly adsorbed gas was taken to be that given by the difference between the total adsorbed and backsorbed amounts. These amounts were found by extrapolation to zero pressure of the linear section of the total adsorption and back sorption isotherms. It was assumed that dissociation of H<sub>2</sub> occurred but no dissociation of CO.

The surface areas were measured both gravimetrically and volumetrically by the physisorption of N<sub>2</sub> at liquid nitrogen temperatures, the BET method. As can be seen by comparing Tables 1 and 2, the volumetric surface areas were about 20% larger than the gravimetric surface areas. Since this was on different samples of the same material which had been treated in similar

TABLE 2. Density of Surface Atoms by H<sub>2</sub> and CO Chemisorption

Catalyst	Volumetric BET area m <sup>2</sup> g <sup>-1</sup>	H <sub>2</sub> uptake μmol g <sup>-1</sup>	CO uptake μmol g <sup>-1</sup>	Density of Surface Atoms	
				Density by atomic H 10 <sup>15</sup> cm <sup>-2</sup>	Density by molec. CO 10 <sup>15</sup> cm <sup>-2</sup>
Mo-1	5 <sup>b)</sup>	11 <sup>b)</sup>	23 <sup>b)</sup>	0.25	0.27
Mo-2	18 <sup>b)</sup>	9 <sup>b)</sup>	18 <sup>b)</sup>	0.06	0.06
Mo <sub>2</sub> C	11 <sup>a)</sup>	—	46 <sup>a)</sup>	—	0.25
Mo <sub>2</sub> N	12 <sup>a)</sup>	—	25 <sup>a)</sup>	—	0.13
MoO <sub>x</sub> C <sub>y</sub>	30 <sup>a)</sup>	—	68 <sup>a)</sup>	—	0.14

a) After ammonia synthesis    b) Before ammonia synthesis

TABLE 3. Ammonia Synthesis: Steady-State Site Time Yield, STY

Catalyst	Weight Time Yield 10 <sup>-7</sup> mol g <sup>-1</sup> s <sup>-1</sup>	STY	
		Present work ks <sup>-1</sup>	Past work (19) ks <sup>-1</sup>
Mo <sub>2</sub> C	1.8	3.9 (683 K)	6.5 (673 K)
MoO <sub>x</sub> C <sub>y</sub>	1.3	1.9 (685 K)	2.7 (673 K)
Mo-1	0.29	1.3 (674 K)	—
Mo <sub>2</sub> N	—	—	2.4 (675 K)

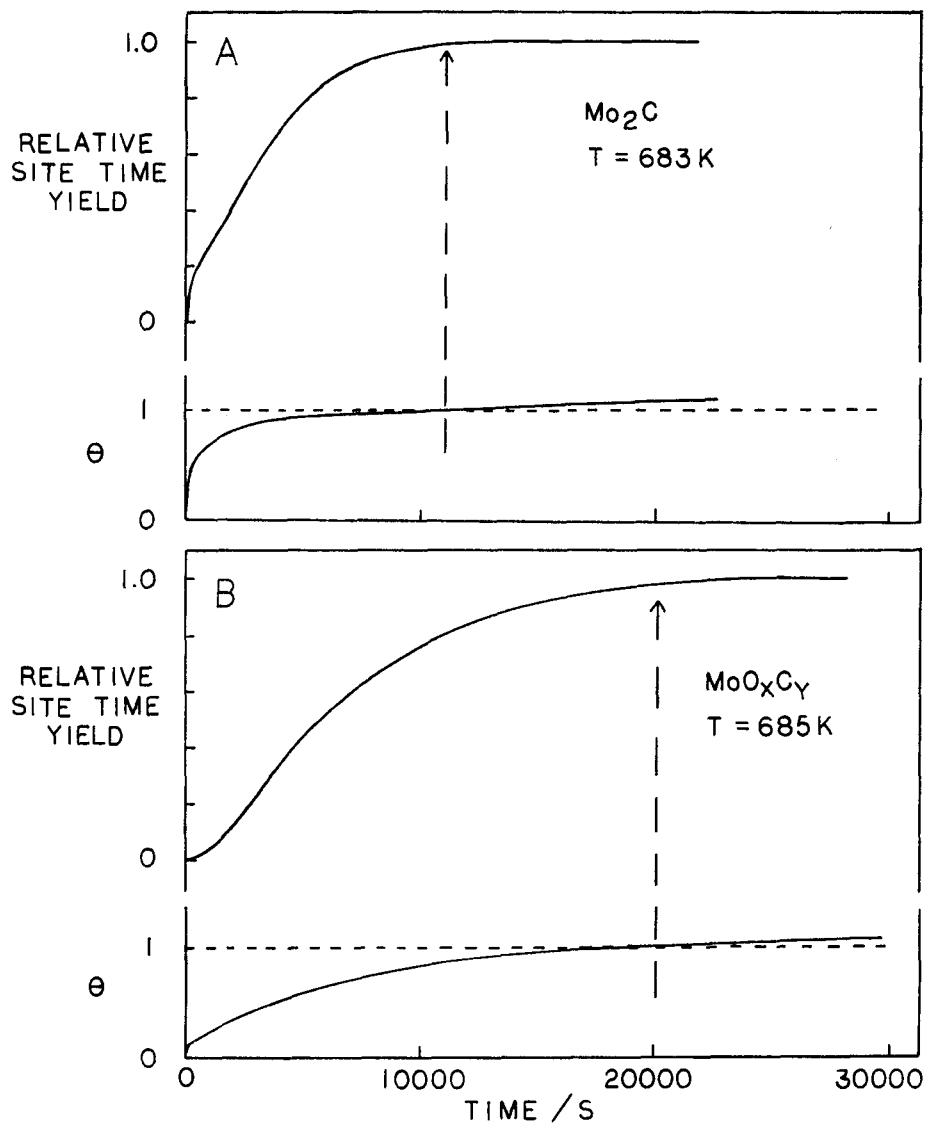

**Fig. 2.** Nitrogen Uptake During the Initial Stages of Ammonia Synthesis. Rates are expressed as site time yields normalized to the steady-state rate. Monolayer coverage,  $\theta = 1.0$  defined as  $1.0 \times 10^{15}$  nitrogen atoms per  $\text{cm}^2$ .

A.  $\text{Mo}_2\text{C}$ , weight 0.1363 g, flow rate  $2.80 \text{ cm}^3 \text{ s}^{-1}$ ,  $T = 638 \text{ K}$

B.  $\text{MoO}_x\text{C}_y$ , weight 0.0914 g, flow rate  $2.38 \text{ cm}^3 \text{ s}^{-1}$ ,  $T = 685 \text{ K}$ .

*Ammonia Synthesis on Molybdenum Nitride*

manners, the difference was probably due to insufficient temperature equilibration in the gravimetric method.

Values of steady-state STY are presented in Table 3, where they are compared to those obtained previously.<sup>19)</sup> As before it was assumed that one site corresponded to each CO molecule adsorbed.

The results for the rate of the reaction are shown in Figs. 2 and 3. They are displayed as relative site time yields, yields normalized to their corresponding steady-state yields. The weight uptakes duly corrected for buoyancy and Poiseuille forces are shown below each of the transients. They are given in terms of monolayer equivalents defined as  $1.0 \times 10^{15}$  N atoms per  $\text{cm}^2$  (MoN stoichiometry) and are based on the nitrogen BET surface areas measured *in situ* after reaction.

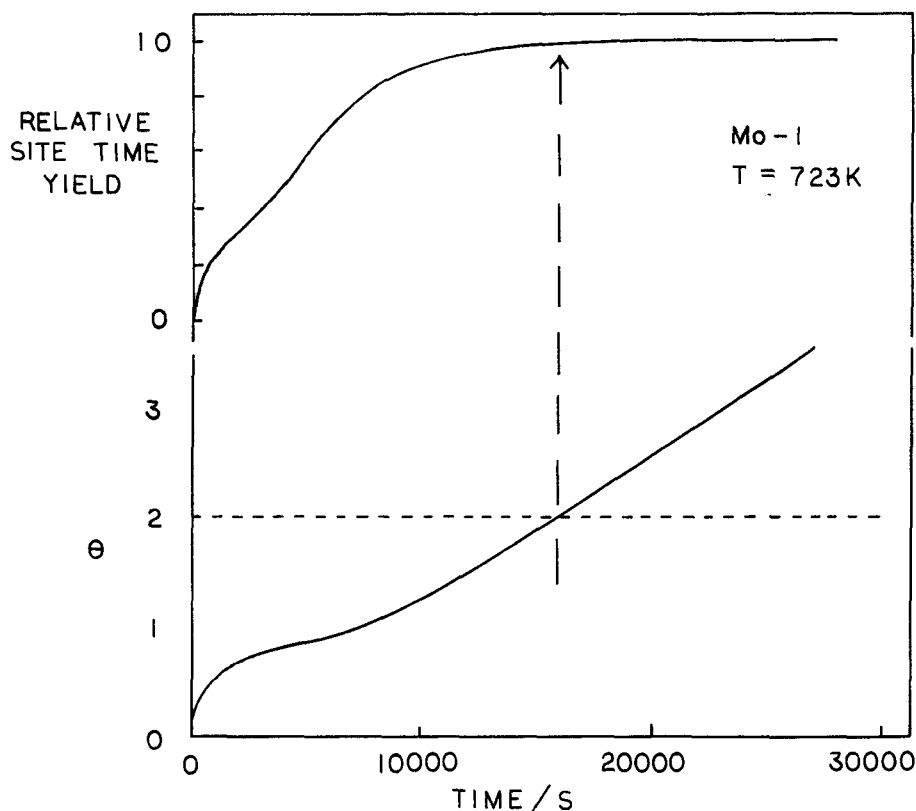

**Fig. 3.** Nitrogen Uptake During the Initial Stages of Ammonia Synthesis. Rate is expressed as site time yield normalized to the steady-state rate. Monolayer coverage,  $\theta = 1.0$  defined as  $1.0 \times 10^{15}$  nitrogen atoms per  $\text{cm}^2$ .

Mo-1, weight 0.1114 g, flow rate  $2.67 \text{ cm}^3 \text{ s}^{-1}$ ,  $T = 723 \text{ K}$ .

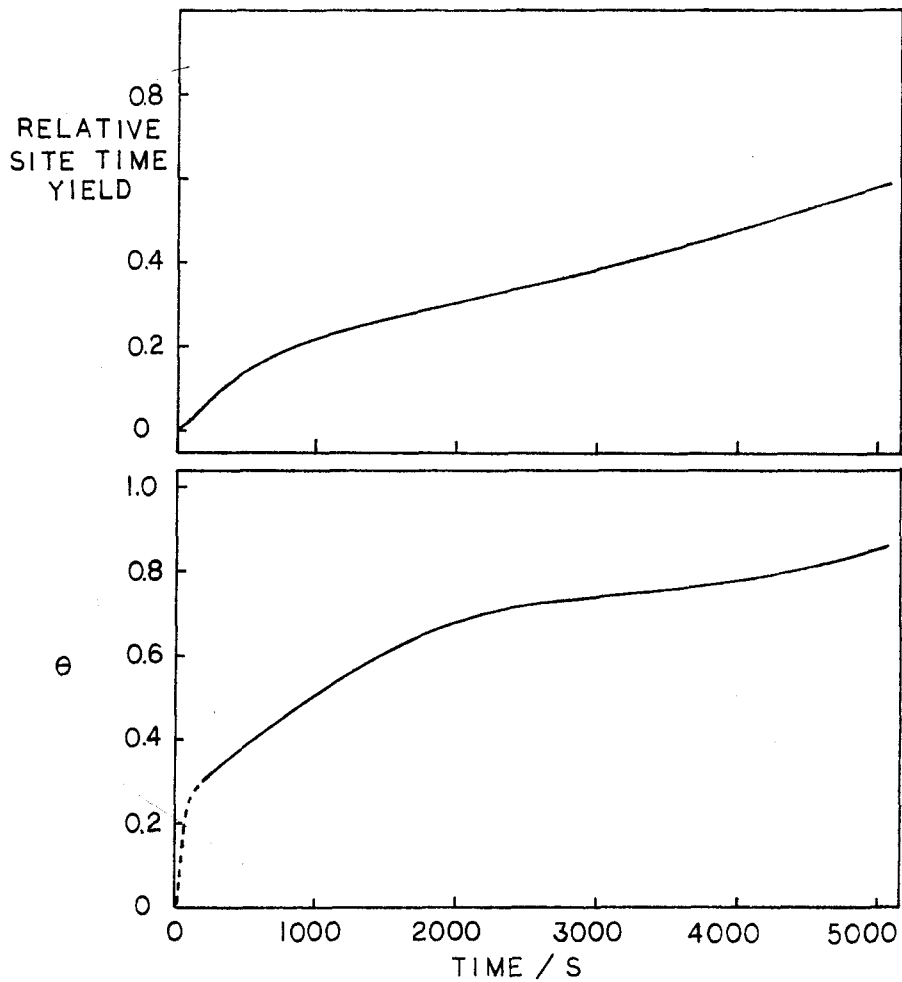
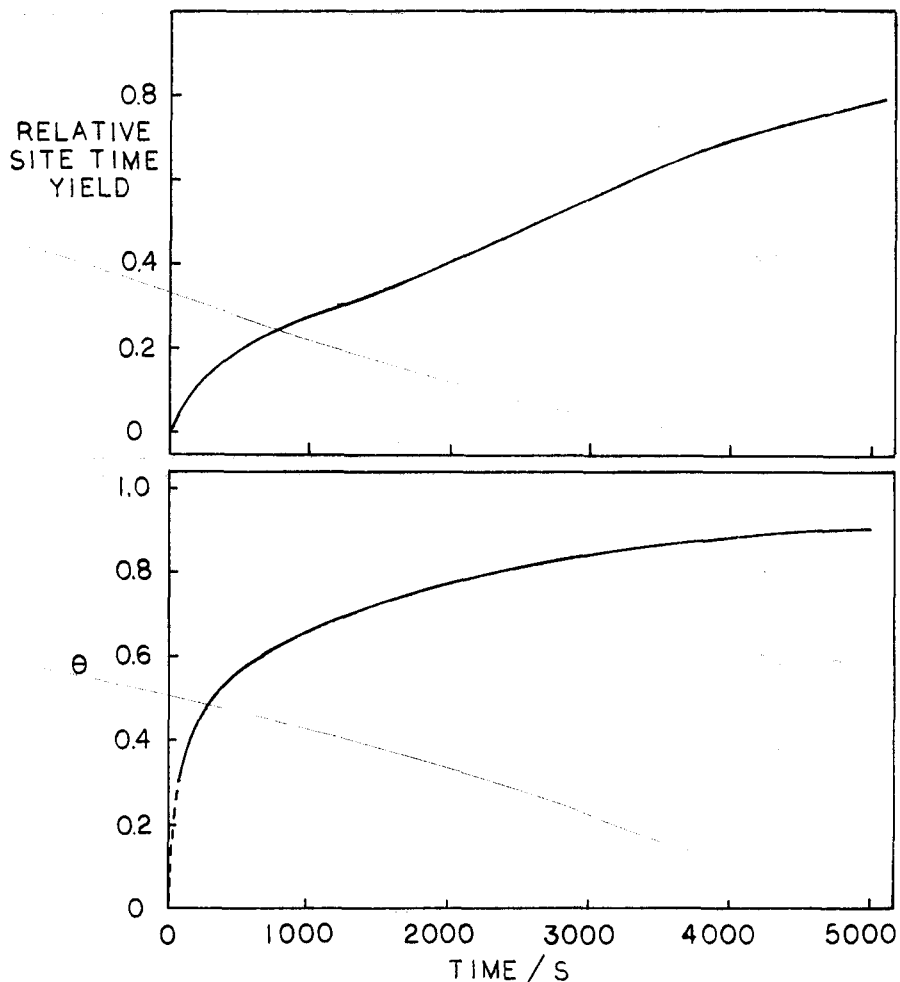

Fig. 4. Onset of the Activity and Nitrogen Uptake: Mo-1. Conditions same as in Fig. 3.

As can be seen on  $\text{Mo}_2\text{C}$  and  $\text{MoO}_x\text{C}_y$  the activity reaches a steady-state just as one monolayer equivalent is reached. On plain Mo, however, the activity reaches steady-state after two monolayer equivalents are formed, or three if second and subsequent layers are assumed to have the  $\text{Mo}_2\text{N}$

*Ammonia Synthesis on Molybdenum Nitride*



**Fig. 5.** Onset of the Activity and Nitrogen Uptake: MoC. Conditions same as in Fig. 2 A.

stoichiometry of the bulk. The rate then remains constant even though nitrogen uptake continues steadily at a rate equal to about one tenth that of ammonia synthesis. In Figs. 4-6 are shown expanded versions of the initial portions of the same data.

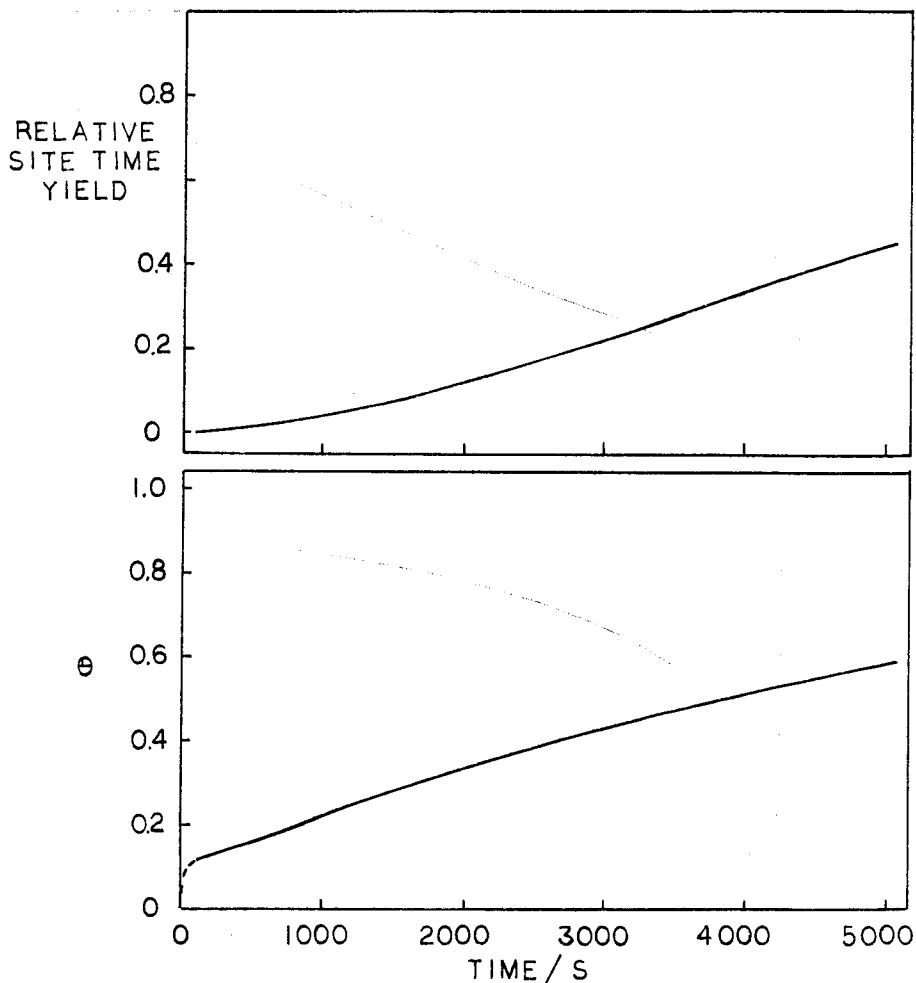

Fig. 6. Onset of the Activity and Nitrogen Uptake:  $\text{MoO}_x\text{C}_y$  Conditions same as in Fig. 2B.

### Discussion

As shown in Table 3 the steady-state rates obtained in this work are in close agreement with those obtained previously. The rates measured with the gravimetric system are somewhat smaller than those obtained with the integral flow reactor used before. This is probably due to by-passing of the catalyst basket by a fraction of the reactant gas. The steady-state rates are remarkably similar for the three catalysts despite wide differences in composition and structure in the starting materials; molybdenum has a bcc struc-

*Ammonia Synthesis on Molybdenum Nitride*

ture, molybdenum carbide a hexagonal structure, and molybdenum oxycarbide a fcc structure. This similarity in rates is especially remarkable because the ammonia synthesis is a structure sensitive reaction.<sup>24)</sup> What this indicates is that in the steady-state the three catalysts have very similar surface structures and compositions.

The gravimetric results indicate that on the molybdenum carbide (Fig. 2 A) and the oxycarbide (Fig. 2 B) the rate reaches a steady-state with a nitrogen uptake corresponding to the equivalent of one MoN monolayer. In these materials the subsurface is modified by the presence of the small interstitial elements C and O. When the sub-surface is not modified as in the case of molybdenum a quantity of nitrogen corresponding to the equivalent of one monolayer of nitrogen and two sub-layers of Mo<sub>2</sub>N are required for steady-state activity. But no more as subsequent nitrogen uptake does not affect the rate. These results demonstrate that the origin of catalytic activity in the Mo-N system resides in the topmost few layers of a modified bulk phase.

The rate of nitrogen uptake into the bulk calculated from the linear region of uptake in Fig. 3 is about 10 times slower than the steady-state rate of ammonia synthesis per surface site. This indicates that the measured rate of synthesis is not significantly being retarded by the nitridation process.

Table 2 shows close agreement between the density of active sites on molybdenum given by H<sub>2</sub> chemisorption and CO chemisorption assuming a stoichiometry of one H atom and one CO molecule per metal atom. Thus, on these Mo samples CO appears to chemisorb without dissociation provided it is accepted that H<sub>2</sub> chemisorbs dissociatively. Work by Ko and Madix (25) on Mo (100) indicates that CO adsorbs dissociatively on clean surfaces but molecularly on surfaces with overlayers of CO, or C and O. Therefore, the finding of molecular CO adsorption on this molybdenum powder could indicate that the surface is covered with an impurity which blocks the dissociative adsorption. The most likely impurity is surface oxygen which cannot be entirely removed by reduction, as suggested by the last column of Table 2.

As reported in Table 1, reduction with H<sub>2</sub> removes a considerable amount of oxygen taken up by the catalysts during their passivation. However, the meaning of this oxygen uptake is obscured by the likelihood that the porous particles of catalyst absorbed more oxygen near the pore mouths than in the interior of the particles.

A crucial question is whether the presence of an impurity could affect the conclusions concerning the number of nitrogen layers. This would depend in what manner the nitrogen was taken up by the catalysts. For

example, if the impurity were in the form of inactive islands and most of the absorption took place in patches under impurity-free portions of the surface, then the nitrogen uptake measured for steady-state activity would correspond to more layers than reported here. The situation is shown schematically in Fig. 7 A. However, the indication from the chemisorption data is that the impurity is dispersed uniformly over the catalyst surface. This is seen from its apparent ability to suppress the dissociative adsorption of CO over the entire surface. Actually, the state of the impurity on the surface is immaterial just as long as the nitrogen spreads uniformly layer by layer under the impurity with the same stoichiometry assumed before. Then, even if only part of the surface were active, the rate would reach steady-state when the same number of layers as prescribed before was formed. This is shown in Fig. 7 B. In fact, it is probable that to minimize interfacial free energy, the nitridation will occur uniformly layer by layer rather than only under patches of clean surface. Just such a spreading phenomenon has been inferred by Silverman for nitrogen take-up by an iron surface 90% of whose area was covered by promoters (26). In the initial stages of nitridation by ammonia, Silverman's measurements by Auger electron spectroscopy indicated that the nitrogen occupies a thin surface region 0.9 nm in depth, under the patches of iron covered by promoters.

Although at the steady-state the surfaces have been found to be very similar in structure and composition, initially they are quite different. This is amply demonstrated in Figs. 4-6 by their different behaviors at the beginning of the experiments. The rates of the molybdenum and the molybdenum

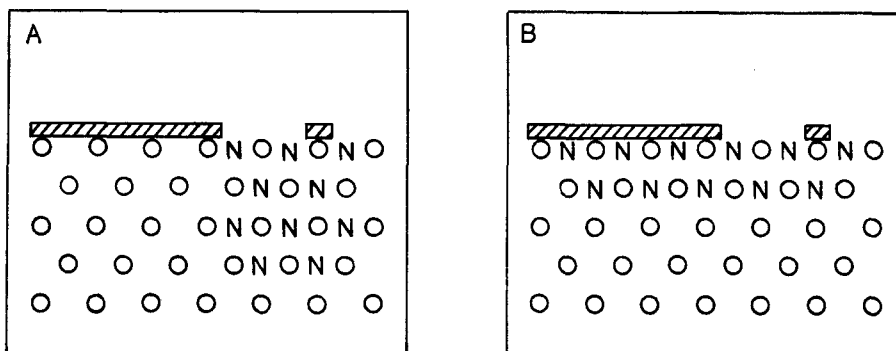

**Fig. 7.** Modes of Nitrogen Uptake with a Surface Impurity.

Circles represent metal atoms. Hatched sections represent impurities in the form of islands or dispersed.

A. Nitrogen taken up only on the contamination-free portion of the surface.

B. Nitrogen taken up uniformly so as to minimize interfacial free energy.

*Ammonia Synthesis on Molybdenum Nitride*

carbide rise relatively rapidly initially and at the same time are accompanied by equally high rates of take-up of nitrogen. For example in the first 1000 s the nitrogen uptake is 0.52 and 0.66 of a monolayer, respectively. In contrast the behavior of the molybdenum oxycarbide is markedly different, with only slow rises in the reaction rate and the nitrogen take-up. In the first 1000 s only 0.22 of a nitrogen monolayer is taken up. The variance may be due to higher levels of surface oxygen contamination in the oxycarbide. This oxygen may have to exchange with nitrogen before reaction can start, as suggested by the analytical data of the previous work.<sup>19)</sup>

### Conclusion

Evidence for the localized nature of chemisorption on metals is that the activities of three molybdenum compounds reach similar values at the steady-state. This is despite profound differences in the original materials as seen most strikingly in their adoption of three different crystalline forms. To reach steady-state the catalysts take up only a small amount of nitrogen at the surface, an amount corresponding to at most three atomic layers of nitride. Further uptake does not affect the rate. It can be therefore concluded that on these metallic substances the bulk plays no role in determining the catalytic activity, for even though the bulk is entirely different for the three materials, very close activities are reached. Our conclusion is not surprising in view of the rapid attenuation of surface wave functions into the bulk of metals.<sup>1-12)</sup> It also agrees with the many observations concerning the lack of metal particle size effect on turnover rates of structure insensitive reactions.<sup>24)</sup> Indeed, turnover rates have been found to be almost identical for the hydrogenation of ethylene on clusters of platinum consisting of a handful of atoms, and on much larger platinum particles.<sup>27)</sup> Yet, in the clusters where all metal atoms are surface atoms there does not exist a "bulk" phase at all.

### Acknowledgement

This work was initiated and carried out with support from the Center for Materials Research at Stanford University under the NSF MRL Program. We thank Leo Volpe for many helpful discussions.

### References

- 1) N. D. Lang and W. Kohn, *Phys.* **B 1**, 4555 (1970).
- 2) O. Gunnarsson, H. Hjelmberg and B. I. Lundqvist, *Phys. Rev. Lett.*, **37**, 292 (1976).
- 3) N. D. Lang and A. R. Williams, *Phys. Rev.*, **B 16**, 2408 (1977).

## S. T. OYAMA and M. BOUDART

- 4) D. Kalkstein and P. Soven, *Surf. Sci.*, **26**, 85 (1971).
- 5) R. Haydock and M. J. Kelley, *Surf. Sci.*, **38**, 139 (1973).
- 6) C. S. Wang and A. J. Freeman, *Phys. Rev.*, **B 19**, 739 (1979).
- 7) S. G. Louie, *Phys. Rev. Lett.*, **40**, 1525 (1978).
- 8) J. A. Appelbaum and D. R. Hamann, *Solid State Commun.*, **27**, 881 (1978).
- 9) F. J. Arlinghaus, J. G. Gay and J. R. Smith, *Phys. Rev. Lett.*, **42**, 5 (1979).
- 10) F. J. Arlinghaus, J. G. Gay and J. R. Smith, *Phys. Rev. Lett.*, **38**, 561 (1977).
- 11) P. J. Feibelman, J. A. Appelbaum and D. R. Hamann, *Phys. Rev.*, **B 20**, 1433 (1979).
- 12) T. Wofram, E. A. Krant and F. J. Morin, *Phys. Rev.*, **B 7**, 1677 (1973).
- 13) G. E. Moore and F. C. Unterwald, *J. Chem. Phys.*, **48**, 5378 (1968).
- 14) G. E. Moore and F. C. Unterwald, *J. Chem. Phys.*, **48**, 5393 (1968).
- 15) E. G. Moore and F. C. Unterwald, *J. Chem. Phys.*, **48**, 5409 (1968).
- 16) K. Aika and A. Ozaki, *J. Catal.*, **14**, 311 (1969).
- 17) S. Tsuchiya and A. Ozaki, *Bull. Chem. Soc. Japan*, **42**, 344 (1969).
- 18) K. Tamaru, *Trans. Faraday Soc.*, **57**, 1410 (1961).
- 19) M., Boudart, S. T. Oyama and L. Leclercq, *Proc. VIIth Int. Congress Cat.*, A 40, Tokyo, 1980, in press.
- 20) K. Matsushita and R. S. Hansen, *J. Chem. Phys.*, **54**, 2278 (1971).
- 21) P. A., Cutting, *Vac. Microbal. Techniques*, **7**, 71 (1970).
- 22) J. J. F. Scholten, Ph. D Thesis, Delft University, (1959).
- 23) S. T. Oyama, to be reported in Ph. D thesis, Stanford Univ. (1981).
- 24) M. Boudart, *Proc. VIth Int. Congress Cat.*, 1, London, (1976).
- 25) E. Ko and R. J. Madix, *Surf. Sci.*, **100**, L 505 (1980).
- 26) D. C. Siverman, Ph.D thesis, p. 191, Stanford Univ., (1975).
- 27) R. A. Dalla Betta, and M. Boudart, *Proc. Vth Int. Congress Cat.*, 1329, Palm Beach 1972.