



HOKKAIDO UNIVERSITY

Title	TRACER STUDY ON THE DISSOLVED HYDROGEN IN Fe, Cu, AND Fe-Cu PLATES
Author(s)	TAKEUCHI, Toyosaburo; MATSUYAMA, Masao; YASHIKI, Masayuki
Citation	JOURNAL OF THE RESEARCH INSTITUTE FOR CATALYSIS HOKKAIDO UNIVERSITY, 28(3), 335-346
Issue Date	1981-06
Doc URL	https://hdl.handle.net/2115/25102
Type	departmental bulletin paper
File Information	28(3)_P335-346.pdf



TRACER STUDY ON THE DISSOLVED HYDROGEN IN Fe, Cu, AND Fe-Cu PLATES

By

Toyosaburo TAKEUCHI^{*)}, Masao MATSUYAMA^{*)},
and Masayuki YASHIKI^{*)}

(Received November 10, 1980)

Abstract

Catalytic behavior of dissolved hydrogen in Fe, Cu, Fe-Cu sheets in the Fischer-Tropsch reaction was investigated by using tritium (T-hydrogen) and ¹⁴C-carbon monoxide as tracers.

The amount of preadsorbed T-hydrogen on the surface of Fe and Fe-Cu sheets markedly increased due to the addition of carbon monoxide. Methane was produced in addition to ethylene, ethane and propane on alumina-doped Fe and Fe-Cu, but did not on Fe, Fe-Cu, Cu, and alumina-doped Cu. These results were interpreted in terms of bulk diffusion of hydrogen in Fe and the occurrence of spillover of hydrogen from Fe to alumina.

Introduction

The chemisorbed hydrogen on transition metals partly migrates from the surface to the bulk. The dissolution of hydrogen in metals has been widely investigated in terms of electric resistance,¹⁾ magnetic moment,²⁾ and hydrogen embrittlement.³⁾ However, few reports on the role of dissolved hydrogen in such surface reactions as catalytic reactions have appeared in literature. In catalytic reactions of hydrogen, dissolved hydrogen in metals is occasionally significant in its participation in chemical reactions as well as in its influence on the electronic state of the catalyst.

This study concerned with the catalytic behavior of dissolved hydrogen in Fe, Cu, and Fe-Cu sheets in the Fischer-Tropsch reaction. The reaction was carried out by the use of tritium and ¹⁴C-carbon monoxide tracers. The mixing of Cu with Fe promotes oxidation and reduction of Fe during the preparation of the catalysts. The influence of alumina doped on the surface of the sheets was also investigated.

^{*)} Faculty of Science, Toyama University, Gofuku 3190, Toyama, 930 Japan.

Experimental

The following two series of the sheets were used in this study.

(a): Fe, Fe-Cu (99:1), Fe-Cu (1:1), and Cu.

(b): $\text{Al}_2\text{O}_3/\text{Fe}$, $\text{Al}_2\text{O}_3/\text{Fe-Cu}$ (99:1), $\text{Al}_2\text{O}_3/\text{Fe-Cu}$ (1:1), and $\text{Al}_2\text{O}_3/\text{Cu}$ where (a) is the series of non alumina-doped metal sheets, and (b) is the series of alumina-doped metal sheets. The purity of Fe and Cu used was 99.9%. The alloy sheets were prepared from metals by fusion technique and were rolled in a nitrogen atmosphere. The sheets doped with alumina were prepared by immersing each sheet in a solution of 10% aluminium nitrate and then drying in air. All sheets were oxidized with oxygen at 600°C for 2 hours then treated with hydrogen at 350°C for 7 hours before their use in order to activate the surface. In this oxidation process aluminium on the sheets would be changed to alumina. The amount of alumina was analyzed by using the reagents of ferron solution of cethyltrimethyl-ammonium chloride and sodium acetate. The amount of alumina on each sheet was about 0.9 mg/cm², and the deviation on each sheet was very small.

The reaction vessel was composed of several tubes as is shown in Fig. 1. The volume of each tube was 40 cc and the total volume including the pressure gauge was 160 cc. Four pieces of the sheets were placed in each tube. The size of each sheet was 5 × 10 × 0.5 mm. The reaction vessel was

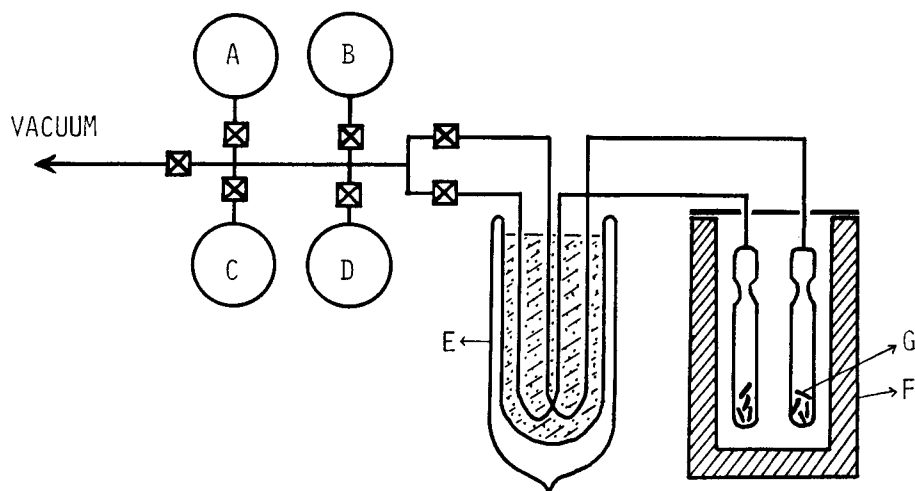

Fig. 1. Main part of the reaction vessel: (A), hydrogen; (B), carbon monoxide; (C), T-hydrogen, (D), ¹⁴C-carbon monoxide, (E), cold trap, (F), furnace, (G), metal sheet.

Tracer Study on the Dissolved Hydrogen in Fe, Cu, and Fe-Cu Plates

evacuated to 10^{-6} torr at 250°C for 3 hours after the sheets were treated with oxygen and hydrogen.

1) Adsorption of hydrogen: 15 torr of T-hydrogen, a mixture of tritium and hydrogen, was introduced into the reaction vessel while the temperature was maintained at 250°C for 8 hours. The reaction vessel was then evacuated to 10^{-3} torr, one of the tubes was separated from the reaction vessel by fusion, and the radioactivity of the sheets in the tube was measured. The sheets in another tube were used for the study on the influence of carbon monoxide on the diffusion of pre-adsorbed hydrogen from the bulk to the surface. In this case, 15 torr of carbon monoxide was introduced into the reaction vessel and left for 8 hours at 250°C . The change in the concentration of hydrogen remaining on the surface after the sheets were evacuated to 10^{-3} torr was studied. The aim of this study was to ascertain the stability of the hydrogen on the surface during the sudden change in pressure occurring with evacuation of the tube. In this case, the reaction tubes were successively separated at regular time intervals after the evacuation.

2) Adsorption of carbon monoxide: 20 torr of ^{14}C -carbon monoxide, a mixture of ^{14}C -carbon monoxide and normal carbon monoxide, was introduced into the reaction vessel. The temperature and the contact time were the same as in the case of the T-hydrogen.

In order to elucidate the reaction products on each sheet, the following reactions were carried out. 25 torr of a mixture of T-hydrogen and carbon monoxide (2:1) was allowed to react at 250°C for 140 hours. The reaction products were accumulated in a trap cooled by liquid nitrogen for analysis.

The radioactivity of T-hydrogen used was 60 mCi/mol and that of ^{14}C -carbon monoxide was 6×10^{-2} mCi/mol. The measurements of tritium and ^{14}C -carbon monoxide on the sheets were carried out by a 2π -counter. The measurement of the reaction products were carried out by radio gas-chro-

TABLE 1. The result of X-ray diffraction analysis on sheets treated with oxygen and hydrogen

Sheet	composition
Fe	Fe, $\alpha\text{-Fe}_2\text{O}_3$, Fe_3O_4
Fe-Cu (99:1)	Fe, Cu, $\alpha\text{-Fe}_2\text{O}_3$, Fe_3O_4
Fe-Cu (1:1)	Fe, Cu, $\alpha\text{-Fe}_2\text{O}_3$, Fe_3O_4
Cu	Cu

matography.

The composition of these sheets was determined by means of X-ray diffraction using $\text{CuK}\alpha$ radiation after the oxidation and the reduction. The composition of each sheet is shown in Table 1. Considerable amounts of iron oxides are found in the Fe and Fe-Cu sheets while no Fe-Cu alloy was detected as has been reported elsewhere.⁴⁾

Results

Results of the studies of adsorption are summarized in Tables 2 and 3. Each value in these tables is the average of 8 measurements. Table 2

TABLE 2. Amount of tritium on the surface of each sheet

sheet	adsorbed species	counting rate (log N)
Fe	A) ^3H	3.62
	B) ^3H , CO	4.55
	C) CO, ^3H	4.15
$\text{Al}_2\text{O}_3/\text{Fe}$	A) ^3H	4.36
	B) ^3H , CO	4.32
Fe-Cu (99:1)	A) ^3H	3.56
	B) ^3H , CO	4.51
	C) CO, ^3H	4.02
$\text{Al}_2\text{O}_3/\text{Fe-Cu}$	A) ^3H	3.85
	B) ^3H , CO	4.53
Fe-Cu (1:1)	A) ^3H	4.35
	B) ^3H , CO	4.18
	C) CO, ^3H	4.09
$\text{Al}_2\text{O}_3/\text{Fe-Cu}$	A) ^3H	5.23
	B) ^3H , CO	4.98
Cu	A) ^3H	4.80
	B) ^3H , CO	3.98
	C) CO, ^3H	3.97
$\text{Al}_2\text{O}_3/\text{Cu}$	A) ^3H	4.87
	B) ^3H , CO	4.87

(A) T-hydrogen only was adsorbed.

(B) CO was adsorbed after T-hydrogen was adsorbed.

(C) T-hydrogen was adsorbed after CO was adsorbed.

Tracer Study on the Dissolved Hydrogen in Fe, Cu, and Fe-Cu Plates

shows the amount of tritium which remained on each sheet after the adsorption and the evacuation were carried out. The respective amounts of tritium on Fe and on Fe-Cu (99:1) in case A were about 10 times greater than those in case B. In contrast the respective amounts on Fe-Cu (1:1) and on Cu were decreased following the addition of carbon monoxide. In case C, where carbon monoxide was preadsorbed at 250°C under 15 torr then evacuated to 10^{-3} torr and T-hydrogen was adsorbed, the results were very similar to those of case B. The preadsorption of carbon monoxide increased the amount of tritium on Fe and on Fe-Cu (99:1), but decreased amount on Fe-Cu (1:1) and on Cu. The doping of alumina to the sheets markedly increased the amount of tritium on Fe and Fe-Cu (1:1), but did not on Cu.

Table 3 shows the results of the adsorption of ^{14}C -carbon monoxide. The amount of ^{14}C -carbon monoxide on the sheets was not practically affected

TABLE 3. Amounts of ^{14}C -carbon monoxide on the surface of each sheet

sheet	adsorbed species	counting rate (log N)
Fe	A) ^{14}CO	2.72
	B) ^{14}CO , H_2	2.61
$\text{Al}_2\text{O}_3/\text{Fe}$	A) ^{14}CO	2.77
	B) ^{14}CO , H_2	2.80
Fe-Cu (99:1)	A) ^{14}CO	3.00
	B) ^{14}CO , H_2	2.70
$\text{Al}_2\text{O}_3/\text{Fe-Cu}$	A) ^{14}CO	2.83
	B) ^{14}CO , H_2	2.70
Fe-Cu (1:1)	A) ^{14}CO	3.57
	B) ^{14}CO , H_2	3.60
$\text{Al}_2\text{O}_3/\text{Fe-Cu}$	A) ^{14}CO	3.12
	B) ^{14}CO , H_2	3.10
Cu	A) ^{14}CO	1.94
	B) ^{14}CO , H_2	1.75
$\text{Al}_2\text{O}_3/\text{Cu}$	A) ^{14}CO	1.50
	B) ^{14}CO , H_2	1.40

(A) ^{14}C -carbon monoxide only was adsorbed.

(B) Hydrogen was adsorbed after ^{14}C -carbon monoxide was adsorbed.

T. TAKEUCHI, M. MATSUYAMA and M. YASHIKI

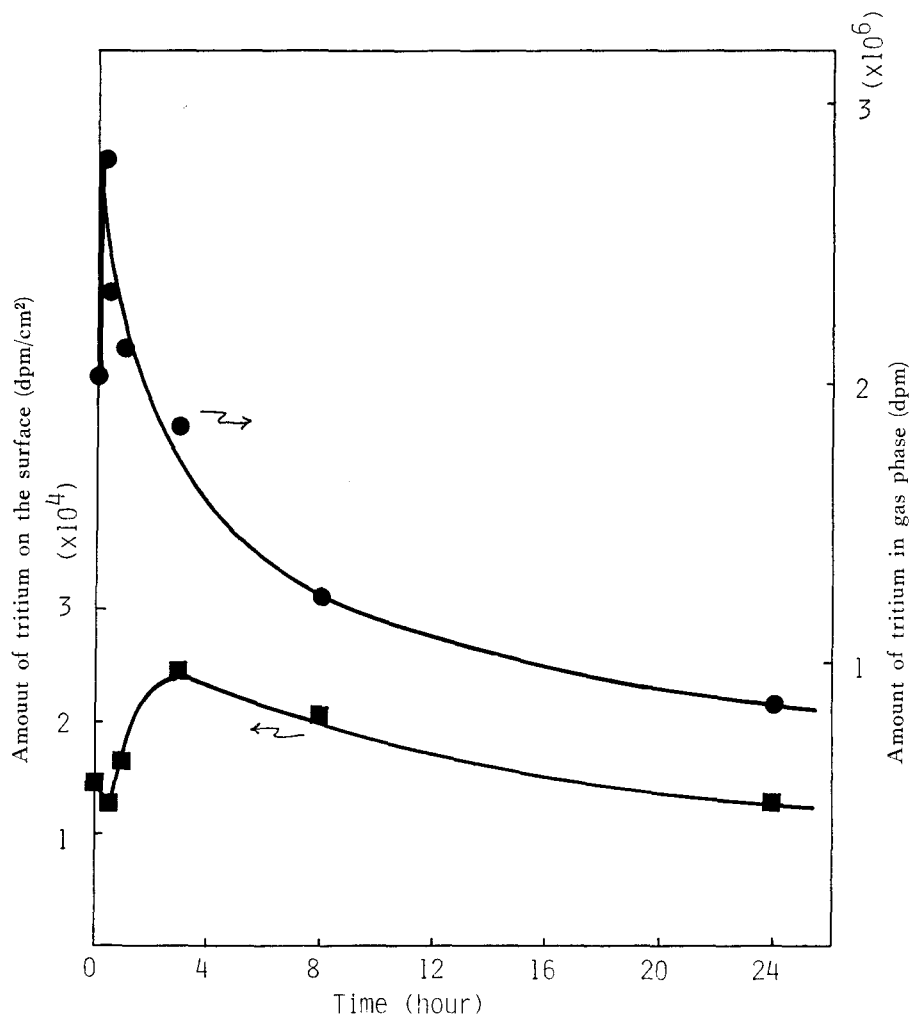

Fig. 2. The change in the amounts of tritium on the surface and gas phase (Fe).

by the preadsorbed hydrogen. The adsorption of carbon monoxide on Fe and Fe-Cu was not affected by the alumina-doping. However, the effect on Cu was very great. The amount of carbon monoxide on $\text{Al}_2\text{O}_3/\text{Cu}$ was 10 times greater than that on Cu. Figs. 2-4 show the change in the amount of tritium on Fe, Fe-Cu (1:1) and Cu by the change in the pressure during evacuation. The amount of tritium on Fe and Fe-Cu increased after 3 hours. However, the increase in the gas phase was found after 30 minutes. The tritium on Cu did not increase in the initial stage,

Tracer Study on the Dissolved Hydrogen in Fe, Cu, and Fe-Cu Plates

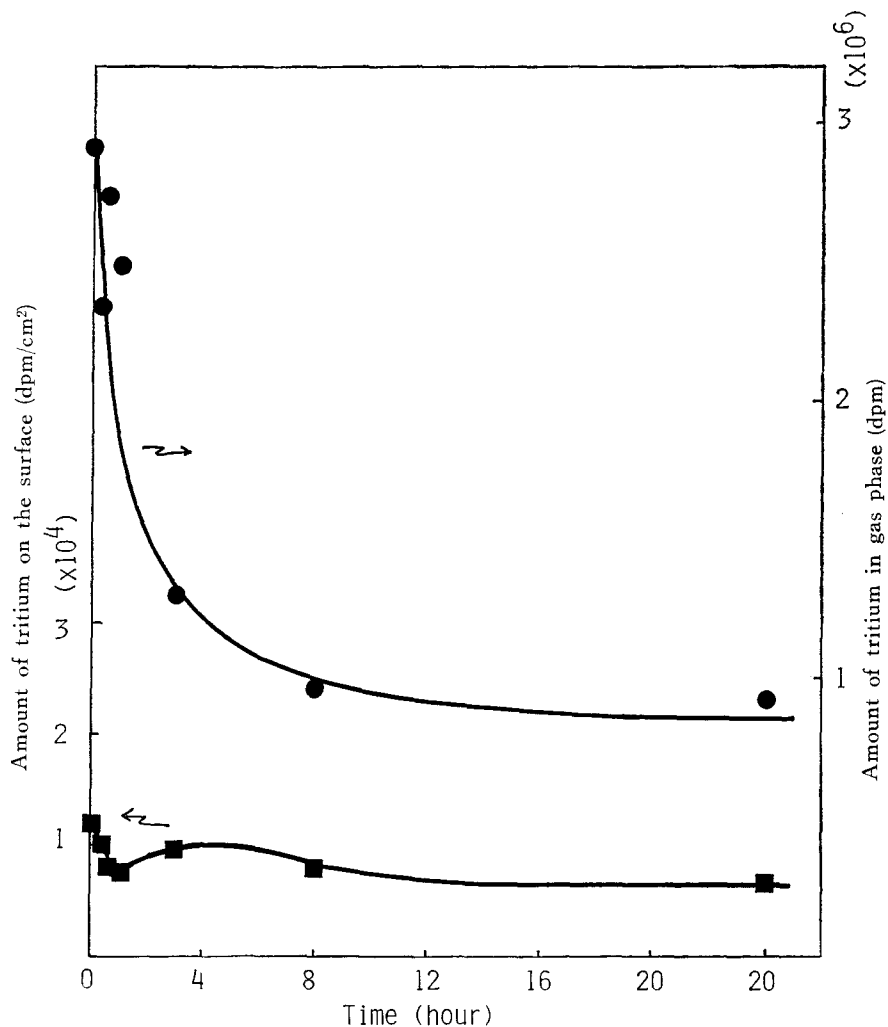

Fig. 3. The change in the amounts of tritium on the surface and gas phase (Fe-Cu 1:1).

but rather gradually decreased, and that in gas phase gradually increased.

Table 4 shows the analysis of the tritium compounds obtained from the sheets. The main products were ethylene, ethane, and propylene, while no alcohol was detected in any of the sheets. Alumina itself did not give any product. However, doping with alumina produced methane and increased the amount of propane.

Table 5 shows the amounts of total tritium derived from the sheet

T. TAKEUCHI, M. MATSUYAMA and M. YASHIKI

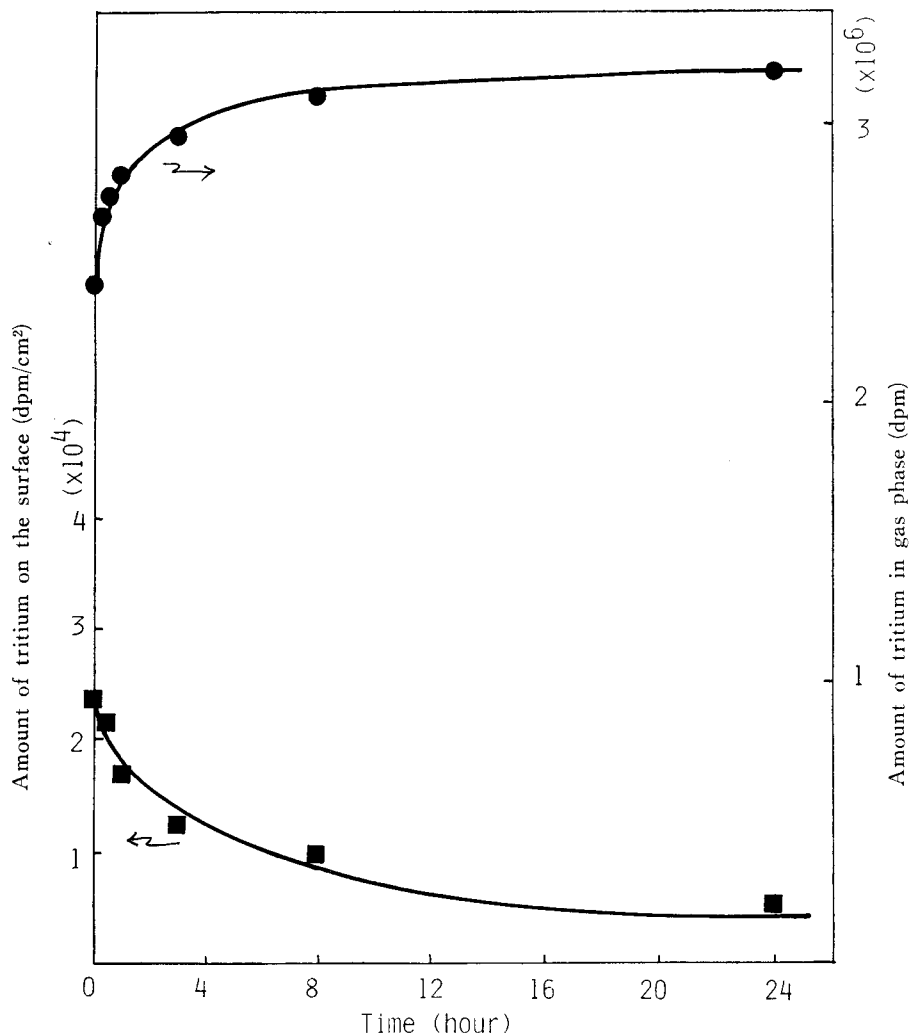

Fig. 4. The change in the amounts of tritium on the surface and gas phase (Cu).

by the exchange reaction. The exchange reaction was carried out by allowing normal hydrogen to come into contact with the Fe sheet which had been preliminarily exposed to 15 torr of T-hydrogen. The contact was continued at 250°C for 8 hours and then the chamber was evacuated to 10^{-3} torr. The pressure of normal hydrogen used for the exchange reaction was 100 torr. The temperature and the contact time were 250°C and 24 hours respectively. The table shows that the amount of tritium in the bulk

Tracer Study on the Dissolved Hydrogen in Fe, Cu, and Fe-Cu Plates

TABLE 4. Analysis of tritium compounds obtained from the sheets (250°C, 140 hrs)

sheet	Total amount of products ($\times 10^3$ dpm)	percentage of products (%)				
		CH ₄	C ₂ H ₄	C ₂ H ₆	C ₃ H ₆	C ₃ H ₈
Fe	94	—	68	10	22	—
Fe-Cu (1:1)	55	—	56	14	30	—
Cu	2	—	44	46	—	—
Al ₂ O ₃ /Fe	220	18	49	17	14	2
Al ₂ O ₃ /Fe-Cu	165	12	47	20	20	1
Al ₂ O ₃ /Cu	45	—	69	4	27	—
Al ₂ O ₃ (powder)	0	—	—	—	—	—

TABLE 5. Results of measurements of dissolved T-hydrogen

The amount of tritium on the surface of Fe (dpm)		The amount of tritium transferred from Fe to gas phase (dpm)
A	B	at 350°C, after 24 hours
4.8×10^4	7.8×10^2	5.8×10^5

A ; Before the contact with normal hydrogen at 250°C.

B ; After the contact with normal hydrogen at 350°C.

was 10 times greater than that on the surface. No increase was recognized in the amount of the exchanged tritium even though the sheet was left for several hours longer at the same temperature. This fact indicates that a large part of tritium in the bulk was drawn out and consumed by the exchange reaction.

Discussion

The number of atom layers penetrated by β -rays, L , can be estimated by the following equation ;

$$L = A/d \cdot l \quad (1)$$

where A is the penetration power of β -rays, d is the density of metal and l is lattice constant. In this study, the value of A was determined by the adsorption study of β -rays in built-up layers of tritiated palmitic acid. In the case of Fe, the value of L obtained by equation (1) was 51. Accordingly, the amount of tritium in the Fe sheet implies an average value of 51 layers. If the T-hydrogen in these layers is postulated to cover

T. TAKEUCHI, M. MATSUYAMA and M. YASHIKI

the first layer of the metal, and the isotope effect of tritium for the dissolution is neglected, the coverage of T-hydrogen on the first layer is 0.003. That is, the amount of T-hydrogen which remains on the surface layer after evacuation is very small. The amount of T-hydrogen which dissolves in equilibrium in Fe at 250°C under 15 torr was theoretically obtained by the following equation and compared with the results obtained experimentally in Table 2.

$$c = 3.7 \times p^{1/2} \times \exp(-6500/RT) \quad (2)$$

where c is the solubility of hydrogen in Fe, p is the pressure of hydrogen, and R is the gas constant. The theoretical value of c determined by equation (2) was 2.52 ppm per 4 sheets, which corresponds to 5.6×10^5 dpm of T-hydrogen. The very close correspondence between the theoretical value and the experimental value (Table 5) indicates that the dissolution of T-hydrogen attained equilibrium within 8 hours.

A large part of the hydrogen on metal diffuses quickly along the lattice imperfections and accumulates in the grain boundary of the metal, where it is preferentially consumed during chemical reactions.^{5,6)}

The increase in the amount of tritium on the surface of Fe and Fe-Cu (99:1) sheets due to the addition of carbon monoxide (Table 2) indicates that a large part of the T-hydrogen which dissolved in the bulk of the sheets returned to the surface and was trapped by the adsorbed carbon monoxide present only on the first layer of the sheets. The increase in the amount of tritium on Fe and Fe-Cu (99:1) sheets by the pre-adsorbed carbon monoxide (series c) indicates that the dissolution of hydrogen is disturbed and trapped by carbon monoxide on the surface.

The fact that no detectable amount of T-compounds could be obtained after 8 hours-contact of carbon monoxide to the preadsorbed sheet, irrespective of the increase in the amount of T-hydrogen on the sheet, suggests that the concentration of the intermediates formed in this condition is too low for any reaction to occur between them and therefore the completion of the stable products is difficult. It is not clear what intermediates are involved in the reaction in this situation. However, it is possible that such an intermediate as the aldehyde shown below may be present on the surface as has been described elsewhere,^{7,8)}

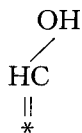

Tracer Study on the Dissolved Hydrogen in Fe, Cu, and Fe-Cu Plates

where * represents the active site.

The decrease in the amount of the adsorbed tritium on Fe-Cu (1:1) and Cu following the addition of carbon monoxide or the preadsorption of carbon monoxide may be explained in terms of the difference in the bond strength of Cu-hydrogen and Cu-carbon monoxide. A great difference was found between Fe and Fe-Cu in the change of the amount of T-hydrogen on the surface and gas phase after evacuation. (Figs. 2-4) These findings are explained in terms of the difference in the adsorption and solubility between Fe and Cu. T-hydrogen is driven off from the sites by carbon monoxide. The T-hydrogen in gas phase is transferred to the Fe sheet by adsorption and dissolution. In contrast, the T-hydrogen in Cu sheet transferred to gas phase by desorption.

In his study on ammonia synthesis, Brill⁹ concluded that the alumina in Fe catalyst did not promote synthesis. A similar conclusion was deduced by Dry *et al.*¹⁰ who studied the Boudouard Reaction on Fe. However, doping with alumina promoted the reaction of hydrogen with carbon monoxide in our study. The effect of alumina on the catalytic reaction in our study may be explained in terms of the increase in the amount of adsorbed hydrogen resulting from an increased surface area, and the occurrence of the exchange reaction of hydrogen between the OH group of alumina and adsorbed T-hydrogen.^{11,12,13} That is, T-hydrogen can be stored in alumina as well as in metal. It can be said, therefore, that the increase of T-hydrogen on the sheet selectively promotes the formation of methane. The work carried out by Dry *et al.*¹⁴ showed that the strength of CO adsorption, as reflected by the heat of adsorption, was stronger than that of hydrogen adsorption on Fe. In addition, alkali increased the heat of adsorption of CO and lowered that of hydrogen. These authors concluded that the overall effect of alkali is to enhance the Fischer-Tropsch reaction. No difference could be found between the amount of tritium on Cu and on Al₂O₃/Cu in our study. This fact depends upon the weakness of bond energy of adsorbed hydrogen on Cu, a metal of group IB, as is suggested by the heat of adsorption,¹⁵ and the activation energy¹⁶ of the H₂-D₂ equilibration reaction.

Most of hydrogen on the surface of Cu is in the state of non-dissociation. The occurrence of spillover of hydrogen from Cu to alumina would not take place readily at the temperature used in this study. The dissolution of T-hydrogen into an IB group metal is very small in comparison with those of the VIII group. In the case of Fe, a large part of the T-hydrogen exists mainly in the bulk. In contrast, in the case of Cu, T-hydrogen exists mainly

T. TAKEUCHI, M. MATSUYAMA and M. YASHIKI

on the surface. As a result, an amount of T-hydrogen on Cu was found to be larger than that on Fe.

Acknowledgements

The authors are greatly indebted to Mrs. Y. Sawada, Mr. J. Nakagawa, and Mr. N. Kijima for the measurements. They are also grateful to Prof. S. Muromachi for providing the Fe-Cu sheets.

References

- 1) F. A. Lewis, W. D. McFall and F. C. Witherspoon, *Z. Phys. Chem. N.F.*, **114**, 239 (1979).
- 2) S. Ladas, R. A. Dalla Betta, and M. Boudart, *J. Catalysis*, **53**, 356 (1978).
- 3) V. Srikrishnan, H. W. Liu and P. J. Ficalora, *Ser. Metall.*, **19**, 663 (1975).
- 4) M. Hansen and K. Auderko, *Constitution of Binary Alloys*, p. 580 (1958).
- 5) T. Takeuchi, O. Takayasu, S. Uchida and Y. Nakano, *J. Intern. Appl. Radiation Isotopes*, **26**, 736 (1975).
- 6) T. Takeuchi, D. Miyatani, K. Okamoto, Y. Takada and O. Takayasu, *Proc. 5th Intern. Cong. Catalysis, Florida, 1972*, North Holland, Amsterdam, p. 555.
- 7) H. Kölbel and K. D. Tillmetz, *J. Catalysis*, **34**, 307 (1974).
- 8) D. W. Goodman, T. E. Madey, M. Ono and J. T. Yates Jr, *J. Catalysis*, **50**, 279 (1977).
- 9) R. Brill, *J. Polym. Sci., Pt. C No. 12*, 333 (1966).
- 10) M. E. Dry, T. Shingles, C. S. van H. Botha, *J. Catalysis*, **17**, 341 (1970).
- 11) T. Sakurai, O. Takayasu and T. Takeuchi, *Japan Conf. Colloid and Surface Chem.*, preprints, p. 132 (1978).
- 12) I. D. Mikkeikin, I. A. Abronin, G. M. Zhidomirov, and V. B. Kazansky, *4th Japan-Soviet Catalysis Seminar*, preprints, No. 22 (1977).
- 13) D. Miyatani and T. Takeuchi, *J. Chem. Soc. Japan Chem. Indust. Chem.*, No. 4, 450 (1980).
- 14) M. E. Dry, T. Shingles, L. J. Boshoff and G. J. Oosthuizen, *J. Catalysis*, **15**, 190 (1969).
- 15) T. Takeuchi, M. Sakaguchi, I. Miyoshi and T. Takabatake, *Bull. Chem. Soc. Japan*, **35**, 1390 (1962).
- 16) G. Reinäcker and G. Vormum, *Z. Anorg. Chem.*, **283**, 287 (1956).