



HOKKAIDO UNIVERSITY

Title	SODIUM ATOM AS AN INTERMEDIATE IN THE RADIOLYSIS OF CONCENTRATED ALKALINE METHANOLIC SOLUTIONS
Author(s)	SAWAMURA, Sadashi; TANAKA, Masako; KATAYAMA, Meiseki
Citation	JOURNAL OF THE RESEARCH INSTITUTE FOR CATALYSIS HOKKAIDO UNIVERSITY, 28(3), 389-391
Issue Date	1981-06
Doc URL	https://hdl.handle.net/2115/25108
Type	departmental bulletin paper
File Information	28(3)_P389-391.pdf



—Note—

SODIUM ATOM AS AN INTERMEDIATE IN THE RADIOLYSIS OF CONCENTRATED ALKALINE METHANOLIC SOLUTIONS

By

Sadashi SAWAMURA^{*)}, Masako TANAKA^{*)}
and Meiseki KATAYAMA^{*)}

(Received October 6, 1980)

Dear Editor: We have studied the mechanism of the radiolysis of concentrated alkaline methanolic solution by means of pulse radiolysis and have reached to the conclusion that sodium atom intermediate is playing an important role. When we assume the intermediate, rather complicated dependence of the observed first order rate constant of solvated electrons on the methoxide ion concentration can be explained well. The radiolysis of concentrated alkaline methanolic solutions has been studied by Pikaev *et al.*¹⁾ They have proposed a mechanism which explained their experimental data well only at rather high methoxide ion concentrations, but not at the lower range.

Experiments were conducted as follows. Methanol used was dried by refluxing with metallic magnesium and distilled under nitrogen atmosphere. The methoxide solution was obtained by adding sodium metal into the methanol and its concentration was measured by titration. The pulse radiolysis studies for the solvated electron have been carried out using 4 MeV electron linear accelerator. The diagram of the system is shown in Fig. 1.

We now propose a new mechanism which successfully explains the kinetic data in the whole range of methoxide ion concentration studied. The proposed mechanism contains the scavenging of solvated electron by sodium ion to form atomic sodium and its reverse reaction, in addition to the decomposition of methanol molecule into hydrogen. The proposed mechanism is as follows:



*) Department of Atomic Science and Nuclear Engineering, Hokkaido University, Sapporo, 060 Japan.

S. SAWAMURA, M. TANAKA and M. KATAYAMA

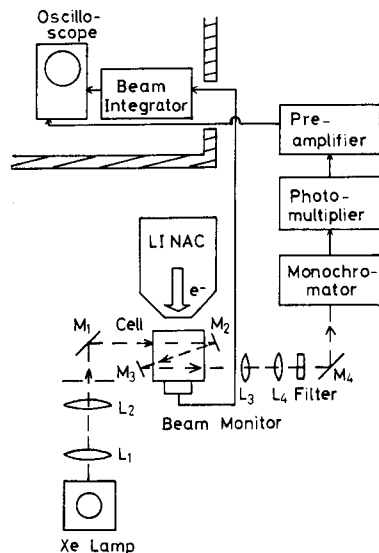
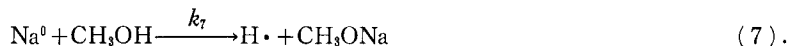

Fig. 1. Arrangement of apparatus for pulse radiolysis.



The reaction mechanism proposed by Pikaev *et al.*¹⁾ consisted of reaction (1)~(4). As mentioned above, their mechanism interpreted the kinetic data fairly well at the methoxide ion concentration range above about 2.5 M but failed at the lower concentration range. The calculated kinetic data by their mechanism should be on a single straight line (dotted line in Fig. 2).

The reaction mechanism proposed by us contains reactions (5)~(7) in addition to (1)~(4), which assumes the existence of the sodium atom intermediate. If the sodium atom intermediate is taken into consideration, the agreement between the observed first order rate constant, k' , of solvated electrons and the calculated value based on a stationary state approximation becomes satisfactory in the whole methoxide ion concentration range (Fig. 2).

To interpret the calculated values, we now introduce s -factor. The s -factor defined in Equation (1) is simply

$$k_6 [\text{Na}^0] = s k_5 [\text{Na}^+] [\text{e}_s^-] \quad (1)$$

Radiolysis of Concentrated Alkaline Methanolic Solutions

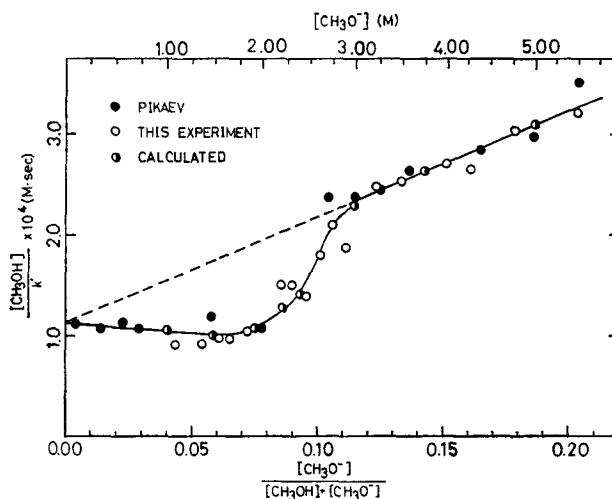

Fig. 2. The observed rate constant, k' , of the decay of the solvated electrons against the concentration of methoxide ion.

the ratio of the reaction rate of sodium atom over that of scavenging of solvated electrons by sodium ions; it reaches unity as reaction (5) and (6) approach to equilibrium.

In conclusion, the experimental data are now quantitatively interpreted by the proposed mechanism, although the existence of ion pair²⁾ such as $[\text{Na}^+ \cdots \text{e}^-]$ is not excluded completely.

We are indebted to Messrs. Y. Chiba, K. Nakamura, A. Takahashi, and S. Konya for the experimental collaboration at the early stage of the present research.

References

- 1) A. K. Pikaev, T. P. Zhestkova and G. K. Sibirskaya, *J. Phys. Chem.*, **76**, 3765 (1972).
- 2) Y. Kondo, M. Aikawa, T. Sumiyoshi, M. Katayama and J. Kroh, *J. Phys. Chem.*, **84**, 2544 (1980).