



# HOKKAIDO UNIVERSITY

|                  |   |
|------------------|---|
| Title            | X-linked Charcot-Marie-Tooth disease (CMTX) in a severely affected female patient with scattered lesions in cerebral white matter                       |
| Author(s)        | Basri, Rehana; Yabe, Ichiro; Soma, Hiroyuki et al.  |
| Citation         | Internal Medicine, 46(13), 1023-1027<br><a href="https://doi.org/10.2169/internalmedicine.46.0047">https://doi.org/10.2169/internalmedicine.46.0047</a> |
| Issue Date       | 2007  |
| Doc URL          | <a href="https://hdl.handle.net/2115/25175">https://hdl.handle.net/2115/25175</a>   |
| Type             | journal article   |
| File Information | IM46-13.pdf   |



**X-linked Charcot-Marie-Tooth disease (CMTX) in a severely affected female patient with scattered lesions in cerebral white matter**

Rehana Basri<sup>1</sup>, Ichiro Yabe<sup>1\*</sup>, Hiroyuki Soma<sup>1</sup>, Masaaki Matsushima<sup>1</sup>, Sachiko Tsuji<sup>1</sup>,  
Hidenao Sasaki<sup>1</sup>

<sup>1</sup>Department of Neurology, Hokkaido University Graduate School of Medicine,  
N15W7, Kita-Ku, Sapporo, 060-8368, Japan.

\*Corresponding author: Ichiro Yabe Tel: 81 117066028; Fax: +81 117005356.

Email address: [yabe@med.hokudai.ac.jp](mailto:yabe@med.hokudai.ac.jp)

Basri R and Yabe I contributed equally to this work.

## **Abstract**

Charcot-Marie-Tooth neuropathy (CMT) is an inherited degenerative disorder of the peripheral nervous system that results in slowly progressive distal muscle weakness, atrophy and loss of proprioception in the affected areas. X-linked CMT (CMTX) has been localized to the pericentric region of the X chromosome. CMTX neuropathy usually associated with mutations in exon 2 of the gap junction protein  $\beta 1$  (*GJB1*) gene. *GJB1* is a gap junction protein expressed in various cells including oligodendrocytes, astrocytes and myelinating schwann cells. Here we reported a female case of CMTX with a *GJB1* mutation. Patient was severely clinically affected with exhibited both the features of demyelination and axonopathy. In addition, this is the first female patient with CMTX who showed permanent atypical scattered lesions in cerebral white matter of brain in T2-weighted magnetic resonance images (MRI), which is very rare. The existence of a female patient with severe clinical symptoms may show that gain of function mechanism also lead to the disorders seen in these patients.

Keywords: gap junction protein  $\beta 1$ ; Connexin 32; Hereditary demyelinating neuropathy; Magnetic resonance imaging; X-linked Charcot-Marie-Tooth disease

## Introduction

Charcot-Marie-Tooth disease (CMT) is the most common inherited neurologic disorder, affects 1 in 2,500 people worldwide. CMT includes three subtypes with autosomal dominant (CMT1, CMT2), recessive, and X-linked forms. The frequency of CMT in Japan is reported to be 10.8 cases per 100,000 populations [1]. The X-linked form (CMTX) is found in about 10-20% of patients with hereditary demyelinating neuropathies. CMTX is characterized by slowly progressive distal muscle weakness and atrophy of the muscles resulting in characteristic steppage gait with pes cavus deformity, decreased deep tendon reflexes with sensory loss. In CMTX, males tend to be more severely affected than females due to X-linked recessive disorders. Female carriers are usually clinically asymptomatic but in some cases have developed severe symptoms with late onset. Sporadic case of X-linked CMT has also been identified [2].

The X-linked form is associated with mutations in the gap junction protein  $\beta$  1 genes (*GJB1*) on chromosome Xq13.1. *GJB1* is a gap junction protein expressed in various cells including oligodendrocytes and astrocytes and in tissues such as liver, brain and pancreas [3]. *GJB1* has two extracellular loops, one intracellular loop, two intracellular terminal domains and four transmembrane segments. *GJB1* proteins maintain the permeability of the neuron. Over 250 different mutations of the *GJB1* genes have been identified [4].

Here, we describe clinical and genetic analyses in a female patient with CMTX neuropathy who exhibited a mutation in the *GJB1* gene as well as atypical scattered lesions in cerebral white matter of brain in T2-weighted magnetic resonance images (MRI).

## Case report

A 41 year old woman presented with gait instability due to weakness of the lower limbs that appeared at the age of 21. At age 30, she noticed that slippers on the right foot came off and that the condition was worsening. At age 38, she noticed increasing weakness in the lower limbs. At age 39, she started to complain of progressive numbness in the distal arms and in the calf muscles. At age 40, she felt coldness in both lower limbs. For better management, she visited our neurological department on September 2005. Neurological examination revealed wasting of the muscles of the legs with sparing of the thigh muscles, giving the characteristic inverted champagne bottle appearance; stappage gait; diminished deep tendon reflexes in all extremities; and developed deep sensory disturbance. Any cognitive dysfunctions were not observed. Planter responses were flexor. She had no history of cerebrovascular disorder, hypertension, diabetes mellitus or any other systemic diseases. There was a similar history of illness affecting the paternal grandmother, father, paternal uncle and two of her paternal cousins; there was no history of male to male transmission (Fig. 1). Apart from this disorder, she had no family history including cerebrovascular disorder.

Laboratory studies for complete blood count, electrolytes, renal function, liver function, and vitamin B<sub>12</sub> and folate levels were normal. Cerebrospinal fluid, urine analysis and electrocardiogram showed no significant abnormalities. Electrophysiological examination (Table 1) revealed that motor nerve conduction velocity (MNCV) and compound muscle action potential (CMAP) amplitude in the median nerve were reduced with prolonged distal latencies. Sensory conduction velocity (SNCV) and sensory nerve action potential (SNAP) amplitude were also

reduced. In ulnar nerve, although distal latency and CMAP were normal, MNCV and SNCV were reduced. MNCVs were more affected in the tibial and peroneal nerves than in the median and ulnar nerves with reduced CMAP amplitudes. Temporal dispersion was observed in median and tibial nerves. SNAPs in sural nerve and F responses in median, ulnar, tibial and peroneal nerves were mostly absent. Electromyography (EMG) of the anterior tibial muscle showed signs of chronic reinnervation changes with polyphasic motor unit potentials. This finding suggested that she had the features of both demyelinating polyneuropathy and axonopathy. Electroencephalography, central conduction time in somatosensory evoked potentials (SEP) and auditory brainstem responses (ABR) were within normal limits. Brain MRI scans revealed atypical small scattered lesions were present in cerebral white matter in T2- and FLAIR- weighted images (Fig. 2). Brain and cervical MR angiographies were normal. Six months later, these abnormal signals in brain MRI did not change. The origins of these abnormal intensities were unclear.

Informed consent was obtained from the patient and a blood sample was taken for molecular genetic studies. The Hokkaido University Ethics Committee approved this study. Genomic DNA was extracted using standard procedures. The coding exon2 of *GJB1* was amplified by the polymerase chain reaction (PCR) using previously described primers [5], and the amplified PCR product was sequenced directly using the BigDye Terminator Cycle Sequencing Kit (PE Applied Biosystems, Tokyo, Japan).

Genetic analysis of our case revealed a point mutation in exon 2 of the *GJB1* gene resulting in the replacement of an arginine by a tryptophan at position 142 of the

translated protein (Arg142Trp). This mutation was previously reported in CMTX patients [3].

Based on the results of this genetic analysis, together with a positive family history without male to male transmission, and the clinical features of slowed nerve conduction velocity and peripheral weakness with atrophy of the legs, the patient was diagnosed with CMTX.

## **Discussion**

Among all CMT disorders, the frequency of CMTX is 20% in Japan. Overall 7.1% of CMTX patients show CNS involvement [6~9]. Six male patients with CMTX have been described with transient CNS symptoms and symmetrical white matter lesions that later resolved [6-8]. Recently one male patient with CMTX was described with permanent MRI signal abnormalities at the level of the corticospinal tract [9]. It is possible that *GJB1* mutations might lead to white matter abnormalities and CNS symptoms due to chronic demyelination because *GJB1* is expressed in oligodendrocytes [9]. Although MRI signal abnormalities in our case were maintained and subclinical through six months, further observation will be needed.

Many reports document clinically severely affected CMTX female patients without white matter lesion involvement [4, 8, 10, 11]. Here we have reported for the first time a female patient with atypical scattered lesions in cerebral white matter who exhibited all the clinical criteria of CMTX and had a mutation in the *GJB1* gene. Previously, CMTX patients were reported with white matter lesions in the periventricular area, the parietal white matter, and in the splenium of corpus callosum

[6-8]. Among them, only one male case showed scattered white matter lesions that are similar to those in our case [6]. CNS involvements in female patients with X-linked CMT have rarely been reported (Table 2). One female case showed upper motor neuron signs (hyper reflexes of the arms, positive Babinski sign, dysarthria, and wide-based gait) with the development of increased MRI signals in the white matter and atrophy of the distal thoracic cord [12]. Although sequence variants in the *GJB1* promoter region were detected in this case, direct DNA sequencing of the *GJB1* coding region was normal [12].

In CMTX, male patients tend to be severely affected, and females are generally asymptomatic. However some heterozygous female carriers have been severely affected [4]. In our case, MNCVs were markedly reduced, below 38 m/s, in the median, tibial and peroneal nerves, suggesting the presence of demyelination. Here we also saw that the CMAP amplitudes were markedly reduced in the median, tibial and peroneal nerves which may suggest axonopathy. Thus, this patient showed both the features of demyelination and axonopathy. *GJB1* mutations may induce both axonal and demyelinating features irrespective of the nature and position of the mutation in the *GJB1* gene [13]. To date all of the identified Japanese male patients with CMTX were severely affected and showed the features of both demyelination and axonopathy [13-16]. The degree of neuropathy of our case was as severe as those of these male patients. Previously, a case of sensorineural deafness in a female patient with CMTX was described without any clinical features of motor or sensory deficit [17]. Abnormal brainstem auditory evoked responses have recently been reported in male patients with CMTX neuropathy [18, 19]. Our case did not show such sensorineural deafness or other such associated features, nor did she display any abnormality in central visual or acoustic pathways.

A wide variation in the severity of clinical features was found in carrier females who had later onset of symptoms with some obligate carriers being asymptomatic [20]. But, our case showed early onset of symptoms at the age of 20. The mutation in the extracellular domain of GJB1 may lead to increase chances of CNS involvement [21]. The R142W substitution is present in the third transmembrane domain of the GJB1 protein which forms a part of the gap junction pore in neuron and might impair or block the channel permeability. Although exact molecular mechanism is still unknown, previously reported mutations on this transmembrane domain may cause increase the frequency of CNS involvement [7, 17]. In the CNS, gap junctions have been identified in neurons ependymal cells astrocytes and oligodendrocytes. Mutation in the transmembrane domain and extracellular domain may also lead to development of CNS lesions. At present, CMTX is thought to be caused by a loss of function mechanism. However, the existence of a female patient with severe clinical symptoms may show that gain of function mechanism also lead to the disorders seen in these patients.

In conclusion, this is the first reported case of a female patient with CMTX who was severely clinically affected, and who showed atypical scattered white matter lesions in the cerebrum. The exact molecular roles played by GJB1 in the peripheral and central nervous systems remain unclear but mutations may cause the central and peripheral nervous system abnormalities found in CMTX, the clinical severity of which is probably related to the types of mutations and their effects on GJB1 function.

**Acknowledgements:** We are very grateful to the present case for their willingness to participate in this study. This work was supported in part by a Grant-in-Aid for Scientific Research from the Ministry of Education, Science, Sports, and Culture,

Japan by a Grant from the Akiyama Foundation, and by a Grant from the Noastic Foundation.

## References

1. Kurihara S, Adachi Y, Kenji W, Awaki E, Harada H, Nakashima K. An epidemiological genetic study of Charcot-Marie-Tooth Disease in western Japan. *Neuroepidemiology* 21: 246-250, 2002
2. Latour P, Levy N, Paret M, Chapon F, Chazot G, Clavelou P, Couratier P, Dumas R, Ollagnon E, Pouget J, Setiey A, Vallat J M, Boucherat M, Fontes M, Vandenberghe A. Mutations in the X-Linked form of Charcot-Marie-Tooth disease in the French population. *Neurogenetics* 1: 117-123, 1997
3. Bergoffen J, Scherer SS, Wang S, Oronzi Scott M , Bone LJ, Poul DL, Chen K, Lensch MW, Chance PF, Fischbeck HK. Connexin mutations in X-linked Charcot-Marie-Tooth disease. *Science* 262: 2039-2041, 1993
4. Vondracek P ,Seeman P ,Hermanova M ,Fajkusova L. X-linked Charcot –Marie-Tooth disease :Phenotypic expression of a novel mutation Ile127Ser in the GJB1(connexin 32) gene. *Muscle Nerve* 31: 252-255, 2005
5. Ionasescu V, Searby C , Ionasescu R. Point mutations of the connexin32 (GJB1) gene in X-Linked dominant Charcot-Marie-Tooth neuropathy. *Hum Mol Genet* 3: 355-358, 1994
6. Panas M, Kalfakis N, Karadimas C, Vassilopoulos D. Episodes of generalized weakness in two sibs with the C164T mutation of the connexin 32 gene. *Neurology* 57: 1906-1908, 2001
7. Paulson HL, Garbern JY, Hoban TF, Krajewski KM, Lewis RA, Fischbeck KH, Grossman RI, Lenkinski R, Kamholz JA, Shy ME. Transient Central Nervous System White Matter Abnormality in X-Linked Charcot-Marie-Tooth Disease. *Ann Neurol* 52: 429-434, 2002

8. Hanemann CO, Bergmann C, Senderek J, Zerres K, Sperfeld AD. Transient ,recurrent, white matter lesions in X-Linked Charcot-Marie-Tooth Disease with novel connexin 32 mutation. *Arch Neurol* 60: 605-609, 2003
9. Kassubek J, Bretschneider V, Sperfeld AD. Corticospinal tract MRI hyperintensity in X-Linked Charcot-Marie-Tooth Disease. *J Clin Neurosci* 12: 588-589, 2005
10. Tabaraud F, Lagrange E, Sindou P, Vandenberghe A, Vallat JM. Demyelinating X-Linked Charcot-Marie-Tooth Disease: Unusual electrophysiological findings. *Muscle Nerve* 22: 1442-1447, 1999
11. Young P, Grote K, Kuhlenbaumer G, Debus O, Kurlemann H, Halfter H, Funke H, Ringelstein EB, Stogbauer F. Mutation analysis in Charcot-Marie-Tooth Disease type 1: point mutations in the MPZ gene and the GJB1 gene cause comparable phenotypic heterogeneity. *J Neurol* 248: 410-415, 2001
12. Hisama FM, Lee HH, Vashlishan A, Tekumalla P, Russell DS, Auld E, Goldstein JM. Clinical and molecular studies in a family with probable X-linked dominant Charcot-Marie-Tooth disease involving the central nervous system. *Arch Neurol* 58: 1891-1896, 2001
13. Hattori N, Yamamoto M, Yoshihara T, Koike H, Nakagawa M, Yoshikawa H, Ohnishi A, Hayasaka K, Onodera O, Baba M, Yasuda H, Saito T, Nakashima K, Kira JI, Kaji R, Oka N, Sobue G. Demyelinating and axonal features of Charcot-Marie-Tooth Disease with mutations of myelin related proteins (PMP22,MPZ and Cx32): a clinicopathological study of 205 Japanese patients. *Brain* 126:134-151, 2003
14. Ikegami T, Lin C, Kata M, Itoh A, Nonaka I, Kurimura M, Hirayabashi H, Shinohara Y, Mochizuki A, Hayasaka K. Four novel mutations of the connexin

- 32 gene in four Japanese families with Charcot-Marie-Tooth Disease type1. *Am J Med Genet* 80: 352-355, 1998
15. Yoshihara T, Yamamoto M, Doyu M, Misu KI, Hattori N, Hasegawa Y, Mokuno K, Mitsuma T, Sobue G. Mutations in the peripheral myelin protein zero and connexin 32 genes detected by non-isotopic RNase cleavage assay and their phenotypes in Japanese patients with Charcot-Marie-Tooth disease. *Hum Mutat* 16: 177-178, 2000
  16. Numakura C, Lin C, Ikegami T, Guldborg P, Hayasaka K. Molecular analysis in Japanese patients with Charcot-Marie-Tooth disease: DGGE analysis for PMP22, MPZ, and Cx32/GJB1 mutations. *Hum Mutat* 20: 392-398, 2002
  17. Stojkovic T, Latour P, Vandenberghe A, Hurtevent JF, Vermersch P. Sensorineural deafness in X-Linked Charcot-Marie-Tooth Disease with connexin32 mutation (R142Q). *Neurology* 52: 1010-1014, 1999
  18. Bahr M, Andres F, Timmerman V, Nelis ME, Van Broeckhoven C, Dichgans J. Central visual, acoustic, and motor pathway involvement in a Charcot-Marie-Tooth family with an Asn205Ser mutation in the connexin 32 gene. *J Neurol Neurosurg Psychiatry* 66: 202-206, 1999
  19. Kawakami H, Inoue K, Sakakihara I, Nakamura S. Novel mutation in X-linked Charcot-Marie-Tooth disease associated with CNS impairment. *Neurology* 59: 923-926, 2002
  20. Cochrane S, Bergoffen J, Fairweather ND, Muller E, Mostacciuolo ML, Monaco AP, Fischbeck KH, Haites NE. X-Linked Charcot-Marie-Tooth Disease (CMTX1): a study of 15 families with 12 highly informative polymorphisms. *J Med Genet* 31: 193-196, 1994

21. Panas M, Karadimas C, Avramopoulos D, Vassilopoulos D. Central nervous system involvement in four patients with Charcot-Marie-Tooth Disease with connexin 32 extracellular mutations. *J Neurol Neurosurg Psychiatry* 65: 947-948, 1998

## Legends

Table 1 Electrophysiological study

Table 2 X-linked CMT in female patients with CNS involvement.

Figure 1 Family pedigree of the Japanese family with X-linked Charcot-Marie-Tooth neuropathy (CMTX) modified for patient confidentiality. Symbols: males=squares; females=circles; affected=filled symbol; unaffected=empty symbols. Arrow indicates affected case.

Figure 2 Atypical small scattered white matter lesions (arrows) on T2- weighted magnetic resonance images (1.5T) from our female patient with X-linked Charcot-Marie-Tooth disease. Note involvement of small lesions in cortical area (a) and periventricular area (b) of the cerebrum.

Table 1  
Electrophysiological study

| Peripheral nerves(Right) | Distal latencies(ms) | Motor NCV (m/s) | Sensory NCV (m/s) | CMAP amplitudes(mv) | SNAP amplitudes( $\mu$ v) |
|--------------------------|----------------------|-----------------|-------------------|---------------------|---------------------------|
| Median                   | 4.8 (<3.8)           | 37 (>55)        | 38 (>50)          | 3.6                 | 3.3                       |
| Ulnar                    | 2.6 (<3.5)           | 42 (>55)        | 43 (>50)          | 6.7                 | 5.2                       |
| Tibial                   | 4.8 (<5.0)           | 26 (>45)        | /                 | 0.3                 | /                         |
| Peroneal                 | Absent               | Absent          | /                 | Absent              | /                         |
| Sural                    | Absent               |                 | Absent            |                     | Absent                    |

NCV: Nerve conduction velocity, CMAP: Compound muscle action potential, SNAP: sensory nerve action potential. /; not examined

Table 2. X-linked CMT in female patients with CNS involvement.

| case | sex | Age at onset | Age at examination | Clinical symptoms   | MRI findings  | CX 32 mutations                                   | Study year                  |
|------|-----|--------------|--------------------|---|---|---|-----------------------------|
| 1    | F   | 20           | 56                 | Peripheral sensory motor neuropathy, spasticity, hyperreflexia.                                   | Bilateral increased signal in the white matter, atrophy of conus medularis. | Sequence variants in the connexin promoter region | Hisama FM et al.. 2001 (12) |
| 2    | F   | 8            | 8                  | Sensorineural deafness and impaired vibratory sensation. No deficit in motor and sensory pathway. | Not mentioned   | R142Q   | Stojkovic.T, 1999 (17)      |
| 3    | F   | 20           | 41                 | Weakness and numbness of all extremities, diminished reflexes and sensation of the lower limbs.   | Scattered small lesions in the cerebral white matter.                       | R142W   | <b>Present case</b>         |

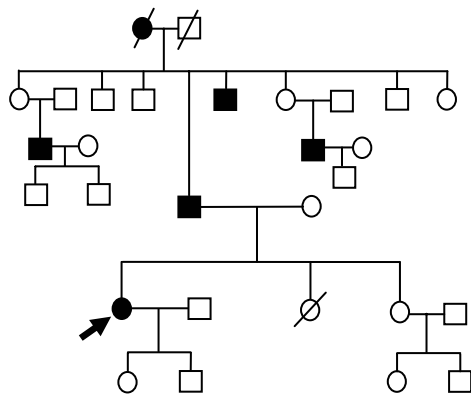
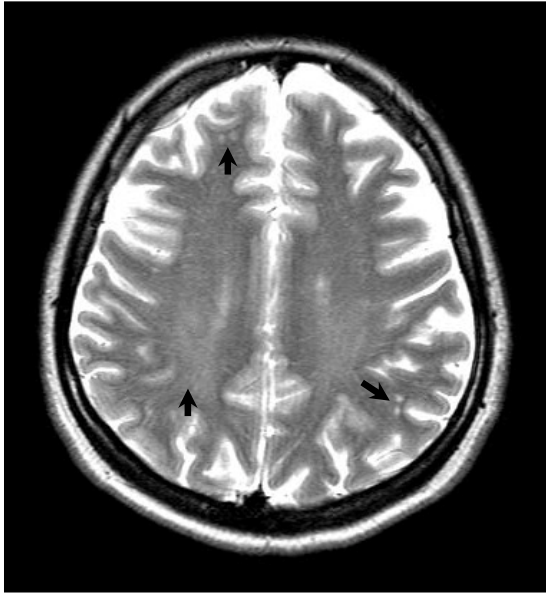

Fig. 1. Family tree of the Japanese family with X-linked Charcot-Marie-Tooth neuropathy (CMTX) modified for patient confidentiality. Symbols: males=squares; females=circles; affected=filled symbol; unaffected=empty symbols. Arrow indicates presented case.



**a**



**b**

Fig. 2. Atypical small scattered white matter lesions (Bar indicates) on T2- weighted magnetic resonance images in X-linked Charcot-Marie-Tooth neuropathy. Note involvement of small lesions in cortical area (a) and periventricular area (b).