



HOKKAIDO UNIVERSITY

Title	AN ECO-PSYCHOLOGICAL STUDY OF PARENT-CHILD RELATIONSHIP AND CHILD DEVELOPMENT
Author(s)	MIYAKE, Kazuo; 三宅, 和夫; WAKAI, Kunio et al.
Description	
Citation	乳幼児発達臨床センター年報, 1, 9-27
Issue Date	1978-05
Doc URL	https://hdl.handle.net/2115/25178
Type	departmental bulletin paper
File Information	1_P9-27.pdf



AN ECO-PSYCHOLOGICAL STUDY OF PARENT-CHILD RELATIONSHIP AND CHILD DEVELOPMENT*

Kazuo Miyake, Kunio Wakai, Nobumoto Tajima, Michiko Seki,

Hokkaido University

Mamoru Gotoh, and Hiroshi Usui

Hokkaido University of Education

SUMMARY

The period around school entrance is a critical stage of special importance in child development. In an attempt to grasp realistically and adequately the true picture of children's basic problems in behavior and adjustment at this stage, we launched this study with a grant from the Ministry of Education. Our subjects were 25 children and their parents. These children were enrolled in the older group of our experimental kindergarten. This permitted us to collect various base data such as children's growth history, their general ability and achievement, and their family background. In this study we collected many kinds of new data through observations on the triadic interaction among parents and child in home settings and in the laboratory, questionnaire surveys and interviews with parents, and teachers' ratings on child behavior in kindergarten and primary school.

Analysis of the data and discussions up to this point resulted in findings as follows :

1. Patterns of parent-child interaction in the home setting were classified into several types. F type in which the father holds the interaction initiative was found to be much more field-independent and richer in terms of topics in their verbal commerce than M type in which the mother plays a key role.
2. We devised a new set of analytical frameworks for complex interaction which may become a contribution to the development of research of this sort.
3. It is re-affirmed that the child's behavior and mother-child relation were much better understood and explained when related especially to the father.
4. Parental judgments and attitudes on preschool education, reward and punishment, and the contributing factors to school success were shown to be greatly universal.

* This study was supported by a research grant from the Ministry of Education for the years 1976 and 1977. Reprints may be obtained from K. Miyake, the Faculty of Education, Hokkaido University, Sapporo 060, Japan.

CONTENTS

I . Problems and Purpose of This Study	(3)
II . Method	(5)
1. Subjects	(5)
2. Settings	
(1) Home setting	(5)
(2) Controlled laboratory setting	(6)
A. Father-child situation	(6)
B. Mother-child situation	(6)
C. Father-mother-child triadic situation	(6)
(3) Questionnaire and interview with parents	(7)
3. Child's performance measures	(8)
4. Child behavior rating based on observation	
in kindergarten	(8)
5. Observation and behavior rating	
by primary school teacher	(8)
III . Progression of Data Collection and Analysis,	
and Some Results	(8)
1. Analytical procedure of parent-child interaction	
in the laboratory setting	(8)
(1) Provision of base materials for analysis	(8)
(2) Analytical units and coding systems	(9)
(3) Distiction of the levels of interaction	(10)
(4) Interactional patterns in triadic situation	(10)
2. Fundamental viewpoints in the analysis of interactional	
processes	(11)
(1) Viewpoints in the analysis of dyadic relation	(11)
(2) Standpoints in the analysis of triadic relation	(12)
3. Results from home setting observation	(12)
(1) Proportion of each family member's verbalization	
at supper	(12)
(2) Comparison between M and F Type in terms of	
the contents of parental verbalization	(13)
(3) Analysis of initial utterances and sub-IUs	(14)
(4) Comparison of the interactional structure	(15)
4. Some results of the questionnaire	
and interview with parents	(15)
IV . Problems for Future Study	(17)
References	(18)

I . Problems and Purpose of This Study.

The period of preschool years is in fact a critical time for the development of children. In some prevailing developmental theories this period is explicated as the most significant stages in the whole series of human psychological reorganization. In this stage a child masters the fundamental skills of life, develops rapidly his linguistic and cognitive abilities, and displays further development of self-consciousness and sociability, and these in turn lead him to independence from his parents and to the establishment of new interpersonal relationships with other people. At four years of age most children come to have the first opportunity of mass training and education in a kindergarten or nursery school, and except for a few special cases, they enter a primary school at six.

These changes in their life and their new experience of participation in mass activities affect to an unestimable extent their later development. And the developmental changes in children now inevitably act back again on the environmental conditions, especially on the social and personal surroundings. If parents only realized these facts, they would come to change their attitudes toward the youngsters and to hold new expectations for them. Relationships with peers also change with children's age and so do the forms of their play.

Although everyone thus agrees that the preschool period is of extreme importance for children's behavior and personality development, little is known about the underlying laws of their psychological functioning and development during this period. To answer this problem we will need to strive for the steady accumulation of much more research data and for the theoretical crystalization from an audacious and unbiased point of view.

At present, we should like to make a multiphasic approach to the reality of children's life and adjustment from a standpoint as wide as possible and thus try to get into the comprehensive understanding of each child. Through that endeavor we hope to find some truly significant variables for studying children and to develop new analytical procedures for realistic and profound insight into the nature of children. By integrating the data obtained thus on the higher level, we will be able to explore educational conditions for promoting desirable child development in ways of ecological validity (in some respects our position may lead to the notion of "the problem of the match" by Hunt. Hunt, J. McV., *Intelligence and Experience*, Ronald Press, 1961.)

This research project was launched on the basis of the reflection on our longitudinal studies entitled "The Mother-Child Relationship and Personality Development in Infants and Children" which have been done over the last decade, and based on our critical discussions on other research of this sort both in this country and overseas. Although current progress in human development research might be impressive in volume, there still remain many problems we should like answered in the near future. The following are among the major issues on which our concern will be focused throughout this research.

1. *Correspondence or consistency of the parent-child interrelation in different situations which vary in the degree of experimental set-up or control.*

Studies on the interactional behaviors between parents and child were often carried out with questionnaire or interview technique in the early stages of the history in the field of human development research. In recent developments in this field, a great number of the observational and experimental studies on the parent-child interaction have been reported. Each of these studies, however, varies in the degree of situational control. In a

laboratory setting we may present a task to a child and observe how his mother helps him and how the child responds. But it cannot be assured that we can regard the interactional pattern between mother and child in that setting as their typical pattern in every setting. We may not insist that behaviors displayed in the experimental situation are *not* typical, but at the same time there is no assurance that they *are* typical. In order to get this assurance we need to obtain data of the natural pattern of the parent-child relation in daily life, and to examine the similarity or stability of the interactional patterns in different settings.

2. *Valid measurement of the truly reciprocal interaction processes between parents and child in an attempt to grasp their "relationship" from the aspect of child influence on the parents as well as parental effects on the child.*

Most studies on parent-child relations in the past have tended to regard the relationship as an uni-directional process from parent to child. Namely, behaviors and disposition of parents were often posited as the antecedents or stimuli, and the child's behaviors and traits as the consequents or responses. This type of approach never led to a valid understanding of the truly reciprocal relationship between parent and child. It would also be a hindrance to understand the parent-child interaction from the relative and contextual standpoint on which we have put special emphasis in our previous work. In recent years there appeared several studies with infrahuman subjects which were guided by the notion of interactional reciprocity between the mother and the newborn. It should be hoped that much data of this sort on human subjects will be accumulated extensively.

3. *One-sidedness of the dyadic analysis of the triadic parent-child interaction.*

As stated above, there were not a limited number of studies which surely connected parental variables to child behavior. In most of those studies the "parent" was the mother. The natural bond of child with his biological mother is indeed much closer than that with his father, especially in the prenatal stage. It can safely be said that the relative directness of maternal influence on the child remains the same in the early years of his life. From the very biological linkage with the child, however, the existence and role of father should never be neglected or regarded as of less importance in favor of the mother's role. It is an irrefutable fact that the father may take more critical roles for the child's development in some stages, though just the opposite may be true in other stages. Furthermore, the problems of the relative importance of mother's and father's role is only part of the total aspect of parent-child relationship. Therefore, the issues in parent-child relations ought to be understood in the triadic framework of father-mother-child as being the essential structure. In addition, it is not satisfactory to analyze this triadic relationship as a parallel process by the three actors. Instead it should be determined as a complex structure with multi-strata in which mother, father, and child work directly and indirectly on each other in a fine interactional network.

Hoping to resolve those issues mentioned above, we will make multi-phasic measurements on the kinds of behavior tendencies displayed by the children and how they interact with their parents, siblings, peers, and teachers, in the respective settings of family environment, neighborhood, kindergarten, school, and in the laboratory.

Our subjects were 25 children and their parents. We will pay special attention to the examination of the correspondence of each member's behavior in a triad and the interaction patterns among the members, based on the observational evidences in several settings under different conditions of experimental control.

To state the problem succinctly, our purpose in this study is to find out meaningful variables for deeper understanding of children and consequently to contribute to the search for educational enterprise furthering adequate development in children.

II. Method.

1. Subjects.

This study has been carried out over substantially two years from 1976 to 1978, and 11 older children enrolled in the class of our experimental nursery school and their parents have served as the subjects for our research in 1976. In 1977, the second year of the project, our subjects were 14 children and their parents. This latter group of children had been in the younger section of the class in the previous year and shifted to the older group in 1977. The location of each subject's home is very close to our laboratory. All the children have had the experience of free play and group activities for three hours a day, 5 days a week (Monday through Friday), for two years in the experimental nursery school. Thus the parents understood well our purpose and there had been established a good cooperative relationship and rapport with parents as well as children.

2. Settings for data collection.

The basic data for our study were collected in three main settings, in the home environment, in the controlled laboratory situation, and during the interview with parents. Outline of each of the settings is seen below.

(1) Home setting.

Two observers (1 male and 1 female) who were familiar to the child and parents, and to some extent knew about the members of the family through occasional home visits and the events such as kindergarten bus excursions, field days, etc., visited each home. They observed and described the interaction between child and parents for two hours, with special observation during supper time. Verbal interaction between them during the meal were tape-recorded for 20 minutes from the beginning. The recorded verbal commerce were transcribed immediately after the visit, and a detailed description of their behaviors in the setting, including non-verbal interaction, and of the setting itself, was made in a form that would permit the analyzer who might have no previous knowledge about the family to get a realistic picture of the streams of behavior and the situation. After the observers left the home they rated the patterns and tendency of each family member's behavior in that situation, with the rating schedule shown in Appendix A.

In the home setting it was our aim to obtain data on the unconstrained interaction between the child and parents so it was stressed that the observers should avoid interacting with anyone of the family and just watch their behavior from an unnoticed spot. Nevertheless, on completion of the data collection the observers had a time of informal conversation with the parents in that they talked about the child's behavior in the kindergarten which had no direct relevance to the research, and asked about the family life. The observers also asked whether or not parents felt uneasy and tense by the observers' visit. Responses from parents in the course of the talk, however, were used as additional clues for subsequent ratings on their behavior in the home setting.

(2) Controlled laboratory setting.

Each triad consisting of father, mother, and child was asked to come to the laboratory, and the pair of father and child, or mother and child, or the triad of the three was given a certain set of tasks. The interaction between the two or three persons on the tasks was recorded on video-tape. In this laboratory task setting three sessions were provided so that each pair (child and father or child and mother) and the triad of the three experienced all three task sessions with the materials: high control, low control, and free play. This procedure was for the purpose of allowing us to examine the change and consistency of interactional patterns of the same pair of the two or three persons, depending upon the differential degree of control in the same laboratory setting.

In each of the three dyadic interaction sessions, the subjects repeated their trials three times, and just before the father or the mother began each trial he or she was given information on the performance level by an average child of same age as their own child, and was asked to estimate the level of their own child's performance in the light of the information given. Parental motivation and involvement in the child's activity and performance were apparently heightened by this instruction.

A. Father-child situation.

i) Regular task session: Problem was a block-stacking. This consisted of 24 colored blocks with different forms. The child's task was to pile up the blocks one at a time using only one hand, and his trial terminated when even one of the towered blocks fell down, whether or not he wanted to try the remaining blocks. In the first and second trial the father was allowed to help the child by verbal encouragement and suggestion in advance of the solution but with no direct physical teaching. The father was also instructed that he had to restrain his verbal help after once his child began the task. The standard duration of time needed for the first and second trial was 5 minutes all together, but there was no strict time limit. In the third trial, however, it was rather strongly told that father should have his child pile up as many blocks as possible in 5 minutes.

ii) Free play session with the material: The subjects were permitted to play freely with the same blocks for 10 minutes. The key for the observation in this session is how the father engages in the task and the child's performance.

B. Mother-child situation.

i) Regular task session: The material here was a set of lego-blocks. The child's task was to construct three things, for example a small house, consulting the models on an accompanying instruction sheet. In this session the subject's trials were repeated three times and the instructions to the mother were basically the same as in the father-child situation.

ii) Free play session: The child and mother were left to play freely for 10 minutes with the same lego-blocks as in the regular task session. The mother was told that she could be entirely free with regard to play and the child's behavior.

C. Father-mother-child triadic situation.

i) Regular task session: The task in this session was a classification in which some objects in the subordinate categories were to be placed in inner circles of a concentric classification disc. The father or mother or both were expected to show their child how to attack the problem, for example "rabbits belong to the animal kingdom, animals are members of living things, etc." When parents judged that the child understood the classification rule (in

a maximum time of 5 minutes), they reported it to the experimenter who had been waiting in a corner of the room for the conclusion of the parents's consultation with child. Then the experimenter tested the child on the task, having him try to place each object on the proper zone of the disc and to explain the reason for his placement.

ii) Free play session: After the test session, father, mother, and child played freely for 10 minutes with the lego-blocks which were used in the mother-child situation.

(3) Questionnaire and interview with parents.

Parental attitude toward their child and their recognition on their own parent-child relationship should be taken into account as the important factors which determine the behavior and response by each. We then provided a new form of questionnaire in order to get data of parental perception on their own parent-child relationship. In the interview responses from parents to the items in the questionnaire were confirmed and complemented, if necessary, with additional inquiry. Thus, our procedure was that which combined questionnaire with interview, and so might more properly be called the "Questionnaire-interview technique."

Though detailed description of each item is omitted here, the questionnaire consisted of 76 items in total number which were classified into 10 categories as shown below.

Contents of the Questionnaire (A)

a . General information on parental daily life	11 items.
b . Parental recognition on child's daily life	11 items.
c . Parents' perception on child's personality and behavior	9 items.
d . Living conditions for child in the family	4 items.
e . Child treatment by parents in daily life	10 items.
f . Recognition on the spouse's relationship with child	10 items.
g . Practice and opinions on child rearing and discipline	11 items.
h . Response to child behavior in some imaginative critical situations	5 items.
i . Parental expectation for child development	4 items.
j . Basic ideas on the nature of children	3 items.

As a second instrument for assessing parental attitude we used another questionnaire. Two of our research staff, Miyake and Tajima, were also members of the Japan-U.S. joint project entitled "The Cross-Cultural Study on the Influence of Socializing Agents upon Cognitive Functioning, Communication Style, and Educability of Preschool Children in Japan and the U.S.," which was led by R.D. Hess of Stanford University and H. Azuma of Tokyo University. Since some data pertinent to our purpose are kept from the sample of the above project, we borrowed several questionnaire items and gave them to our parents as a parallel test "Questionnaire (B)" for comparison. The interview with parents was conducted at our laboratory when they were invited to the task sessions with their child. The time needed for the interview with a parent ranged from 40 to 60 minutes. A female specialist (Mrs. Hayashi) served as the interviewer with mothers and the second author of this paper, Wakai, was the interviewer with fathers. The interviewers checked parental responses to the questionnaire and recorded additional information in the form. They also rated parents' behavior and

attitude in the interview on a supplementary rating scale consisting of 13 items.

3. Child's performance measures.

Since the subjects for this research were, as stated earlier, the children enrolled in the older group of our experimental kindergarten, various background information had already been obtained concerning their growth history, family conditions, father's occupation, etc. Those basic data are, however, too indirect for obtaining a good picture of the child's behavior and disposition displayed in real settings. Hence, it was necessary for us to use measures which might tap directly the child's performance and attainments.

The following items were among these measures employed ;

a) IQ Score, b) Boenton Visual Memory Test, c) Image Ability Test, d) Communication Competence, e) Persistence, f) Conservation, g) Matching Familiar Figures, h) Delay of Gratification, i) Resistance to Temptation, j) Self Reinforcement, k) Locus of Control.

4. Child behavior rating based on observation in kindergarten.

The kindergarten teacher and another female staff member who knew the children well rated each child on a scale consisting of 19 items, based on their observation of children's activities and adjustment for a year before they entered primary school.

5. Observation and behavior rating by primary school teacher.

At 4 months after the children began primary school life, we asked their teachers to respond to a questionnaire on child adjustment to school, and to rate each child's behavior tendency on a 12-item scale.

III. Progression of Data Collection and Analysis, and Some Results.

The initial plan of data collection on the 11 cases for the first year 1976-77 of our 2-year project has been completed, and additional follow-up data after the children entered primary school, which had been omitted the original schedule, were also obtained for the second time primarily with their cognitive performance. As to the 14 cases for the second year 1977-78, all the data which scheduled in the initial plan were also collected successfully.

Although the total picture of our results will not be available until the data collection and analyses is completed for the second year, we are now intensively analyzing the data obtained so far. There is a great variety in our data and the methods of analysis may and must be devised in new forms. Here are reported the fundamental problems of our treatment of data (basic ideas and methods of analysis) and some of the results already obtained.

1. Analytical procedure of parent-child interaction in the laboratory setting.

(1) Provision of base materials for analysis.

Raw materials obtained in the controlled laboratory setting were the VTR records of the interaction between child and father or mother or among the three. At first, those records were made into written transcriptions through repeated reproduction of the VTR. In the process of making transcriptions special efforts were devoted to describe as clearly and effectively as possible the situation and parent-child interaction (including the nonverbal as

well as verbal) in that only by reading the transcriptions the analyzer can understand how and whose preceding particular verbal behavior or motor action elicited the subsequent verbalization or motor response on other people, and the latter in turn served as a stimulus or cue to the following reaction.

(2) Analytical units and coding systems.

Verbal records in transcriptions were dissected into units on two levels. The first is the communication unit (CU) which is differentiated in terms of the meaning (content) of the subject's utterances.

Another is the interaction unit (IU) which is determined by sequential continuity between the verbal stimulation by the one member in the interaction and response from the other. According to the above definition one utterance (or a sentence) is not necessarily one CU and two discrete utterances which have the same semantic content could be counted in one CU. As for the IU, if one CU from anybody (the actor) in the interpersonal relation succeeded in eliciting another person's (the patient's) response it was judged that there occurred an interaction, and the incidences of the interaction were depicted by solid lines with arrows in the *tree diagrams* of the first-hand analysis. When the patient showed no overt reaction but mere acceptance to the actor's appeal, the interaction was judged to have terminated at that point and was scored as one IU.

Depending on its content each CU is coded according to a given system as shown below.

1. Utterances in expectation for some responses from the other person.
 - Question Q.
 - Direction or order D.
 - Proposal P.
2. Responses to the action from the other person.
 - Reply R. Approval and Acceptance A.
 - Explanation E. Negation and Refusal N.
3. Utterances which do not necessarily expect responses from the partner, or which needed no action from the partner.
 - Statement S. Praise PA
 - Teaching Behavior TB. Negative Acceptance NA

(The denotations listed here are not perfect indications of the actual codings. A better system must be devised.)

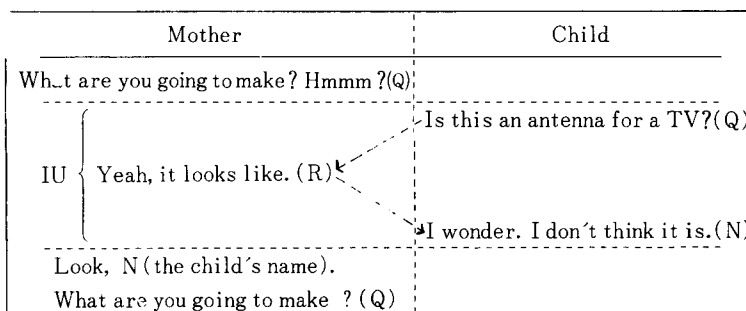

Fig.1. An Example of Interaction Analysis.

Parts of the non-verbal behavior have been subjected to the same coding treatment seen above, but a new set of "non-verbal behavior categories" will be worked out soon.

In Fig. 1 are shown several examples of the dissection of CU and IU, and of the coded utterances in a mother-child dyadic situation.

(3) Distinction of the levels of interaction.

In order to examine the persistency and expansiveness of interaction in the dyadic or the triadic situation we distinguished four levels of interaction as follows ;

Level A : no sign of interacting relation.

Level B : a dyadic interaction is just about to appear.

Level C : an established dyadic interaction is clearly seen.

Level D : a triadic interaction is clearly seen.

In the analysis of dyadic interactions there could be three levels—A, B, and C—but because the interactions were to be dichotomized in terms of who was the trigger of the interaction in the dyad, we eventually arrived at 6 fundamental types. In the analysis of triadic interactions there are 4 levels—A, B, C, and D—but because of the same principle as that in the dyadic relation the final number of fundamental interaction patterns was 12.

(4) Interactional patterns in triadic situations.

In order to analyze the complex triadic structures with certain distinct criteria, interaction among the three persons was represented in a triangle in which father, mother, and the child were respectively placed on each top. The development of an interaction was shown as a chain of such triangles. If there is no action or working upon the other members in the same triadic situation, each member of the triad is connected by a dotted line, implying that they could potentially have interaction with one another (See Fig. 2).

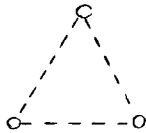

Fig. 2. A Potential Interaction in the Triadic Relation.

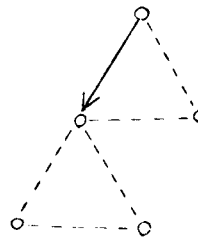

Fig. 3. Partial Interaction in the Triadic Relation.

Each of those dotted lines will be changed to a solid line with an arrow when a member of the triad acts upon either member of the other two and the patient responds to it. At this point, another triangle will again be drawn starting with the patient (See Fig. 3). It is expected that we can determine the nature of each triad's interactional structure after examining how such a structure changes over time in terms of IU analysis and its resultant type comparison.

From the results of preliminary analysis, we set forth the following 6 basic types for the triadic relational structure (See Fig. 4).

Type I : No interaction.

I_A : One member of the triad acts upon another member without getting a response.

I_B : One member of the triad acts upon the other two, but fails to elicit any response.

Type II : Emergence of a dyadic interaction.

II_A : One member of the triad acts upon another member, and the latter accepts it.

II_B : One member of the triad acts upon the other remaining two, and the patients accept it.

Type III : Evident incidence of a triadic interaction.

III_A : There is an evident triadic interaction in that all three members engage in closely related verbal commerce.

III_B : There are two sets of dyadic interaction mediated by one member.

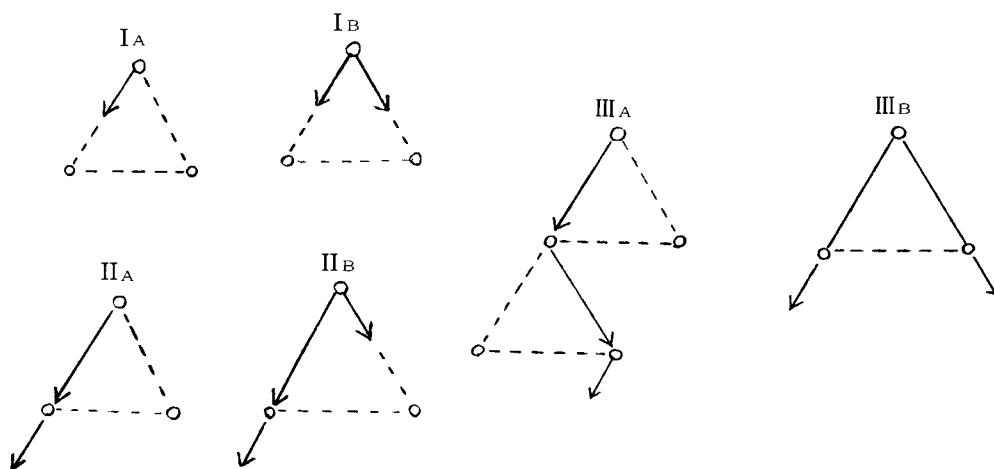

Fig.4. Basic Structures of the Triadic Relation.

The interrelation of IUs could be a complex chain of those basic types, but in such cases the highest basic type in that chain was taken as representing the whole chain.

2. Fundamental viewpoints in the analysis of interactional processes.

(1) Viewpoints in the analysis of dyadic relation.

Each interaction for the dyad of father and child or of mother and child, is not only analyzed into the three levels A, B, and C from its formal aspect in terms of IUs as the basic units, but it is examined as well in terms of its quality with the results of codings for each CU. This analysis was applied to the regular task session and free play session separately in the same dyadic situation.

In addition to the above analysis various indices or scores are derived in order to figure out the characteristics of each dyadic relation, among which are the following : a) "Proportion of initial utterance" (the proportion of which one member of the dyad issued the first verbal action), b) "Evoker rate" (the rate at which the verbal action from one of the dyad succeeded in eliciting the patient's reaction), and c) Content of initial utterances (frequency of initial utterances in terms of the classificatory codes.)

"Proportion of initial utterances" can be regarded as an index of the leading role or dominance in a given dyadic relation, and we could take the "Evoker rate" as an indicator of

the patient's responsiveness or sensitivity to the actor. Finally, "Content of the initial utterances" is literally for the purpose of indexing the quality of initial verbal acting, so that we may understand partially, if not completely, the substantial aspects of the dyadic relation.

(2) Standpoints in the analysis of triadic relation.

As for the triadic interaction setting, the formal aspects of the interactional structure are analyzed into 4 levels (A, B, C, and D) which were described earlier, and in terms of Types I, II, and III as well. Other positions in our analysis are basically the same as in the dyadic condition.

3. Results of the home setting observation.

As stated earlier, our major source data obtained in the home setting are, 1) the tape-recorded verbal commerce among father, mother and child during supper, and 2) the observers' ratings on the triadic structure and on each member's behavior for 2 hours during meal time in the daily home setting.

Thus, the data obtained directly from the home consists of the former records of conversation among father, mother, and child at supper time. The interactional structure is not basically unlike the triadic interrelation in the laboratory setting. Hence, in the analysis of the relational behaviors the analytical procedures for interaction process applied to the home setting were the same as for the laboratory setting, and thus the indices or scores of CUs and IUs were calculated.

Upon the home observation it was noted that several types could be distinguished in parental action (verbal and non-verbal) toward the child. At least 16 cases (11 for the first year and 4 for the second year) on which our analysis was relatively advanced seemed to fall into the following 4 types ;

- 1) Mother dominant : M type.
- 2) Mother leads : M-F type.
- 3) Father leads : F-M type.
- 4) Father dominant : F type.

(1) Proportion of each family member's verbalization at supper.

As the first step of examination, we tried to analyze from several aspects 6 cases which were chosen at random from both extremes of M type and F type (3 cases each), and to elucidate the characteristics of each type.

Results of the analysis are seen in Table 1.

Table 1. Proportion of Verbalization at Supper for Each Member of the Family
(Comparison in the Number of CUs)

Type	Mem-ber Case	M	F	C	S	Total
M	W	36	2	42	2	82
	H	64	5	69	9	148
	K	74	7	88	6	175
F	G	23	60	63	0	146
	N	7	51	40	0	100
	A	50	32	56	2	137

In Table 1, M, F, C, and S denote mother, father, child (the target child), and sibling, respectively.

Here it should be noted that all 3 children for F type were the first born, whereas 2 of the 3 children for M type were the youngest member in their respective families.

Just for a simple comparison we calculated mean proportion for each member from the figures in Table 1 with the dichotomy of M and F type. The results are shown in Fig. 5.

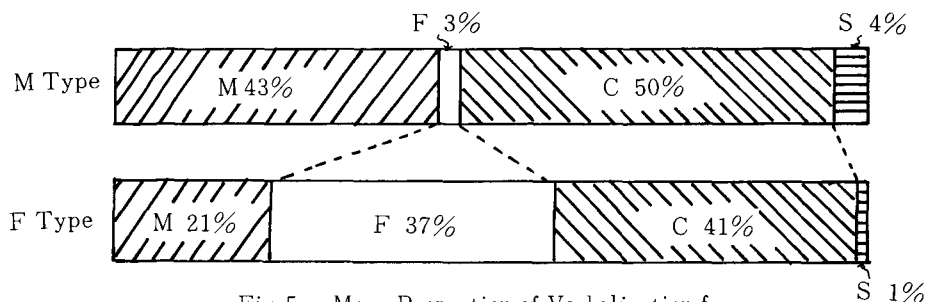

Fig. 5. Mean Proportion of Verbalization for Each Family Member in M and F Type.

These results indicate that in M type, as might be expected from the name, the father's verbalization is negligible, whereas the mother plays a very important role in the parent-child interaction. On the other hand, in F type the father's verbalization amounts to over 10 times of that of the father in M type, whereas the mother's verbalization decreases to one half that of mother in the M type.

(2) Comparison between M and F type in terms of the contents of parental verbalization.

Although there may be many factors which determine parents-child interaction during the meal, one of those must be the contents of parental verbalization (topics). The topic of food or meal is regarded as a direct factor of the parent-child verbal interaction, but the fact that father, mother, and child are all having meal at that time must be operating as a situational or background determinant of the interaction. Thus, classificatory analyses of IUs in the triadic relation in terms of the topics were thought to be helpful in determining the characteristic nature of each type. We classified the topics roughly into two categories, the "food-related" and the "non-food-related", and compared M with F Type against this dichotomy. The result is shown in Fig. 6.

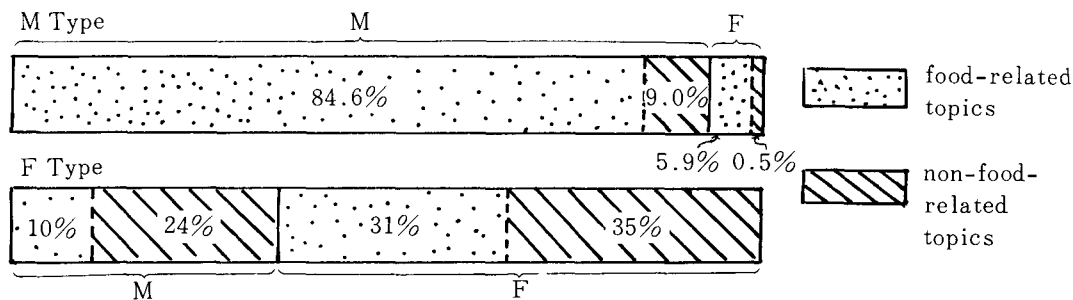

Fig. 6. Comparison between M Type and F Type in Terms of Topics.

As seen in Fig. 6, in M type the conversation with the child is mostly carried by the mother and more than 90% of its content are concerned with food itself. By contrast, in F

type the major partner in conversation with the child is of course the father and more than 50% of his verbal action is concerned with things other than food or meal. In addition, it should be noted that more than 70% of the content of the mother's verbal intervention in F type is also concerned with non-food topics.

The change proportion in topics (CPT) was computed by the following formula and the results are summarized in Table 2.

$$CPT = \left\{ \frac{(\text{number of changes in topics} + 1) \times (\text{classes of topics})}{(\text{total number of IUs})^2} \right\} \times 100$$

Table 2. Change Proportion of Topics.

Type \ case No.	1	2	3	Mean
M	4.62	6.51	6.25	5.79
F	16.25	38.25	29.09	27.99

It is evident that topics in the F type are richer than those in the M type.

(3) Analysis of initial utterances and sub-IUs.

Shown in Fig. 7 are the results of the analyses as to the instigator of conversation in each type of family in terms of IU levels. Fig. 8 shows the classification of sub-IUs from the viewpoint of contributors to the facilitation or expansion of the conversation.

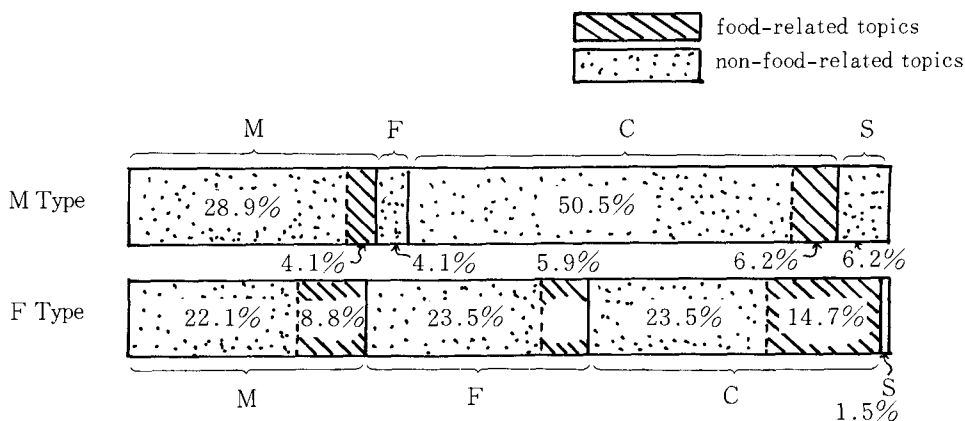

Fig. 7. Proportion of Initial Utterances in Terms of IUs.

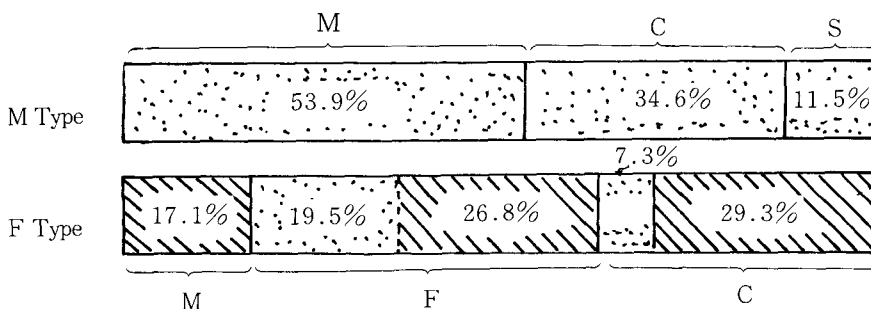

Fig. 8. Contributor to the Development of Conversation in Terms of Sub-IUs.

Tendencies appeared in Fig. 7 and 8 may be summarized as follows ;

In the M type, verbal interaction is often initiated by the child's utterances concerning food, but the mother takes a critical role in developing their conversation, whereas the father holds almost no part in it.

By contrast, in F type the number of initial utterances is in general the same for father and mother, but it is the father who maintains the key role in developing their verbal interaction. As mentioned above, the fact that all the topics which F type mothers take up in the progress of conversation are about the non-food-related does make a sharp contrast to M type mothers.

We examined, in addition, the number of sub-IUs included in each IU for both types (See Table 3).

Table 3. Number of Sub-IUs in an IU.

Type \ No. of Sub.IU	2	3	4	5	6~
M	18	4	0	0	0
F	8	4	0	2	2

It is suggested in Table 3 that verbal commerce in the M type is rather short and intermittent, whereas conversation in the F type is often continuous.

(4) Comparison of the interactional structure.

As might well be expected from the above discussion, there are possibly some substantial differences between M type and F type in terms of the father-mother-child interrelation structure. Thus, as a summation of the analysis thus far, we tried a comparison between M type and F type in terms of interactional structure noted earlier. The resultant figures of this analysis are seen in Table 4.

Table 4. Proportion of Each Interactional Structure (%).

Type \	Type I	Type II	Type III
M	12	75	13
F	17	59	24

Although the percentage of Type II is largest for both M type and F type, the fact that the number of Type III in F type is almost double that of Type III for M type can be taken as plain evidence of the developing nature of the triadic relation in F type.

4. Some results of the questionnaire and interview with parents.

Since the overall examination of data obtained by questionnaire and interview is now in progress, only partial results will be discussed below. Among the items in Questionnaire

(B), several of the most pertinent to our present purpose were chosen in order to compare the results of the "Japan-U.S. Joint Study" and those of our present study. Parental attitudes towards several items of the questionnaire are seen in Fig. 9 to 14. It should be pointed out that the general tendencies are quite similar for both samples. The fact that despite the small number of subjects in our own study there appeared such a high correspondence between the two cultures may imply that the attitudinal tendency in those areas is highly universal.

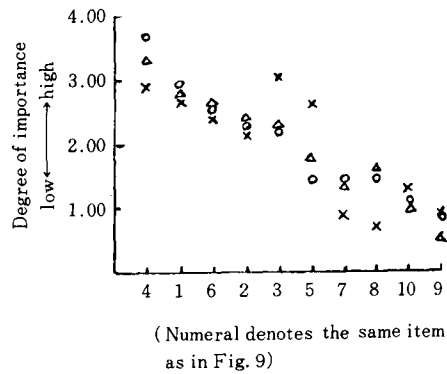
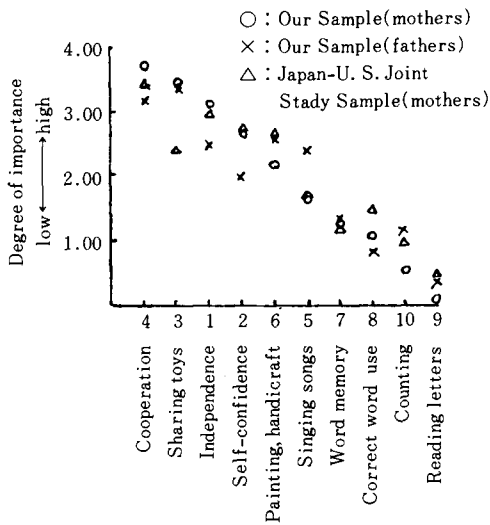

Fig. 10. Relative Importance of Mastery in Kindergarten Education.

Fig. 9. Relative Importance of Mastery in Pre-kindergarten Education.

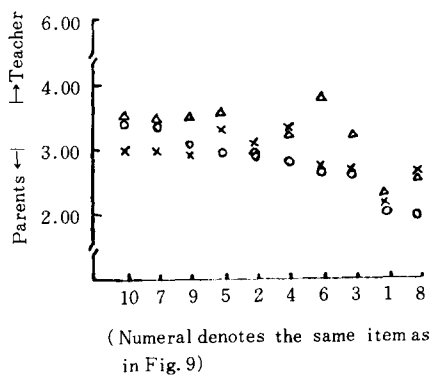

Fig. 11. Responsibility of Teaching.

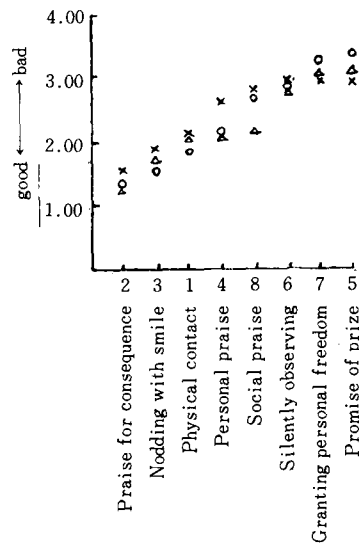

Fig. 12. Preferred Method of Reward.

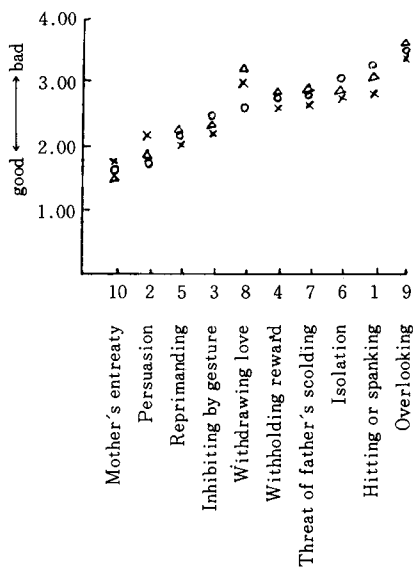

Fig. 13. Preferred Method of Punishment.

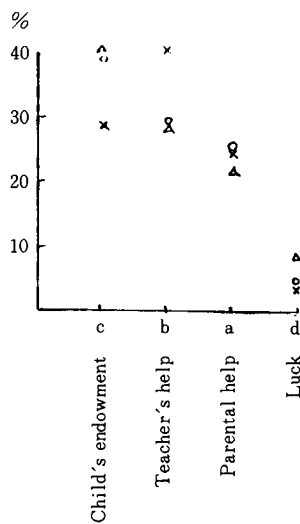

Fig. 14. Contributing Factors in Academic Achievement.

IV. Problems for Future Study.

In this brief report we have described some basic questions which were posed at the onset of this project in connection with the tendency in previous studies on parent-child relationship. We have also outlined our methods and basic standpoints for data analysis. Results are also included to some extent, but they are indeed partial and preliminary and should be subjected to further examination in later analyses.

In process of this research we met with various difficulties. Among others, the most urgent problem was and still is that we have had no established methodology to the dynamic reality of the parent-child interaction. There is no standard by which we can decide how we should provide settings in order to attack the substantial aspects of interaction and what we must use as tasks for the interacting subjects. In a sense we are just groping our way to the most absorbing but intricate jungle of father-mother-child interrelation. Under the circumstances the reader may find various defects and inadequacies in this voucher. It is hoped that those problems will gradually be overcome in our subsequent works.

Thus, although many tasks are left before us, one of our major jobs is that when all the data from the total 25 cases are obtained along the initially prospected schedule we are going to reveal the uniqueness of our sample and the underlying generality with other samples by comparing our results with other relevant studies and by some metric processing. Our second job is more important, according to the original purpose. It is to make a case study approach to our subjects in order to get more vivid and valid understanding of each child by the efficient use of the multivariate data collected.

REFERENCES

- Barker, R.G. *Ecological Psychology*. Stanford University Press, 1968.
- Bee, H.L., et al. "Social Class Differences in Maternal Teaching Strategies and Speech Patterns." *Developmental Psychology*, 1969, 1, 726-734.
- Karnes, M.B., et al. "Education Intervention at Home by Mother of Disadvantaged Infants," *Child Development*, 1970, 41, 925-935.
- Lamb, M.E. (ed.) *The Role of the Father in Child Development*. Wiley, 1976.
- Miyake, K., Wakai, K., Itoh, N., Gotoh, M., and Usui, H. "A Methodological Examination of Developmental Research in Infants and Children : I ," *Bulletin of the Faculty of Education*, Hokkaido University, 1972, 105-141.
- Miyake, K. et al. "A Methodological Examination of Developmental Research in Infants and Children : II," *Bulletin of the Faculty of Education*, Hokkaido University, 1974, 23, 1-66.
- Radin, N. "Father-Child Interaction and the Intellectual Functioning of Four-Year-Old Boys," *Developmental Psychology*, 1972, 6, 353-361.
- Saxe, R.M. and Stollak, G.E. "Curiosity and the Parent-Child Relationship." *Child Development*, 1971, 42, 373-384.

Appendix A : Behavior Rating Scales for Home Observation.

Scale A : Items for Parental Behavior Rating.

1. Whether or not mother (M) or father (F) encourages child toward self-help behavior.
2. Whether or not M or F lets child share or help with house-keeping.
3. Whether or not M or F tries to structure settings in order to facilitate child's activity.
4. Whether or not M or F tries to communicate to child in a proper way.
5. Whether or not M or F's verbal interaction with child is abundant.
6. Whether or not M or F often attempts further interaction with child.
7. Whether or not M or F complements or corrects inadequacy of child's verbal expression.
8. Whether or not M or F pays close attention to child's ability, motivation, and interest.
9. Whether or not M or F controls child's TV-viewing.
10. Whether or not M or F imposes strict restraints on child.
11. Whether or not M or F imposes on the child a strict bed-time schedule.
12. Whether or not M or F often gives directions to child.
13. Whether or not M or F limits or controls child's activity.
14. Whether or not M or F can relax in the observers' presence.
15. Whether or not M or F maintains unyielding attitude toward child.
16. Whether or not M or F often praises child for minimal accomplishments.
17. Whether or not M or F's attachment to child is strongly affected by child's attitude and responses.
18. Whether or not M or F manages to make child obey directions.
19. Whether or not M or F is inclined to subject child to verbal control.

Scale B : Items for Parental Relationship.

1. Whether or not the parents are in a harmonious and matching relationship.
2. Who instigates interaction with child and holds the decisive power for it?.
3. Whether or not the parents experience many disagreements and conflicts in child discipline.

Scale C : Items for Child's Behavior Rating.

1. Whether or not the child's attention span is long.
2. Whether or not the child has a high degree of curiosity, often questioning, and exploring.
3. Whether or not the child initiates verbal interaction with parents.
4. Whether or not the child begins action after deep thought.
5. Whether or not the child is self-reliant, seldom asking parental help.
6. Whether or not the child is self-sustaining, tending to think or play alone.
7. Whether or not the child boasts or shows off his or her achievements.
8. Whether or not the child is responsive to father's action.
9. Whether or not the child is responsive to mother's action.