



Title	Hygroscopic properties of levoglucosan and related organic compounds characteristic to biomass burning aerosol particles
Author(s)	Mochida, Michihiro; Kawamura, Kimitaka
Citation	Journal of Geophysical Research, 109, D21202 https://doi.org/10.1029/2004JD004962
Issue Date	2004-11-06
Doc URL	https://hdl.handle.net/2115/26154
Rights	An edited version of this paper was published by AGU. Copyright 2004, American Geophysical Union, JOURNAL OF GEOPHYSICAL RESEARCH-ATMOSPHERES, 109.
Type	journal article
File Information	JGRA109.pdf



**Hygroscopic properties of levoglucosan and related organic compounds characteristic to
biomass burning aerosol particles**

Michihiro Mochida* and Kimitaka Kawamura

Institute of Low Temperature Science, Hokkaido University, Sapporo, Japan

* Corresponding author

e-mail: mochida@pop.lowtem.hokudai.ac.jp

Submitted to Journal of Geophysical Research – Atmospheres (April 28, 2004)

Abstract

Biomass burning is a significant source of atmospheric organic aerosols, which is characterized by pyrolysis as well as vaporization and condensation of biomass constituents. In this study, hygroscopic properties of five organic compounds (levoglucosan, *D*-glucose, and vanillic-, syringic-, and 4-hydroxybenzoic acids), which are major pyrolysis products of wood, were measured using a tandem differential mobility analyzer. Levoglucosan, which is the most abundant species in wood burning aerosol, showed a significant hygroscopic growth for particles with 100 nm diameter. No efflorescence was observed under the measured relative humidity, and a supersaturated condition of levoglucosan-water particles was observed. The growth factors of levoglucosan are 1.18, 1.23 and 1.38 at relative humidity (RH) of 80, 85 and 90 %, respectively. The measured hygroscopic curves were confirmed to be consistent with those estimated from ideal solution theory, and UNIFAC and COSMO-RS methods. Significant hygroscopic growth was also observed for *D*-glucose, whose growth factor is quite similar to that of levoglucosan. On the other hand, three model pyrolysis products of lignin, *i.e.* vanillic-, syringic-, and 4-hydroxybenzoic acids, did not show any hygroscopic growth under the RH condition up to 95 %. Based on the organic composition of wood burning aerosols, the water absorption due to levoglucosan in wood burning aerosols is calculated to be up to 30 % of the organic mass at 90 % RH. This study demonstrates that oxygenated organics emitted from biomass burning could significantly enhance the hygroscopic properties of atmospheric aerosols.

1. Introduction

Hygroscopic properties of aerosol particles can directly control the size distribution, chemical reactivity and the lifetime. Furthermore, uptake of water vapor by aerosols enhances the light scattering. These properties are tightly linked to radiative balance on the earth as well as air quality. So far, hygroscopic properties of inorganic salts relevant to atmospheric aerosol are evaluated by a number of laboratory studies [*e.g.*, *Tang*, 1997], but little is known about such properties of organics and organic/inorganic mixtures. Recently, *Dick et al.*, [2000] discussed the role of organics in controlling the aerosol hygroscopicity based on the ambient measurement, suggesting that the organic-associated water content of atmospheric aerosols is comparable or greater than that of sulfate at low relative humidity (RH). To date, measurements of hygroscopic properties for organic compounds and organic/inorganic mixture are mainly for low molecular-weight dicarboxylic acids [*Cruz and Pandis*, 2000; *Peng et al.*, 2001a; *Prenni et al.*, 2001], which is known as secondary oxidation products in the atmosphere.

Biomass burning is one of the major sources for organic particulate matter in the atmosphere. The biomass burning smoke enriched with hygroscopic organic constituents is suggested to act as efficient cloud condensation nuclei [*Novakov and Corrigan*, 1996]. The organic composition of biomass burning aerosol is studied on the fields [*e.g.*, *Gao et al.*, 2003] as well as in controlled environment [*Schauer et al.*, 2001; *Fine et al.*, 2002]. It has been revealed that the organic composition of biomass burning aerosol is characterized by several particular oxygenated compounds. Among the compounds derived from combustion of cellulose and hemi-cellulose in biomass, levoglucosan (1,6-anhydro- β -D-glucose) and other anhydrosaccharides are known as major pyrolysis products [*Simoneit et al.*, 1999]. The fraction of levoglucosan in biomass burning organic aerosol particles reaches up to 30% [*Schauer et al.*, 2001]. Furthermore, a number of compounds have been identified as pyrolysis

products of lignins that are also major constituents in plants. Meanwhile, lignin pyrolysis products retain common chemical structures of lignin moiety, such as syringyl ($-C_6H_3(OCH_3)_2OH$), guaiacyl ($-C_6H_4(OCH_3)OH$), and hydroxybenzyl ($-C_6H_5OH$) groups.

Considering the unique chemical constituents of biomass burning aerosols, it is important to know how such unique composition affect the physical-, chemical- and optical properties of aerosol particles. In this study, hygroscopic properties of model organic compounds (levoglucosan, *D*-glucose, and vanillic-, syringic-, and 4-hydroxybenzoic acids) characteristic to biomass burning aerosols were measured using a tandem differential mobility analyzer (TDMA) system. This study mainly focuses on oxygenated organic compounds that are primarily emitted by biomass burning. Here we also discuss an atmospheric chemical implication of the hygroscopic properties of these biomass-burning products.

2. Experimental method for the hygroscopicity measurement of organics

The schematic of the experimental system is presented in Figure 1. Aerosol particles are produced using a pressurized-type atomizer that is connected to a syringe pump containing water solution of organic compounds (ca. 0.1 wt %). The generated aerosol passes through two diffusion dryers in series, where relative humidity of air is reduced to be < 4 %. The dried aerosol particle is introduced to a TDMA system, which consists of Am-241 neutralizer, two differential mobility analyzers (TSI model 3081), aerosol humidity conditioner, and a condensation particle counter (CPC, TSI model 3085). Particles with diameter of 100 nm at < 4 % RH are classified by the DMA1, and the RH for the particles is controlled by an aerosol humidity conditioner. Optionally, the classified particles pass through a humidifier so that the air is saturated with the water vapor, and then the particles are introduced to the aerosol humidity conditioner. This option is designed to measure the particle diameter under a decreasing RH condition from 100 %. In this case, saturated condition of water vapor was

confirmed by checking the presence of dews on the window. On the other hand, the measurement of the particle diameter without the optional humidifier is conducted under the controlled increasing RH condition from $<4\%$. The aerosol sample under controlled RH then enters the system of DMA2 + CPC, where size distribution of aerosol particles is measured. The water vapor was added to the sheath air of DMA2, in which RH is controlled to be nearly equal to the RH of the aerosol sample. The RH in DMA2 is monitored at the DMA inlets of sample air, sheath air, and also the outlet of the sheath air, so as to confirm the RH inside the DMA2 tube to be uniform. All the TDMA experiments were conducted at the sample aerosol temperature of 273-275 K.

In this experiments, particles within a narrow electrical mobility band with a modal diameter of 100 nm were flowed out of DMA1. The size distribution measured by DMA2 + CPC also have a narrow single band with a specific width, which is originated from the classification band width of DMA1 described above as well as the that of DMA2. In this study, modal diameters of the band obtained by DMA2 + CPC were subjected to the calculation of the particle change. Fitting of the measured size distributions with Gaussian curves derived the modal diameters. The measurement errors of the modal diameters were estimated by classifying 100 nm dry particles in DMA1 and then measuring the deviations of the modal diameters using DMA2 + CPC at dry condition. Since both DMA1 and DMA2 are calibrated in the same manner, the deviations may represent errors in diameter measurement originating from DMA. Intra-day deviations of the modal diameters were about 1 %, and were regarded to be errors in diameter in this study.

The particle diameter measured at elevated RH relative to that at $< 4\%$ is presented as hygroscopic growth factor (HGF) in this study. Supersaturated conditions at very dried condition are reported for both inorganics [*Han et al.*, 2002] and organics [*Peng et al.*, 2001b]. Hence, the $RH < 4\%$ does not warrant that the particles are completely dried and present as a

solid. The performance of the TDMA system used in this study were evaluated by measuring growth factor of $(\text{NH}_4)_2\text{SO}_4$ and by comparing it with the modeled HGF estimated from the water activity data of the $(\text{NH}_4)_2\text{SO}_4$ solution in the literature [Tang *et al.*, 1997]. A slight difference between RH and water activity due to Kelvin effect (about 1 %) is taking into account for the HGF estimate, and then the measured and modeled HGFs showed an good agreement within 0.03 at 80 and 85 % RH, and within 0.08 at 90 % RH.

The bulk properties of deliquescence relative humidity (DRH) of organic compounds are measured differently. About 1 ml of saturated water solution of organics is placed in a sealed aluminum dish, and a RH meter (Vaisala TMP 237) was placed above the saturated solution inside the dish. The RH was monitored over 24 hours at 20 °C to measure DRH point. This equipment was also used for the calibration of RH meters used in the TDMA system. The water vapor pressures above the saturated LiCl, NaCl, and K_2SO_4 , solutions were measured using the RH meters and the readings were adjusted and/or checked to the literature values. Under such calibration conditions, the error of the RH measurement is within 2 % due to the manufacturer's warrant.

3. Model organic compounds of the biomass burning aerosol particles

Table 1 compiles organic composition of wood burning aerosol (PM_{2.5}) from Schauer *et al.* [2001]. As shown in the table, levoglucosan, a major pyrolysis products of cellulose and hemi-cellulose, contribute substantially (16-30%) to the total organics in PM_{2.5}. Substituted guaiacols, syringols and phenols, all of which are pyrolysis products of lignins, comprise about 8.5-15.3 % of organics in PM_{2.5}. The rest of identified compounds are relatively minor and many of them, such as polycyclic aromatic hydrocarbons (PAHs) and UCM (highly branched and cyclic alkanes) are insoluble in water and are not likely to contribute to the particle growth. n-Alkanoic, n-alkenoic, and resin acids are not likely to contribute to the

hygroscopic growth either, due to the presence of long chain hydrophobic alkyl groups.

Andrews and Larson [1993] reported that particles composed of the similar structure, sodium dodecyl sulfate, did not show any significant hygroscopic growth up to 90% RH. However, it should be noted that coatings of particles by such surfactants are suggested to slightly enhance the water uptake [*Andrews and Larson*, 1993].

As model compounds for biomass burning aerosols, the following water-soluble organic compounds are subjected to the hygroscopicity experiment in this study: levoglucosan, syringic acid (as substituted syringols), vanillic acid (as substituted guaiacols), and 4-hydroxybenzoic acid (as substituted phenols). Further, *D*-glucose, a hydrolysis product of levoglucosan, was also examined for hygroscopic properties. Although hydrated sugars are not reported by *Schauer et al.* [2001] as not listed in Table 1, various hydrated mono- and disaccharides such as *D*-glucose are also detected in biomass burning aerosols [*Nolte et al.*, 2001]. The chemical structures of organic compounds studied are presented in Figure 2. In the case of experiment using levoglucosan, absence of hydrolysis in the levoglucosan-water mixture prepared for HGF and DRH measurements was confirmed by analyzing the levoglucosan in the solution using GC-MS [*Mochida et al.*, 2003].

4. Results and Discussion

4.1 Growth factors of levoglucosan

In Figure 3, the measured hygroscopic growth factor of levoglucosan for 100 nm dry particles is plotted against RH. As seen in the figure, the growth factor of levoglucosan particles increases as the RH increases. The growth factor changes do not depend on the history of RH, i.e. whether the RH setting was achieved by increasing from < 4 % (open circles) or by decreasing from 100% (solid triangles). The agreement of HGFs between two experiments also warrants that under the controlled moisture condition the growing/shrinking

particles that uptake water are in equilibrium with the surrounding water vapor. The HGFs of levoglucosan at 80, 85 and 90 % RH are 1.18, 1.23 and 1.38, respectively. These values are lower than that for $(\text{NH}_4)_2\text{SO}_4$ (1.45, 1.56 and 1.77 at 80, 85 and 90 % RH, respectively), but higher than some organics such as fulvic acids [*Chan and Chan, 2003*]. No stepwise increase in the growth factor, which can typically be seen for inorganic compounds at the DRH, was not observed for levoglucosan.

The DRH of levoglucosan at 20 °C was obtained to be 80 % by the bulk solution method that is described in the experimental section. The growth of levoglucosan particles below its DRH (80 % RH) as shown in Figure 3 suggests the presence of meta-stable supersaturated condition of the levoglucosan-water mixture. Since the supersaturated condition can be seen by increasing RH from $\text{RH} < 4\%$, the particle at $\text{RH} < 4\%$ may also be supersaturated and not be in the form of dried solid. Such large discrepancies between efflorescence relative humidity and DRH are often reported for both organic and inorganic species. Although the actual dry diameter of levoglucosan is smaller than that at RH 4%, the very low relative humidity (4% RH) suggests that the fraction of water in the mixture is minor. Hence, we regard that the growth factor measured in this study is nearly identical to that from completely dried particle.

In order to evaluate the obtained HGF from the thermodynamic point of view, the HGF of levoglucosan was estimated theoretically by several models. First, the growth curve of levoglucosan was estimated applying the theory for ideal solution. The estimated curve is presented as solid line in Figure 3. Assuming the ideal solution (and also ideal gas) condition, the vapor pressure of water that is in equilibrium with the mixed solution is proportional to the molar ratio of water in the mixed solution. Since the growth factor measurement using the TDMA is on volume basis, the hygroscopic growth factor G was calculated from the molar ratios by the equation:

$$G = \left\{ \frac{(x_W m_W / \rho_W) + (x_L m_L / \rho_L)}{(x_L m_L / \rho_L)} \right\}^{1/3}, \quad x_W + x_L = 1 \quad (1)$$

Where x , m , and ρ mean molar ratio, molecular weight, and density, respectively.

Meanwhile, the subscripts W and L represent water and levoglucosan, respectively. This equation is reliable if the partial molar volumes of organics and water are not largely different from pure compounds.

Furthermore, two vapor-liquid equilibrium (VLE) calculations based on the UNIFAC group contribution method [*Hansen et al.*, 1991] and the quantum-physical calculation method, COSMO-RS [*Eckert and Klamt*, 2002, 2003], were also applied for the estimate of growth curve. The results are superimposed on Figure 3. UNIFAC group contribution method is widely used to predict the activities in mixed organic solution, and it is used for the estimate of the water activities of aqueous organic solution [*Saxena and Hildemann*, 1997]. COSMO-RS method is relatively new approach for the estimate of VLE, and has advantage to be able to treat isomers. The relation between molar ratio and water activity ($\cong \text{RH}/100$) was estimated using the VLE calculations, and the HGF was calculated based on the assumption in equation 1. As shown in the figure, the measured growth curve is within the deviation of the estimated curves from the different three approaches. The ideal solution theory, although it is the simplest, seems to reproduce the measured HGF curves even better than the other two approaches. The fair agreements between measured and predicted HGFs support the reality of the high hydrophilicity of levoglucosan observed in this study.

4.2 Growth factors of D-glucose

The measured growth factors of *D*-glucose are plotted in Figure 4 as a function of RH.

D-glucose also showed deliquescence behavior in the measured RH range. No significant difference was found in the curves of HGFs between two different RH systems; increasing RH (open circles) and decreasing RH (solid triangles). The DRH of *D*-glucose at 20 °C was obtained to be 90 % by the bulk solution method, hence the *D*-glucose particles are present as supersaturated droplets below 90% RH. The growth factor at 80, 85 and 90 % RH are 1.18, 1.24, and 1.37, respectively, being quite similar to those of levoglucosan. In the case of *D*-glucose, hygroscopic growth has been measured previously by an electrodynamic balance (EDB) experiment [Peng *et al.*, 2001] as a function of RH. The EDB experiment measures change in particle masses, whereas HDMA measures that in particle sizes. By assuming the size change from mass change based on the theory in equation 1, the growth factor of *D*-glucose was calculated from the EDB data. The obtained HGFs from EDB data are 1.17, 1.23, 1.39 at 80, 85, and 90 % RH, which are very close to the values we obtained in this study.

The growth curves of *D*-glucose estimated by ideal solution theory, UNIFAC, and COSMO-RS were also shown in Figure 4. In the case of COSMO-RS calculation, The *D*-glucose water solution was simply assumed to be composed of the mixture of α - and β -*D*-glucose. As in the case of levoglucosan, ideal solution theory gives a reasonable prediction for the HGFs of *D*-glucose in the RH range measured in this study. This means that the activity coefficient of water in the particle is not largely different from unity, as far as the assumption presented in equation 1 is true.

4.3 Growth factors of lignin pyrolysis products

In contrast to levoglucosan and *D*-glucose, three model compounds of lignin products, 4-hydroxybenzoic acids (Figure 5) and vanillic and syringic acids (growth curves not shown), did not show any significant particle growth at 100-nm particle diameter under the RH

conditions up to 95 %. Apparently, the characteristic of particle change is different from those estimated by three model approaches, as shown in Figure 5. Instead of the particle growth, a slight decrease in particle diameter was observed at elevated RH condition. The reason for this is not clear, but a similar behavior was reported by *Gysel et al.* [2002] for NaCl-water system. They attributed the decrease in particle diameter at elevated RH to the restructuring of particle shapes that affect the mobility diameter, and the same explanation may apply for this case.

In the case of increasing RH, the absence of particle growth is consistent with the fact that the DRHs of syringic, vanillic and 4-hydroxybenzoic acids measured in this study by the bulk method exceeds 97 % (upper limit to measure reliably for the RH meter). On the other hand, in the case of decreasing RH from saturated condition of water vapor, the absence of particle growth may be due to either one of the following two possibilities. The first case is that the particles deliquesced at the humidifier under the saturated water vapor condition and then effloresced again at $RH > 95\%$. The second case is that the particle did not deliquesced in the humidifier in the limited residence time (about 1 minute).

In order to further seek the possible presence of supersaturated condition of lignin pyrolysis products, a different type of experiment was conducted for 4-hydroxybenzoic acid. First, a pressurized carrier gas entering the atomizer to nebulize the organic-water solution was humidified so that the water content in the carrier gas corresponds to about 80 % RH at 1 atm. The RH of aerosol samples increases to about 90% due to the water evaporation from mist and the aerosol was directly introduced to DMA1 without passing through the aerosol dryer. Particles with 100 nm diameter was selected, followed by dryness to 10 % RH in the aerosol humidity conditioner, and then the resulting size distributions were measured by DMA2 + CPC. In this experiment, particles passing through DMA1 never experienced RH lower than 80 % after they are emitted as deliquesced droplets from the atomizer. No apparent

change in particle diameter was observed between DMA1 and DMA2, while significant “decrease” in diameter was expected in DMA2 in the case that particles were deliquesced in DMA1 (see Figure 5 for the expected differences in diameters at 10 and 90% RH). Hence, it is concluded that supersaturated condition of 4-hydroxybenzoic acid is not likely present under $RH < 80\%$ in our experimental system.

The growth factors of measured organic compounds at 80, 85 and 90 %, as well as the measured DRH are summarized in Table 2. The estimated uncertainties of HGFs are also presented in the table. They are mainly originated from the uncertainty of RH measurements (2 % in RH).

4.4 Atmospheric Implications

It is often suggested that aerosol particles enriched organic compounds becomes more hygroscopic as a result of atmospheric oxidation [*Saxena et al.*, 1995]. On the other hand, this study suggests that particles emitted by the burning of woods and plants already contains large amount of hygroscopic organics, *i.e.* levoglucosan and other relevant anhydro- and hydro-sugars. The mass ratio [particle mass at 80 % RH]/[dry particle mass] of organic fraction in 0.2 μm aerosol particles in Tennessee was assumed to be 1.5 [*Dick et al.*, 2000], whereas the corresponding ratio for levoglucosan is $\{(G^3 - 1)\rho_w + \rho_L\} / \rho_L = 1.40$ at 80 % RH. Hence, levoglucosan have ability to hold water that is nearly comparable to that of the estimated typical water-soluble organic fraction observed in Tennessee. Assuming that levoglucosan comprises 30 % of organic mass (from Table 1), the water content of the particle due to levoglucosan is calculated to be 12, 15 and 30 % of the organic mass at 80, 85 and 90 % RH, respectively. Levoglucosan and other hygroscopic compounds in biomass burning aerosol may not be deliquesced initially because of its high temperature. However, the relatively low DRH of levoglucosan measured in this study suggests that levoglucosan in

biomass burning aerosol can deliquesce at least when the ambient relative humidity is comparable to its DRH. Furthermore, once they deliquesced, they possibly show the supersaturated hygroscopic growth in the real biomass burning aerosols, as is observed in this study.

On the other hand, we did not obtain a clue that lignin pyrolysis products contribute to the growth of aerosol particles. Other identified pyrolysis products of lignin have chemical structures such as -CHO, -R, -R-OH, -R-CHO, -R-COOH instead of -COOH [Nolte *et al.*, 2001]. Hence, considering the less polarity of these functional groups than -COOH, majority of other lignin products may have lower water solubility than -COOH and they are not likely to show particle growth at the RH range in this study. This in turn suggests that formation of more polar organic compounds by the atmospheric oxidation of lignin products have room to increase hygroscopic properties of aerosol particles.

The growth characteristics of real biomass burning aerosols may depend on geometric distribution of compounds in the particle, mixing state in solution with other organic/inorganic constituents, and chemical transformation by oxidation in the air. While *Prezzi et al.* [2003] reported that the growth factor of the mixtures of dicarboxylic acids and ammonium sulfate can be expressed by the sum of water absorption predicted from two pure compounds such like Zdanovskii, Stokes and Robinson (ZSR) approach [Stokes and Robinson, 1966], *Chan and Chan* [2003] suggested deviation from the ZSR explanation for some organic/inorganic mixtures. Furthermore, change in DRH in mixed system as reported by *Andrews and Larson* [1993] is an important factor for hygroscopic properties of atmospheric aerosol particles. If supersaturated condition of organics-water mixture can exist in the real atmosphere, compounds that do not show hygroscopic growth in the single component system (such as lignin products in this study) possibly contribute to the particle growth below its DRH. In this sense, further study on the properties of the mixed aerosol system is necessary

for more quantitative and reliable prediction of the hygroscopic properties of biomass burning aerosols.

5. Conclusions

Five organic compounds (levoglucosan, *D*-glucose, 4-hydroxybenzoic-, vanillic-, and syringic acids), which are uniquely found in biomass burning aerosol particles, have been subjected to the measurements of hygroscopic properties using the tandem differential mobility analyzer system. It has been found that the levoglucosan, as a typical anhydro-sugar in biomass burning aerosols, is substantially hygroscopic under the all RH range measured (<5-95 % RH). Furthermore, *D*-glucose as a typical hydro-sugar, which may be primarily emitted and/or formed secondary by the hydrolysis of unhydrosugar, showed a hygroscopic growth as well. The growth curves of levoglucosan and *D*-glucose were well represented by those estimated from the ideal solution theory of the organic-water mixture. On the other hand, other three water-soluble organic compounds that formed by pyrolysis of lignins (4-hydroxybenzoic-, vanillic-, and syringic acids) did not show any hygroscopic growth up to 95 % RH. The capacity to hold water for levoglucosan was evaluated by taking into account its relative abundance in real biomass burning aerosol particles, and the capacity have found to be substantial even on the total organic mass basis.

For levoglucosan and *D*-glucose, the deliquesced relative humidity was found to be substantially lower than other three organics, and these particles have revealed to grow below their deliquesced relative humidity. The behavior of particle growth down to RH < 4% is similar to those observed for ambient aerosols [Berg *et al.*, 1998]. Hence, they possibly contribute the particle growth in ambient biomass burning aerosols under their deliquesced relative humidity.

This study focused on hygroscopic properties of pure organic compounds characteristic

to biomass burning aerosol particles. In real biomass burning aerosols that is more complex in composition, deviation of water-absorption capacity from those of pure organics cannot be ruled out, due to the solute-solute interactions between different compounds. In addition, change in effloresced behavior in the mixed system possibly alters the contribution of less hygroscopic compounds. Such changes in hygroscopic properties in the mixed system will be the focus of future studies.

Acknowledgements

This work was supported in part by the Ministry of Education, Science, Sports, and Culture through Grants-in-Aid 14204055 and 14658149. We thank Dr. Y. Iinuma for valuable comments on the build up of the TDMA system.

References

- Andrews, E. and S. M. Larson, Effect of surfactant layers on the size changes of aerosol particles as a function of relative humidity, *Environ. Sci. Technol.*, *27*, 857-865, 1993.
- Chan, M. N., and C. K. Chan, Hygroscopic properties of two model humic-like substances and their mixtures with inorganics of atmospheric importance, *Environ. Sci. Technol.*, *37*, 5109-5115, 2003.
- Cruz, C. N., and S. N. Pandis, Deliquescence and hygroscopic growth of mixed inorganic-organic atmospheric aerosol, *Environ. Sci. Technol.*, *34*, 4313-4319, 2000.
- Dick W. D., P. Saxena, and P. H. McMurry, Estimation of water uptake by organic compounds in submicron aerosols measured during the Southeastern Aerosol and Visibility Study, *J. Geophys. Res.*, *105(D1)*, 1471-1479, 2000.
- Eckert, F., and A. Klamt, First Solvent Screening via Quantum Chemistry: COSMO-RS approach, *AIChE Journal*, *48*, 369, 2002.
- Eckert, F., and A. Klamt, *COSMOtherm*, Version C1.2, Release 01.03; COSMOlogic GmbH & Co. KG, Leverkusen, Germany, 2003.
- Fine, P. M., G. R. Cass, and B. R. T. Simoneit, Chemical characterization of fine particle emissions from the fireplace combustion of woods grown in the southern United States, *Environ. Sci. Technol.*, *36*, 1442-1451, 2002.
- Hansen, H.K, P. Rasmussen, A. Fredenslund, M. Schiller and J Gmehling, Unifac model parameters were taken from Vapor Liquid Equilibria by UNIFAC Group Contribution, 5. Revision and Extension, *Ind. Eng. Chem. Res.*, *30*, 2355-2358, 1991.
- Gao, S., D. A. Hegg, P. V. Hobbs, T. W. Kirchstetter, B. I. Magi, and M. Sadilek, Water-soluble organic components in aerosols associated with savanna fires in southern Africa: Identification, evolution, and distribution, *J. Geophys. Res.*, *108(D13)*, 8491, doi:10.1029/2002JD002324, 2003.

- Gysel, M., E. Weingartner, and U. Baltensperger, Hygroscopicity of aerosol particles at low temperatures. 2. Theoretical and experimental hygroscopic properties of laboratory generated aerosols, *Environ. Sci. Technol.*, 36, 63-68, 2002.
- Mochida, M., K. Kawamura, N. Umemoto, M. Kobayashi, S. Matsunaga, H.-J. Lim, B. J. Turpin, T. S. Bates, and B. R. T. Simoneit, Spatial distributions of oxygenated organic compounds (dicarboxylic acids, fatty acids, and levoglucosan) in marine aerosols over the western Pacific and off the coast of East Asia: Continental outflow of organic aerosols during the ACE-Asia campaign, *J. Geophys. Res.* 108(D23) 8638, doi:10.1029/2002JD003249, 2003.
- Nolte, C. G., J. J. Schauer, G. R. Cass, and B. R. T. Simoneit, Highly polar organic compounds present in wood smoke and in the ambient atmosphere, *Environ. Sci. Technol.*, 35, 1912-1919, 2001.
- Novakov, T., and C. E. Corrigan, Cloud condensation nucleus activity of the organic component of biomass smoke particles, *Geophys. Res. Lett.*, 23, 2141-2144, 1996.
- Peng, C., M. N. Chan, and C. K. Chan, The hygroscopic properties of dicarboxylic and multifunctional acids: Measurements and UNIFAC predictions, *Environ. Sci. Technol.*, 35, 4495-4501, 2001a.
- Peng, C., A. H. L. Chow, and C. K. Chan, Hygroscopic study of glucose, citric acid, and sorbitol using an electrodynamic balance: Comparison with UNIFAC predictions, *Aerosol Science and Technology*, 35, 753-758, 2001b.
- Prezzi, A. J., P. J. DeMott, S. M. Kreidenweis, D. E. Sherman, L. M. Russell, and Y. Ming, The effects of low molecular weight dicarboxylic acids on cloud formation, *J. Phys. Chem.*, A105, 11,240-11,248, 2001.
- Prezzi, A. J., P. J. DeMott, and S. M. Kreidenweis, Water uptake of internally mixed particles containing ammonium sulfate and dicarboxylic acids, *Atmos. Environ.*, 37, 4243-4251,

2003.

- Reugg, M., and B. Blanc, The water activity of honey and related sugar solutions, *Lebensm.-Wiss.u.-Technol.* 31, 3318-3324, 1981.
- Saxena, P., L. M. Hildemann, P. H. McMurry, and J. H. Seinfeld, Organics alter hygroscopic behavior of atmospheric particles, *J. Geophys. Res.*, 100, 18,755-18,770, 1995.
- Saxena, P., and L. M. Hildemann, Water absorption by organics: Survey of laboratory evidence and evaluation of UNIFAC for estimating water activity, *Environ. Sci. Technol.*, 31, 3318-3324, 1997.
- Schauer, J. J., M. J. Kleeman, G. R. Cass, and B. R. T. Simoneit, Measurement of emissions from air pollution sources. 3. C1-C29 organic compounds from fireplace combustion of wood, *Environ. Sci. Technol.*, 35, 1716-1728, 2001.
- Simoneit, B. R. T., J. J. Schauer, C. G. Nolte, D. R. Oros, V. O. Elias, M. P. Fraser, W. F. Rogge, and G. R. Cass, Levoglucosan, a tracer for cellulose in biomass burning and atmospheric particles, *Atmos. Environ.*, 33, 173-182, 1999.
- Stokes, R. H., and R. A. Robinson, Interactions in aqueous nonelectrolyte solutions, I, Solute-solvent equilibria, *J. Phys. Chem.*, 70, 2126-2131, 1966.
- Tang, I. N., Thermodynamic and optical properties of mixed-salt aerosols of atmospheric importance, *J. Geophys. Res.*, 102, 1883-1893, 1997.

Author Addresses

Michihiro Mochida and Kimitaka Kawamura, Institute of Low Temperature Science, Hokkaido University, N19 W8, Kita-ku, Sapporo 060-0819, Japan (e-mail: mochida@pop.lowtem.hokudai.ac.jp)

Figure captions

- Figure 1.** Schematic of a tandem differential mobility analyzer (TDMA) system.
- Figure 2.** Chemical structures of five organic compounds studied. *D*-glucose in water solution is mainly in the forms of α - and β - *D*-glucose. The structure of β -*D*-glucose is presented here.
- Figure 3.** Hygroscopic growth factors of levoglucosan as a function of RH. The open circles and solid triangles show the measured hygroscopic growth factors by increasing and decreasing RH, respectively. Initial dry particle diameter is 100 nm. Solid, dotted, and dashed curves are growth factors estimated based on ideal-solution theory, UNIFAC and COSMO-RS, respectively.
- Figure 4.** Hygroscopic growth factors of *D*-glucose as a function of RH. The open circles and solid triangles show the measured hygroscopic growth factors by increasing and decreasing RH, respectively. Initial dry particle diameter is 100 nm. Solid, dotted, and dashed curves are growth factors estimated based on ideal-solution theory, UNIFAC and COSMO-RS, respectively.
- Figure 5.** The growth factors of 4-hydroxybenzoic acid as a function of RH. The open circles and solid triangles show the measured hygroscopic growth factors by increasing and decreasing RH, respectively. Initial particle diameter is 100 nm. Solid, dotted, and dashed curves are growth factors estimated based on ideal-solution theory, UNIFAC and COSMO-RS, respectively.

Table 1 Mass fraction (%) of organic compounds in wood burning aerosols (Data assimilated from *Schauer et al.* [2001]).

	Pine	Oak	Eucalyptus
* Levoglucosan	18.1	16.2	30.2
* Other sugars	5.3	1.7	1.2
* Syringol and substituted syringols	0.0	8.1	7.0
* Guaiacol and substituted guaiacols	6.8	1.2	0.8
* Phenol and substituted phenols	1.7	6.0	1.0
n-Alkanoic, n-alkenoic, and resin acids	6.0	1.7	1.3
UCM and PAHs	10.5	14.2	7.0
Other identified organics	1.1	4.1	2.7
Unextractable and nonelutable organics	50.5	46.7	48.8

The compounds subjected to the hygroscopicity measurement are shown with stars.

Table 2 Deliquescence relative humidity (%) and hygroscopic growth factors for oxygenated organic compounds studied.

	DRH	HGF		
	(%)	80% RH	85% RH	90% RH
Levoglucozan	80 ^a	1.18±0.02	1.23±0.04	1.38±0.07
<i>D</i> -glucose	89.1 ^b 90 ^a	1.18±0.02	1.24±0.04	1.37±0.07
Syringic acid	>97 ^a	≤1.0	≤1.0	≤1.0
Vanillic acid	>97 ^a	≤1.0	≤1.0	≤1.0
4-Hydroxybenzoic acid	>97 ^a	≤1.0	≤1.0	≤1.0

^aThis study. ^b*Reugg and Blanc* [1981].

Fig. 1 Mochida and Kawamura

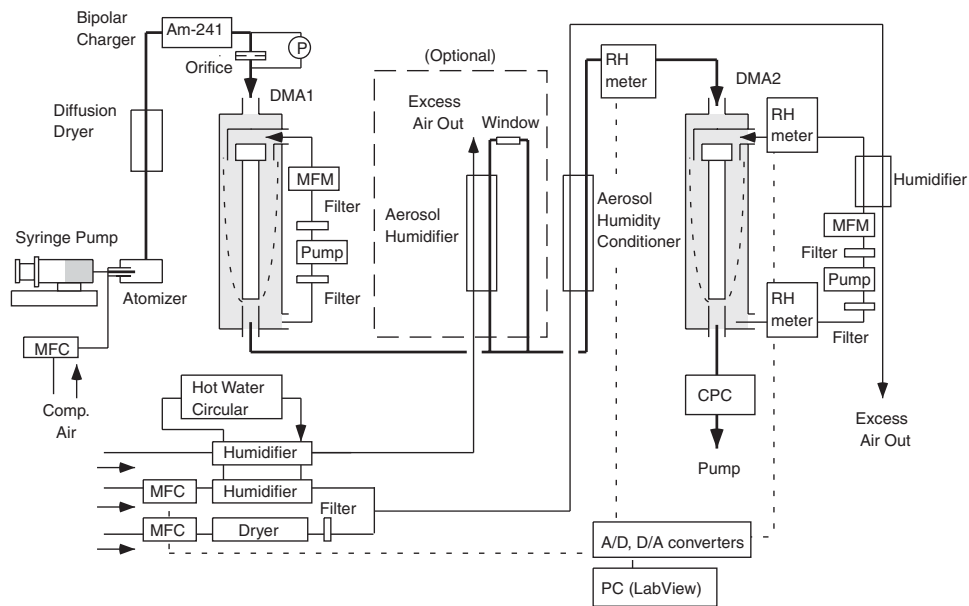
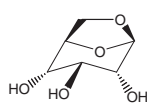
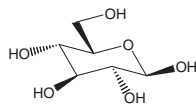

Fig.2 Mochida and Kawamura



levoglucosan



D-glucose

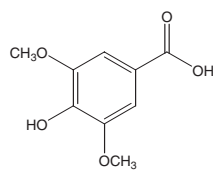

syringic acid

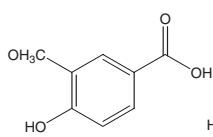

vanillic acid

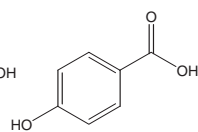

4-hydroxybenzoic acid

Fig.3 Mochida and Kawamura

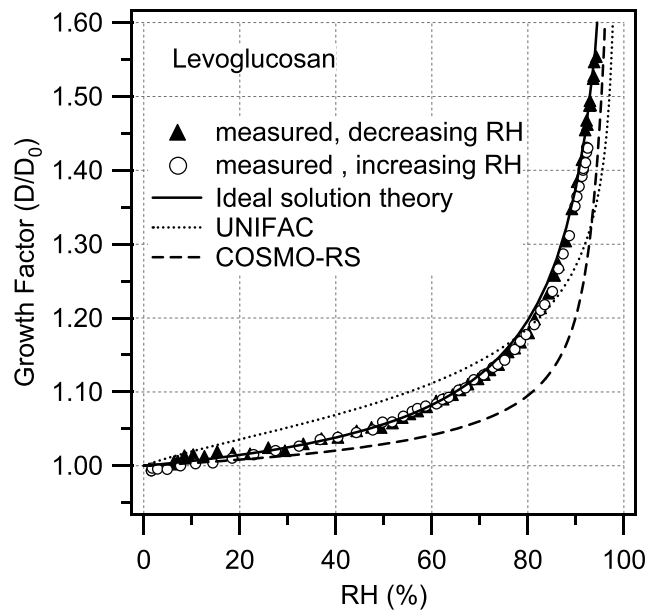

Fig.4 Mochida and Kawamura

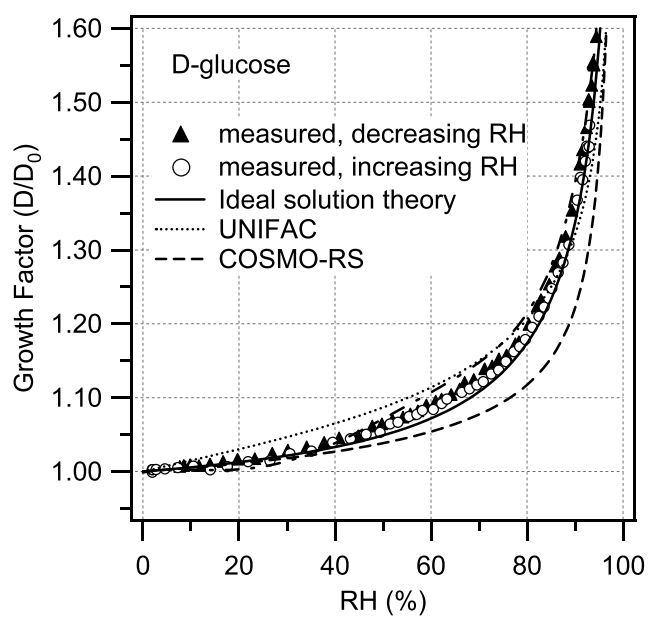

Fig.5 Mochida and Kawamura

